

MB1050

MBOX with
1050 Control Board

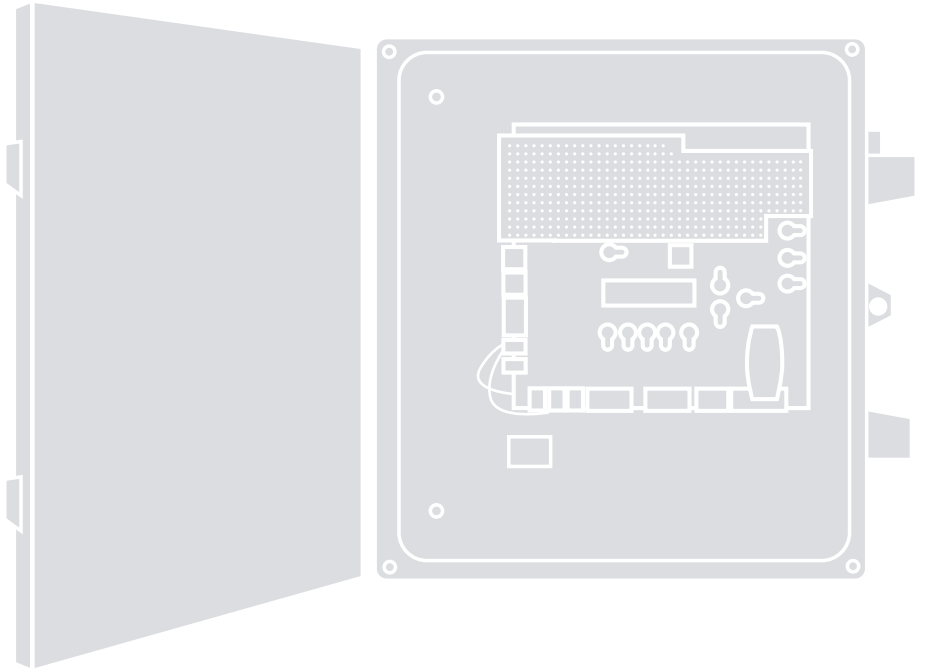

Control enclosure

EN - Installation reference manual

IMPORTANT - Default setting of 24VDC in control board must be changed to 12VDC if using with a Nice residential gate operator.

CONTENTS

1: 1050 CONTROL BOX OVERVIEW	3
1.1 1050 CONTROL BOARD FEATURES	3
2: MB1050 CONTROL BOX PARTS ID... ..	4
3: UL325 USAGE CLASSES & SAFETY.....	5
4: INSTALLATION SAFETY.....	13
5: TOOLS & MATERIALS NEEDED	13
6: MB1050 CONTROL BOX INSTALL.....	14
7: CONTROL BOX POWER WIRING	20
8: PROGRAMMING AND CONTROLS.....	35
9: 1050 ACCESSORY CONNECTIONS.....	53
9.1 OUTPUT CONNECTORS	54
9.2 INPUT CONNECTORS	56
9.3 EMERGENCY VEHICLE ACCESS.....	59
9.4 COMMUNICATIONS BUS.....	60
10: APPENDIX	61
10.1 CALCULATE SOLAR REQUIREMENTS .	61
10.2 MAINTENANCE SCHEDULE	62
10.3 SYSTEM TROUBLESHOOTING	63
10.4 INSTALLATION CHECKLIST.....	64
10.5 PART DRAWINGS.....	65
11: WARRANTY	67

SECTION 1: MB1050 CONTROL BOX OVERVIEW

Congratulations on selecting a Nice Series gate operator using the 1050 control board. With proper selection, system design, installation and maintenance this operator should provide years of reliable operation. This manual covers ONLY the installation of the control box. Refer to appropriate manual for actuator installation.

The MB1050 is used in the following Nice gate operator systems with associated gate actuators:

- 1551 System with 816 LA actuator
- Titan12L1 LA System with 912L actuator
- 3501 System with articulating arm chassis

IMPORTANT!

Anyone who installs, assists with installation or otherwise facilitates the installation in any manner should thoroughly read and understand this manual in its entirety before any attempt is made to actually begin the installation process.



CAUTION

These operators are all 12V operators and the MB1050 is by default a 24V controller. Be sure to turn ON the Motor 12V setting under the FUNCTION BUTTON/Advanced Settings in SECTION 8 prior to operation if powering one of these operators.

1.1 1050 CONTROL BOARD FEATURES

- 2-line LCD with 5 dedicated programming buttons, 3 buttons for navigation, 3 buttons for open, close, and stop.
- A plug-in Nice radio receiver for control by up to 1000 transmitters.
- Connectors include 2-wire Bluebus for self-monitored photocells for entrapment protection.
- Dry contact inputs provided for loop, probe, edge, & photo detectors, guard station, fire dept.
- 1050 control board accepts DC input voltage of 10 VDC to 35 VDC.
- Voltage output (+12V DC and +24 VDC) connectors to power various added accessories.
- Built-in regulator to keep the battery charged (either through Solar or Main DC Power).
- Inputs for batteries, Main DC Power, and solar panel.
- Eight clock/calendar timers for scheduled weekly or daily events (i.e. opening, closing, or locking).
- Programmable gate opening and closing speed, acceleration, soft-start settings, and reverse speed.
- Programmable auto-close, force, speed, opening delay.
- Built-in current sensing for gate force monitoring and limiting with on-board alarm.
- Low power consumption in stand-by mode.
- Built-in voltmeter to check input voltage, battery voltage, solar panel voltage and motor's current.
- Temperature sensor to optimize charging battery and system performance.
- Programmable service alarm.
- Surge suppression on every peripheral input (digital and analog).
- A RJ-11 jack connection for optional O-view programmer and Bluetooth module for PC control.
- Durable, waterproof, and compact enclosure with latches.
- Integral power supply for easy AC hookup.
- Two 8 Ahr 12V batteries built in.
- Dedicated power switch and line fuse.
- Integral audio alarm for signaling gate activity and/or hard shutdown status.

MB1050

Installation and Programming Manual

MB1050 SPECIFICATIONS

Max. Degree Of Opening	Standard install = 105°, Special install = 120°
Solar Compatible	YES
Operating Temperature	-4° to 122° F (-20° to 50° C)
Box Weight	24.6 lbs. (11 kg)
Dimensions (WxHxD)	14-1/2" x 15-3/8" x 7-1/2"
Push-To-Open Installation	YES
Pull-To-Open Installation	YES
Number Of Gates Controlled	Single gate or dual gate
Sensor Type Inputs	Edge, Photo Eye, and Ground Loops
AC Voltage Input	115-230 VAC
DC Voltage Input	Main DC Power In: 10-35 VDC, Solar In: 10-35 VDC, 30A Max.
Power Supply Output	12 to 24 VDC
Battery Power	12 VDC
Included Sensors	Photo Eye TX/RX Through Beam Pair or Alternative Reflective Photo Eye
User Controls	1050 Control Board: Open, Close, Stop, Reset
Accessory Connectors	Power, Mag Lock, Lamp, Alarm, Loops, Edge, Exit, Guard Station, Fire, BlueBUS
Relays	Two programmable relays
UL 325 Certification	Usage Class I, II, III, IV

ACTUATOR SPECIFICATIONS

SPEC TYPE	1551 SYSTEM	TITAN12L SYSTEM	3501 SYSTEM
	816 ACTUATOR	912L ACTUATOR	3500 ARTICULATING ARM
Drive Type	Electromechanical Screw	Electromechanical Screw	Electromechanical Articulated Arm
Open/Close Time	14 - 16 Seconds	14 - 16 Seconds	12 - 20 seconds
Gate Max Length and Weight	16 foot (4.9m) leaf @ up to 600 lb. (272 kg)	<ul style="list-style-type: none"> • 20 foot (6m) leaf @ up to 600 lb. (272 kg) • 8 ft (2.4 m) leaf @ up to 1000 lb (453 kg) 	20 foot (6m) leaf @ up to 1000 lb (272 kg)
Actuator Lengths (from mount hole to mount hole)	41 inches (104 cm) retracted 67 inches (170 cm) extended	43 inches (176.5 cm) retracted 69.5 inches (103.3 cm) extended	Articulating Arm Chassis (WxHxD): 17.8 x 12 x 8.3 inches (45x30.4x21 cm)

SECTION 2: MB1050 CONTROL BOX PARTS IDENTIFICATION

1050 CONTROL BOX PARTS LIST

PART#	DESCRIPTION	QTY
MB1050	Control Box with 1050 Controller	1
OXIBD/A	Multi-Channel Plug-in Receiver	1
ABF/A	Antenna for Multi-Channel Plug-in Receiver	1
273C	Gate Warning Signs (UL Requirement)	2
75500019	Cable Ties (for Warning Signs)	4
911	Audio Alarm (UL Requirement)	1
EPMB/A or EPMORB/A	Photo eye (UL Requirement): Either thru-beam pair (P/N EPMB/A) or reflective photo eye (P/N EPMORB/A).	1



SECTION 3: SAFETY AND UL325 USAGE CLASSES

SAFETY MESSAGES

The safety messages below inform you about potential hazards that can result in injury. Safety messages specifically address level of exposure to operator and are preceded by one of four words: **DANGER**, **WARNING**, **CAUTION** or **NOTICE**.

DANGER

Indicates a hazardous situation which, if not avoided, **WILL** result in **DEATH** or **SERIOUS INJURY**.

WARNING

Indicates a hazardous situation which, if not avoided, **COULD** result in **DEATH** or **SERIOUS INJURY**.

CAUTION





Indicates a hazardous situation which, if not avoided, **COULD** result in **MINOR** or **MODERATE INJURY**.

NOTICE

Addresses practices not related to personal injury. Indicates damage to equipment is probable if the hazardous situation is not avoided.

COMMON INDUSTRIAL SYMBOLS

These international safety symbols may appear on product or in its literature to alert of potential personal injury hazards. Obey all safety messages that follow these symbols to avoid possible injury or death.

Symbol	Safety Hazard
	Attention - Take Notice
	Danger - Keep Away
	Entrapment Zone
	Possible Pinch Point

IMPORTANT SAFETY INSTRUCTIONS

Hazards, associated with automatic gates, can be reduced with proper site design, installation, and use. Installers, maintenance crews, and owners/users must read and follow the safety requirements found in HySecurity® product manuals.



It is important that only qualified installers handle installation of HySecurity Gate vehicular gate operators. A “qualified” installer has one of the following:



1. A minimum of three years experience installing similar equipment.
2. Proof of attending a HySecurity Technical Training seminar within the past three years.
3. Significant manufacturer endorsements of technical aptitude in gate operator installation and operation.

Underwriter Laboratories (UL) and the American Society for Testing and Materials (ASTM) are responsible for current safety standards and regulations regarding gate operators and automated gates. All aspects of gate installation must comply with the appropriate safety standard. For the most up-to-date ASTM F2200 Gate and Fence Standards, refer to www.astm.org. For UL 325 Safety Standard, refer to www.ul.com. Consult local government agencies for up-to-date rules and regulations as certain municipalities have established licensing, codes or regulations that regulate automated gate system design and installation.

GENERAL SAFETY INFORMATION

A gate operator is only a component in a gate system. The other parts of the gate system can include the gate, the external safety sensors, access controls, and vehicle detectors. To have a gate system that provides for safety, security, and reliable operation it is essential these components operate together as a system. It is the responsibility of the system designer and/or installer to ensure any safety or operational issues have been addressed.

WARNING

To reduce the risk of injury or death:

1. READ AND FOLLOW ALL INSTRUCTIONS.
2. Never let children operate or play with gate controls. Keep the remote control away from children.
3. Always keep people and objects away from the gate. **NO ONE SHOULD CROSS THE PATH OF THE MOVING GATE.**
4. Test the gate operator monthly. The gate **MUST** reverse on contact with a rigid object or stop when an object activates the non-contact sensors. After adjusting the force or the limit of travel, retest the gate operator. Failure to adjust and retest the gate operator properly can increase the risk of injury or death.
5. Use the emergency release only when the gate is not moving.
6. **KEEP GATES PROPERLY MAINTAINED.** Read the user's manual. Have a qualified service person make repairs to gate hardware.
7. The entrance is for vehicles only. Pedestrians must use separate entrance.
8. **SAVE THESE INSTRUCTIONS.**

IDENTIFYING GATE OPERATOR CATEGORY AND UL 325 USAGE CLASS

The UL 325 standard covers gate operators. Within this safety standard several Usage Classes are described that define different types of installations where gate operators can be applied. Some operators are restricted in their usage application. Appropriate Usage Classes are shown in the Specifications.

Class I



Class I: Intended for use in a location of one to four single family dwellings or a parking area associated with one to four single family dwellings.

Class II



Class II: Intended for use in a commercial location or building such as a multi-family housing units (five or more single family units) hotels, garages, retail stores or other buildings servicing general public.

Class III

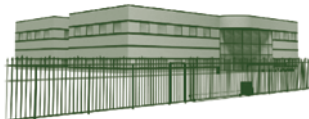

Class III: Intended for use in an industrial location or building such as factories or loading docks or other locations not accessible by the general public.

Class IV



Class IV: Intended for use in guarded industrial locations or buildings such as an airport security area or other restricted access location, not servicing general public, in which access is monitored by security personnel or via closed circuitry.

VEHICULAR TRAFFIC ONLY

WARNING

This automatic gate operator is not designed nor is it intended for pedestrian traffic. Vehicular gate operators must by their nature be powerful to function reliably. This power can cause injury or death. Accordingly, direct all pedestrian traffic to a separate walk-through gate.

Install this gate operator only when:

- The operator is appropriate for the construction of the gate and the usage Class of the gate.
- All openings of a horizontal slide gate are guarded or screened from the bottom of the gate to a minimum of 1.83 m (6 ft) above the ground to prevent a 57.2 mm (2-1/4 in) diameter sphere from passing through the openings anywhere in the gate, and in that portion of the adjacent fence that the gate covers in the open position.
- All exposed pinch points are eliminated or guarded.
- Guarding is supplied for exposed rollers.

The operator is intended for installation only on gates used for vehicles. Pedestrians must be supplied with a separate access opening. The pedestrian access opening shall be designed to promote pedestrian usage. Locate the gate such that persons will not come in contact with the vehicular gate during the entire path of travel of the vehicular gate.

The gate must be installed in a location so that enough clearance is supplied between the gate and adjacent structures when opening and closing to reduce the risk of entrapment. Swinging gates shall not open into public access areas.

The gate must be properly installed and work freely in both directions prior to the installation of the gate operator. Do not over-tighten the operator clutch or pressure relief valve to compensate for an improperly installed, improperly functioning, or damaged gate.

Permanently mounted controls intended for user activation must be located at least 1.83 m (6 ft) away from any moving part of the gate and where the user is prevented from reaching over, under, around or through the gate to operate the controls.

- Exception: Emergency access controls only accessible by authorized personnel (e.g. fire, police, EMS) may be placed at any location in the line-of-sight of the gate.

The Stop and/or Reset button must be located in the line-of-sight of the gate. Activation of the reset control shall not cause the operator to start.

A minimum of two (2) WARNING SIGNS shall be installed, in the area of the gate. Each placard is to be visible by persons located on the side of the gate on which the placard is installed.

For gate operators utilizing a non-contact sensor (Photo Eye):

- See instructions on the placement of non-contact sensors for each type of application.
- Care shall be exercised to reduce the risk of nuisance tripping, such as when a vehicle trips the sensor while the gate is still moving.
- One or more non-contact sensors shall be located where the risk of entrapment or obstruction exists, such as the perimeter reachable by a moving gate or barrier.

For a gate operator utilizing a contact sensor (Edge):

- One or more contact sensors shall be located where the risk of entrapment or obstruction exists, such as at the leading edge, trailing edge, and postmounted both inside and outside of a vehicular horizontal slide gate.
- A hardwired contact sensor shall be located and its wiring arranged so that the communication between the sensor and the gate operator is not subjected to mechanical damage.
- A wireless device such as one that transmits radio frequency (RF) signals to the gate operator for entrapment protection functions shall be located where the transmission of the signals are not obstructed or impeded by building structures, natural landscaping or similar obstruction. A wireless device shall function under the intended end-use conditions.
- One or more contact sensors shall be located on the inside and outside leading edge of a swing gate. Additionally, if the bottom edge of a swing gate is greater than 152 mm (6 in) but less than 406 mm (16 in) above the ground at any point in its arc of travel, one or more contact sensors shall be located on the bottom edge.

USE OF VEHICLE DETECTORS

Use of vehicle detectors (loop detectors) is strongly encouraged to prevent damage to vehicles caused by gates closing on them. This is not considered to be a safety item as vehicle detectors cannot provide protection to pedestrians. In some situations, photoelectric devices may be used as vehicle detectors, but should be wired accordingly.

GATE CONSTRUCTION AND SAFETY

Gate construction plays a very important role in ensuring the safety of any automated gate system. The standard for gate construction is ASTM F2200. Below are key areas to address in gate design for safety. For complete information consult the standard. Copies of the standard are available at:

<https://www.astm.org/Standards/F2200.htm>.

Another source of information is available from DASMA, the Door and Access System Manufacturer's Association. The Association publishes Technical Data Sheets, one of which concerns ASTM F2200. For more information, see:

<http://www.dasma.com/PDF/Publications/TechDataSheets/OperatorElectronics/TDS370.pdf>.

General Requirements for gate construction:

- Gates shall be constructed in accordance with the provisions given for the appropriate gate type listed. Refer to ASTM F2200 for additional gate types.
- Gates shall be designed, constructed and installed to not fall over more than 45 degrees from the vertical plane, when a gate is detached from the supporting hardware.
- Gates shall have smooth bottom edges, with vertical bottom edged protrusions not exceeding 0.50 in (12.7 mm) other than the Exceptions listed ASTM F2200.
- The minimum height for barbed wire shall not be less than 6 ft (1.83 m) above grade. The minimum height for barbed tape shall not be less than 8 ft (2.44 m) above grade.
- An existing gate latch shall be disabled when a manually operated gate is retrofitted with a powered gate operator.
- A gate latch shall not be installed on an automatically operated gate.
- Protrusions shall not be permitted on any gate. Consult ASTM F2200 for exceptions.
- Gates shall be designed, constructed and installed such that their movement shall not be initiated by gravity when an automatic operator is disconnected.
- For pedestrian access in the vicinity of an automated vehicular gate, a separate pedestrian gate shall be provided. The pedestrian gate shall be installed in a location such that a pedestrian shall not come in contact with a moving vehicular access gate. A pedestrian gate shall not be incorporated into an automated vehicular gate panel.
- Any non-automated gate that is to be automated shall be upgraded to conform to the provisions of this specification.
- This specification shall not apply to gates generally used for pedestrian access and to vehicular gates not to be automated.
- Any existing automated gate, when the operator requires replacement, shall be upgraded to conform to the provisions of this specification in effect at that time.

The following provisions shall apply to Class I, Class II, Class III, and Class IV vehicular horizontal swing gates:

Gates shall be designed, constructed and installed so as not to create an entrapment area between the gate and the supporting structure or other fixed object when the gate moves toward the fully open position, subject to the following provisions.

The width of an object (such as a wall, pillar or column) covered by a swing gate when in the open position shall not exceed 4 inches (102 mm), measured from the centerline of the pivot point of the gate. Exception: For a gate that is not in compliance with this provision, the defined area shall be subject to the entrapment protection provisions of UL 325.

Except for the zone specified above the distance between a fixed object such as a wall, pillar or column, and a swing gate when in the open position shall not be less than 16 inches (406 mm). Exception: For a gate that is not in compliance with this provision, the defined area shall be subject to the entrapment protection provisions of UL 325.

EXTERNAL ENTRAPMENT PROTECTION SENSORS

Most Nice | HySecurity gate operators are equipped with a Type A, Inherent Entrapment Sensor (IES). UL 325 Safety Standard compliance requires an additional means of entrapment protection that includes installation of external entrapment protection sensors, the number of which depends on entrapment hazards that exist at each particular installation.

To comply with UL 325, the following external sensors may be used:

- Contact sensors, such as edge sensors
- Non-contact sensors, such as photo eyes
- Built-in Type C device (Mercury 310 only)

Site designer or installer can choose photo eyes, edge sensors, internal Type C sensor, or a combination of these devices. Whatever devices are used, protection in both opening and closing directions of gate travel must be provided, as well as and where a risk of entrapment is present.

UL 325 Safety Standard for automatic sliding gates specifically requires that edge sensors, photo eyes, or a combination of both devices be installed to protect against pedestrian entrapment in BOTH directions of gate travel and wherever entrapment hazards exist.

PHOTO EYES: One or more non-contact sensor (photo eyes) shall be located where entrapment risk or obstruction exists, such as perimeter reachable by a moving gate.

Care shall be exercised to reduce the risk of nuisance tripping, such as when a vehicle trips the sensor while the gate is moving.

EDGE SENSORS: One or more contact sensors (edge sensors) shall be located at leading edge, trailing edge, and post-mounted, both inside and outside of a sliding gate.

One or more contact sensors shall be located on the inside and outside leading edge of a swing gate. Additionally, if the bottom edge of a swing gate is greater than 6"(152mm) but less than 16"(406mm) above the ground at any point in its arc of travel, one or more contact sensors shall be located on the bottom edge.

SENSOR SECURITY: A hard-wired contact sensor shall be located and its wiring arranged so that communication between sensor and gate is not subjected to mechanical damage.

TYPE A ENTRAPMENT PROTECTION: In Type A entrapment protection, the controller monitors the electrical resistance of the actuator motors, so if a moving gate comes up against the physical resistance of an immovable object, it will cause the gate to stop, hence limiting the force..

TYPE C ENTRAPMENT PROTECTION: In Type C entrapment protection, the controller monitors the actuator encoder output, and if there is an unexpected decrease in speed, it will cause the gate to stop, hence limiting the force.

SENSOR FUNCTION and COMMUNICATION: A wireless sensor that transmits its signal to gate operator must be located so its signal is not impeded by building structures or other obstructions. All sensors must be installed so that they function as intended for end-use conditions.

UL 325 LISTING: Edge sensors and photo eyes must be tested and labeled as "Recognized Components" or otherwise certified to UL 325 requirements in order to

be deemed acceptable for use in a gate operator. Study Important Safety Instructions and consider your specific installation to determine where greatest entrapment risks exist. Locate edge sensors and/or photo sensors accordingly. Be certain that a sufficient number of sensors are used so that pedestrians are protected from entrapment in both directions of gate travel and all hazard areas are fully protected. Most HySecurity gate operators require external entrapment sensors that utilize Normally Closed (NC) contact means of monitoring. HySecurity gate operators utilizing the SmartCNX Controller require external entrapment sensors that have a 10k Ohm or 4-wire pulsed monitoring scheme. Refer to UL website at www.ul.com for most up-to-date list of gate operator safety standards (UL 325). Mercury 310 controller can monitor 10k sensors as well as BlueBus photo eyes.



CAUTION

A contact or non-contact sensor is also required to protect against possible entrapment if gate opens to a position less than 16 inches from any object, such as a post or wall.

RECOMMENDED EXTERNAL ENTRAPMENT PROTECTION SENSORS LIST

UL 325 Standard:

- The operator shall monitor for the presence of every device at least once during each open and close cycle (32.1.8).
- It shall not be possible to make simple modifications in the field by adding, suppressing or changing, either on the operator or external entrapment protection device(s), to bypass, interfere with, or otherwise defeat the monitoring function. (32.1.10).
- Entrapment zones are now defined for each gate type (4.23, 4.24, 4.29, 4.34).

Swing Gates: To enable fully automatic operation, all SWING gate operators will require a minimum of ONE monitored external entrapment protection sensor to protect entrapment zones in either the open or close direction of travel. However, an additional monitored sensor is required if there is a risk of entrapment in both directions of gate travel.

Preferred solution for swing gates: A photo eye for the close direction and/or a hard-wired wraparound edge sensor on the leading edge of the gate, which protects for both directions of gate travel.

IMPORTANT!

Installers must assess each specific site and install sensors that protect all potential entrapment zones.

For more information visit Gate Safety at www.hysecurity.com/gatesafety or see latest operator manuals at <https://support.hysecurity.com/hc/en-us>

MB1050

Installation and Programming Manual

The sensors shown in the table below have been tested with Nice | HySecurity gate operators by an independent laboratory and certified to comply with UL 325 7th Edition. Select sensors from this list for UL compliant gate automation solutions. Contact the sensor manufacturer for specific recommendations for use.



Nice HySecurity Recommended Sensors					Control Boards				
	Mfg. Part # or Model	Brand	Nice Hysecurity Part #	Max Range	Smart Touch	Smart DC	SmartCNX	1050	Mercury 310
Photo Eyes (Retro -reflective)	E3K-R10K4-NR-1	Omron	MX000999	40 ft	•	•	•		
	NIR-50-325	EMX	-	45 ft	•	•	•	•	•
	IRB-RET	EMX	-	53 ft	•	•	•	•	•
	E-931-S50RRGQ	Seco-Larm	-	46 ft	•	•	•		•
Photo Eyes (Thru-Beam)	Blue Bus Era Photo Eyes	Nice HySecurity	EPMB/A EPMOB/A	45 ft			•	•	•
	OVS-50TNR	Optex	-	33 ft	•	•			
	IRB-MON	EMX	MX3990	65 ft	•	•	•		•
	E-960-D90GQ	Seco-Larm	-	90 ft	•	•	•		•
Edge Sensors	Sentir Series	ASO Safety	"AS1502-* AS1501-*"		•	•	•	•	•
	CPT210-2U-#-T2	Miller Edge	-		•	•	•	•	•
Edge Sensor Converters	Hy2NC (Converts 10K to NC Monitoring)	HySecurity	MX4018		•	•			
	GEM103 (Converts 10K to Pulsed Monitoring)	Miller Edge	-					•	
Edge Wireless Kits	iGAZE RE Kit	Transmitter Solutions	-		•	•	•	•	•
	WEL-200	EMX	-		•	•	•	•	•
Multi-Input Module	The Solution – MIM-62	Miller Edge	-		•	•	•		•

Swing Gate Potential Entrapment Zones

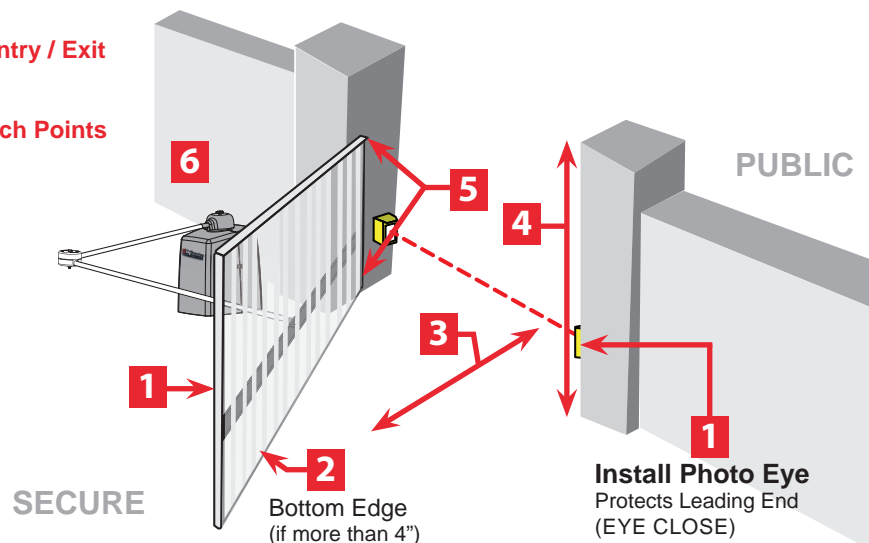
1. Leading Edge
2. Bottom Edge Entry / Exit
3. Posts
4. Post Pivot / Pinch Points
5. Arm Movement
6. Posts

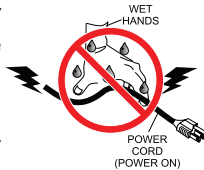

ELECTRICAL SAFETY

- Turn gate operator and all circuit breakers OFF before performing maintenance on the gate operator or making contact with output receptacles. 
- Never insert any objects into output receptacles during operation. The possibility exists of electrical shock, electrocution, or death. 
- Never let power wires lay in water.
- Never use damaged or worn wire when connecting equipment. Inspect for cuts in the insulation.
- Never grab or touch a live power cord or cable with wet hands. The possibility exists of electrical shock, electrocution or death. 
- Always make certain that proper power has been selected for the job. See Cable Selection Chart in this manual.

GROUNDING SAFETY

- Always make sure that electrical circuits are properly grounded to a suitable earth ground (ground rod) per the National Electrical Code (NEC) and local codes. Severe injury or death by electrocution can result from operating an ungrounded operator. 
- Never use gas piping as an electrical ground.





BATTERY SAFETY

HySecurity operators use sealed Absorbed Glass Mat (AGM) batteries and HySecurity highly recommends replacing used batteries with new AGM-type batteries.

CAUTION

Batteries used with HySecurity gate operator contain materials considered hazardous to environment. Proper battery disposal is required by federal law. Refer to *Hazardous Waste Regulations* federal guidelines.

To reduce risk of fire or injury to persons:

- Observe polarity between batteries and charging circuit.
- Never mix battery sizes, types, or brands. Charging circuit on HySecurity DC operators is designed for AGM-type batteries, not flooded lead acid-type batteries.
- Exercise care in handling batteries. Be aware metal found in rings, bracelets, and keys can conduct electricity, short batteries, and cause potential injury. 
- Do not open or mutilate batteries. Battery cells contain corrosive materials which may cause burns and other injuries. Material within batteries is toxic. 
- Always dispose of batteries properly. Do not place batteries in fire. Battery cells may explode. Follow federal guidelines for proper disposal of hazardous waste. 
- Always keep battery cables in good working condition. Repair or replace all worn cables.
- Replace batteries according to instructions found in *DC Battery Replacement*. 
- Do not charge frozen battery. Battery can explode. If frozen, warm the battery to at least 61°F (16°C).

ENVIRONMENTAL SAFETY/HAZARDOUS MATERIALS AND PROPER DISPOSAL

Decommissioning is a controlled process used to safely retire a piece of equipment that is no longer serviceable. If the equipment poses an unacceptable and unrepairable safety risk due to wear or damage or is no longer cost effective to maintain (beyond life-cycle reliability) and is to be decommissioned (demolition and dismantlement), be sure to follow rules below. 

- Do not pour waste or oil directly onto the ground, down a drain or into any water source.
- Contact your country's Department of Public Works or recycling agency in your area and arrange for proper disposal of any electrical components, waste or oil associated with this equipment.
- When the life cycle of this equipment is over, remove battery and bring to appropriate facility for lead reclamation. Use safety precautions when handling batteries that contain sulfuric acid.
- When the life cycle of this equipment is over, it is recommended that the frame and all other metal and plastic parts be sent to a recycling center.

Metal and plastic recycling involves the collection of metal and plastic from discarded products and its transformation into raw materials to use in manufacturing a new product.

Recyclers and manufacturers alike promote the process

of recycling metal and plastic. Using a metal and plastic recycling center promotes energy cost savings.

WIND LOAD

When the IES (type A sensor) trips, it sends a signal to gate operator to stop and reverse direction. This feature may be falsely triggered in excessively windy conditions because wind itself, acting over surface area of gate panel, can provide necessary force to trigger IES.

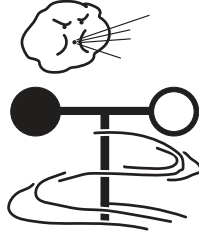

CAUTION

Do not adjust IES sensitivity/Force setting to accommodate for inappropriately designed gate panels. Loss of IES sensitivity increases mechanical wear on gate hardware and gate operator. It may also pose a safety hazard. Compensating for wind loads by adjusting IES may set IES sensitivity to a level which, when encountering an obstruction, ignores obstruction and fails to reverse direction.

MAINTENANCE OF GATE SYSTEMS

To keep your automated gate system performing both safely and reliably it is important to ensure that the components of that system are functioning properly.

At least monthly:

- Disconnect the gate operator and manually move the gate through its range of travel. Note any squeaks from rollers or hinges or areas of binding. The gate should travel smoothly and quietly throughout its range. If it does not, contact a gate professional to correct the problem.
- Reconnect the gate operator and perform the following tests:
 - With the gate opening, block any photo eyes and/or depress any safety edges used to protect the open direction. The gate should stop and/or reverse.
 - With the gate closing, block any photo eyes and/or depress any safety edges used to protect the close direction. The gate should stop and/or reverse.
 - Using a suitable obstruction in the path of the gate (a solid, immovable object), run the gate in the open direction until it contacts the obstruction. The gate should stop and reverse, or it will just stop if a Type C sensor is engaged before the Type A sensor is tripped.
 - Using a suitable obstruction in the path of the gate (a solid, immovable object), run the gate in the close direction until it contacts the obstruction. The gate should stop and reverse, or it will just stop if a Type C sensor is engaged before the Type A sensor is tripped.

SECTION 4: INSTALLATION SAFETY

IMPORTANT!

- The gate operator installation is NOT a “do-it-yourself” project. Contract a qualified gate operator installation company to install this system to ensure a safe and reliable installation.
- It is the responsibility of the property owner to ensure the installer is qualified to carry out the installation in a safe and professional manner.
- Consult local government agencies for up-to-date rules and regulations to satisfy licensing, codes or regulations that regulate automated gate system design and installation.
- The gate for which the gate operator is intended to be used should itself be installed correctly so that it is level and plumb and the gate opens easily and evenly.
- Note that Nice swing gate systems are not intended for installation on an incline.



CAUTION

- Disconnect power at the control panel before making any electric service power connections.
- Be aware of all moving parts and avoid close proximity to any pinch points.

SECTION 5: TOOLS & MATERIALS NEEDED

Below is a list of tools and materials necessary for installation of the control box:

- Wire cutters/strippers
- Basic hand tools (screwdrivers, wrenches, pliers, etc..)
- Drill and assorted size bits
- Hardware for mounting control box
- Electrical conduits, grommets, asphalt patch, etc. as needed

SECTION 6: CONTROL BOX INSTALLATION

1

MOUNT CONTROL BOX

1. The MB1050 comes with four mounting feet attached to the enclosure using 1/4-20 x 1/4" screws.
2. Mount control box on same side as primary actuator (for dual gate systems, same side as the actuator with shorter harness) and at least six feet away from pivot arm (IMAGE 1).

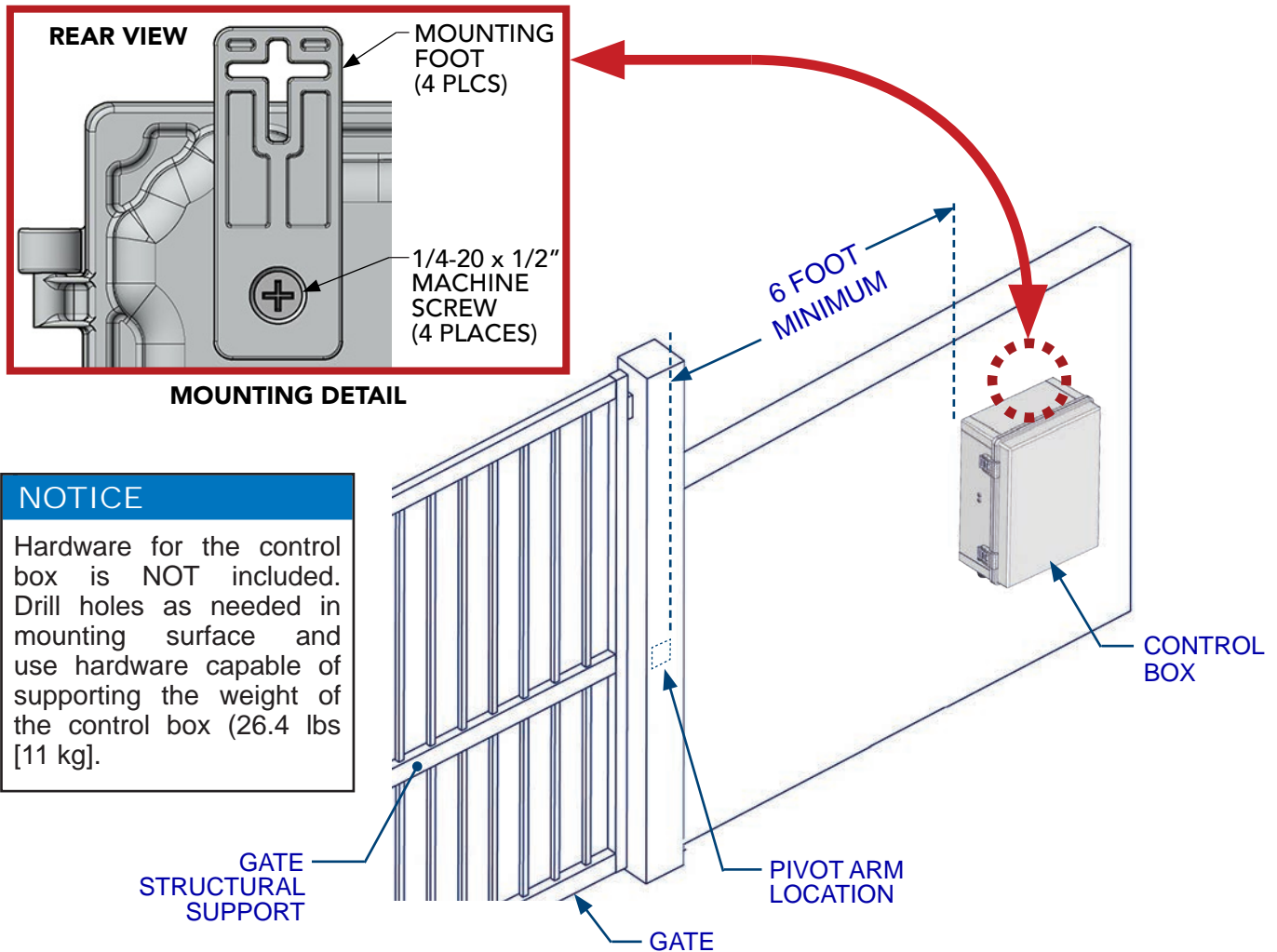

CAUTION

Do not mount the control box where the person using the push button on side of box can come in contact with the gate!

2

ACCESS INTERIOR OF THE MBOX1050

1. Access the interior of the MBOX1050 by unlatching the two door latches per IMAGE 2-1.

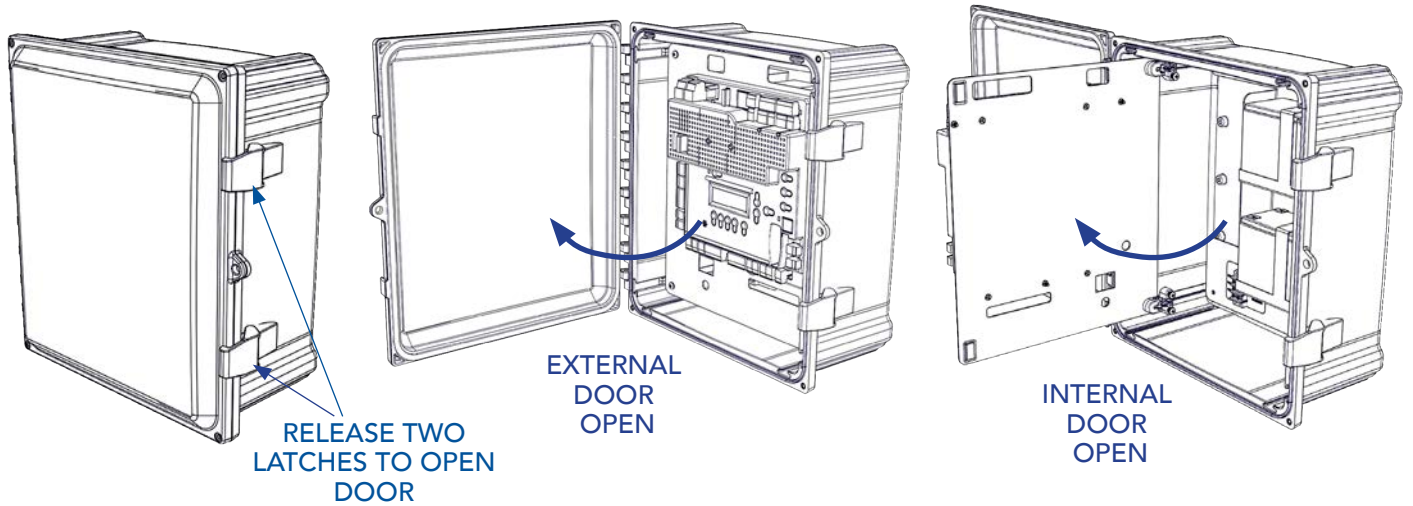

IMAGE 2-1: ACCESSING THE MB1050 INTERIOR

NOTICE

After installation or maintenance operations, always re-latch the door fasteners to maintain security of the system and to ensure an adequate seal of the cover.

2. The internal door is secured by two magnets. Open the internal door to access power supply, batteries, audio alarm, and power connections by placing fingers into wire pass-through slots, pulling (to disengage magnets), and swinging to left as shown in IMAGE 2-1. Refer to IMAGE 2-2 for internal features.

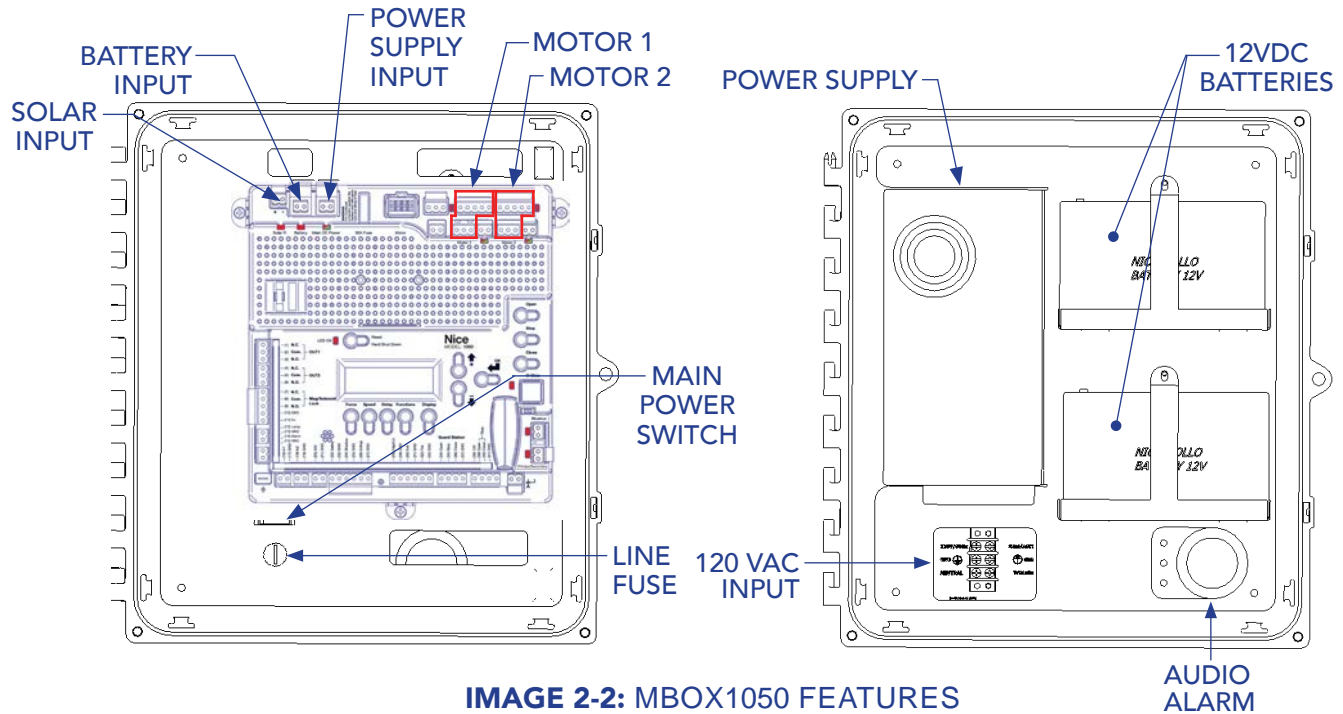

IMAGE 2-2: MBOX1050 FEATURES

3

INSTALL ACTUATOR & RUN CABLE(S) TO BOX

1. Refer to the installation manual for your chosen actuator(s) and install per the instructions.
2. For a single gate installation, run the cable of the actuator through one of the holes (using cord grip from kit) through the bottom on the control box.
3. For a dual gate installation:
 - a) Dig a trench across the driveway deep enough to accommodate the longer harness cable from the actuator farthest from the control box.
 - b) Run the cable through a conduit and lay this in the trench.
 - c) Cover the trench and use asphalt patch if needed.
 - d) Run the 2nd cable into a hole (using cord grip from kit) through the bottom of the control box.

NOTICE

Ensure cables reach into the control box sufficiently to reach the MOTOR inputs on the control board.

4

WIRE ACTUATOR(S) TO CONTROL BOARD

NOTICE

Refer to actuator install manual for specific instructions for wiring the actuator to the 1050 controller.

1. Strip actuator wires back 3/8"-7/16" (10-11mm) and twist.
2. Remove 5-pin and 3-pin connector from the MOTOR 1 section on control board. If a dual gate system, also remove both MOTOR 2 connectors. See IMAGE 4.
3. Refer to wire diagram in appropriate actuator install manual, then use a small flat blade screwdriver to affix wires into screw terminals of connectors per wire diagram.

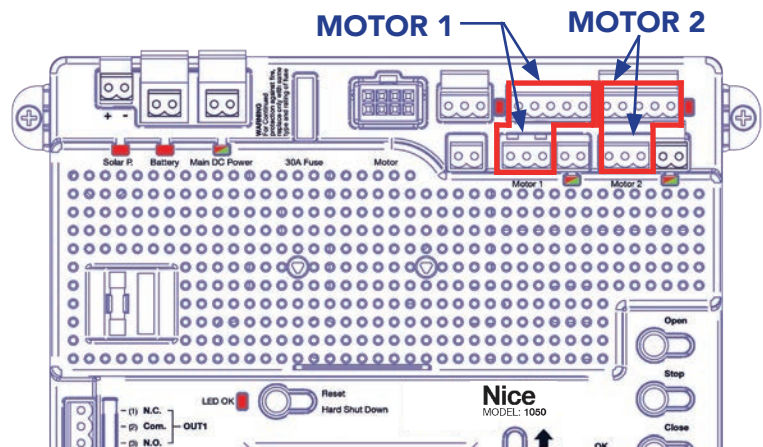

IMAGE 4: MOTOR CONNECTORS

4. Plug in the wired connector to MOTOR 1 when finished. For dual gate systems, DO NOT connect the MOTOR 2 connector to the control board yet. MOTOR 2 connector will be connected at a later step.

NOTICE

- If for a dual gate system, prepare both actuator harnesses per these instructions.
- Note that connections are different for Pull-to-Open and Push-to-Open installations.
- If a gate moves in opposite direction from what is expected, reverse the motor power lead wiring (red & black wires) for that motor.

5

DETERMINE BLUEBUS PHOTO EYE LOCATIONS

See below for suggestions of photo eye positioning for your gate configuration.

NOTICE

Images 5-1 and 5-2 (below) show suggested sensor locations for both the EPMB/A (thru-beam pair photoeye) and EPMORB/A (reflective photo-eye). Name designations (P1, P2, etc.) are arbitrary designations used to indicate jumper settings for each photo eye location.

Refer to Instruction 4 on next page for EPMB/A installation instructions and jumper settings.

Refer to the documentation included with the EPMORB/A photo eye for installation instructions for that device, although jumper settings in Instruction 6 are the same for both BlueBUS photo eyes.

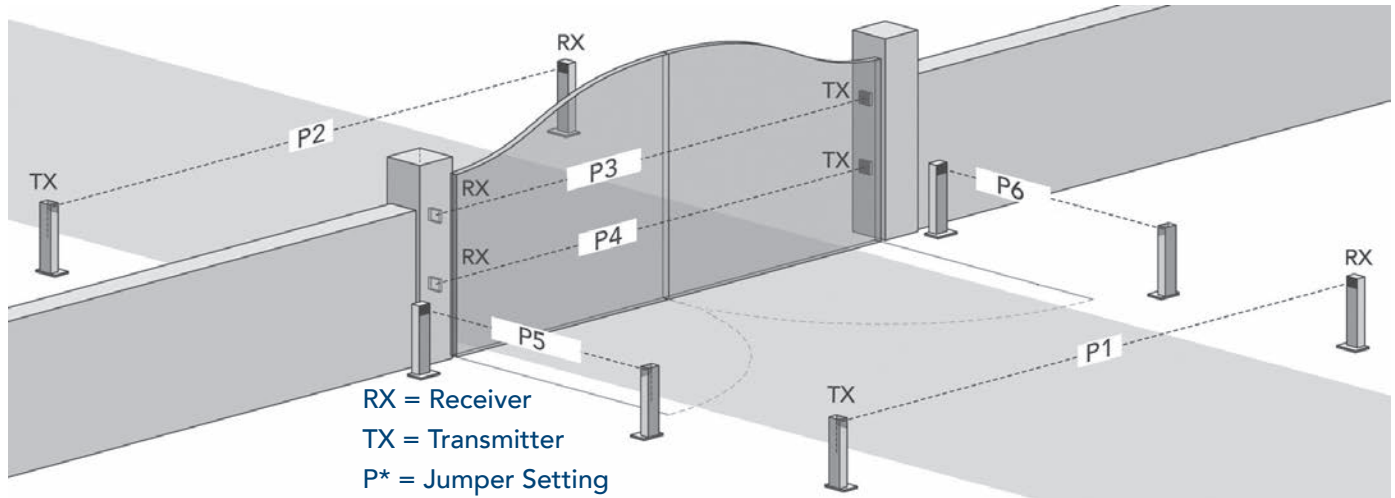

IMAGE 5-1: POSSIBLE ENTRAPMENT ZONES AND PHOTO EYE LOCATIONS

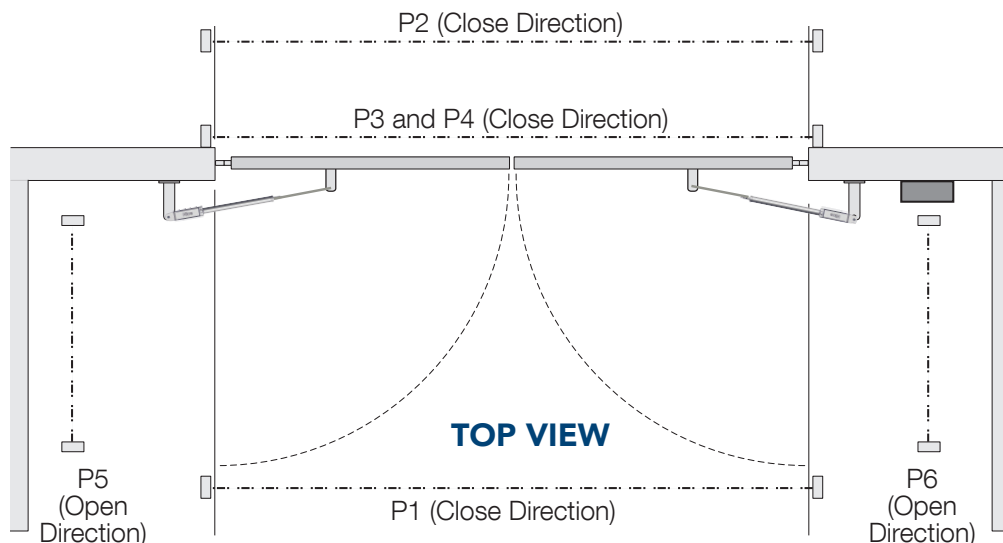

IMAGE 5-2: POSSIBLE ENTRAPMENT ZONES AND PHOTO EYE LOCATIONS (TOP VIEW)

MB1050

Installation and Programming Manual

NOTICE

Each pair of BlueBUS photo eyes wired to the same gate operator must use a different jumper configuration for each pair (six maximum). Photo eye jumper settings perform as follows (refer to IMAGE 5-1 and 6-1, below).

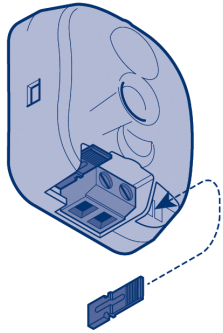

IMAGE 6-1: BLUEBUS PHOTO EYE JUMPER SETTINGS

P1 - P2 (Close Dirction) Hold gate open - reverse gate if closing.		P3 - P4 (Close Direction) Hold gate open - stops gate if closing and reverses back open when eye is cleared.	
P5 - P6 (Open Direction) Keep gate from opening - reverse gate back closed.		NOT USED	

IMPORTANT!

The 1050 controller must have at least one monitored and functioning safety device connected to the control board in order to function. Before power is connected to the control board, install the BlueBUS photo eyes provided in the kit.

The instructions below are for the EPMB/A thru-beam pair, which requires installing a transmitter and receiver. The EPMORB/A uses a transmitter and reflector instead, but general installation, wiring, status, troubleshooting, and maintenance are the same for both. See separate EPMORB/A installation instructions for details on mounting the reflector.

6

PREPARE BLUEBUS PHOTO EYES FOR INSTALLATION

1. Remove top cover (A) and faceplate (B), then use screwdriver to remove inner assembly from bracket (C).

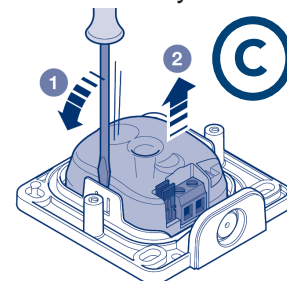
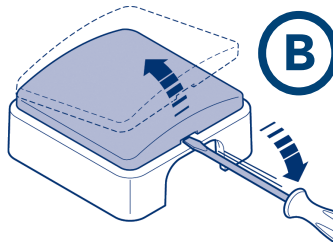
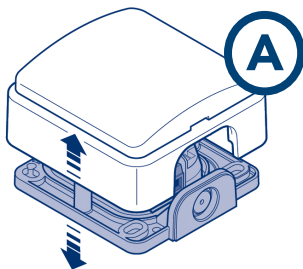

2. Knock out the four plastic tabs from mounting holes (D), then remove appropriate tab from wire entry hole (E); knock out rear tab for running wire inside the mounting wall OR knock out bottom tab for running wires out the bottom.

3. If more than one pair of photo eyes, configure jumpers so that each pair has a unique jumper setting (six maximum). Stow unused jumpers in slots on photo eye rear (Image 6-1).

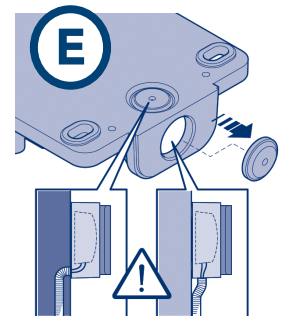
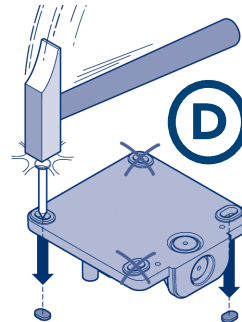

7

INSTALL & WIRE BLUEBUS PHOTO EYES

1. Ensure alignment between receiver and transmitter brackets (F), then affix both to selected locations with included screws (G).

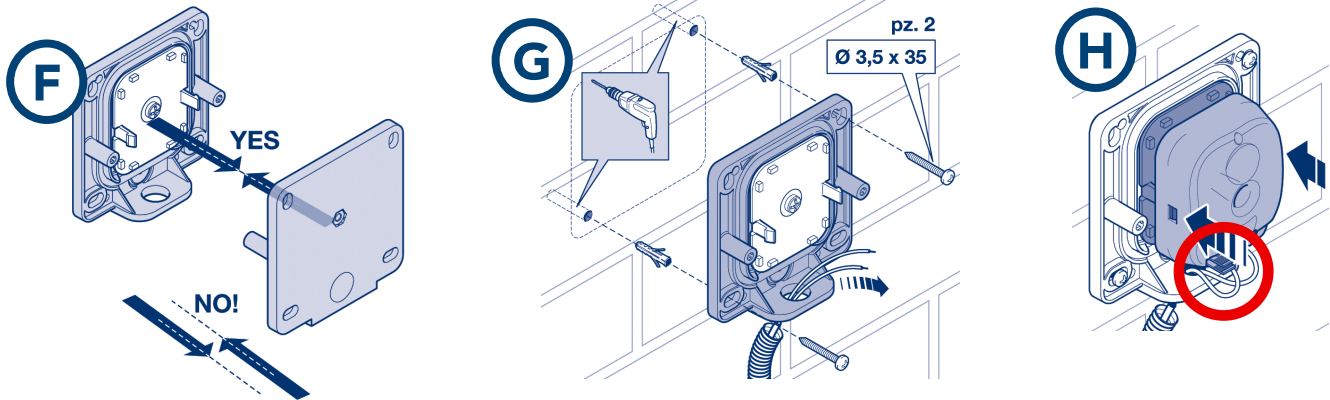

IMPORTANT!

If using the model EPMB/A non-adjustable photo eye, ensure the mounting surfaces for both devices are parallel with each other to ensure accurate alignment between transmitter and receiver.

2. Thread 2-conductor jacketed cable through bracket hole and snap photo eye assembly (H) into bracket.
3. Install wires into screw terminals (H, red circle) in parallel as shown (I). No polarity required.

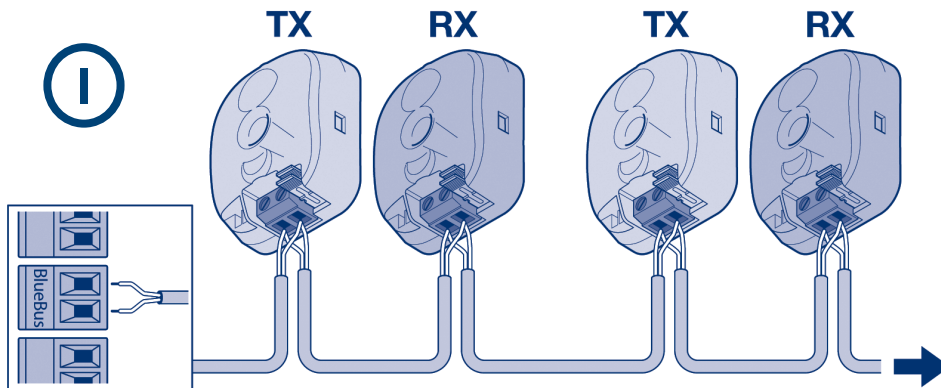

NOTICE

- Maximum total length of wire should not exceed 165 feet (50 meters).
- When replacing photo eyes, jumper setting on the new device must match the old device to avoid having to re-learn the BlueBUS configuration.

8

CONNECT BLUEBUS PHOTO EYES TO BOARD

Install through beam photo eye bus wires (no polarity) into 2-pin BlueBUS connector on control board (IMAGE 8). If an alternative photo eye is used, follow installation instructions included in the kit.

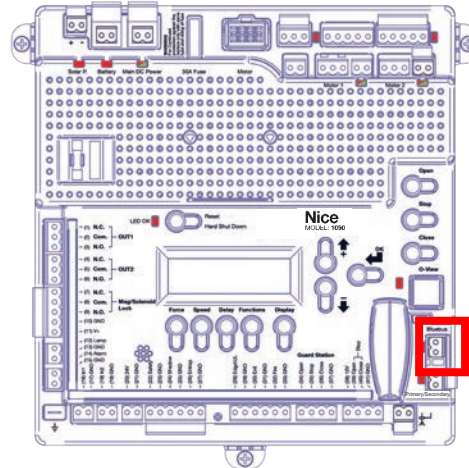

IMPORTANT!

If using the model EPMB/A non-adjustable photo eye (H), Do not attempt to jumper or short the BlueBus connector pins as this will damage the control board.

← BLUEBUS CONNECTOR

IMAGE 8: BLUEBUS CONNECTOR LOCATION

9

ATTACH WARNING SIGNS TO GATE

- Place one warning sign (IMAGE 9-1) on outside of gate and the other inside of gate in high visibility locations (eye height) to warn of entrapment dangers. If signs cannot be attached to gate, ensure they are as visible as possible to pedestrians and anyone operating the gate.
- Use two tie wraps per sign, or alternative means, to securely affix signs to gate.



IMAGE 9-1: GATE ENTRAPMENT WARNING SIGN

SECTION 7: CONTROL BOX POWER WIRING

The MB1050 features an AC-to-DC 12-24 VDC power supply, two 12 VDC 20AH batteries, and an option to add solar panels. The basic power flow through the MB1050 system is displayed in the diagram below:

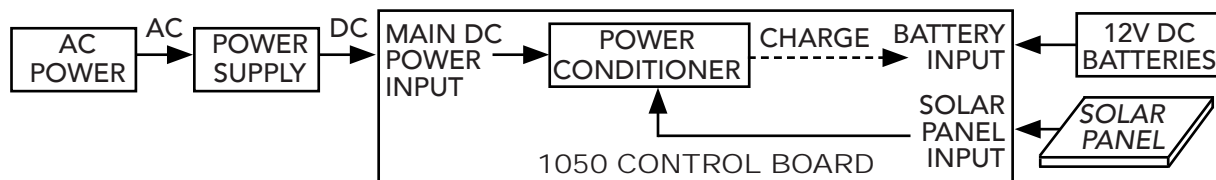

The 1050 control board features an internal power conditioner to charge the batteries from either the power supply or optional solar panels. The board will run from the batteries during an AC power failure.

7.1 120 VAC ELECTRICAL WIRING SAFETY

The 1050 control board operates ONLY on DC power from the battery or from the Main DC Power input. Follow all safety warnings if installing AC power for conversion to DC for charging purposes or for powering the board. Nice offers optional charging solutions.

DANGER!

- To reduce risk of severe injury and death follow all safety procedures!
- Do not wire AC mains power to metal control box without earth ground connection!

CAUTION

Do not wire ac power to the control board! The control board operates on 12 VDC or 24 VDC only!

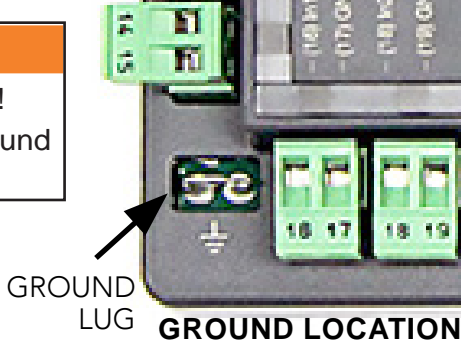

- Disconnect power to the gate operator by manually opening its dedicated circuit breaker before making any mechanical or electrical adjustments.
- Use a 20 amp dedicated circuit breaker for each installed gate operator.
- Open dedicated circuit breaker supplying power to gate operator before a new installation or making any modifications to an existing installation of this gate operator.
- All wiring connections must be made by a qualified individual.
- Run individual circuits in separate UL Listed conduits. Do not combine high voltage (120 VAC) power wiring and low voltage (+12 VDC to +24 VDC) control wiring in the same conduits.

If AC power is being run into the control box for conversion to DC, the gate operator system should be grounded through the earth ground in the ac mains wiring system (green wire).

This ground connection will prevent dangerous currents from appearing on the metal control box, the actuator, or the gate itself.

Nice recommends an 8 foot copper rod driven all the way into the ground with a copper clamp and 12ga copper wire minimum.

Connect ground wire to the grounding lug on the lower left corner of the 1050 control board (FIGURE 4-1). Alternatively, bonding of the control box can be done by drilling a hole in the control box, removing the powder coating around the hole, and bonding the copper ground wire to that area with a bolt.

1.1 HIGH VOLTAGE WIRE GAUGE REQUIREMENTS

Use Table below to determine high voltage wire size requirements. Distance shown in the chart is measured from the operator to the power source. If power wiring is greater than the maximum distance shown, a service feeder is recommended. When large gauge wire is used, a separate junction box must be installed for the operator connection.

Wire table is based on stranded copper wire. Wire run calculations are based on a 110 VAC power source with a 3% voltage drop on the power line, plus an additional 10% reduction in distance to allow for other electrical losses in the system.

TABLE 12-1: MAXIMUM RUN PER WIRE GAUGE						
110V/AWG GAUGE	14	12	10	8	6	4
MAX RUN	180 FT (54.8m)	280 FT (85.3m)	460 FT (140m)	700 FT (213.3m)	1150 FT (350.5m)	1800 FT (548.6m)

7.2 CONNECTING AC POWER TO THE MB1050

There are three power configurations available to power the 1050 control board:

- Powered by 12 VDC batteries (and charged ONLY by solar panel)
- Powered by 12 VDC batteries (and charged by on-board AC-DC power supply)
- Powered directly from the on-board AC-DC power supply without using batteries or solar panels.



DANGER

Do not connect AC power directly to main DC power connector on control board! The board accepts only 10-35 VDC!

IMPORTANT!

Power should not be applied to the control board until after the photo eyes have been installed and wired to the control board. Power is applied in INSTRUCTION 12.

10

CONNECT AC POWER TO MBOX1050

1. Ensure the MB1050 power switch is turned OFF (O).
2. Run AC source cable into hole in bottom of control box, using the included cord grip.
3. Unsnap and remove clear plastic cover from power terminal block.
4. Using best wiring practices, connect incoming power to the power terminal screws as shown in IMAGE 10.
5. After wiring, snap clear plastic cover back onto power terminal.

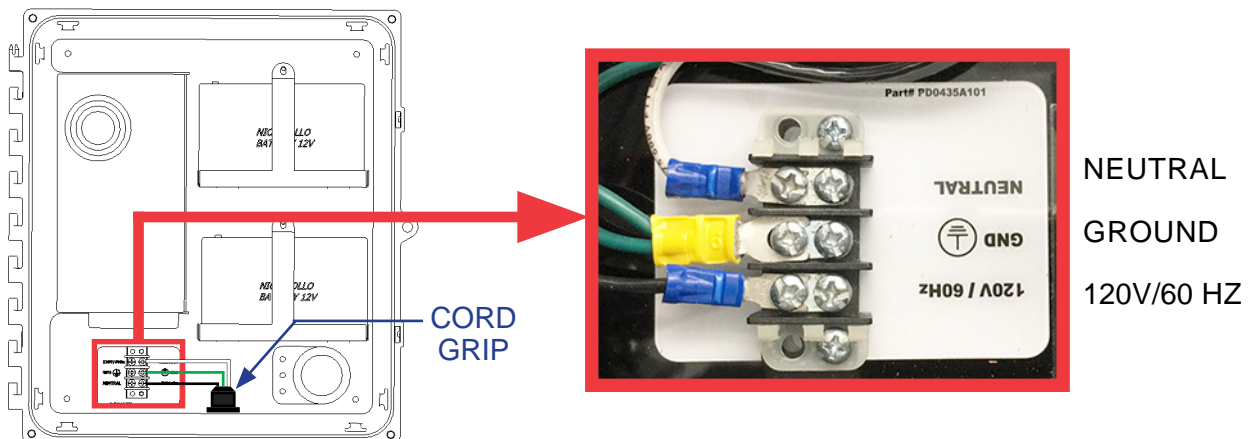

IMAGE 10: INCOMING AC POWER CONNECTIONS

11A SOLAR PANEL CONNECTION - 10W TO 20W

A 20 Watt, or smaller, solar panel may be installed to enable battery charging through the 1050 control board's integral regulator/conditioner as follows:

1. Assemble solar panel mounting bracket and panel with included hardware.
2. Locate solar panel out of shadows of surrounding buildings, walls, etc. and orient to collect the maximum sunlight energy throughout the year. In the northern hemisphere, mount panels at upward angle of about 45 degrees with panel oriented south. In the southern hemisphere orient the panel to face north.
3. Cut off two battery lugs from the end of the solar panel cable.
4. Run the solar cable into hole (with rubber grommet) on underside of MB1050, ensuring cable reaches the control board.
5. Strip wires back 1/4"-5/16" (7-8mm), twist, and install into the solar panel connector screw terminals on the control board (RED = +, BLACK = -). See IMAGE 11A.

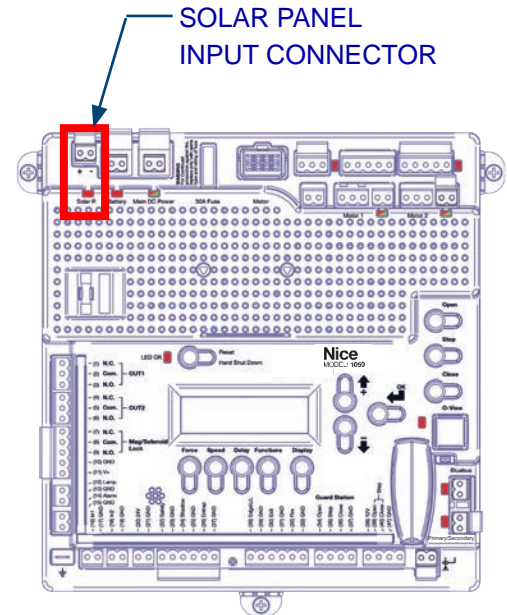

IMAGE 11A: SOLAR CONNECTORS ON CONTROL BOARD

NOTICE

- Turn ON Standby Mode (INSTRUCTION 13) if using only solar power to charge battery.
- If solar panel is wired backwards, a red LED will illuminate above the connector.

NOTICE

For 30W solar panels and above, an external regulator must be used. Nice offers a regulator (P/N SG-4) for this purpose. See INSTRUCTION 9B for installation instructions for the SG-4 regulator.

11B SOLAR PANEL CONNECTION - 30W AND ABOVE

Solar panels of 30W and above must be connected to a regulator which, in turn, then connects to the battery to enable battery charging. Nice offers a regulator (P/N SG-4) for this purpose. For regulators sourced elsewhere, follow the manufacturers instructions when installing. Install and wire the 30W and above solar panels and SG-4 regulator as follows:

1. Assemble solar panel mounting bracket and panel with included hardware.
2. Locate solar panel out of shadows of surrounding buildings, walls, etc. and orient to collect the maximum sunlight energy throughout the year. In the northern hemisphere, mount panels at upward angle of about 45 degrees with panel oriented south. In the southern hemisphere orient the panel to face north.
3. Mount the SG-4 in the MB1050 enclosure at bottom next to the audio alarm or at top of enclosure above the batteries. Use hardware or other means to properly affix it.
4. Wire by connecting the red wire of solar panel to the yellow wire of the regulator and the black wire of solar panel to either of the regulator's black wires (see IMAGE 11B).
5. Connect the red (positive) battery wire (see notes below) to the red wire of the battery regulator and the black battery wire (negative) to the other black wire on the regulator, then attach both battery lugs to the battery (red to positive and black to negative). See IMAGE 11B).

NOTICE

- Wire-to-wire connections may be made using wire nuts, crimp caps, or butt connectors, as long as the connections are secure.
- It is permissible to cut off 8" to 10" (or so) of the solar panel wires (with battery lugs) in order to use for attaching the regulator to the battery.
- The SG-4 prevents reverse current leakage at night, so a blocking diode is not required in the system.
- A negative earth ground at the battery is recommended for most effective lightning protection.
- The SG-4 can be mounted outdoors, but do not expose to ambient temperatures above 140°F (60°C).
- Ensure that water is able drain from inside the case if it becomes wet.

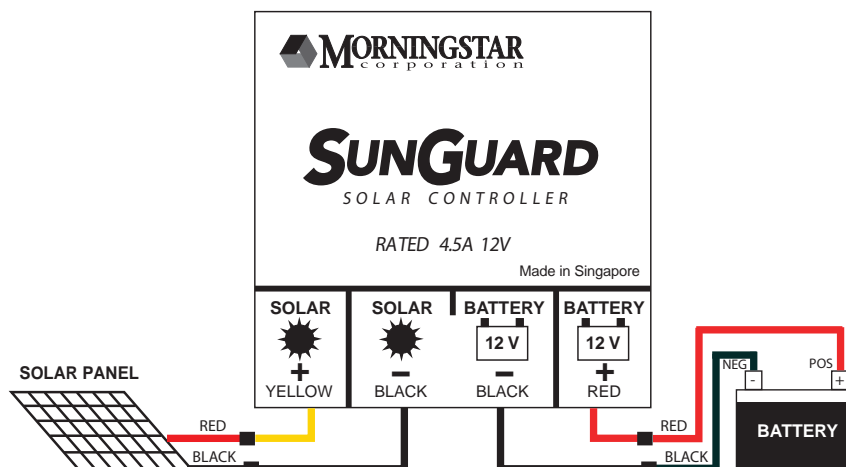

IMAGE 11B: P/N SG-4 SOLAR PANEL REGULATOR WIRING

12

POWER UP CONTROL BOARD

After performing all previous instructions, turn on (I) the power switch and the control board should power up as follows:

1. After applying power, the display will show:
 - a) the company name, followed by...
 - b) the firmware version, then...
 - c) **“Scanning BlueBUS”** as the control board is scanning for compliant safety devices.
2. If safety devices (such as photo eyes) are found and determined to be functional, then display defaults the current gate status (Open or Close) indicating the board is ready to “Learn” the gate limits and you may proceed to INSTRUCTION 13.
3. If no safety devices are attached or functioning, display will show **“BlueBUS Error”**.
4. If using the BlueBUS photo eyes when error is displayed, check for BlueBUS wiring errors and/or observe diagnostic LEDs per INSTRUCTION 15 to determine problem. If using the reflective photo eye with reflector, refer to the separate instructions included in the kit for troubleshooting instructions.
5. To reset the board after a scanning error (**BlueBUS Error**), remove power from the board (unplug battery connector) then after a few seconds reapply power (plug in battery connector).
6. Board will display **“Scanning BlueBUS”** while it scans for monitored safety devices.
7. If safety devices (such as photo eyes) are found and determined to be functional, then display defaults to the current gate status (Open or Close) indicating the board is ready to ‘learn’ the gate limits, and you may proceed to INSTRUCTION 13.
8. If safety devices provided in the kit are determined to be defective, contact Nice technical support.



CAUTION

These operators are all 12V operators and the MB1050 is by default a 24V controller. Be sure to turn ON the Motor 12V setting under the FUNCTION BUTTON/Advanced Settings in SECTION 8 prior to operation if powering one of these operators.

NOTICE

Until the control board has “LEARNED” the ACTUATOR open/close limits, the OPEN and CLOSE buttons must be pressed and HELD DOWN to operate the gate(s). Once limits are learned by the control board, it will take only a single press (and release) to fully open or close the gate.

13

GATE LIMIT LEARNING PROCEDURE

The LIMIT LEDs light GREEN when OPEN limit is reached and RED when CLOSE limit is reached. There is a separate LED for each input connector, MOTOR 1 and MOTOR 2. Refer to IMAGE 13-1 for location of OPEN and CLOSE limit indication LEDs on the control board.

IMPORTANT!

In a dual gate systems, only one actuator harness should be connected at a time to the control board at this point. Do NOT OK the LEARN function until reaching Step 11.

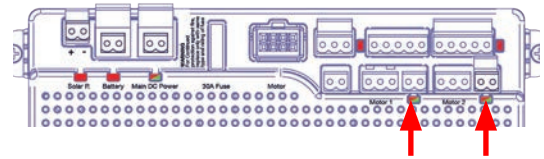

IMAGE 13: OPEN/CLOSE LIMIT LEDs

1. Control board should be powered. If not, apply power per INSTRUCTION 10, 11A, and/or 11B.
2. If a dual gate system, ensure ONLY ONE of the actuators is connected at a time.
3. Press the FUNCTION button to access the LEARN option, and press OK button.
4. Use UP and DOWN buttons to select gate **type** (slide or swing) and press OK button,
5. Use UP and DOWN buttons to select gate **weight** (light, medium, or heavy) .
6. Press OPEN or CLOSE buttons on the control board to ensure gate opens and closes in the desired direction. If gate opens in the opposite direction as expected, reverse red and black motor leads in the actuator wiring.

NOTICE

Before the learning process, gates should only move for as long as buttons are held down and stop when buttons are released.

7. Press and hold down OPEN and CLOSE buttons on board to check that limit LED lights RED when gate reaches the close position, and GREEN when gate reaches open position (IMAGE 13-1). If limits are not adjusted properly, refer to the actuator instructions for the actuator you are using to fine tune the open and close limits. Note that if limit LED lights up with wrong color at gate limit, reverse the orange and white limit leads in the actuator wiring.
8. Press OPEN or CLOSE buttons on the control board till gate is in approximately the halfway position.
9. If dual gate system, unplug the first actuator, plug in the second actuator and **repeat Steps 3-5**.

(Continued)

13: GATE LIMIT LEARNING PROCEDURE (CONT.)

10. If dual gate system, plug both actuator motor connectors into Control Board, ensuring that the second actuator with longer cable is plugged into MOTOR 2 connector.
11. Press OK when “**Learn**” is displayed to allow operator to begin the learning process.
12. The board automatically begins the limit learning process and the gate(s) moves automatically as follows:
 - a) A short opening sequence to determine number of motors.
 - b) A full closing cycle at half-speed to determine close limits (CLOSE LED lights at close position).
 - c) A full opening cycle at half-speed to determine open limits. (OPEN LED lights at open position).
 - d) A full closing cycle at full-speed into the closed position. (CLOSE LED lights at close position).
13. The OPEN and CLOSE buttons can now be pressed once (without holding) to fully open and close the gate(s).
14. Check the position of each gate in its fully closed and open positions and if further adjustment of open/ close limits is necessary, refer to the appropriate actuator manual.
15. If gate limits are acceptable, proceed to next instruction.

NOTICE

- If a gate moves in opposite direction from what is expected, reverse the motor power lead wiring (red & black wires) for that motor. If the wrong limit LED lights (i.e. the close LED lights when gate at open limit), reverse the limit wires (reverse orange and white) on the actuator motor connector.
- By default, there is a 10 second delayed “Auto Close”, so after 10 seconds of being open, the gate will again close. This can be changed and set in the control board options as described in later instructions.

14

SELECT CONTROL BOARD STANDBY MODE

IMPORTANT!

For SOLAR APPLICATIONS - Turn the Standby Mode ON.

STANDBY MODE puts the board into a "Low Power Consumption Standby Mode". Press any button to "wake" the board. Select ON or OFF as follows:

1. Press FUNCTION button.
2. Scroll to "Standby" menu (8th menu).
3. Press OK.
4. Use UP and DOWN buttons to select desired amount of time before system enters "Standby Mode". 20-30 seconds is the recommended setting.
5. Press OK.
6. Once this is done, the operator will enter a Standby Mode after the set time when the operator is not moving, it is either in the auto-close countdown or is being held open by an external auxiliary input.

NOTICE

- When display is OFF In Standby Mode, only a "heartbeat" will be present at the OK LED.
- Voltage at terminal #20 (24 VDC) and terminal #38 (12 VDC) will turn off - do not power entry or exit devices from these outputs.
- BlueBUS function is disabled until board "wakes" up. Press any button to wake.

NOTICE

Status indication and troubleshooting are identical for BlueBUS photo eye models EPMB/A and EPMORB/A.

15

BLUEBUS PHOTO EYE STATUS & TROUBLESHOOTING

Once BlueBUS photo eyes are recognized by the control board, the photo eye LED behavior should be checked and adjustments made as follows:

1. After power up and all BlueBUS devices are recognized, observe LED behavior in each photo eye.
2. SLOWLY flashing LEDs indicate photo eyes are operating properly.
3. If LEDs indicate improper detection by the control board, poor transmission, or no signal, refer to troubleshooting Table 1-1, below. Continue to next section for instructions for adjustment of photo eye transmitter and receiver alignment.

TABLE 14-1: PHOTO EYE LED STATUS AND TROUBLESHOOTING

LED STATUS	MEANING	ACTION
Always off	(TX, RX) – The photo eye has no power supply or is faulty.	Check that on the terminals of the photo eye there is a voltage of approximately 8 to 12 V DC. If the voltage is correct, it is likely that the photocell is faulty.
3 quick flashes, (pause)	(TX, RX) – The pair of photo eyes has not been memorized in the control unit (or the interface).	Make sure that each pair of photo eyes has a different jumper configuration than the others. Perform the device learning procedure (INSTRUCTION 12).
Very slow flashing	(TX, RX) – The TX is transmitting properly. The RX is receiving an optimum signal.	None; optimum transmitter and receiver/reflector alignment.
Slow flashing	(RX) – The RX is receiving a good signal.	None; good operation.
Fast flashing	(RX) – The RX is receiving a weak signal.	Fair operation; the photo eye glass should be cleaned or the photo eye re-aligned.
Very fast flashing	(RX) – The RX is receiving a poor signal.	Barely operational; clean the photo eye glass and realign the transmitter and receiver/reflector.
Always on	(TX, RX) –The RX is receiving no signal.	Check if there is an obstacle between the transmitter receiver/reflector; clean the photo eye glass and realign transmitter and receiver/reflector.

16

BLUEBUS PHOTO EYE ALIGNMENT

If adjustment of photo eye alignment is necessary, refer to the following instructions:

NOTICE

- Photo eye testing is described in INSTRUCTION 17.
- Adjustment instructions apply only to EPMOB/A and EPLOB/A models. EPMB/A model is not adjustable, and must be adjusted using mechanical means left up to the installer.

1. Pull off front cover from photo eye assembly.
2. Use medium Phillips screwdriver to loosen screw (A).
3. Place screwdriver in hole (B) and lever the entire assembly in desired direction to change the angle of the assembly by up to 15 degrees in all directions (30 degrees total).

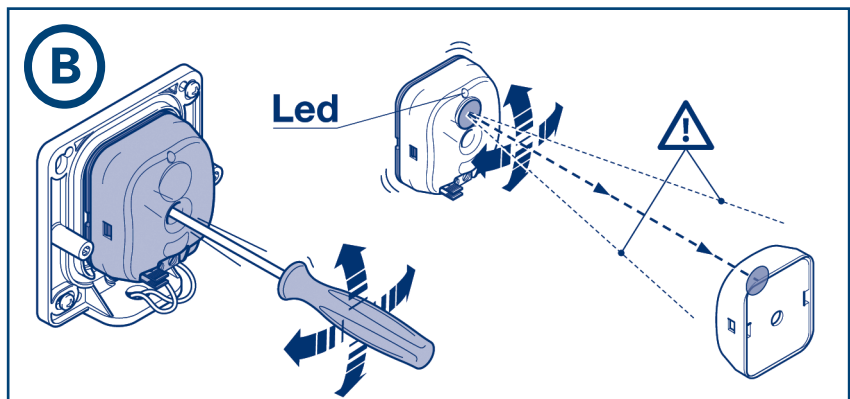
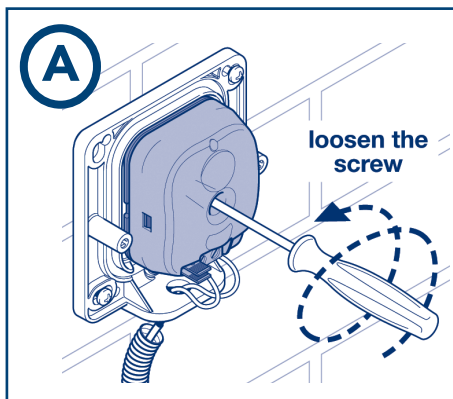

4. Observe LED behavior during adjustment and stop adjustment when LED flashes very slowly.
5. Re-tighten screw (C). Do not replace covers till after photo eye testing is performed later in these instructions.

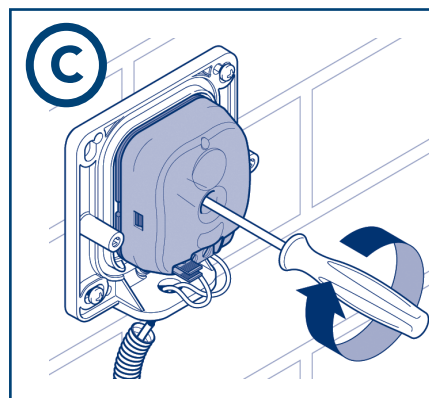

17

PHOTO EYE TESTING

NOTICE
This test is applicable for all thru-beam and reflective photo eye devices.

Photo eyes must be tested after power is applied to the control board to ensure proper operation:

1. Apply power to control board and ensure photo eye devices are detected and functioning.
2. Press the gate OPEN or CLOSE button on the control board to set gate in motion for each test.
3. Use a hand held cylinder of approx. 2" (5cm) diameter and 12" (30cm) in length and pass between photo eye line of sight as follows:

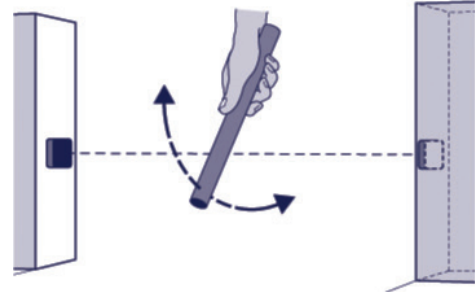

IMAGE 17-1: CYLINDER TESTING

- a) Pass cylinder through line of sight near transmitter.
- b) Pass cylinder through line of sight near receiver/reflector.
- c) Pass cylinder through line of sight halfway between transmitter and receiver/reflector.
4. Each time the line of sight between transmitter and receiver/reflector is obstructed, the gate motion should immediately stop, then reverse direction.
5. If the gate does not react properly when photo eye line of sight is blocked, refer to INSTRUCTION 14 to determine the problem and applicable action.

18

BLUEBUS PHOTO EYE FINAL ASSEMBLY

If photo eyes have been tested and are working correctly, photo eye installation may be completed as follows:

1. Ensure rubber rear gasket is in position, then affix photo eye cover to assembly with hardware (A).
2. Ensure rubber front gasket is in position, then snap in face plate (B).

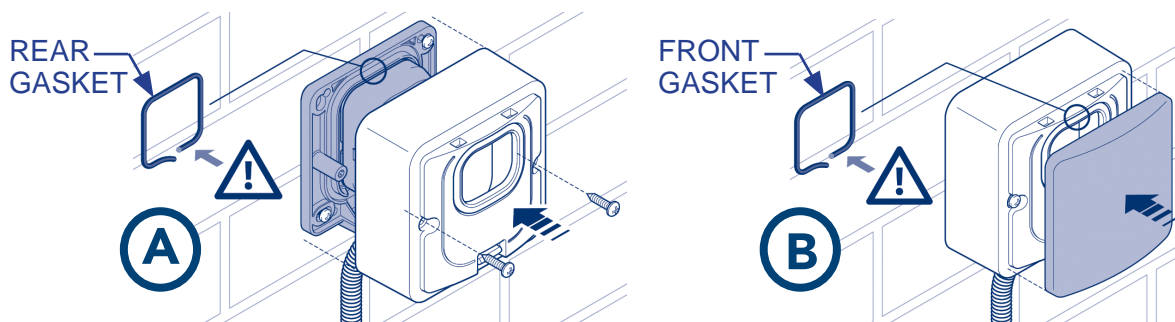

19

INSTALLING THE AUDIO ALARM

IMPORTANT!

The installer **MUST** connect the included audio alarm per these instructions. Installing the audio alarm is **REQUIRED** for UL325 compliance.

The audio alarm (siren) included in the kit must be connected to the 1050 control board to provide an audible alarm to indicate a hard shutdown of the system, which is triggered by two consecutive entrapment events. It is a piezoelectric device that can produce a minimum of 100 dB @ 1 foot from enclosure per UL code of continuous sound and is powered by 3-12 VDC. Install as follows:

1. The alarm has short leads but may be located inside the box without wiring in additional cable.

NOTICE

If using additional cable length for installation of alarm external to the control box, maximum wire/cable length is 1000 feet (308.4m).

2. Locate the alarm output connector per IMAGE 19.
3. Connect red wire to Pin 14 (Alarm), and black wire to Pin 15 (GND).
4. In the event of a hard shutdown, be sure to determine the problem before resetting the shutdown (pressing the RESET Button on the control board).

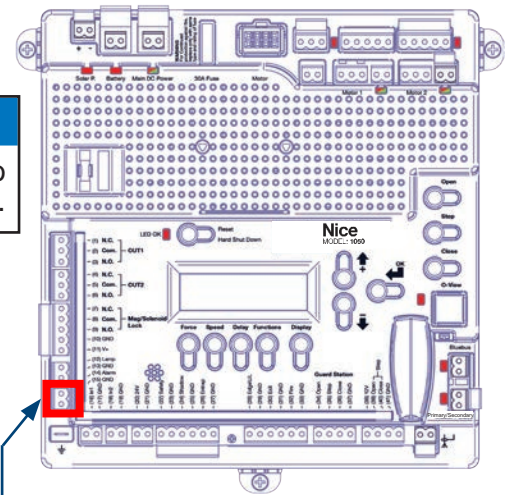

ALARM OUTPUT CONNECTOR

IMAGE 19: ALARM OUTPUT ON CONTROL BOARD

20

OXIBD/A RECEIVER INSTALLATION AND USE

If the OXIBD/A receiver is not already installed, plug into the 1050 controller as shown below.

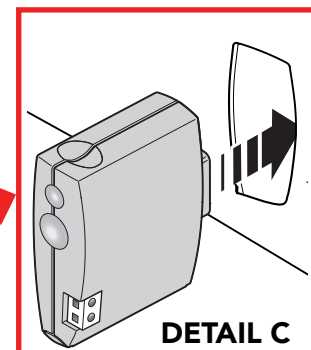
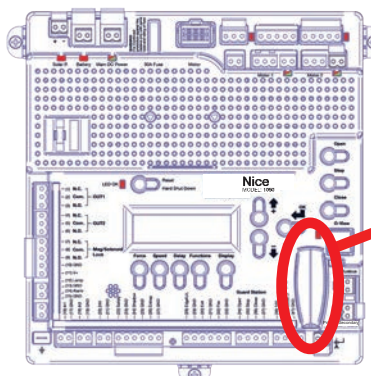

DETAIL C

IMAGE 20-1: OXIBD/A RECEIVER MODULE APPEARANCE AND LOCATION

OXIBD/A RECEIVER INSTALLATION AND USE (CONT.)

INSTALLING AN ANTENNA TO THE OXIBD/A RECEIVER

Install a single wire or coaxial cable antenna to the OXIBD/A as follows:

1. Ensure power to the control board is OFF.
2. Connect supplied antenna wire to terminal 1 of receiver (DETAIL A, below).
3. If installing the external antenna from the kit (P/N ABF/A), connect the 50Ω impedance coaxial cable directly to terminals 1 and 2 (DETAIL B, below). Lead = 1, Shield = 2.

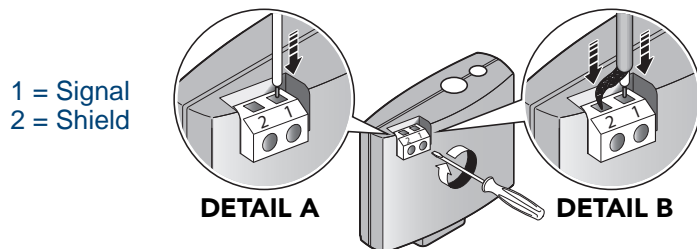

ASSIGNING A REMOTE CONTROL TO THE OXIBD/A RECEIVER

Procure a functioning two (or more) button Nice remote control (see image below) with a battery installed and assign it to the OXIBD/A receiver as follows:

1. Press and hold the program button on the top of the OXIBD/A receiver module (IMAGE 20-2, Left) until the green LED lights up on the top of the receiver, then release the button.
2. Within 10 seconds, press and hold any key on the Nice remote control until the LED in the Nice receiver blinks green 3 times, indicating that the remote control is programmed to control the receiver.
3. After the LED on the Nice receiver blinks green 3 times, another 10 second interval is started to program another Nice remote control if desired.
4. Repeat step 3 to program the additional Nice remote control (transmitter). Step 3 may be repeated as many times as necessary to program all available Nice remote controls.
5. Verify that the Nice remote control(s) can control the gate by pressing one or more buttons individually on the remote control(s).
6. If remotes do not function properly, refer to the FUNCTION/Radio Ch. Menu in SECTION 8 to assign the correct function to the radio channels.



**IMAGE 20-2: OXIBD/A RECEIVER (LEFT),
2-BUTTON REMOTE (MIDDLE) & 4-BUTTON REMOTE (RIGHT)**

21

DELETING SINGLE REMOTE CONTROL

A Nice remote control that has been programmed to control a Nice OXIBD/A receiver may be removed from the receiver memory without affecting other assigned remote controls as follows:

1. Press and hold the button on the side of the Nice receiver (on 1050 board) until the LED on the Nice receiver illuminates green and keep the button pressed. The LED will illuminate after approximately 4 seconds.
2. Press and hold any button on the Nice remote control until the LED on the Nice receiver blinks 5 green flashes
3. Release the button on the side of the Nice receiver.
4. It is recommended to verify that the non programmed Nice remote control no longer controls the gate.

22

DELETING ALL REMOTE CONTROLS

All programmed remote controls may be removed from the Nice OXIBD/A receiver memory as follows:

1. Press and hold the button on the side of the Nice OXIBD/A receiver module until the green LED on the receiver lights up and keep the button pressed.
2. Watch the LED and on the receiver and verify the following sequence in the LED:
 - a) Within 4 seconds after pressing the button (approx.) the green LED illuminates.
 - b) Within 8 seconds after pressing the button (approx.) the green LED turns off.
 - c) Within 12 seconds after pressing the button (approx.) the green LED starts flashing
3. Count the green LED flashes on the Nice receiver. On EXACTLY the 3rd flash, release the button on the Nice receiver.
4. It is recommended to test the Nice remote controls, if available, with Nice OXIBD/A plug-in receiver to verify that it no longer affects the gate controller.

SECTION 8: 1050 PROGRAMMING & CONTROLS

This section describes the navigation, menu, and programming controls for the 1050 control board. See FIGURE 8-1 (below) and TABLE 22-1 (next page) for identification of the controls used to navigate and select various options, and the following pages for descriptions and diagrams of menus and the options available for programming.

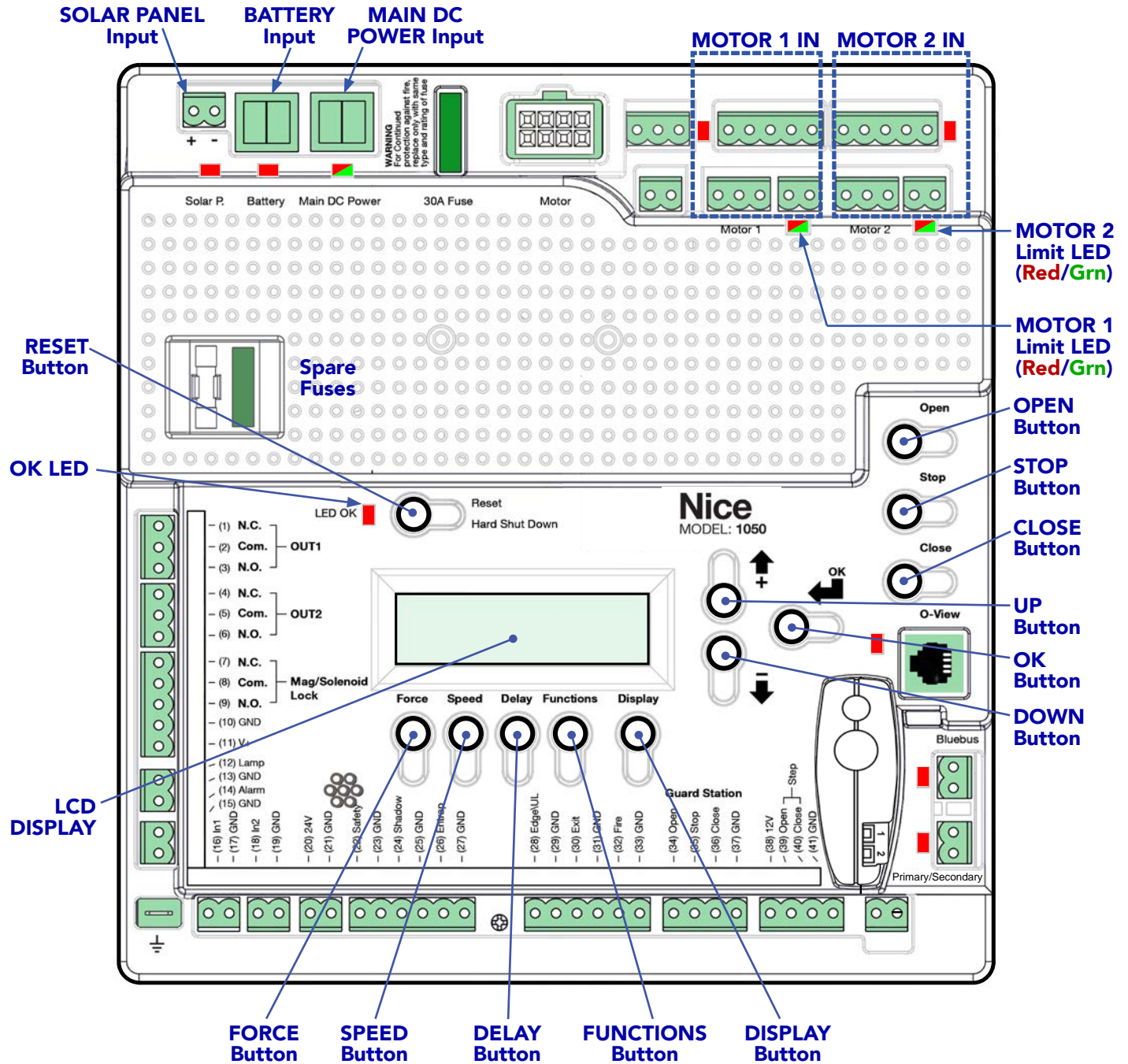

FIGURE 23: 1050 CONTROL BOARD COMPONENTS & CONTROLS

NOTICE

Use programming buttons only after understanding the manual and its relation to the programming sequences shown on the following pages. Care should be taken whenever changes are implemented to ensure proper functionality and safety.

23

CONTROL BOARD MENU NAVIGATION

Refer to IMAGE 22-1 on previous page for image of 1050 control board layout, LED indicators, and controls. Menus and parameters are accessed and selected by pressing the buttons on the 1050 control board as shown in Table 22-1:

TABLE 22-1: 1050 CONTROL BOARD BUTTON FUNCTIONS

BUTTON	FUNCTION
OPEN Button	Opens the gate.
STOP Button	Stops the gate, whether opening or closing.
CLOSE Button	Closes the gate.
UP Button	Used for navigating through menus, options, and values.
DOWN Button	Used for navigating through menus, options, and values.
OK Button	Selects the current menu, option, or value shown in the display.
RESET Button	Resets a hard shutdown.







Navigation buttons are used as follows:

1. Press desired option button. Option menu name appears in top half of display. Sub-option names and parameter values appear in the lower half of display.
2. Press UP and DOWN buttons to navigate between options or values.
3. Press OK to select options to change or to accept selected values.
4. Each menu features an ESC selection for exiting the menu.

NOTICE

The following pages illustrate and map the menu selection options in the 1050 control board.

1050 CONTROL BOARD MENU FLOW CHART LEGEND

SYMBOL	MEANING	SYMBOL	MEANING
	Generic 1050 Button		LCD Display (default values in red)
	Push OK Button		Menu Flow Direction
	Push UP Button		Use UP & DOWN arrows to select
	Push DOWN Button		

FORCE Button

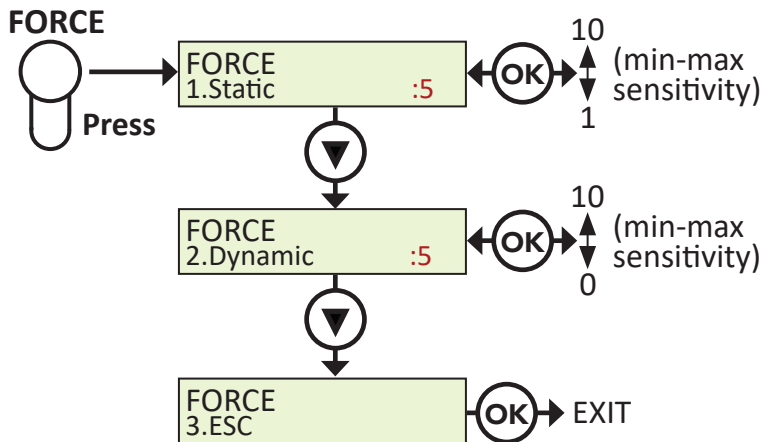

FORCE BUTTON MENU:

Amount of force needed to cause the gate to stop and reverse when hitting an obstacle.

- **STATIC:** Set sensitivity to constant force on a scale of 1 to 10 (1 being the most sensitive).
- **DYNAMIC:** Set sensitivity of sudden impact force to the moving gate on a scale of 1 to 10 (1 being most sensitive). 0 = OFF.
- **EXIT:** Exits the FORCE menu.

SPEED Button

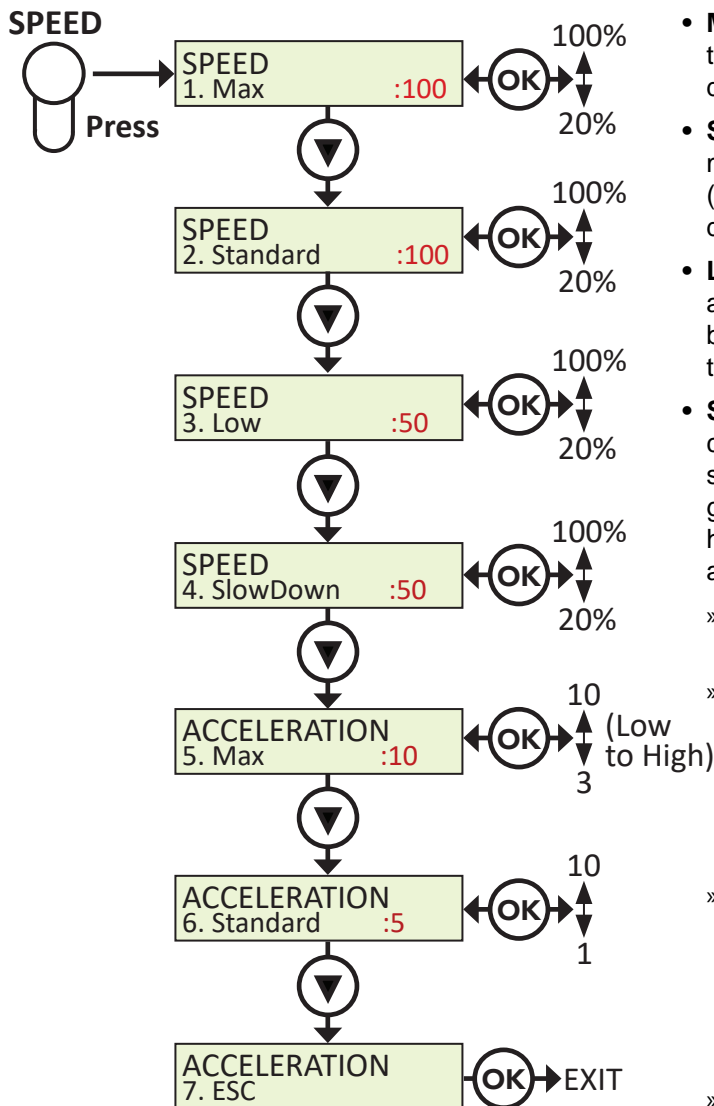

SPEED BUTTON MENU:

Sets the speed of the gate under various conditions.

- **MAX:** Sets limit of max allowed gate speed on scale of 20% to 100% (20% is lowest setting). It is recommended to set to default of 100.
- **STANDARD:** Sets limit of the gate speed during normal movement (not soft start/stop) on scale of 20% to 100% (20% being the lowest setting). It is recommended to set to default of 100.
- **LOW:** Sets limit of the gate speed while in LEARNING mode and when moving in SLOW, on scale of 20% to 100% (20% being the lowest setting). Recommended not to be set lower than 50. Default setting depends upon learning parameters
- **SLOWDOWN:** Set gate speed when approaching the open or close limits on scale of 20% to 100% (20% being the lowest setting). Recommended not to set lower than 50% for slide gates. The lower this setting the less power the operator will have when approaching the limit. Setting too low could cause a stall condition prior to open/close limit.
 - » **ACCELERATION:** Adjusts the rate of acceleration/ deceleration when the motor starts and stops moving:
 - » **MAX:** Sets the limit of gate acceleration and deceleration when reversing the gate after an obstacle has been detected by the UL/Edge or current sense feature (Force). Settings from 3 to 10, with 10 being the highest rate of gate acceleration.
 - » **STANDARD:** Sets the limit of the gate acceleration and deceleration in normal operation. Settings from 1 to 10, with 10 being the highest rate of gate acceleration.
- * **TO PREVENT DAMAGE TO THE GATE OR THE CONTROLLER USE LOWER ACCELERATION SETTINGS FOR HEAVIER GATES.
- » **ESC:** Exit the SPEED / ACCELERATION menus.

DELAY Button

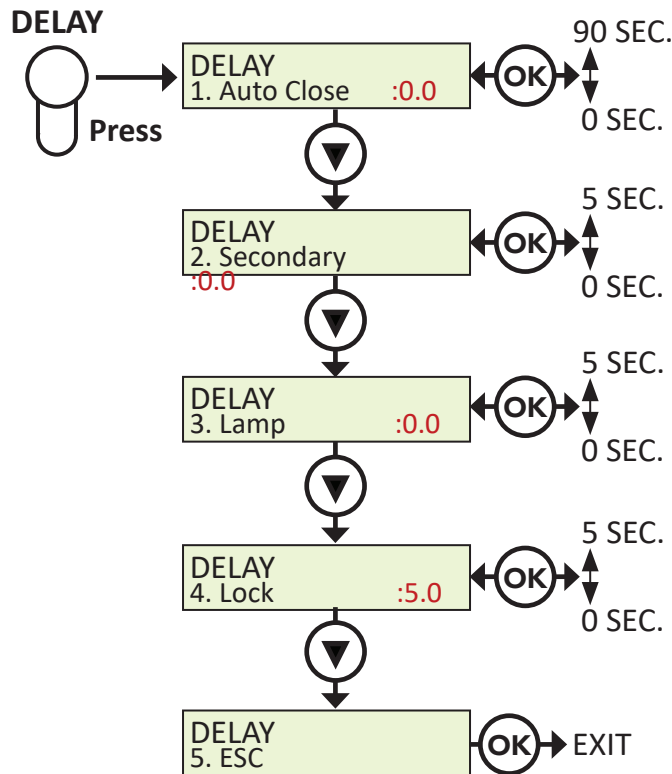

DELAY BUTTON MENU:

- **AUTO CLOSE:** Sets the time before the gate closes automatically from the fully open position. Settings from 0 (off) to 90 seconds. Setting this to 0 will disable the auto close timer.
- **SECONDARY:** Enables overlapping dual gates to dovetail smoothly by creating a momentary delay for Secondary operator when opening and Primary when closing. Settings from 0-5 seconds with increments of 0.5.

Example: If 03 is selected, in the OPEN direction the Secondary operator will begin to OPEN 3 seconds after the Primary. In the CLOSE direction the Primary operator will begin to CLOSE 3 seconds after the Secondary.

NOTICE

The Remote Primary/Secondary setting must be turned on for 24V commercial operators in the Advanced Settings menu and each operator defined as Primary or Secondary. For 12V residential operators the Primary is Motor 1 by default but can be changed in the Advance Settings menu.

- **LAMP/STROBE:** Sets the amount of time the Lamp accessory output is activated prior to gate movement. Settings from 0 to 5 seconds with a step of 0.5 seconds.
- **LOCK:** Sets the amount of time the Magnetic Lock accessory output is activated to disable the lock when opening the gate. Settings from 0 to 5 seconds with a step of 0.5 seconds.
- **ESC:** Exit the DELAY menu.

FUNCTION Button > Learn

GATE WEIGHT TABLE	
Light	Results in quicker acceleration/ deceleration, lower (more sensitive) FORCE settings, and higher SLOWDOWN speed.
Medium	Recommended for best reliability and functionality on all gate sizes and weights.
Heavy	Results in slower acceleration/ deceleration, higher (less sensitive) FORCE settings, and lower SLOWDOWN speeds.

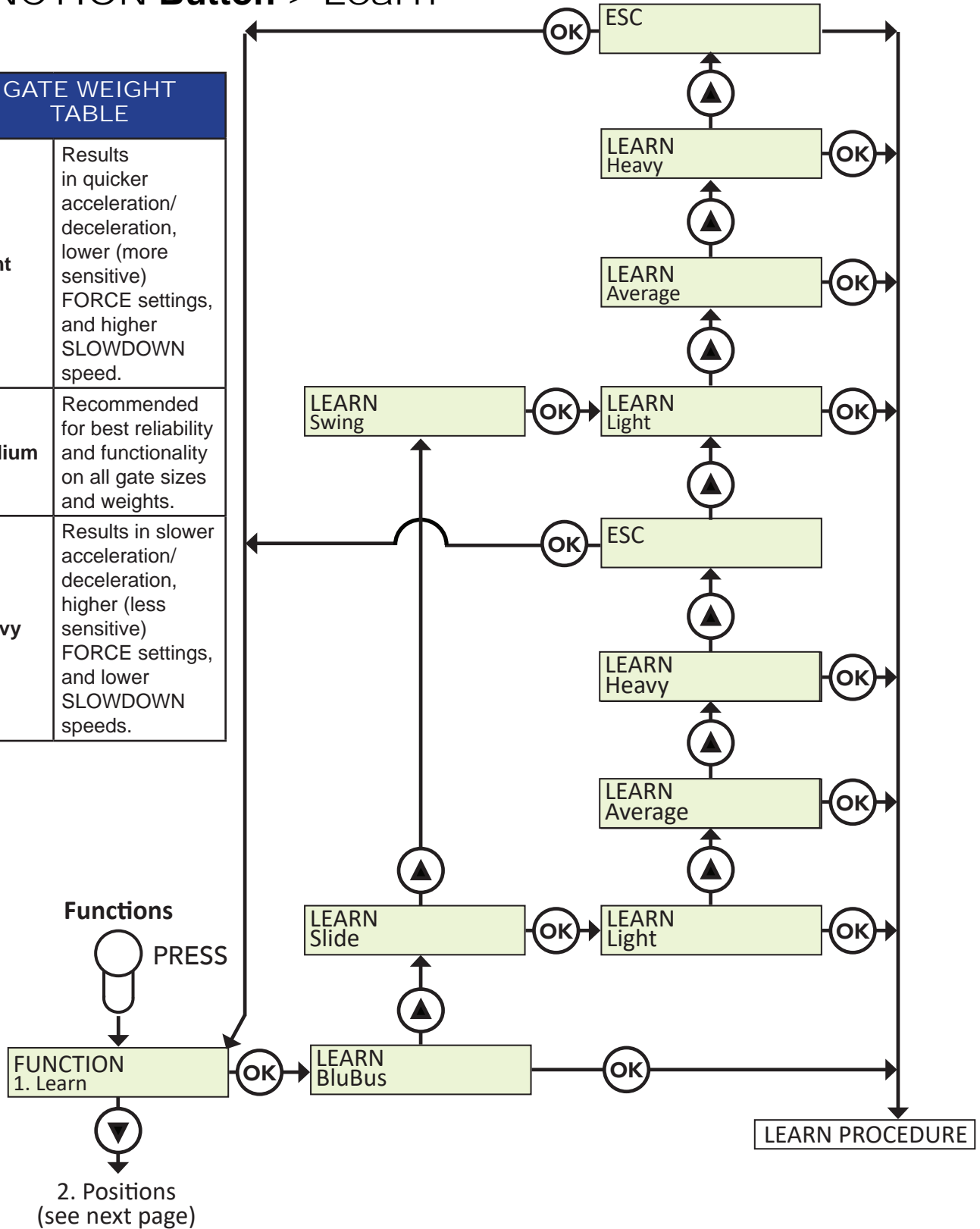

FUNCTION Button > Positions

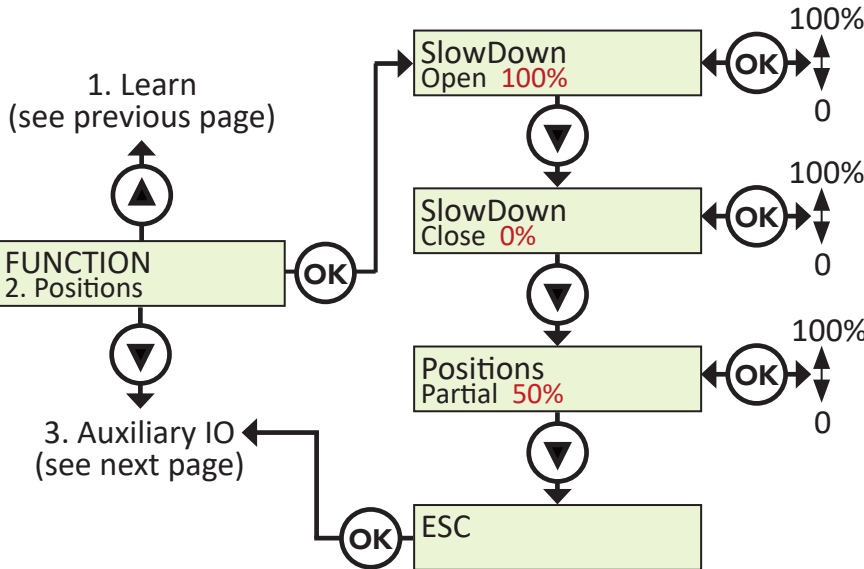

FUNCTIONS > POSITIONS MENU:

Sets points in the gate open, close, and partial cycles at which deceleration occurs.

- **SLOW DOWN - OPEN:** Sets the point in the % of gate opening when the gate begins deceleration to the fully open position.
- **SLOW DOWN - CLOSE:** Sets the % of gate opening when the gate begins deceleration to the fully close position.
- **POSITIONS - PARTIAL:** Sets the point in the % of gate opening where the gate will stop when given a PARTIAL command.

FUNCTION Button > Auxiliary IO

NOTICE
See parameter descriptions on next page.

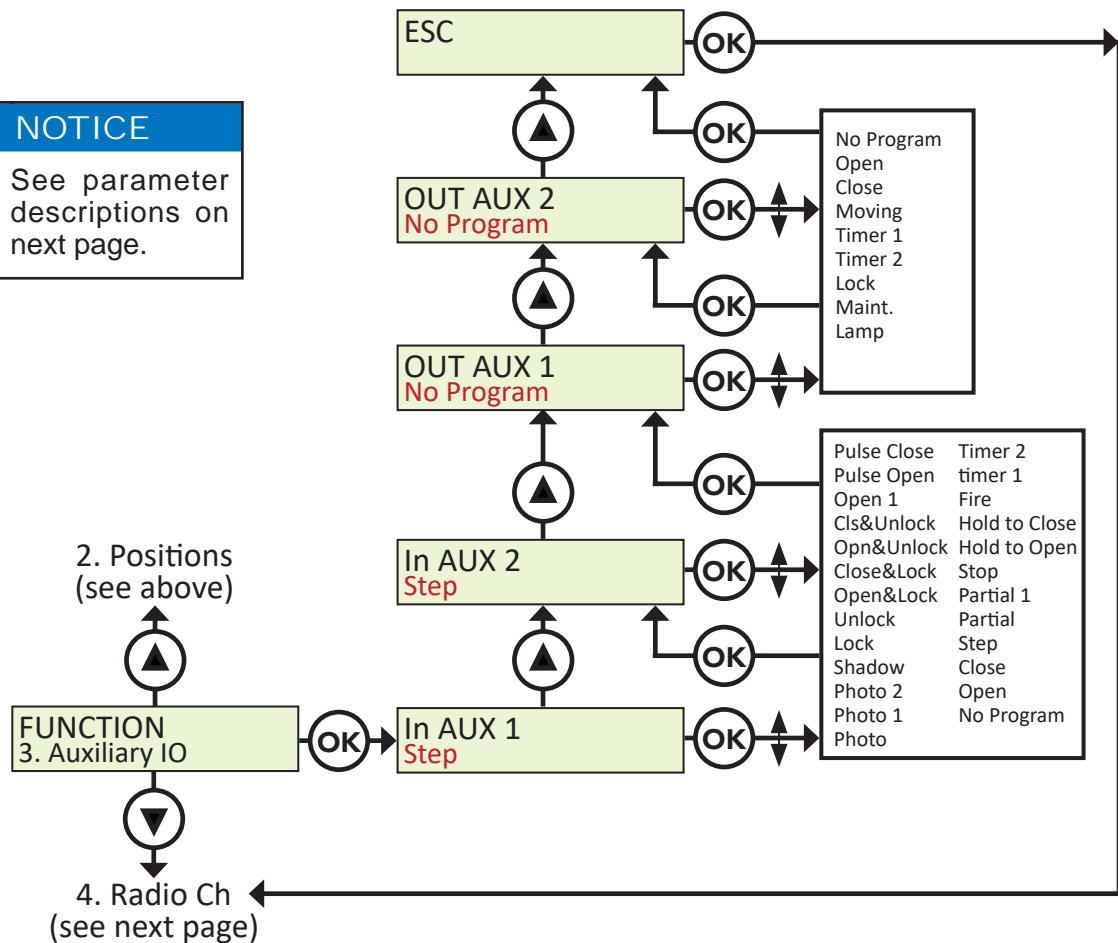

FUNCTION **Button** > Auxiliary IO (Cont.)

FUNCTION>AUXILIARY INPUTS MENU:

The auxiliary inputs IN1(16) and IN2 (18) can be programmed with one of the following options:

- **NO PROGRAM:** No function used.
- **OPEN:** Opens the gate.
- **CLOSE:** Closes the gate.
- **STEP:** Cycling step (Open-Stop-Close-Stop).
- **PARTIAL:** Partial opening.
- **PARTIAL 1:** Partial opening 1 (open one leaf in dual gate applications).
- **STOP:** Stop the gate and auto-closing.
- **HOLD TO OPEN:** Input must be maintain active for opening.
- **HOLD TO CLOSE:** Input must be maintain active for Closing.
- **FIRE:** Reset hard shut down and open the gate.
- **TIMER 1:** Start count down TIMER1.
- **TIMER 2:** Start count down TIMER2.
- **PHOTO:** Photocell PHOTO input: reverse to opening when closing.
- **PHOTO 1:** Photocell PHOTO1 input: Stop gate when activated.
- **PHOTO 2:** Photocell PHOTO2 input: reverse to closing when opening.
- **SHADOW:** Loop input: Prevent closing gate when completely open.
- **LOCK:** Lock system from other command (only STEP H overrides the lock).
- **UNLOCK:** Unlock the system if locked.
- **OPEN&LOCK:** Open the gate and inhibit further commands (except STEP H).
- **CLOSE&LOCK:** Close the gate and inhibit further commands (except STEP H).
- **OPEN&UNLOCK:** Open the gate and un-inhibit further commands.
- **CLOSE&UNLOCK:** Close the gate and un-inhibit further commands.
- **STEP H:** Command high priority Step cycling (open-stop-close-stop).
- **OPEN 1:** Reopens a gate that has drifted off its open limit.
- **PULSE OPEN:** Connect a monitored external entrapment sensor with a 300 Hz pulse output that protects the open direction of travel.
- **PULSE CLOSE:** Connect a monitored 300 Hz external entrapment sensor with a 300 Hz pulse output that protects the close direction of travel.

FUNCTION>AUXILIARY OUTPUTS MENU:

Auxiliary outputs OUT1 (1,2,3,) and OUT2 (4,5,6,) can be programmed with one of these options.

- **NO PROGRAM:** Output not used.
- **OPEN:** Output is activated when gate is open.
- **CLOSE:** Output is activated when gate is closed.
- **MOVING:** Output is activated when gate is moving.
- **TIMER 1:** Output is activated when TIMER1 is counting down.
- **TIMER 2:** Output is activated when TIMER2 is counting down.
- **LOCK:** Output is activated when gate is locked open or closed.
- **MAINTENANCE:** Output is activated when maintenance count exceeded (set in Display>Service in increments of 1000 gate cycles). Can be set to trigger alarm or light to signal that maintenance should be performed).
- **LAMP:** Output is activated when lamp (conn. 12/13) is connected and on.

FUNCTION **Button** > Radio Ch.

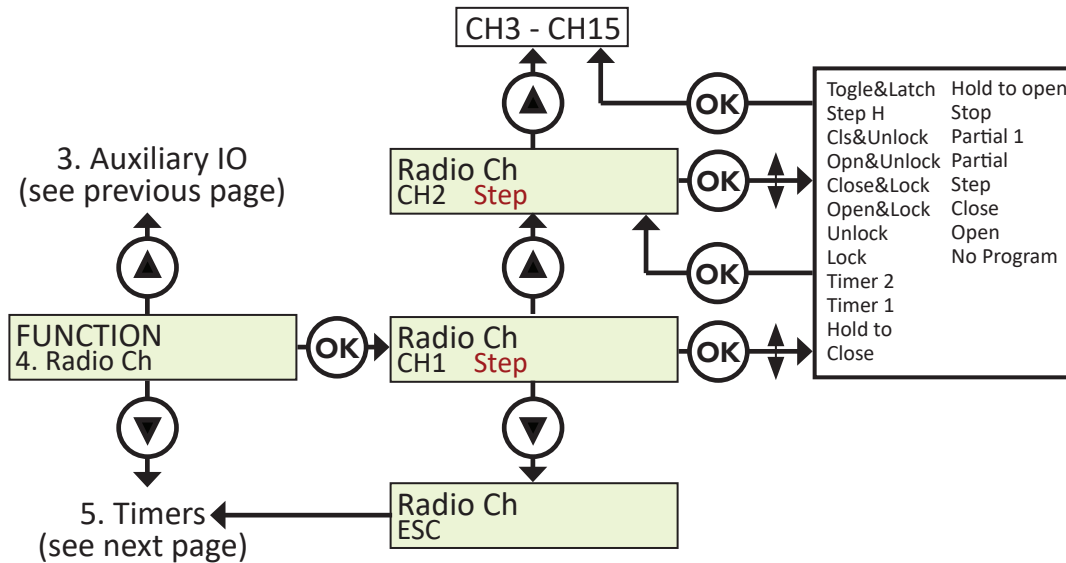

FUNCTION>RADIO CHANNEL MENU:

For the Plug-in On board Receiver, 15 radio channels may be programmed with one of the following options:

- No Program
- Open (Default Ch. 2)
- Close (Default Ch. 3)
- Step (Default Ch. 1)
- Partial (Default Ch. 4)
- Partial 1
- Stop
- Hold To Open
- Hold To Close
- Timer 1
- Timer 2
- Photo
- Lock
- Unlock
- Open And Lock
- Close And Lock
- Open And Unlock
- Close And Unlock
- Step H
- Togle & Latch

FUNCTION Button / Events

NOTICE

See INSTRUCTIONS 23 and 24 (next page) for specific instructions for programming and suspending events.

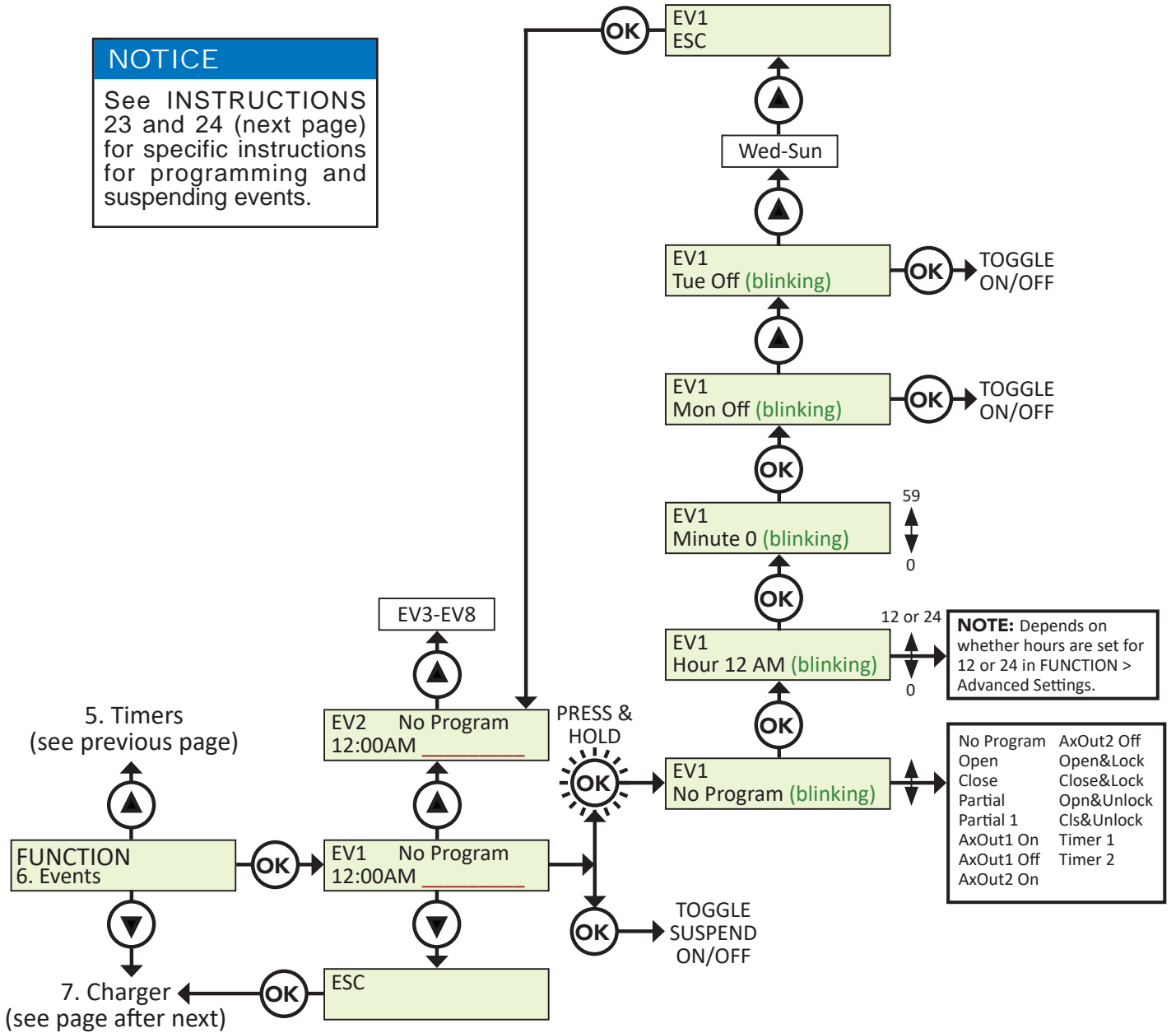

FUNCTION>EVENTS MENU:

Up to eight weekly events (EV1 through EV8) can be programmed and stored. Each event can be programmed to trigger at a specific time and can be assigned to any combination of days of the week (Monday through Sunday).

- No Program
- Open
- Close
- Partial
- Partial 1
- AxOut1 On
- AxOut1 Off
- AxOut2 On
- AxOut2 Off
- Open&Lock
- Close&Lock
- Opn&Unlock
- Cls&Unlock
- Timer 1
- Timer 2

23

1050 EVENT PROGRAMMING INSTRUCTIONS

To PROGRAM weekly events EV1 through EV8, perform the following steps:

1. Ensure time and date are set correctly. See Function/Display Menu for how to set time/date.
2. Press FUNCTION > Events.
3. Press and hold OK to display EV1 (event program will blink).
4. Press UP or DOWN to toggle between events, then press OK to make a selection. The display changes to hours.
5. Press UP or DOWN to toggle between hours, then press OK to make a selection. The display changes to minutes.
6. Press UP or DOWN to toggle between minutes, then press OK to make a selection. The display changes to individual days of the week.
7. Press UP or DOWN to toggle between days of the week. Press OK to toggle between ON and OFF for each day of the week. Continue moving up through the days of the week until ESC is displayed. Press OK to advance to the next event.
8. Repeat step 2 through 6 for event EV2 through EV8.

24

1050 SUSPEND EVENT INSTRUCTIONS

To TEMPORARILY SUSPEND one or more weekly events (EV1 through EV8), perform the following steps:

1. Press FUNCTION > Events.
2. Press OK quickly to display EV1 active days.
3. Press OK quickly again to display "Suspend". Event EV1 is now suspended and will not run until re-enabled.
4. Press UP or DOWN to toggle through the events EV1 – EV8 and repeat steps 2 through 3 to suspend or enable other weekly events.

FUNCTION **Button** / Charger

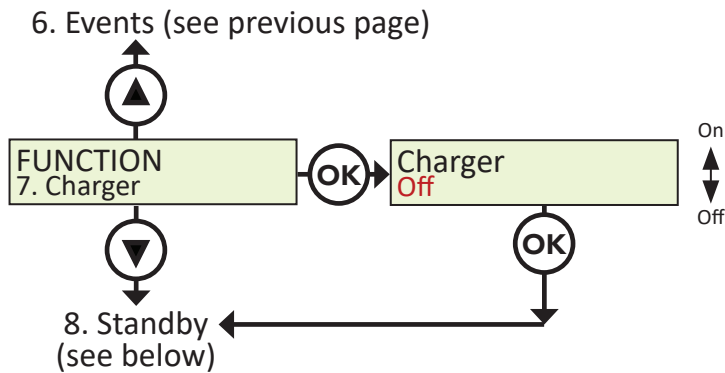

FUNCTION>CHARGER MENU:

Built-in battery charger is for use with backup battery. Charger may be manually programmed for customized charge settings or set to “Auto” for battery charging profile that automatically compensates for temperature and current during charging.

IMPORTANT!

ALL settings must be verified by pressing OK or the internal charging system will be turned OFF.

FUNCTION **Button** / Standby

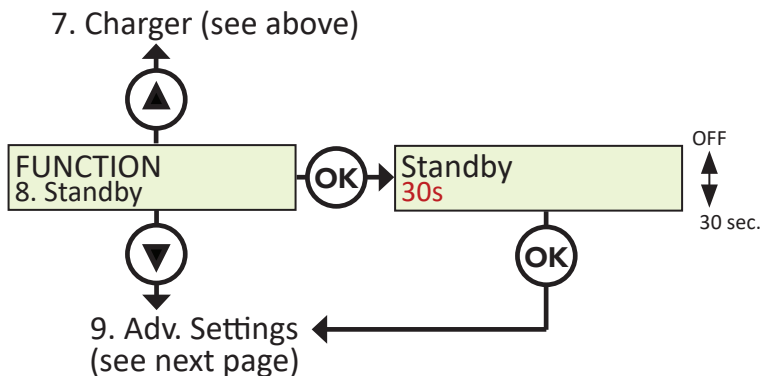

NOTICE

30 seconds is the recommended setting.

FUNCTION>STANDBY MENU:

Programs timeout of low power standby mode for gate operator. The Standby setting may be set to either 30 seconds or OFF. During low power standby there is no data displayed on the gate operator LCD and it consumes a minimum amount of power to extend the life of the backup battery. Most of the outputs, including output power at #20 (24v) and #38 (12V), are switched off during Standby Mode and the OK LED blinks to indicate standby status. Output #11 (V+) provides power during Standby Mode.

FUNCTION Button / Adv. Settings

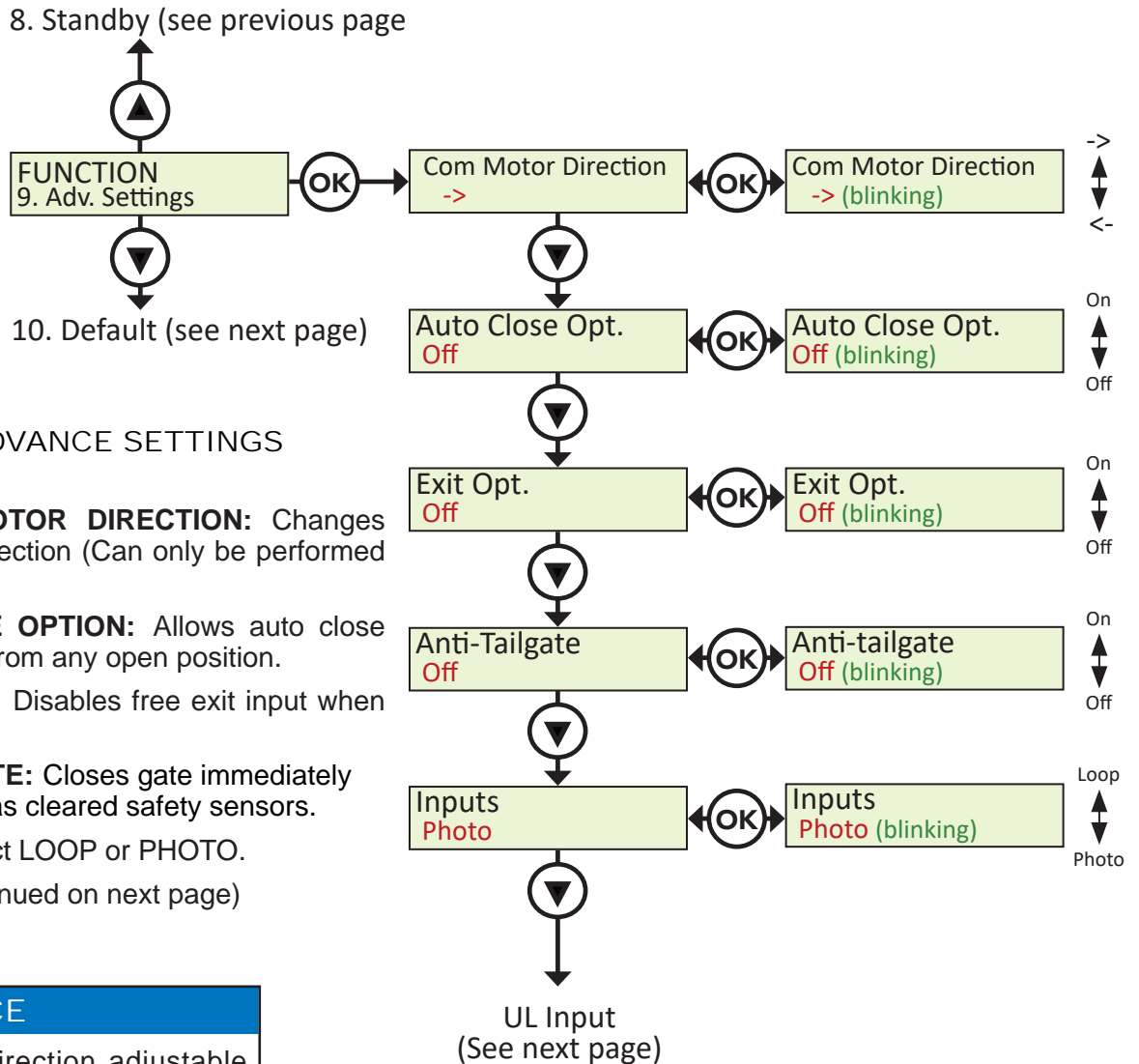

FUNCTION>ADVANCE SETTINGS
MENU:

- **COMMON MOTOR DIRECTION:** Changes main motor direction (Can only be performed in learn mode).
- **AUTO CLOSE OPTION:** Allows auto close timer to close from any open position.
- **EXIT OPTION:** Disables free exit input when partially open.
- **ANTI-TAILGATE:** Closes gate immediately after vehicle has cleared safety sensors.
- **INPUTS:** Select LOOP or PHOTO.
(Continued on next page)

NOTICE

Motor direction adjustable only in Learn Mode.

FUNCTION Button / Adv. Settings (Cont.)

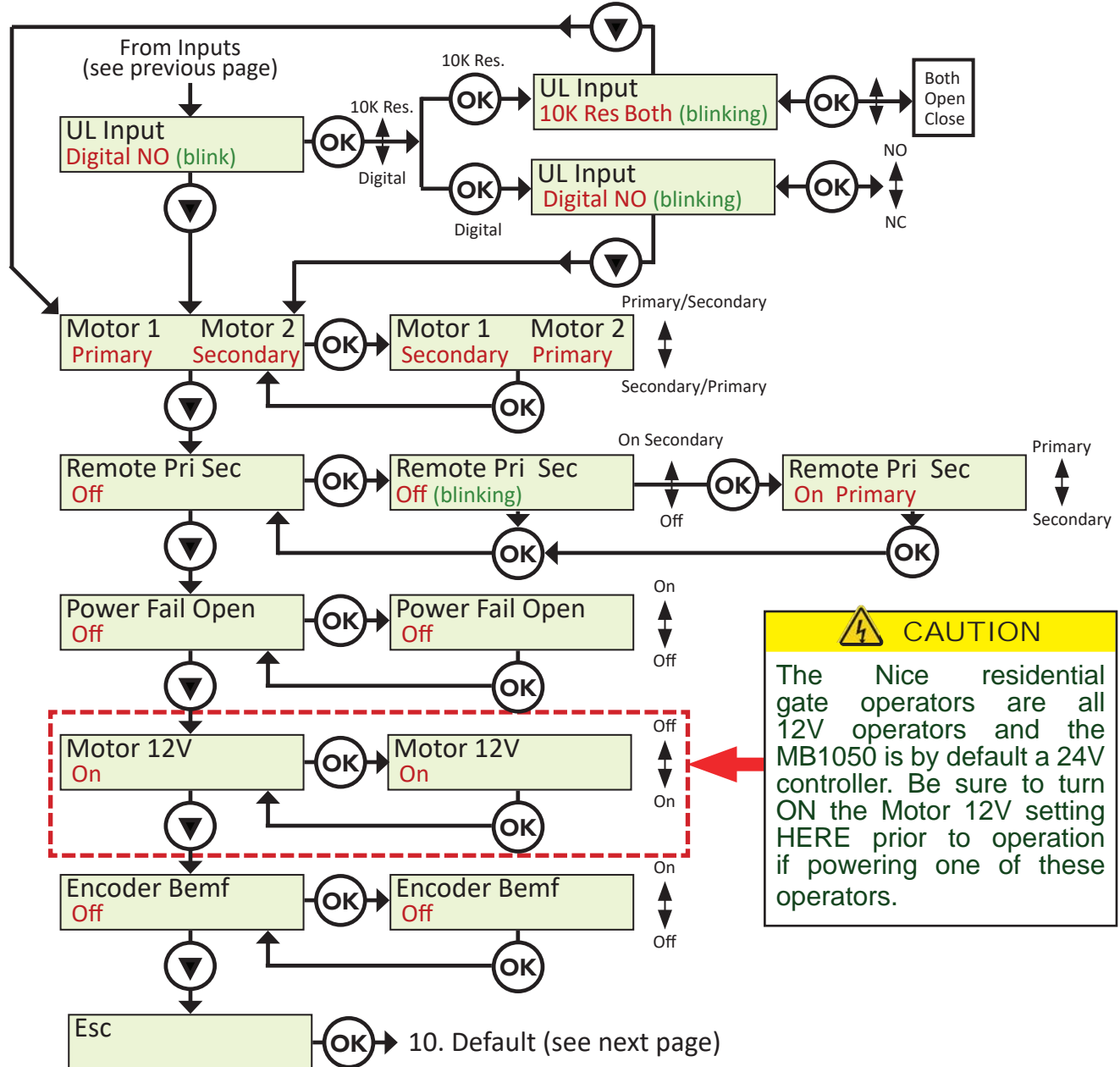

FUNCTION>ADVANCE SETTINGS MENU (Cont.):

- **UL INPUT:** For analog, select both, open, or close. For digital, select NC (normally closed) or NO (normally open).

NOTICE

When set to 10K RES OPEN, CLOSE, or 10K RES BOTH, input must have an 8.2k-10k Ohm terminated external entrapment sensor installed. 10K RES BOTH only available for Swing Gates.

- **SELECT PRIMARY / SECONDARY:** Motor1 or Motor2
- **ACTIVATE LINK FOR REMOTE PRIMARY/SECONDARY:** Enables control of an additional gate operator board.
- **POWER FAIL OPEN:** Opens gate automatically on battery backup power if main AC power input loss is detected.
- **MOTOR 12V:** Forces motor control voltage to +12 VDC even if the supply voltage varies +9.5 VDC up to +35 VDC)
- **SET VIRTUAL ENCODER:** For motors without built-in encoders.

FUNCTION Button / Defaults

9. Adv. Settings (see previous page)

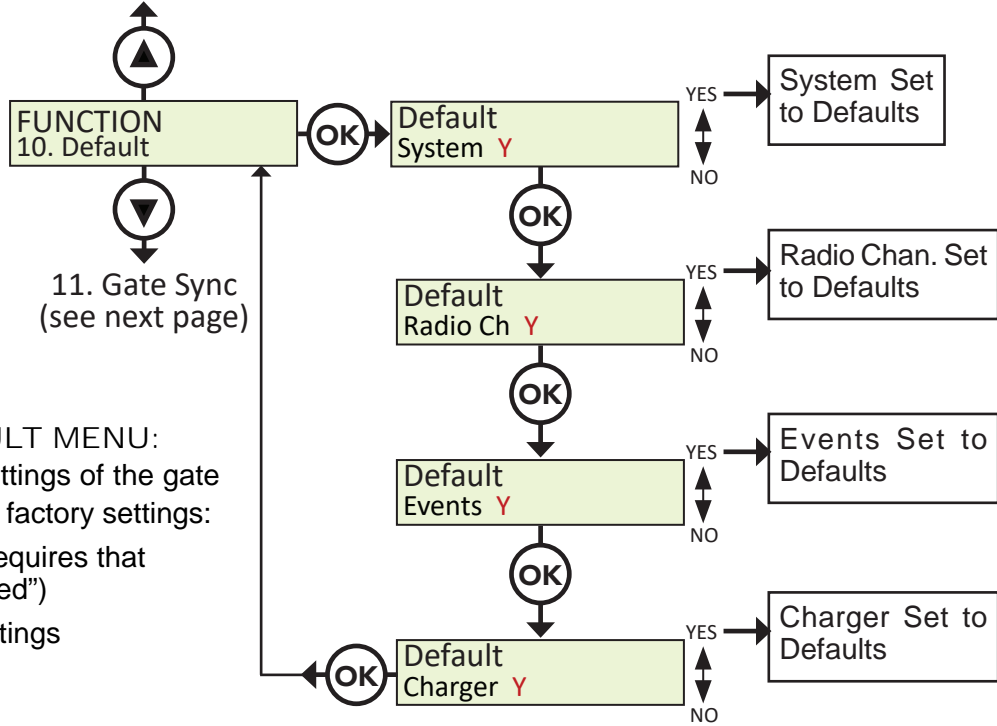

FUNCTION>DEFAULT MENU:
Returns some or all settings of the gate operator to the original factory settings:

- System Settings (requires that system be “relearned”)
- Radio Channel Settings
- Event Settings
- Charger Settings

FUNCTION Button / Gate Sync

GATE SYNC MENU:

In a dual gate system, the actuator nearest the control box (connected to Motor 1 inputs) has a substantially shorter cable than that connected to Motor 2 inputs. This may introduce a noticeable voltage drop and reduction in speed of Motor 2 actuator compared to the Motor 1 actuator. When this setting is ON, the control board attempts to synchronize the run time of both actuators.

10. Defaults (see above)

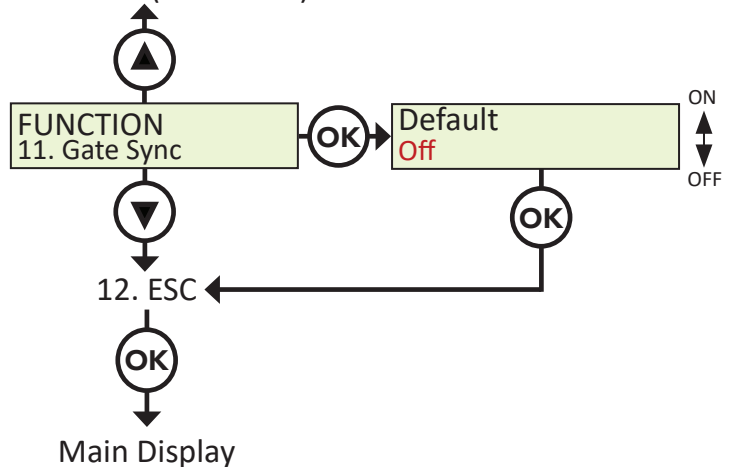

DISPLAY Button: For selecting certain information for viewing in the LCD display.

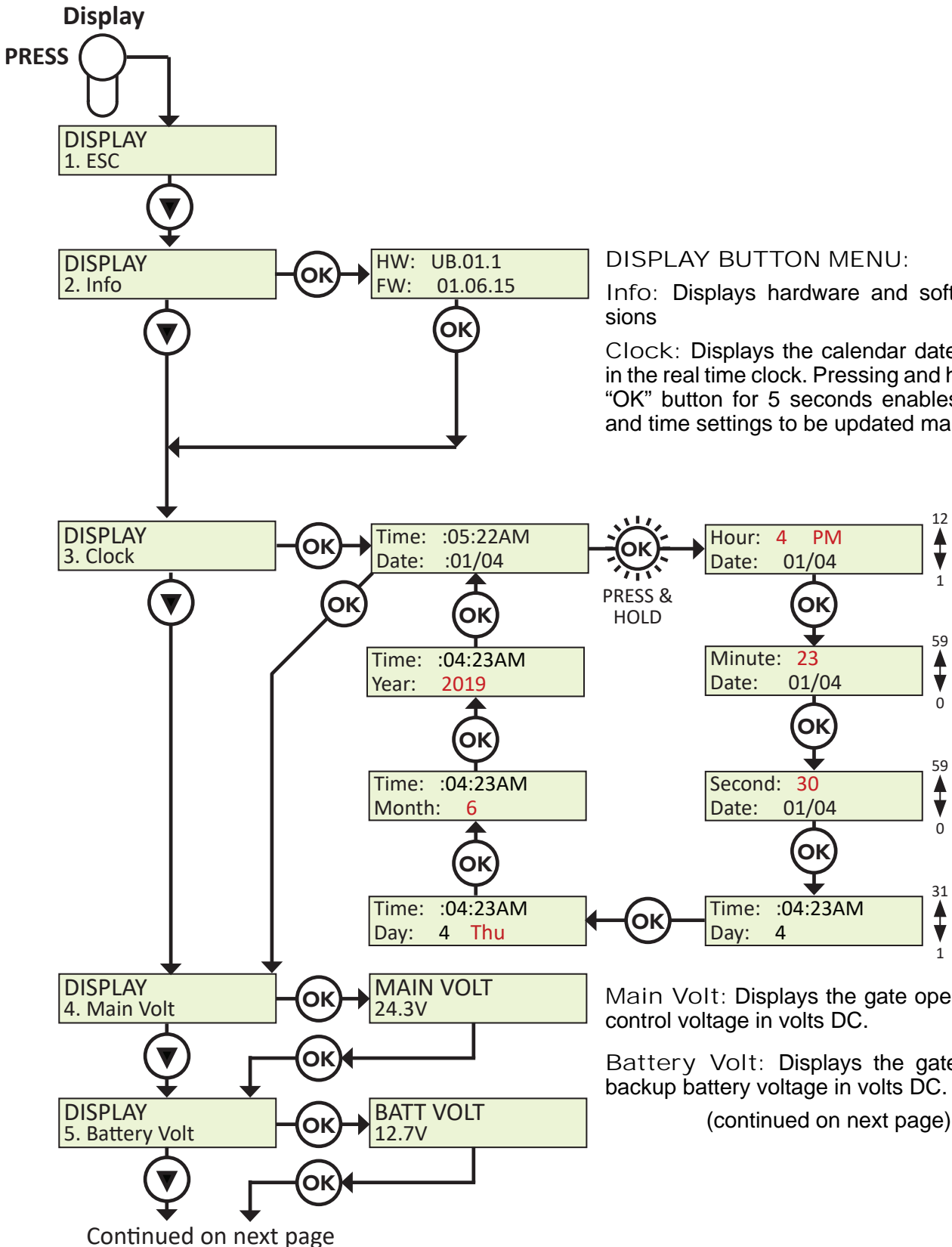

Continued on next page

DISPLAY Button (Cont.):

Continued from last page

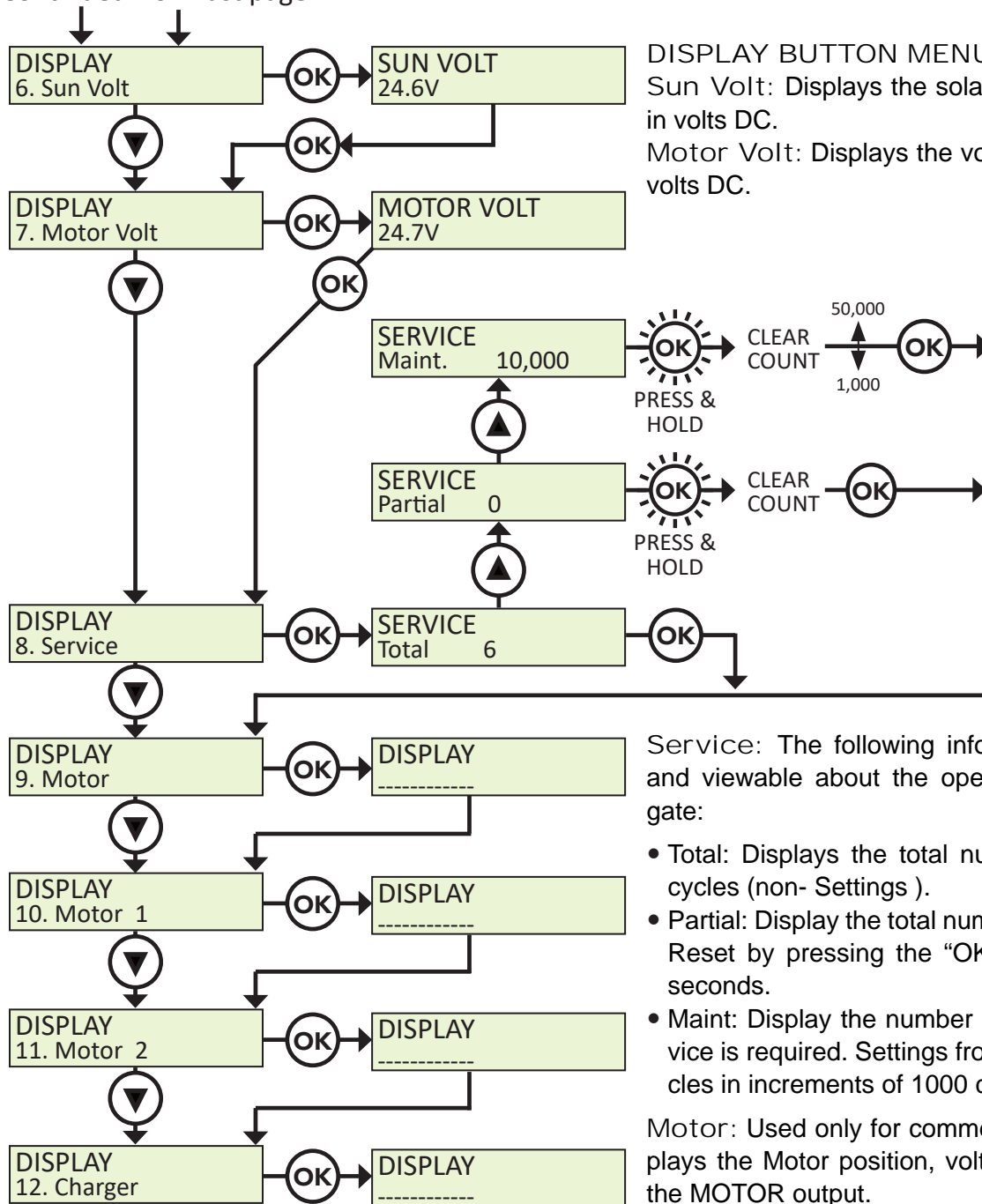

DISPLAY BUTTON MENU (CONT.):

Sun Volt: Displays the solar panel input voltage in volts DC.
 Motor Volt: Displays the voltage at the motor in volts DC.

Service: The following information is recorded and viewable about the operating history of the gate:

- Total: Displays the total number of open-close cycles (non- Settings).
- Partial: Display the total number of partial cycles. Reset by pressing the “OK” button for several seconds.
- Maint: Display the number of cycles before service is required. Settings from 1000 to 50000 cycles in increments of 1000 cycles.

Motor: Used only for commercial operators. Displays the Motor position, voltage, and current for the MOTOR output.

Motor 1: Used to view position, voltage, and current for Motor1 (primary actuator).

Motor 2: Used to view position, voltage, and current for Motor2 (secondary actuator).

Charger: Displays the battery charger voltage and current.

8.1 CONTROL BOARD ERROR MESSAGES & TROUBLESHOOTING

CONTROL BOARD ERROR MESSAGES AND TROUBLESHOOTING		
DISPLAY	REASON	POSSIBLE CAUSE(S)
Dynamic M1	Actuator connected to Motor 1 has a brief current spike and tripped Type A sensor.	Check for obstruction in gate path or degraded gate hardware.
Dynamic M2	Actuator connected to Motor 2 has a brief current spike and tripped Type A sensor.	Check for obstruction in gate path or degraded gate hardware.
Static M1	Actuator connected to Motor 1 has an extended current spike and tripped Type A sensor.	Check for obstruction in gate path or degraded gate hardware.
Static M2	Actuator connected to Motor 2 has an extended current spike and tripped Type A sensor.	Check for obstruction in gate path or degraded gate hardware.
Input UL/Edge	UL/Edge input is tripped while gate is running. Appears if IN1 or IN2 input is tripped if configured as a pulsed, external sensor input.	Ensure photo eyes are aligned, edges are not tripped, and all inputs are programmed correctly.
Input STOP!	STOP input is not connect to GND.	Ensure jumper wire is being used and check external stop button wiring.
Photo Test FAIL!	BlueBus monitored sensor check fails.	Verify photo eye is connected, aligned, and internal jumpers are set correctly.
Device Error	Position sensor is not being correctly detected by the board or if there is an active input on the board preventing the learn process.	Ensure Motor 1 and Motor 2 position sensors are connected correctly for the type of actuator being used. Also make sure there are no active inputs.
Gate Opened	Appears during Learn Mode if Open Limit is active.	Change gate to mid-travel and restart the learn process.
BlueBus or Input - Activated	Appears when active BlueBus or other external entrapment sensor input is preventing gate motion.	Ensure all sensors are connected correctly and properly aligned. Ensure all inputs are programmed correctly.
Hard Shut Down	Appears when Dynamic and/or Static sensors have two consecutive trips.	Press the Reset/Hard Shut Down button to clear the trip and re-enable gate operation.
Overload	Appears when Motor 1 or Motor 2 over-current.	Ensure motors are connected properly and there is no obstruction to gate movement.
Slide Requires Min 2 Sensors!	Appears when there are not at least two external entrapment sensors programmed and installed on a Slide Gate.	Ensure all sensors are connected correctly and functional. Does not appear on Swing gates.
BlueBus Error!	Appears when previously learned numbers and type of BlueBus sensors change.	Correct wiring/number of sensors and redo the learn procedure for the operator.
Scanning BluBus - Prs Disp to Cncl	Appears when initial BlueBus learn procedure is in process.	Pressing the Display button will postpone the scan and remain in Learn Mode.
Min 1 Sensor for Swing Gate!	Appears when there is no external entrapment sensors programmed and installed on a SWING GATE system.	To satisfy UL requirements, an external entrapment sensor should be connected to the swing gate control board and appropriately programmed.

SECTION 9: 1050 ACCESSORY CONNECTIONS

This section describes the accessory functions, connections, and wiring for the 1050 control board. See IMAGE 9-1(below) for a visual representation of all the accessory inputs and outputs, and the following pages for a description of I/O functions and pin designations.

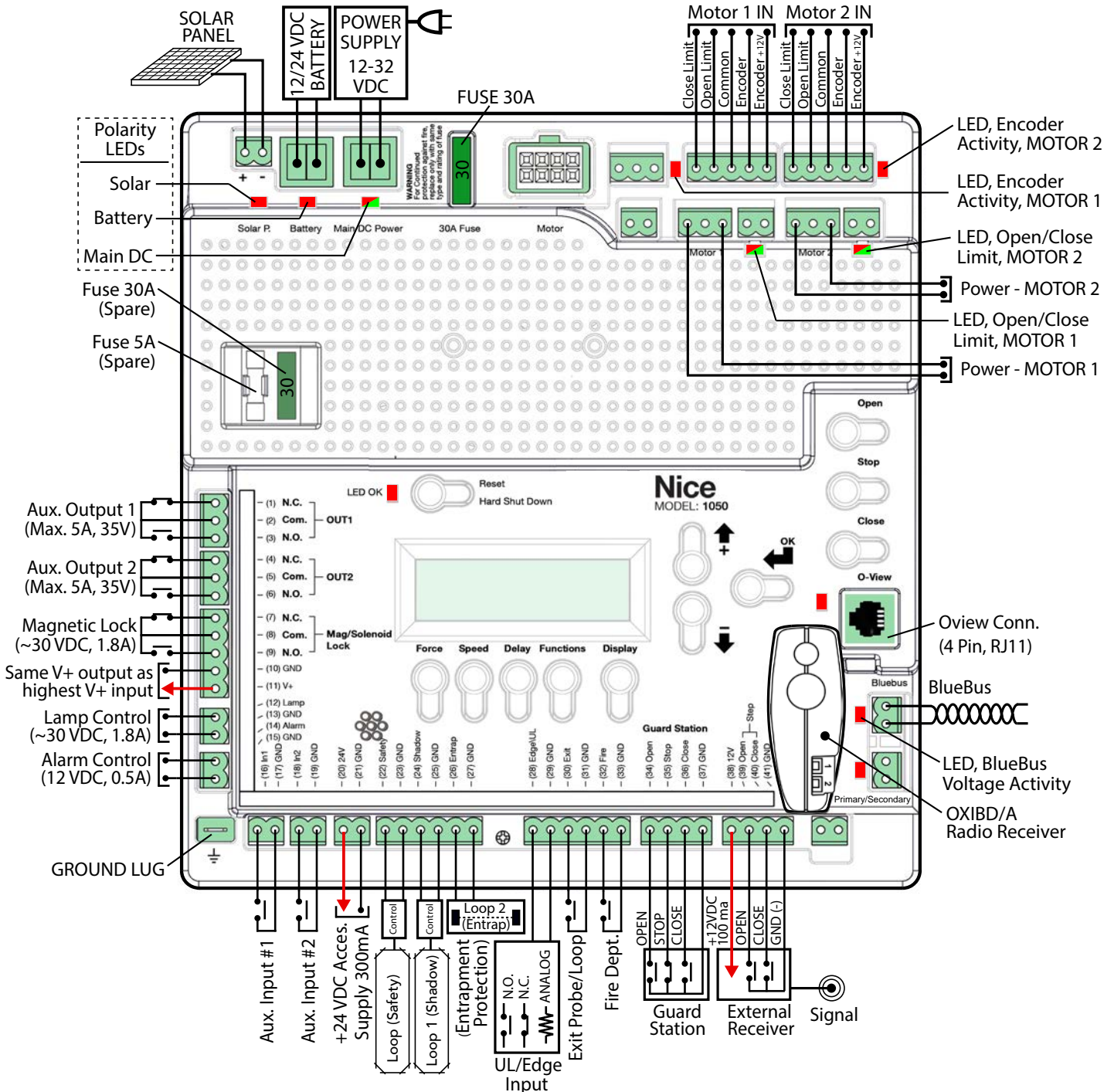

FIGURE 9-1: 1050 CONTROL BOARD ACCESSORY CONNECTIONS

9.1 OUTPUT CONNECTORS

OUT 1 / OUT 2 (1-6):

Individual, isolated relays provide dry contacts for switching accessories based on programming of the “Auxiliary IO” function. These outputs are programmed in the “FUNCTION / Auxiliary I/O” menu.

OUT 1

PIN 1 = N.C. (Normally Closed)
 PIN 2 = Com (Common)
 PIN 3 = N.O. (Normally Open)

OUT 2

PIN 4 = N.C. (Normally Closed)
 PIN 5 = Com (Common)
 PIN 6 = N.O. (Normally Open)

MAGNETIC LOCK (7-11):

- Provides fused power (1.85A max) and isolated relay dry contacts for electrically powered and maintained magnetic locks.
- This connection is used to install the magnetic lock. Consult lock manual for specifics on installation and wiring.
- The output time for magnetic lock activation/deactivation may be adjusted from 0 to 5 seconds.
- When the control board is in standby mode, power is still present at terminals 10 and 11. If standby mode is used (especially in a solar application) and a magnetic lock is not used, terminals 10 and 11 may be used to provide power to other accessories.

PIN 7 = N.C. (Normally Closed)
 PIN 8 = Com (Common)
 PIN 9 = N.O. (Normally Open)
 PIN 10 = GND (Ground)
 PIN 11 = V+* POWER OUT

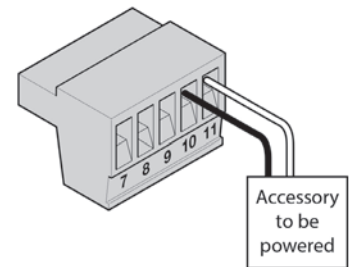
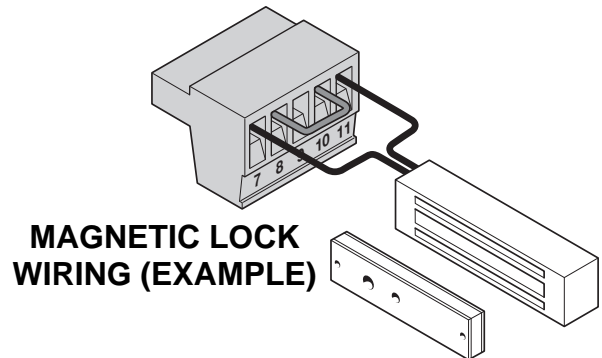

*NOTICE

The output voltage of terminal 11 is the same as the highest incoming voltage (on battery OR Main DC Power) to the control board.

EXAMPLES:

- If you are using a 12 VDC battery to power the control board connected to the Battery input, and the voltage of the battery is 13.5 VDC - terminal 11 will have a 13.5 VDC output.
- If you are using a power supply input of 32 VDC to the control board connected to the Main DC Power input - terminal 11 will have a 32 VDC output.
- If you are using a power supply connected to Main DC Power (at 32 VDC) and also using a battery connected to the Battery input (at 13.5 VDC) - terminal 11 will have an output of 32 VDC.

LAMP (12-13):

- Provides fused power (1.85A max) to drive a flashing warning lamp to indicate gate operation.
- This output is active when the gate is operating (Opening and Closing).
- Lamp Delay sets the amount of time the lamp accessory output is activated prior to gate movement. Settings from 0 to 5 seconds with a step of 0.5 seconds.

PIN 12 = LAMP PIN 13 = GND (Ground)
--

ALARM (14-15):

- Provides fused power (0.5A @ 12 VDC) to drive an alarm siren to signal the occurrence of a hard shutdown, caused by 2 consecutive entrapment events (signals).
- This alarm output is reset by pressing the “Reset Hard Shutdown” button on the front panel or activating the “FIRE” input.

PIN 14 = ALARM PIN 15 = GND (Ground)

24 VDC POWER OUTPUT (20-21):

- This power output is located along the lower strip of input connectors at pins 20 and 21.
- Pin 20 outputs a +24 Volts DC current, which is regulated and turns off when the control board goes into sleep mode (power saving mode).
- This output may be used to power accessories that are required to power-down when board enters power saving mode. This is primarily beneficial for solar powered configurations where it is desirable to reduce power consumption.

PIN 20 = +24 VDC Regulated PIN 21 = GND (Ground)

9.2 INPUT CONNECTORS

AUXILIARY INPUTS 1 & 2 (16-19):

- These digital inputs may be connected to the digital outputs of accessories and programmed to activate or control the gate operator in a number of different modes.
- Shorting the pins through a dry contact activates the programmed settings for these inputs.
- These inputs are programmed in the “FUNCTION Auxiliary I/O” menu.

PIN 16 = In1 (INPUT 1)
PIN 17 = GND (Ground)
PIN 18 = In2 (INPUT 2)
PIN 19 = GND (Ground)

SAFETY (LOOP) INPUT (22-23):

- Dry contact input that can be programmed for an inductive loop or photo-eye detector.
- Shorting the Safety Input (22) to GND reverses a closing gate to the full open position. The opened gate is held opened for as long as the input is active.
- This input is not for external entrapment sensors.

PIN 22 = Safety
PIN 23 = GND (Ground)

SHADOW (LOOP 1) INPUT (24-25):

- Dry contact input that can be programmed for an inductive loop or photo-eye detector.
- Shorting the Shadow Input (24) to GND maintains an OPEN gate fully open and a CLOSED gate fully closed until deactivated.
- Setting the Shadow Input to “Photo Mode” causes the opening gate to stop, then reopens the gate when the Shadow Input is deactivated.

PIN 24 = Shadow
PIN 25 = GND (Ground)

ENTRAPMENT (LOOP 2) INPUT (26-27):

- Dry contact input that can be programmed for an inductive safety loop or photo-eye detector.
- Shorting the ENTRAP input (26) to GND while the gate is opening cause the gate to close to the fully closed position.
- This input is not for external entrapment sensors.

PIN 26 = Entrap
PIN 27 = GND (Ground)

EDGE INPUT (28-29):

- The EDGE input may be configured as a monitored ANALOG input, or DIGITAL (NC or NO) input.
- The EDGE sensor input is intended for ANSI/UL 325 listed gate edge sensors to protect against entrapment and hazardous pinch points along the moving edge of the closing gate.
- Additional options are available to declare if the edge is protecting the open or close direction, and the input must measure 8.2K - 10K Ohms.
- When the input is activated it stops the gate regardless of direction of travel, momentarily reverses it then stops.

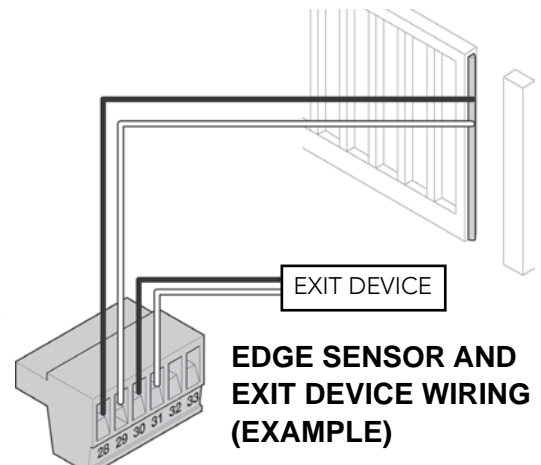

PIN 28 = EDGE
PIN 29 = GND

EXIT INPUT (30-31):

- The EXIT sensor input is provided to activate to open the gate, or re-open a closing gate, upon sensing an exiting vehicle.
- This is a dry contact input for a vehicle exit sensor.
- Shorting the EXIT input to GND opens gate from the closed position and holds gate open with maintained input or reverses gate if closing.

PIN 30 = EXIT
PIN 31 = GND

FIRE INPUT (32-33):

- Dry contact input for a fire department control switch.
- Shorting the Fire input (32) to GND opens the gate and holds the gate open until control switch is deactivated.
- Auto-close is disabled when this input is activated. Also clears hard shutdown.

PIN 32 = FIRE
PIN 33 = GND

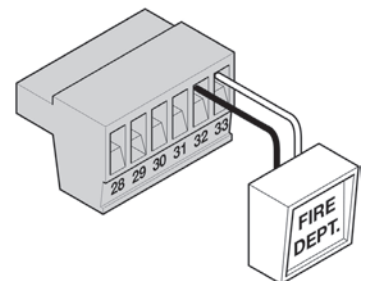

FIRE DEPT. INPUT WIRING (EXAMPLE)

GUARD STATION INPUT (34-37):

- With the Guard Station switches installed, the user can operate the gate by pushing the respective buttons for the command that is desired.
- Gate Open and Close are controlled by NORMALLY OPEN (NO) and Stop is controlled by NORMALLY CLOSED (NC) momentary switches.
- OPEN: (34) Dry contact input for a guard station open switch. Momentarily shorting the Open input (34) to GND opens the gate to the full open position with the subsequent auto-close feature enabled.
- STOP: (35) Dry contact input (Normally Closed) for a guard station stop switch. Momentarily opening the Stop input (35) stops the opening gate at its current position. While this input is activated, all other inputs are disabled and are not functional.
- CLOSE: (36) Dry contact input for a guard station close switch. Momentarily shorting the Close input (36) to GND closes the gate (primary and secondary).
- The FAIL SAFE connector which is shorted at the factory with a jumper (pins 35 & 37, Normally Closed NC), may be wired in parallel with the Fire input to release the motor in the event of an emergency entry by the fire department during a power failure.

PIN 34 = OPEN
PIN 35 = STOP
PIN 36 = CLOSE
PIN 37 = GND

GUARD STATION INPUTS WIRING (EXAMPLE)

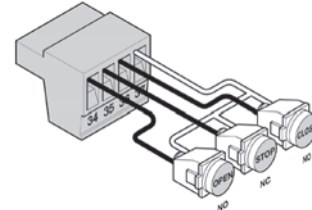

NOTICE

If the guard station inputs are not used, STOP (35) and GND (37) need to be tied together.

RADIO INPUTS (38-41):

- Customer supplied radio receiver can enable the gate operator to be operated via remote (wireless key-card readers or user remote controls).
- Open (39) is a dry contact input for an accessory radio open switch. Momentarily shorting the Open input (39) to GND (41) opens the gate to the full open position with the subsequent auto-close feature enabled.
- Close (40) is a dry contact input for an accessory radio close switch. Momentarily shorting the Close input (40) to GND (41) closes the gate.
- Connecting the Open (39) and Close (40) pins together with the relay of a receiver enables step by step gate control. This configuration allows a single button to control the gate in the following sequence:

- 1st Press = Gate **Open**
- 2nd Press = Gate **Stop**
- 3rd Press = Gate **Close**
- 4th Press = Gate **Stop**

PIN 38 = 12V
PIN 39 = OPEN
PIN 40 = CLOSE
PIN 41 = GND

NOTICE

12 VDC Power (PIN 38) is OFF when board enters Standby Mode. Power for external radio receivers should be sourced from Pin 11 in a solar application when the Standby mode is turned on.

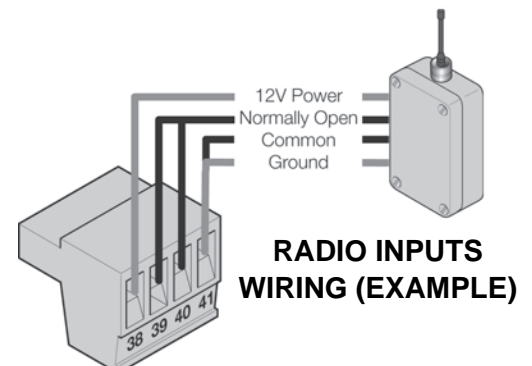

RADIO INPUTS WIRING (EXAMPLE)

PRIMARY/SECONDARY LINK CONNECTOR (38-41):

The Primary/Secondary control board as a secondary.

9.3 EMERGENCY VEHICLE ACCESS

The automatic vehicular gate system must be designed to allow access to emergency vehicles under different operating conditions. Read all the following information. Make sure that your gate operating system is compliant with all local codes and regulations and that access for emergency vehicles is assured.

- During normal operation, emergency vehicles access the gate by using an emergency vehicle access device installed on your gate system. The type of device that is used in your community is dependent on local city codes. These devices may include (but are not limited to) Fire Department lock boxes, Click-2-Enter radio receivers, strobe light sensors, siren sensors, etc.
- Check with your installer to determine if your gate system is equipped with a back-up power system. In the event of a primary (AC) power failure and a back-up system (DC) power failure (low charged or dead batteries for example), the system must have a release system to allow the gate to be manually operated. The release device must be accessible from either side of the gate and must be present so that emergency personnel can gain access through the gate under this condition.
- If applicable, this system is equipped with a manual release system that will allow the gate to be pushed open in the event of a power outage or equipment failure.

IMPORTANT!

Before manually opening the gate, verify that power has been shut off. To manually push open the gate:

- Titan912L actuator = Disengage mechanical release, then open the gate manually.
- 816 actuator = Remove the pin/bolt at gate attach bracket, then open the gate manually.
- 3501 operators = Flip the toggle switch under the drive chassis, pull the arms away from the gate at the elbow joint, then open the gate manually.

- In the event of a power failure, the emergency vehicle access device may not be functional because the gate operator is not powered.
- For manual fail-safe gate operation, turn power to the operator OFF. If a backup power system is in use, be sure that this power is turned OFF also or disconnected. Once power is OFF, the gate can be manually operated, by either releasing the actuator mechanical release or by disconnecting the actuator arm from the gate bracket. Note that a drop pin is included in the actuator bolt kit to allow fast decoupling of the actuator arm from the gate bracket.

NOTICE

DC powered back-up systems are optional and your gate system may or may not be equipped with one. Check with your installer to determine if your gate system is equipped with a back-up power system.

9.4 COMMUNICATIONS BUSES

The 1050 control board communication bus is described in this section.

OVIEW CONTROLLER:

- The Oview controller is an optional programming and diagnostic tool, which plugs directly into the 1050 control board using an RJ45 network cable and is part of the Nice “Opera” control system.
- The Oview controller can be used in “stand-alone” mode via its front-panel keypad, or it may be accessed via a Bluetooth-enabled PC when used with the optional OVBT module and Oview Software Suite.
- This unit, when matched with the optional Oview Bluetooth module (OVBT; see below) enables remote control and management of the gate controller.
- Remote control functions include most of the programming functions that are available at the front panel LCD on the control board as well as software updates.

OVBT MODULE:

The optional OVBT Bluetooth module is used with the Oview controller and the “Oview Software Suite” application for PC for localized wireless control of the gate controller.



**OVIEW
CONTROLLER**



**OPTIONAL
OVBT
MODULE**

SECTION 10: APPENDIX

10.1 CALCULATING SOLAR REQUIREMENTS

25 CALCULATING SOLAR REQUIREMENTS

1. Estimate the gate traffic measured in open/close cycles per TABLE 25-1.

TABLE 25-1: SOLAR PANEL WATT/CYCLE CHART						
DAILY CYCLES	1-10	1-20	1-40	1-60	1-80	80+
5 Watt Solar Panel	X					
10 Watt Solar Panel		X				
20 Watt Solar Panel			X			
30 Watt Solar Panel				X		
40 Watt Solar Panel (requires regulator)					X	
1.5 Amp Battery Charger					X	
10 Amp Battery Charger						X

NOTICE

- TABLE 25-1 should be used as only a guide. Alternative gate operator configurations may reduce or increase the daily power usage.
- For dual gate operators, double the amount of required solar wattage.
- If a standard electrical outlet is not available for trickle charging, a licensed electrician will be required for proper electrical hookup.

IMPORTANT!

Maximum regulator output is 1.5A. If installation requires larger than a 20W solar panel – an off-board regulator should be used and connected directly to the battery.

2. Estimate the amount of sunlight available per the Solar Map (right).
3. Use the solar wattage calculator found on the HySecurity website at <https://www.hysecurity.com/operators-accessories/solar/> to determine battery and solar panel size needed to serve the installation in question.

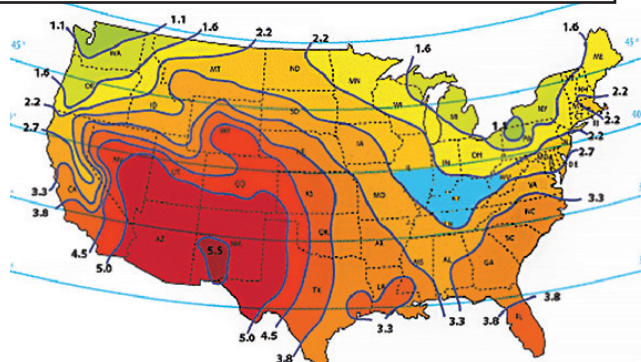

10.2 MAINTENANCE SCHEDULE

MAINTENANCE SCHEDULE			
Component	Maintenance Action	6 Months	Annually
ALARM	Activate the primary (inherent) reverse system by blocking the gate with a solid object. The gate should reverse momentarily then stop. Restart the gate and block again with a solid object. The gate should reverse momentarily, then stop, and go into hard shutdown with an alarm.	X	X
BACKUP SYSTEM	If operator is equipped with option DC backup system, check to be sure the system opens the gate upon loss of AC power.	X	X
BATTERY	If operator is equipped with option DC backup system, check the batteries for any leakage or loose connections. Batteries should be replaced every two years.	X	X
FIRE DEPT	Check emergency vehicle access device for proper operation.	X	X
GATE	Inspect for damage.		X
LOOP(S)	Check vehicular reverse and shadow loops for proper operation.	X	X
RELEASE	Check manual release for proper operation.	X	X
MOUNTING HARDWARE	Check screws and nuts.		X
PHOTO EYES	Use a hand held cylinder (approx. 2" [5cm] diameter and 12" [30cm] in length) and pass between photo eye line of sight. Pass cylinder through line of sight near transmitter, pass cylinder through line of sight near receiver, pass cylinder through line of sight halfway between transmitter and receiver. Gate should stop and reverse on detection. Check for humidity, oxidation, and foreign bodies (such as insects) and remove from chassis. Clean housings and front plate. Do not use alcohol, benzene, abrasives or other cleaning products. Use only a slightly dampened soft cloth to clean transmissive panels or lenses.	X	X

10.3 SYSTEM TROUBLESHOOTING

SYSTEM TROUBLESHOOTING	
Problem	Possible Solution
Gate opens a short distance, then stops and reverses.	<ul style="list-style-type: none"> • Check the UL/Edge input on the gate controller. • Ensure limit LEDs are functioning properly. • Check for obstructions. • Adjust Force Settings.
Gate opens but will not close.	<ul style="list-style-type: none"> • Check the input LEDs. Any ON will hold the gate open and indicates a problem with a keying device. Exception is "STOP". • Check the external safety devices. Any activated safety devices will hold the gate open and indicates a problem with the safety device. • Check limit LEDs. Orange LED indicates both open/close at same times. Check limits for failures. Replace as necessary. • Check the loop detectors. Any activated safety devices can hold the gate open and indicates a problem with the loop detector or ground loop.
Battery backup system will not open gate upon AC power outage.	<ul style="list-style-type: none"> • Check if backup system is set to open gate automatically or requires an input to open (Functions>Advanced). • Check batteries for proper voltage. Replace if necessary (Display>Battery Volt). • Check incoming Main DC Power (Display>Main Volt.).
Hard Shutdown (two back to back obstructions) LED blinking, Buzzer sounds for 5 minutes.	Clear any obstructions from the path of the gate. Press RESET to clear (or hard reset button).
Gate opens by itself.	Check accessory inputs and clear them as necessary. Also check to ensure the Event programming has not been set to open the gate at a particular time.
1050 display shows repeated "Nice Apollo 1050" when a button is pressed.	Check battery voltage and replace if necessary (Display>Battery Volt).
Gate moves in direction opposite expected.	Reverse the actuators Red and Black motor wires connected to the 1050 control board.
Limit LED glows green when gate is closed, and red when open.	Reverse the actuators Orange and White encoder wires connected to the 1050 control board.

10.4 INSTALLATION CHECKLIST

- The installer and customer must each ensure that all of the following actions have been completed.
- Left box is for installer check off and the right box is for customer check off.

INSTALLATION CHECKLIST		
<input type="checkbox"/>	<input type="checkbox"/>	The gate has been checked to make sure it is level and moves freely in both directions.
<input type="checkbox"/>	<input type="checkbox"/>	Potential pinch areas have been guarded so as to be inaccessible OR have contact and/or non-contact obstruction sensing devices installed.
<input type="checkbox"/>	<input type="checkbox"/>	The installer has installed one or more contact or non-contact obstruction sensing devices, in compliance with UL325 requirements for this installation.
<input type="checkbox"/>	<input type="checkbox"/>	If pedestrian traffic is expected, a separate pedestrian gate has been installed, a minimum of seven feet from the gate. The customer has been informed that all pedestrian traffic must use the pedestrian gate.
<input type="checkbox"/>	<input type="checkbox"/>	Warning signs have been installed on each side of the gate in highly visible locations. The customer has been informed that these signs must remain at all times.
<input type="checkbox"/>	<input type="checkbox"/>	There are no controls installed within 6 feet of the gate.
<input type="checkbox"/>	<input type="checkbox"/>	The installer has properly adjusted the obstruction sensing feature and has tested the gate to make sure that the gate stops and reverses a short distance with minimal resistance applied (Approximately 40 lbs. on a swing gate, at the end of the gate).
<input type="checkbox"/>	<input type="checkbox"/>	The installer has instructed the customer in the proper use of the gate operator and reviewed all of the operational functions, obstruction sensing devices, warning beeper and reset, etc.
<input type="checkbox"/>	<input type="checkbox"/>	The installer has instructed the customer in the proper way of disconnecting the operator. Manual disconnect must never be used while the gate is in motion. The power must be turned off and battery disconnected before disengaging the operator.
<input type="checkbox"/>	<input type="checkbox"/>	The installer has reviewed all safety instructions with the customer, and has left the safety instructions and owner's manual for their reference.
<input type="checkbox"/>	<input type="checkbox"/>	The installer has answered any questions the customer has regarding the operation of the gate operator and gate operator safety precautions.
<input type="checkbox"/>	<input type="checkbox"/>	The installer has explained to the customer that a regular maintenance schedule for both the gate and the gate operator is recommended.
<input type="checkbox"/>	<input type="checkbox"/>	The installer has given any keys for the control box and actuator release to the customer and explained how to manually open the gate in the event of a loss of power.

10.5 PART DRAWINGS

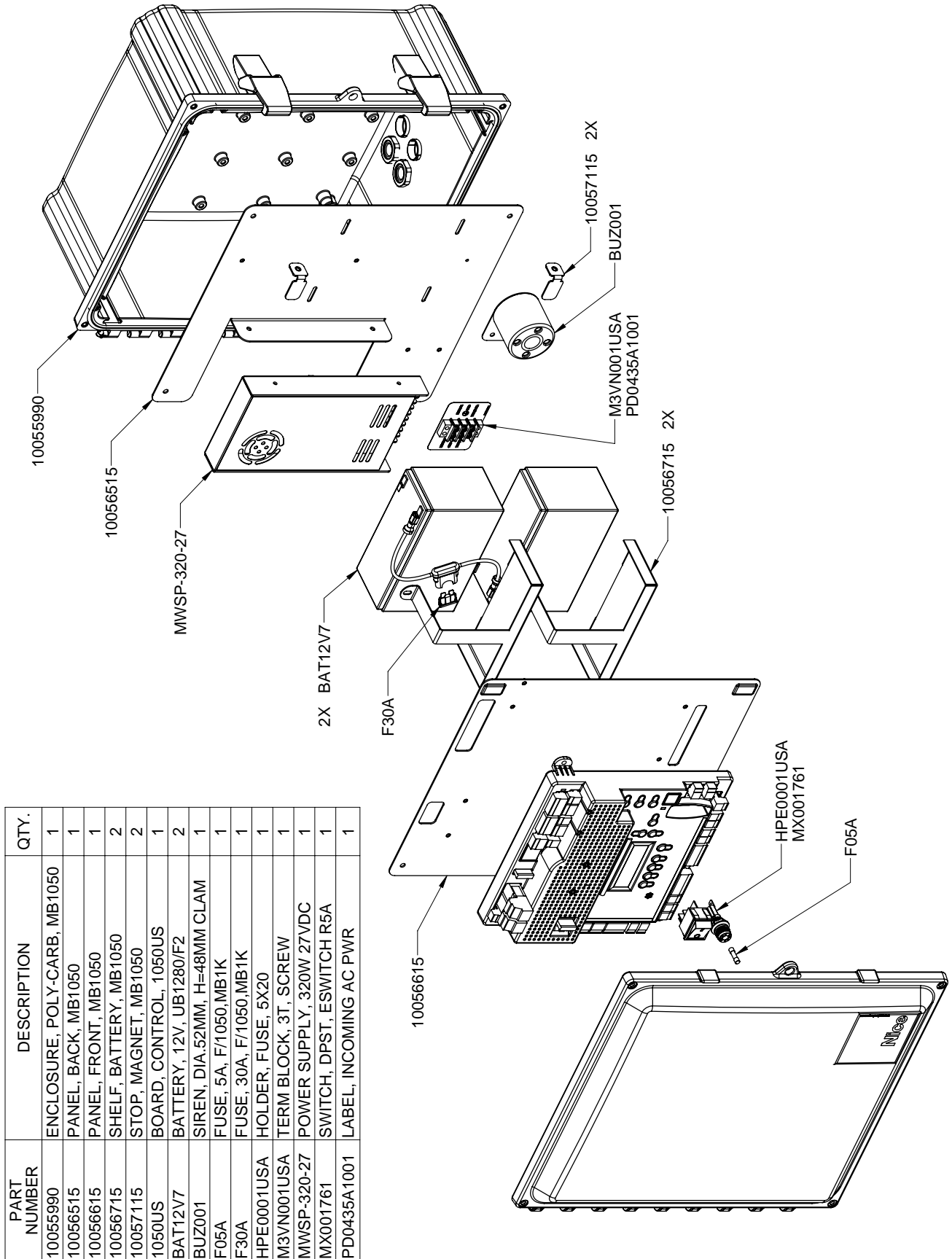

PART NUMBER	DESCRIPTION	QTY.
10055990	ENCLOSURE, POLY-CARB, MB1050	1
10056515	PANEL, BACK, MB1050	1
10056615	PANEL, FRONT, MB1050	1
10056715	SHELF, BATTERY, MB1050	2
10057115	STOP, MAGNET, MB1050	2
1050US	BOARD, CONTROL, 1050US	1
BAT12V7	BATTERY, 12V, UB1280/F2	2
BUZ001	SIREN, DIA.52MM, H=48MM CLAM	1
F05A	FUSE, 5A, F/1050, MB1K	1
F30A	FUSE, 30A, F/1050, MB1K	1
HPE0001USA	HOLDER, FUSE, 5X20	1
M3VN001USA	TERM BLOCK, 3T, SCREW	1
MWSP-320-27	POWER SUPPLY, 320W 27VDC	1
MX001761	SWITCH, DPST, ESWITCH R5A	1
PD0435A1001	LABEL, INCOMING AC PWR	1

(This page intentionally blank)

SECTION 11: WARRANTY**LIMITED WARRANTY—NICE-BRANDED PRODUCTS****1. Warranty.**

Hy-Security Gate, Inc. ("HySecurity") warrants that at the time of sale, each Nice-branded gate operator product that it sells will, in all material respects, conform to the then applicable specification for the product and will be free from defects in material and manufacture.

The following additional durational warranties apply to products purchased through a distributor authorized by HySecurity to sell Nice products ("Authorized Distributor"), depending on whether (1) the product is purchased through an Authorized Distributor and (2) whether a timely and complete product registration is submitted to HySecurity.

It is therefore important that you register your product with HySecurity, online at www.hysecurity.com/warranty, within the 60-day period described below.

1(a) Nice-branded Products Purchased Through Authorized Distributors and Properly Registered

For any gate operator product that is purchased from an Authorized Distributor (this excludes product purchased through internet resellers or any distributor not authorized by HySecurity to sell Nice products), if the product registration is completed by the Dealer/Installer or End User within 60 days of the date of purchase, the following warranty terms will apply. HySecurity warrants that the product will remain serviceable for the following periods:

- a) Electromechanical pad-mounted Slide and Swing operators: Three years after the date of installation,
- b) Electromechanical linear actuator Swing operators: Three years after the date of installation,
- c) Electromechanical barrier arm operators: Three years after the date of installation,
- d) Nice-branded accessories: Three years after the date of installation, *provided that* the Three-Year warranty period in (a), (b), or (c) will not extend beyond four years from the date that the product was shipped from HySecurity.

The preceding warranty durations do not apply to the products or components described below (e-f), which have a shorter warranty period:

- e) Batteries: One Year from date of shipment from HySecurity.
- f) Components subject to normal wear including, but not limited to, chains, belts, idler wheels, sprockets and fuses: One Year from date of installation.

1(b) Nice Products Not Purchased Through an Authorized Distributor or Not Properly Registered within 60 Days

For any product that is not purchased from an Authorized Distributor or for which the product registration was not completed by the Dealer/Installer/End User within sixty (60) days of the date of purchase, the following **Two-Year Limited Warranty** will apply: HySecurity warrants that the product will remain serviceable for Two Years from the date that the product was shipped from HySecurity.

1(c) Replacement Parts

HySecurity warrants that replacement parts (whether new or reconditioned) will remain serviceable for One Year from the date that the part was shipped from HySecurity or the remaining period of the Gate Operator warranty, whichever is longer.

1(d) Limitations and Exclusions Applicable to Each of the Preceding Warranties.

The preceding warranties shall not apply to equipment that has been (1) installed, maintained, or used improperly or contrary to instructions; (2) subjected to negligence, accident, vandalism, or damaged by severe weather, wind, flood, fire, terrorism or war; or (3) damaged through improper operation, maintenance, storage or abnormal or extraordinary use or abuse. Any modification made to products will void the warranty unless the modifications are approved in writing by HySecurity in advance of the change (this exclusion does not apply to normal installation of approved accessories and/or protective devices or sensors). It is the responsibility of the Distributor, Dealer/Installer, or End User to ensure that the software version in the product is maintained to the latest revision level.

The preceding warranties do not extend to accessories when those items carry the name plate of a manufacturer other than HySecurity or Nice and they are not a part of the base model. HySecurity disclaims all warranties for such accessory components, which carry only the original warranty, if any, of their original manufacturer. HySecurity hereby assigns its rights under such manufacturer warranties—to the extent that such rights are assignable—to Buyer.

This warranty gives you specific legal rights, and you may also have other rights which vary from State to State.

These warranties extend to HySecurity's Distributors, to the Dealer/Installer, and to the first End User of the product following installation. They do not extend to subsequent purchasers. **2. Limitation of Certain Implied Warranties and Exclusion of Other Warranties.**

The warranties contained in Section 1 are the exclusive express warranties given by HySecurity and supersede any previous, contrary or additional representations, whether oral or written. Any prior or extrinsic representations or agreements are discharged or nullified. ANY IMPLIED WARRANTIES, INCLUDING ANY WARRANTY OF MERCHANTABILITY OR WARRANTY OF FITNESS FOR A PARTICULAR PURPOSE, ARE LIMITED IN DURATION TO PERIOD OF THE APPLICABLE EXPRESS WARRANTY FOR THE PRODUCT OR COMPONENT. HYSECURITY HEREBY DISCLAIMS AND EXCLUDES ALL OTHER WARRANTIES—INCLUDING ANY LIABILITY FOR INFRINGEMENT, AND ANY WARRANTIES OTHERWISE ARISING FROM COURSE OF DEALING, COURSE OF PERFORMANCE, OR USAGE OF TRADE.

Some states do not allow limitations on how long an implied warranty lasts, so the above limitation may not apply to you.

3. Buyer's Exclusive Remedies for Any Nonconformity.

If a Nice product fails to conform to the warranties in Section 1, Buyer must notify and order replacement parts from the Distributor through which the product was purchased within a reasonable time and in no event more than thirty (30) days after the discovery of the nonconformity. HySecurity will investigate and, in the event of a breach, will provide, within a reasonable period of time, one of the following: (1) repair or replacement of any nonconforming products or components or (2) refund of the price upon return of the nonconforming items. HySecurity reserves the right to supply used or reconditioned material for all warranty claims. HySecurity will not be considered to be in breach of or default under this Warranty because of any failure to perform due to conditions beyond its reasonable control, including any force majeure. This warranty does not cover any incidental expenses, including fines or penalties, temporary security, labor, shipping, travel time or standby time that are incurred for inspection or replacement of any nonconforming items. As a condition of warranty coverage, warranty claims must be submitted in accordance with the procedures described on the HySecurity form, "RMA Procedures."

THE REMEDY SELECTED BY HYSECURITY IN ACCORDANCE WITH THIS PARAGRAPH SHALL BE THE **EXCLUSIVE AND SOLE REMEDY OF BUYER FOR ANY BREACH OF WARRANTY.**

4. Exclusion of Consequential and Incidental Damages.

HYSECURITY AND NICE SHALL NOT BE LIABLE FOR ANY INCIDENTAL, SPECIAL, OR CONSEQUENTIAL DAMAGES, WHETHER RESULTING FROM NONDELIVERY OR FROM THE USE, MISUSE, OR INABILITY TO USE THE PRODUCT OR FROM DEFECTS IN THE PRODUCT OR FROM HYSECURITY'S OR NICE'S OWN NEGLIGENCE. This exclusion applies regardless of whether such damages are sought for breach of warranty, breach of contract, negligence, or strict liability. This exclusion does not apply to claims for bodily injury or death.

Some states do not allow the exclusion or limitation of incidental or consequential damages, so the above limitation may not apply to you.

5. Severability.

If any provision of this warranty is found to be invalid or unenforceable, then the remainder shall have full force and effect.

6. Proprietary Rights.

HySecurity and Nice retain and reserve all right, title, and interest in the intellectual property rights of their products, including any accompanying proprietary software. No ownership of any intellectual property rights in the products or accompanying software is transferred to Distributor, Dealer/Installer, or End User.

7. Applicable Law.

This warranty will be interpreted, construed, and enforced in all respects in accordance with the laws of the State of Washington, without reference to its choice of law principles. The U.N. Convention on Contracts for the International Sale of Goods will not apply to this warranty.

MB1050

Installation and Programming Manual

DOCUMENT REVISIONS

NAME	DESCRIPTION OF CHANGE	DATE
Curtis Harvey	Rev D: Changed all 1050 controller SS images with new logo and replaced "Master/Slave" with "Primary/Secondary" per ECO# 10517. Replaced image (page 4) and instances of MX4257 with EPMORB/A reflective photo eye per ECO# 10525.	03/01/2022
Curtis Harvey	Rev E: corrected Figure 9-1 by copying Motor 2 connector wiring to Motor 1 connector.	05/13/2022

INSTALLATION INFORMATION AND SIGN-OFFS

Installation Acceptance

Address where opener is located

Installer name, number and address

End user name and telephone number

Contact us:
 Nice/HySecurity
 Kent, WA 98032
 800-321-9947
 hysecurity.com