

# SwingSmart™ 535



## Swing Gate Operator

Advanced Installation and Programming Manual

**Nice**

# Table of Contents

<b>Safety Requirements</b> .....	<b>5</b>
IMPORTANT SAFETY INSTRUCTIONS.....	6
General Safety Information .....	6
IDENTIFYING GATE OPERATOR CATEGORY AND UL 325 USAGE CLASS.....	7
Vehicular Traffic Only.....	8
Use of Vehicle Detectors.....	9
Gate Construction and Safety.....	9
Maintenance of Gate Systems.....	10
Entrapment Protection .....	10
Compatible External Sensors.....	11
Stop Button.....	13
Manual Release.....	13
<b>Features</b> .....	<b>14</b>
<b>Unpack the Operator</b> .....	<b>15</b>
Unpack the Operator .....	15
General Operator Dimensions.....	15
<b>Operator Position</b> .....	<b>16</b>
New Installation.....	16
Retrofit Installation .....	16
<b>Prepare Installation Site</b> .....	<b>17</b>
4 Internal Post Mount, 3" OD, U-Bolt Attachment.....	20
4 External Post Mount, 3" OD, U-Bolt Attachment.....	21
4 Internal Post Mount, 3" OD, Weld Attachment .....	22
<b>Install Arm Assembly</b> .....	<b>23</b>
<b>Install and Adjust the Limit Sensors</b> .....	<b>25</b>
Adjust the Limit Sensors .....	25
<b>Attach Back Cover</b> .....	<b>27</b>
<b>Adjust Taper Clamp and Attach Top Cap</b> .....	<b>28</b>
<b>Wiring and Power</b> .....	<b>29</b>
Wiring 115VAC or 208/230VAC Power.....	29
Low Voltage Control Wiring: WIRE GAUGE AND DISTANCE .....	31
<b>Solar Power</b> .....	<b>32</b>
USING A SOLAR POWERED OPERATOR .....	32
Glossary of Solar Powered Operator Terms.....	32
Design Requirements & Considerations .....	32
Connecting the SwingSmart 535 to a Solar Panel System.....	33
Connecting Peripherals to Solar Operators .....	33
Understanding Gate Activity Based on Solar Zones.....	34
Important Considerations For Battery Powered Operators .....	35
<b>Extended Battery Kit</b> .....	<b>36</b>
Install Extended Battery Kit.....	36
<b>Controller Connections</b> .....	<b>37</b>
<b>User Interface</b> .....	<b>38</b>
<b>Initial Setup</b> .....	<b>39</b>
Configure the Setup Menu (SWING) .....	39
Navigate the Menus .....	39
<b>SmartTouch 725 Controller Menus</b> .....	<b>40</b>
<b>Operator Configurations</b> .....	<b>41</b>
<b>Operator Communications</b> .....	<b>45</b>

- Bi-Parting Gate Setup** ..... 47
  - Bi-Parting Gate Setup: ..... 47
  - Sequenced Gate Wiring: ..... 47
- Vehicle Detector Loop Layouts**..... 48
- Sequenced Gate: Loop View #1** ..... 50
- Sequenced Gate: Loop View #2** ..... 51
- Programmable Inputs**..... 52
- Controller Inputs**..... 54
- Entrapment Sensor Wiring - BlueBUS**..... 55
- Entrapment Sensor Wiring**..... 56
- Approved Sensor Wiring** ..... 57
- Entrapment Sensor Response**..... 61
- Set IES Sensitivity** ..... 63
- User Relay Outputs** ..... 64
- Relay Outputs - Basic** ..... 68
- Relay Outputs - Mechanical** ..... 69
- Relay Outputs - Solid State** ..... 70
- SmartTouch 725 - HY5B Module** ..... 71
  - Install an HY5B and Vehicle Loop Detector ..... 71
- Loop Options**..... 72
- SmartTouch 725 - HY5B Loop Diagnostics**..... 75
- External Communications**..... 77
- Firmware Updates and Debug Data** ..... 79
- Connect to the HySecurity Installer App**..... 80
  - Set Bluetooth Switch: ..... 80
  - Enable Bluetooth in the Menus: ..... 80
  - Connect the App and Controller: ..... 80
- External Communications**..... 81
- OXI MegaCode Receiver and Programming**..... 83
- Expansion Board Inputs**..... 84
- I/O Expansion Module Mounting and Wiring** ..... 85
- Diagnostics Menu**..... 86
- 24/7 Clock and Timer** ..... 87
- Maintenance** ..... 89
  - Mechanical Maintenance ..... 89
  - Fuse Replacement ..... 89
  - DC Battery Replacement ..... 89
- Additional Safety Information** ..... 90
  - Electrical Safety..... 90
  - Grounding Safety ..... 90
  - Battery Safety..... 90
  - Environmental Safety/Hazardous Materials and Proper Disposal ..... 91
- Troubleshooting/Alerts/Faults/Errors** ..... 92

Appendix - French Translations..... 99

Warranty..... 103

Specifications..... 104

    SwingSmart™ 535 Model, AC or Solar..... 104

# Safety Requirements

## SAFETY MESSAGES

The safety messages below inform you about potential hazards that can result in injury. Safety messages specifically address level of exposure to operator and are preceded by one of four words: **DANGER**, **WARNING**, **CAUTION**, or **NOTICE**.

 **DANGER**

Indicates a hazardous situation which, if not avoided, **WILL** result in **DEATH** or **SERIOUS INJURY**.

 **WARNING**

Indicates a hazardous situation which, if not avoided, **COULD** result in **DEATH** or **SERIOUS INJURY**.

 **CAUTION**

Indicates a hazardous situation which, if not avoided, **COULD** result in **MINOR** or **MODERATE INJURY**.

**NOTICE**

Addresses practices not related to personal injury. Indicates damage to equipment is probable if the hazardous situation is not avoided.

## COMMON INDUSTRIAL SYMBOLS

These international safety symbols may appear on product or in its literature to alert of potential personal injury hazards. Obey all safety messages that follow these symbols to avoid possible injury or death.

Symbol	Safety Hazard
	Attention - Take Notice
	Danger - Keep Away
	Entrapment Zone
	Possible Pinch Point

# Safety Requirements

## IMPORTANT SAFETY INSTRUCTIONS

Hazards, associated with automatic gates, can be reduced with proper site design, installation, and use. Installers, maintenance crews, and owners/users must read and follow the safety requirements found in HySecurity® product manuals.



It is important that only qualified installers handle installation of HySecurity Gate vehicular gate operators. A “qualified” installer has one of the following:



1. A minimum of three years experience installing similar equipment.
2. Proof of attending a HySecurity Technical Training seminar within the past three years.
3. Significant manufacturer endorsements of technical aptitude in gate operator installation and operation.

Underwriter Laboratories (UL) and the American Society for Testing and Materials (ASTM) are responsible for current safety standards and regulations regarding gate operators and automated gates. All aspects of gate installation must comply with the appropriate safety standard. For the most up-to-date ASTM F2200 Gate and Fence Standards, refer to [www.astm.org](http://www.astm.org). For UL 325 Safety Standard, refer to [www.ul.com](http://www.ul.com). Consult local government agencies for up-to-date rules and regulations as certain municipalities have established licensing, codes or regulations that regulate automated gate system design and installation.

## GENERAL SAFETY INFORMATION

A gate operator is only a component in a gate system. The other parts of the gate system can include the gate, the external safety sensors, access controls, and vehicle detectors. To have a gate system that provides for safety, security, and reliable operation it is essential these components operate together as a system. It is the responsibility of the system designer and/or installer to ensure any safety or operational issues have been addressed.

## WARNING

To reduce the risk of injury or death:

1. READ AND FOLLOW ALL INSTRUCTIONS.
2. Never let children operate or play with gate controls. Keep the remote control away from children.
3. Always keep people and objects away from the gate. **NO ONE SHOULD CROSS THE PATH OF THE MOVING GATE.**
4. Test the gate operator monthly. The gate **MUST** reverse on contact with a rigid object or stop when an object activates the non-contact sensors. After adjusting the force or the limit travel, retest the gate operator. Failure to adjust and retest the gate operator can increase the risk of injury or death.
5. Use the manual release only when the gate is not moving.
6. **KEEP GATES PROPERLY MAINTAINED.** Read the user's manual. Have a qualified service person make repairs to gate hardware.
7. The entrance is for vehicles only. Pedestrians must use separate entrance.
8. **SAVE THESE INSTRUCTIONS.**

# Safety Requirements

## IDENTIFYING GATE OPERATOR CATEGORY AND UL 325 USAGE CLASS

The UL 325 standard covers gate operators. Within this safety standard several Usage Classes are described that define different types of installations where gate operators can be applied. Some operators are restricted in their usage application. Appropriate Usage Classes are shown in the Specifications.

**Class I**



Class I: Intended for use in a location of one to four single family dwellings or a parking area associated with one to four single family dwellings.

**Class II**



Class II: Intended for use in a commercial location or building such as a multi-family housing units (five or more single family units) hotels, garages, retail stores or other buildings servicing general public.

**Class III**

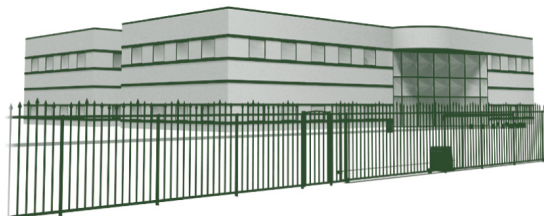

Class III: Intended for use in an industrial location or building such as factories or loading docks or other locations not accessible by the general public.

**Class IV**



Class IV: Intended for use in guarded industrial locations or buildings such as an airport security area or other restricted access location, not servicing general public, in which access is monitored by security personnel or via closed circuitry.

# Safety Requirements

## WARNING

This automatic gate operator is not designed nor is it intended for pedestrian traffic. Vehicular gate operators must by their nature be powerful to function reliably. This power can cause injury or death. Accordingly, direct all pedestrian traffic to a separate walk-through gate.

## VEHICULAR TRAFFIC ONLY

### Install this gate operator only when:

- The operator is appropriate for the construction of the gate and the usage Class of the gate.
- All openings of a horizontal slide gate are guarded or screened from the bottom of the gate to a minimum of 1.83 m (6 ft) above the ground to prevent a 57.2 mm (2-1/4 in) diameter sphere from passing through the openings anywhere in the gate, and in that portion of the adjacent fence that the gate covers in the open position.
- All exposed pinch points are eliminated or guarded.
- Guarding is supplied for exposed rollers.

The operator is intended for installation only on gates used for vehicles. Pedestrians must be supplied with a separate access opening. The pedestrian access opening shall be designed to promote pedestrian usage. Locate the gate such that persons will not come in contact with the vehicular gate during the entire path of travel of the vehicular gate.

The gate must be installed in a location so that enough clearance is supplied between the gate and adjacent structures when opening and closing to reduce the risk of entrapment. Swinging gates shall not open into public access areas.

The gate must be properly installed and work freely in both directions prior to the installation of the gate operator. Do not over-tighten the operator clutch or pressure relief valve to compensate for an improperly installed, improperly functioning, or damaged gate.

Permanently mounted controls intended for user activation must be located at least 1.83 m (6 ft) away from any moving part of the gate and where the user is prevented from reaching over, under, around, or through the gate to operate the controls.

- Exception: Emergency access controls only accessible by authorized personnel (e.g. fire, police, EMS) may be placed at any location in the line-of-sight of the gate.

The Stop and/or Reset button must be located in the line-of-sight of the gate. Activation of the reset control shall not cause the operator to start.

A minimum of two (2) WARNING SIGNS shall be installed, in the area of the gate. Each placard is to be visible by persons located on the side of the gate on which the placard is installed.

### For gate operators utilizing a non-contact sensor (Photo Eye):

- See instructions on the placement of non-contact sensors for each type of application.
- Care shall be exercised to reduce the risk of nuisance tripping, such as when a vehicle trips the sensor while the gate is moving.
- One or more non-contact sensors shall be located where the risk of entrapment or obstruction exists, such as the perimeter reachable by a moving gate or barrier.

### For a gate operator utilizing a contact sensor (Edge):

- One or more contact sensors shall be located where the risk of entrapment or obstruction exists, such as at the leading edge, trailing edge, and post mounted both inside and outside of a vehicular horizontal slide gate.
- A hardwired contact sensor shall be located and its wiring arranged so that the communication between the sensor and the gate operator is not subjected to mechanical damage.
- A wireless device such as one that transmits radio frequency (RF) signals to the gate operator for entrapment protection functions shall be located where the transmission of the signals are not obstructed or impeded by building structures, natural landscaping or similar obstruction. A wireless device shall function under the intended end-use conditions.

# Safety Requirements

- One or more contact sensors shall be located on the inside and outside leading edge of a swing gate. Additionally, if the bottom edge of a swing gate is greater than 152 mm (6 in) but less than 406 mm (16 in) above the ground at any point in its arc of travel, one or more contact sensors shall be located on the bottom edge.

## USE OF VEHICLE DETECTORS

Use of vehicle detectors (loop detectors) is strongly encouraged to prevent damage to vehicles caused by gates closing on them. This is not considered to be a safety item as vehicle detectors cannot provide protection to pedestrians. In some situations, photoelectric devices may be used as vehicle detectors, but should be wired accordingly.

## GATE CONSTRUCTION AND SAFETY

Gate construction plays a very important role in ensuring the safety of any automated gate system. The standard for gate construction is ASTM F2200. Below are key areas to address in gate design for safety. For complete information consult the standard. Copies of the standard are available at:

<https://www.astm.org/Standards/F2200.htm>.

Another source of information is available from DASMA, the Door and Access System Manufacturer's Association. The Association publishes Technical Data Sheets, one of which concerns ASTM F2200. For more information, see:

<http://www.dasma.com/PDF/Publications/TechDataSheets/OperatorElectronics/TDS370.pdf>.

### General Requirements for Gate Construction:

- Gates shall be constructed in accordance with the provisions given for the appropriate gate type listed. Refer to ASTM F2200 for additional gate types.
- Gates shall be designed, constructed and installed to not fall over more than 45 degrees from the vertical plane, when a gate is detached from the supporting hardware.
- Gates shall have smooth bottom edges, with vertical bottom edged protrusions not exceeding 0.50 in (12.7 mm) other than the Exceptions listed ASTM F2200.

- The minimum height for barbed wire shall not be less than 6 ft (1.83 m) above grade. The minimum height for barbed tape shall not be less than 8 ft (2.44 m) above grade.
- An existing gate latch shall be disabled when a manually operated gate is retrofitted with a powered gate operator.
- A gate latch shall not be installed on an automatically operated gate.
- Protrusions shall not be permitted on any gate. Consult ASTM F2200 for exceptions.
- Gates shall be designed, constructed and installed such that their movement shall not be initiated by gravity when an automatic operator is disconnected.
- For pedestrian access in the vicinity of an automated vehicular gate, a separate pedestrian gate shall be provided. The pedestrian gate shall be installed in a location such that a pedestrian shall not come in contact with a moving vehicular access gate. A pedestrian gate shall not be incorporated into an automated vehicular gate panel.
- Any non-automated gate that is to be automated shall be upgraded to conform to the provisions of this specification.
- This specification shall not apply to gates generally used for pedestrian access and to vehicular gates not to be automated.
- Any existing automated gate, when the operator requires replacement, shall be upgraded to conform to the provisions of this specification in effect at that time.

# Safety Requirements

## The following requirements shall apply to Class I, Class II, Class III, and Class IV vehicular horizontal slide gates:

All weight bearing exposed rollers 8 ft (2.44 m), or less, above grade shall be guarded or covered.

All openings shall be designed, guarded, or screened from the bottom of the gate to the top of the gate or a minimum of 72 inch (1.83 m) above grade, whichever is less, to prevent a 2-1/4 inch (57 mm) diameter sphere from passing through the openings anywhere in the gate, and in that portion of the adjacent fence that the gate covers in the open position. The gate panel shall include the entire section of the moving gate, including any back frame or counterbalance portion of the gate.

A gap, measured in the horizontal plane parallel to the roadway, between a fixed stationary object nearest the roadway (such as a gate support post) and the gate frame when the gate is in either the fully open position or the fully closed position, shall not exceed 2-1/4 inches (57 mm).

- Exception: All other fixed stationary objects greater than 16 inches (406 mm) from the gate frame shall not be required to comply with this section.

Positive stops shall be required to limit travel to the designed fully open and fully closed positions. These stops shall be installed at either the top of the gate, or at the bottom of the gate where such stops shall horizontally or vertically project no more than is required to perform their intended function.

All gates shall be designed with sufficient lateral stability to assure that the gate will enter a receiver guide. Consult ASTM F2200 for details on various gate panel types.

## MAINTENANCE OF GATE SYSTEMS

To keep your automated gate system performing both safely and reliably it is important to ensure that the components of that system are functioning properly.

### At least monthly:

- Disconnect the gate operator and manually move the gate through its range of travel. Note any squeaks from rollers or hinges or areas of binding. The gate should travel smoothly and quietly throughout its range. If it does not, contact a gate professional to correct the problem.

- Reconnect the gate operator and perform the following tests:
  - With the gate opening, block any photo eyes and/or depress any safety edges used to protect the open direction. The gate should stop and/or reverse.
  - With the gate closing, block any photo eyes and/or depress any safety edges used to protect the close direction. The gate should stop and/or reverse.
  - Using a suitable obstruction in the path of the gate (a solid, immovable object), run the gate in the open direction until it contacts the obstruction. The gate should stop and reverse.
  - Using a suitable obstruction in the path of the gate (a solid, immovable object), run the gate in the close direction until it contacts the obstruction. The gate should stop and reverse.

## ENTRAPMENT PROTECTION

The UL 325 standard for gate operators requires a minimum of two independent entrapment protection means for each entrapment zone.

### An entrapment zone is defined as follows:

For swing gates, locations between a moving gate or moving, exposed operator components and a counter opposing edge or surface where entrapment is possible up to a height of 6 ft (1.83 m) above grade. Such locations occur if at any point in travel:

- The gap between the bottom of a moving gate and the ground is greater than 4 inches (101.6 mm) and less than 16 inches (406 mm); or
- The distance between the center line of the pivot and the end of the wall, pillar, or column to which it is mounted when in the open or closed position exceeds 4 inches (101.6 mm). Any other gap between a moving gate and fixed counter opposing edges or surfaces or other fixed objects is less than 16 inches (406 mm) (examples are walls, curbs, berms or other immovable objects).

# Safety Requirements

All Nice HySecurity gate operators feature an Inherent Entrapment System (IES) (UL 325 Type A) that monitors the force on the gate during travel. This system protects in both the open and close direction and reverses on contact with an obstruction. The IES serves as one of the means of entrapment protection.

Potential entrapment zones for swing gates are shown on page 12, but keep in mind there may be other entrapment zones presented by the actual installation and adjacent structures or landscape that must be protected as well.

External sensors must be used to protect against entrapment at each location where an entrapment zone exists. The minimum number of external sensors required to enable automatic operation of the gate operator is as follows:

- Swing Gates: One external sensor in the direction where an entrapment zone exists (provided there is no risk of entrapment in the other direction).

The gate operator tests for the presence of these sensors, and if the required minimum number is not found, the operator will only run using continuous pressure on an Open/Close button, either on the controller, or an external device.

## COMPATIBLE EXTERNAL SENSORS

### NOTICE

The following sensors have been tested with Nice | HySecurity gate operators by an independent laboratory and certified to comply with UL 325 7th Edition. Select sensors from this list for UL compliant gate automation solutions. Contact the sensor manufacturer for specific recommendations for use.

**Table 1. Recommended External Entrapment Protection Sensors List**

Recommended Sensors					Compatible Control Boards				
	Mfg. Part # or Model	Brand	Nice   HySecurity Part #	Max Range	Smart Touch	Smart DC	SmartTouch 725	1050	Mercury 310
Photo Eyes (Retroreflective)	E3K-R10K4-NR-1	Omron	MX000999	40 ft	•	•	•		
	NIR-50-325	EMX		45 ft	•	•	•	•	•
	IRB-RET	EMX		53 ft	•	•	•	•	•
	IRB-RET2	EMX		53	•	•	•	•	•
	E-931-S50RRGQ	Seco-Larm		46 ft	•	•	•		•
	BlueBUS	Nice		30 ft	•	•	•	•	•
Photo Eyes (Through-Beam)	OVS-50TNR	Optex		33 ft	•	•			
	IRB-MON	EMX	MX3990	65 ft	•	•	•		•
	IRB-MON2*	EMX	MX5792-01	65 ft	•	•	•		•
	E-960-D90GQ	Seco-Larm		90 ft	•	•	•		•
	BlueBUS	Nice		65 ft	•	•	•	•	•
Edge Sensors	Sentir Series	ASO Safety	AS1502-** AS1501-**		•	•	•	•	•
	CPT210-2U-#-T2	Miller Edge			•	•	•	•	•
Edge Sensor Converters	Hy2NC (Converts 10K to NC Monitoring)	HySecurity	MX4018		•	•			
	GEM103 (Converts 10K to Pulsed Monitoring)	Miller Edge						•	
Edge, Wireless Kits	iGAZE RE Kit	Transmitter Solutions		50 ft line of sight	•	•	•	•	•
	WEL-200 (kit with receiver and transmitter)	EMX		200 ft line of sight	•	•	•	•	•
	RB-G-K10C	Miller Edge			•	•	•	•	•
Multi-Input Module	The Solution – MIM-62	Miller Edge			•	•	•		•

\* IRB-MON2 photo eyes are pre-bundled with HySecurity SwingSmart DC, SlideSmart DC, and SlideDriver operators.

\*\* Sentir Series ASO edge sensors are pre-bundled with HySecurity SlideSmart DC, and SlideDriver operators.

# Safety Requirements

**Installers must identify all potential entrapment zones and install sensors that protect these areas.**

Review your installation plan for entrapment zones. Install entrapment sensors anywhere within the motion of the gate or gate operator where it has a clearance less than 16 in (41 cm).

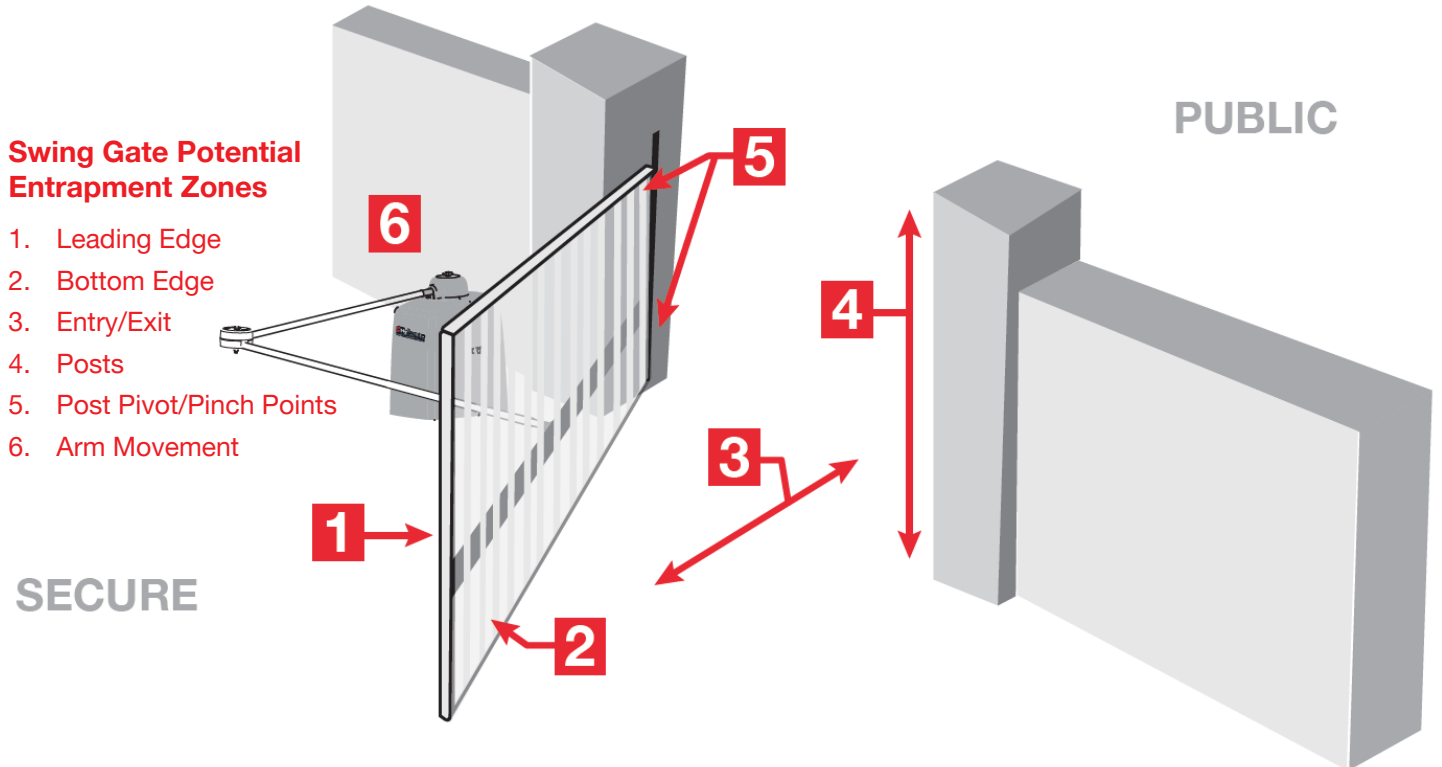

## SWING GATE OPEN POSITION ENTRAPMENT ZONES

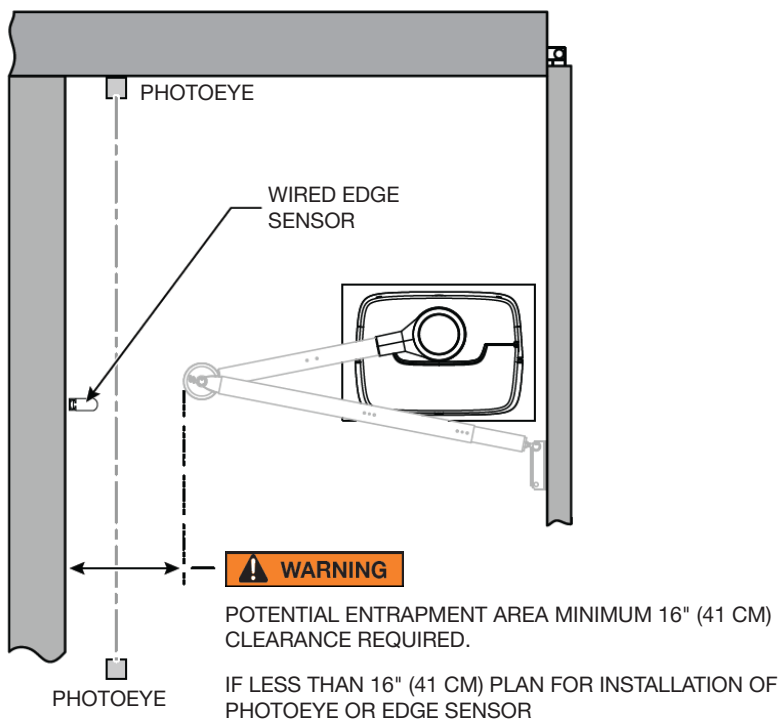

# Safety Requirements

## STOP BUTTON

The stop button clears entrapment mode and resets some faults, errors, and alarms.

The stop button on Smart 535 operators is located on the cover.

Press the stop button while the gate is opening or closing to stop gate travel and disable the automatic close timer. The operator requires a new open or close command to resume function.

Inform all users of the location of the stop button and its function.

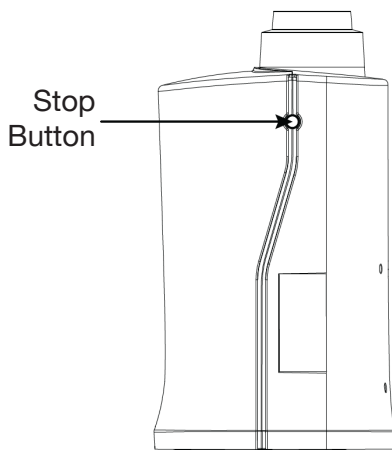

Figure 1. Stop Button

## MANUAL RELEASE

Teach all users how to turn off electric power, loosen the taper clamp, and move the gate manually.

When you set DC power to OFF:

- The motor disengages to stop it from running if an open or close input is activated.
- The Motor Disengaged warning appears on the display.

**To manually open the gate, follow these steps:**

1. Use the key to remove the top cap and the front cover.
2. Set DC power to OFF.
3. Loosen the taper clamp (Figure 2).
4. Swing the gate(s) open or close from the end of the gate.

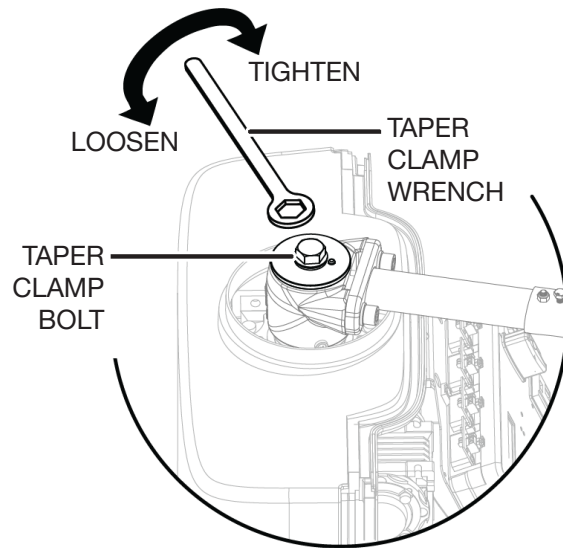

Figure 2. Taper Clamp Bolt and Taper Clamp Wrench

**To return SwingSmart 535 to automatic operation, follow these steps:**

1. Set the taper clamp. Refer to "Set the Taper Clamp" on page 28.
2. Set the DC power switch to ON.
3. Press STOP or RESET to clear any faults.
4. Attach the front cover and top cap.

# Features

## **INTELLIGENT FEATURES: SmartTouch 725™ Controller**

**HySecurity installer smartphone app** for full control from your phone via Bluetooth.

**Save operator configurations** and troubleshoot system via installer smartphone app or USB.

**User Interface – The SmartTouch 725 Controller** manages 70+ configurable items in a simple menu driven interface. The controller includes a library of dozens of solutions for relay logic applications.

**Three configurable user relays plus optional SmartTouch I/O Expansion module** for 8 additional relay outputs.

**OLED display** – A 32-character OLED provides increased readability for programming and troubleshooting.

**Independent adjustment for open and close gate speeds** - An easy-to-use menu on the SmartTouch 725 Controller allows the installer to independently vary the open and close speed settings.

**Intelligent Inherent Entrapment Sensor (IES)** - Any impediment to gate travel is sensed by the system, stopping gate movement per UL 325 Safety Standards. The intelligent system monitors gate power then adapts the IES to trip at an adjustable threshold above normal power.

**Hy5B™ 2.0 vehicle detector** – Four ports for HySecurity Hy5B 2.0 vehicle detectors, enabling advanced features like automatic gate compensation and loop diagnostics.

**Integrated HyNet™ technology** provides remote management capabilities over Ethernet: Securely report gate system status, vehicle tailgating, gate hits, failure to operate, and more, in real time to maintain perimeter security. Additionally, configure email alerts to communicate issues to installer, facility or security responders.

**Compatible with Nice accessories.** OXI MegaCode receiver, ERA and INTI transmitters and BlueBUS photo eyes.

# Unpack the Operator

## UNPACK THE OPERATOR

1. Open the box and remove the front cover, rear cover, photo eye, and ship-with kit.
2. Check the contents of the ship-with kit:
  - a. Basic Manual
  - b. UL 325 required gate safety signs and zip ties
  - c. Taper clamp wrench
  - d. DASMA gate safety literature
  - e. Rear cover mounting hardware
  - f. Cover keys
  - g. Top cap, top cap shield, and zip ties
  - h. Optional 208/230VAC and 24VDC voltage labels
3. Lift operator using the lift handles.

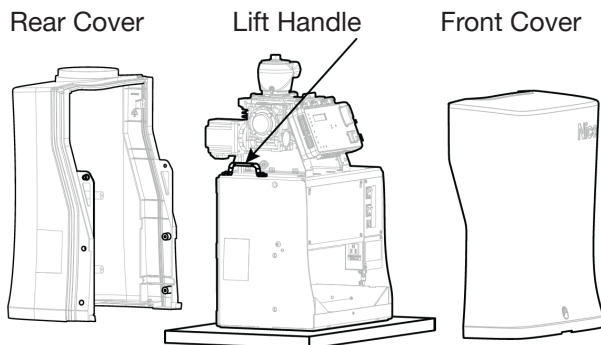

## GENERAL OPERATOR DIMENSIONS

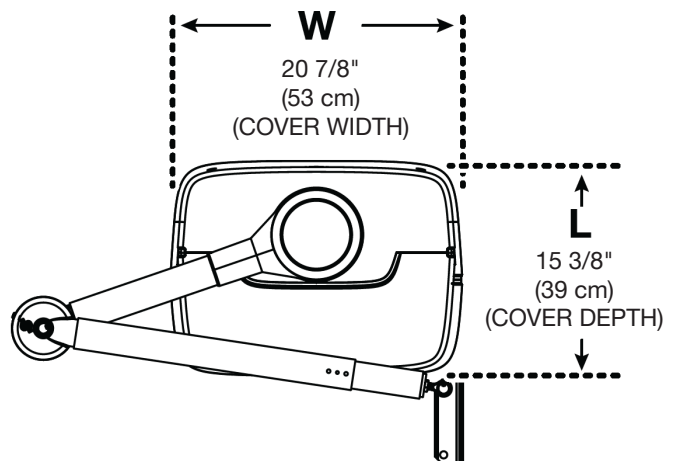
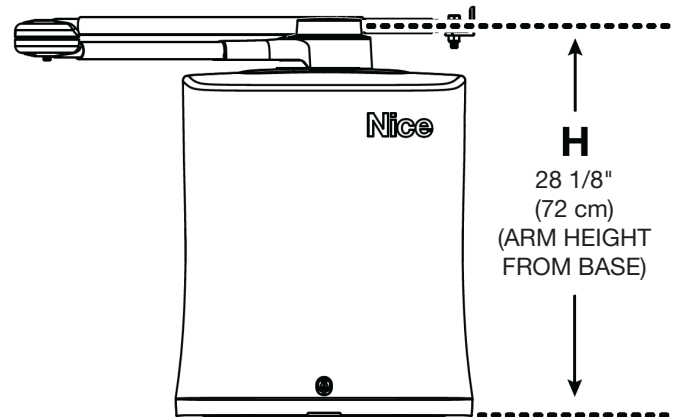

Note: You can mark the slots, conduit area, and output shaft center on the plywood underneath the chassis and then use the plywood as an anchor hole template.

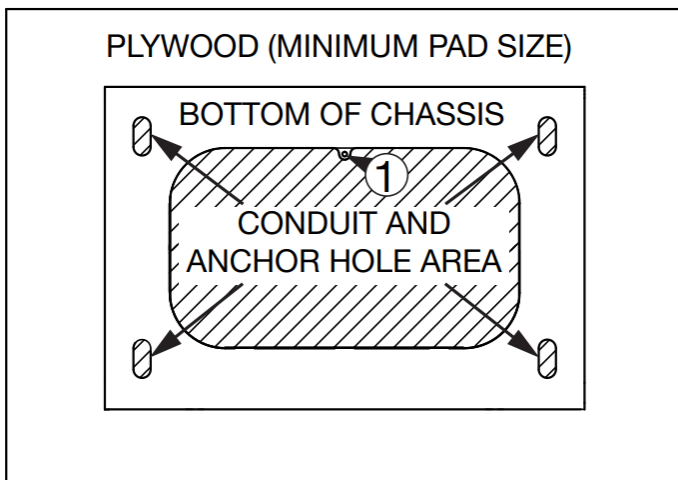

# Operator Position

## NEW INSTALLATION

1. Make sure the pad is completely level before installation.
2. Determine the location of the operator from the gate (Figure 3).
3. Refer to Table 1, Table 2, and the installation site for ideal operator and gate bracket locations.
4. Position the output shaft center at X and Y dimensions from the gate hinge.
5. Refer to Figure 4 for minimum dimensions for a new concrete pad. Refer to Figure 6 for conduit and earth ground requirements.
6. Mark Xg on the gate and mark the anchor hole positions on the concrete pad (Figure 3, Figure 5).
7. Remove the operator and drill holes for four 1/2 inch UNC x 3-1/2 inch wedge style anchors.
8. Install the anchor bolts, mount the operator on the bolts check for level, and shim as necessary.
9. Put a heavy duty flat washer on each bolt and tighten the anchor-bolt nuts.
10. Bury the earth ground rod and connect earth ground wire to the chassis ground lug.

## RETROFIT INSTALLATION

1. Remove any existing operator and anchor bolts.
2. Check the level of the concrete pad and level it if needed.
3. Position the new SwingSmart 535 operator around the conduit.
4. Mark the new anchor locations (Figure 5).
5. Remove the operator and drill holes for four 1/2 inch UNC x 3-1/2 inch wedge style anchors.
6. Install the anchor bolts, mount the operator on the bolts, put a heavy duty flat washer on each bolt, and tighten the anchor-bolt nuts.
7. Measure X and Y from the output shaft center and use Table 3 to calculate Xg, A, and B.
8. Mark Xg on the gate (Figure 3).
9. Route the earth ground wire and connect it to the earth ground lug.

Note: Use these tables as a starting point. Test gate movement and adjust the arm dimensions to achieve proper geometry.

**Table 2. Short/Medium Gate Installation for Gates up to 13 feet (4 meters)**

X	Y	Xg	A	B
12.0 in (30.5 cm)	22.0 in (56 cm)	33.0 in (84 cm)	21.0 in (53 cm)*	28.0 in (71 cm)*
12.0 in (30.5 cm)	24.0 in (61 cm)	35.0 in (89 cm)	22.0 in (56 cm)*	30.0 in (76 cm)*
12.0 in (30.5 cm)	28.0 in (71 cm)	39.0 in (99 cm)	24.5 in (62 cm)*	33.5 in (85 cm)*

\* Section of pivot arm must be cut to achieve geometry. Top cap requires 6 in (15 cm) of smaller diameter tube exposed.

**Table 3. Long Gate Installation for Gates up to 20 feet (6 meters)**

X	Y	Xg	A	B
16.0 in (38 cm)	32.0 in (81 cm)	47.0 in (119 cm)	29.0 in (74 cm)*	40.5 in (103 cm)
16.0 in (38 cm)	36.0 in (91 cm)	51.0 in (130 cm)	32.0 in (81 cm)	43.0 in (109 cm)
16.0 in (38 cm)	40.0 in (102 cm)	56.0 in (142 cm)	35.5 in (90 cm)	46.0 in (117 cm)

\* Section of pivot arm must be cut to achieve geometry. Top cap requires 6 in (15 cm) of smaller diameter tube exposed.

**Table 4. Custom Gate Installation**

X	Y	Xg	A	B
—	—	$X + Y - 1 \text{ in}$	$0.63 \cdot Xg$	$0.87 \cdot Xg$

**Table 5. Operator Placement and Gate Arm Geometry for 100° through 120° opening**

Degree of Swing	X	Y	Xg	A	B
100	20.0 in (51 cm)	24.0 in (61 cm)	43.0 in (109 cm)	31.5 in (80 cm)*	36.0 in (91 cm)
110	26.0 in (66 cm)	24.0 in (61 cm)	43.0 in (109 cm)	32.5 in (83 cm)	40.5 in (103 cm)
120	32.0 in (81 cm)	20.0 in (51 cm)	46.0 in (117 cm)	36.0 in (91 cm)	44.5 in (113 cm)

Maximum A = 38 in (97 cm) and Maximum B = 47 in (121 cm)

# Prepare Installation Site

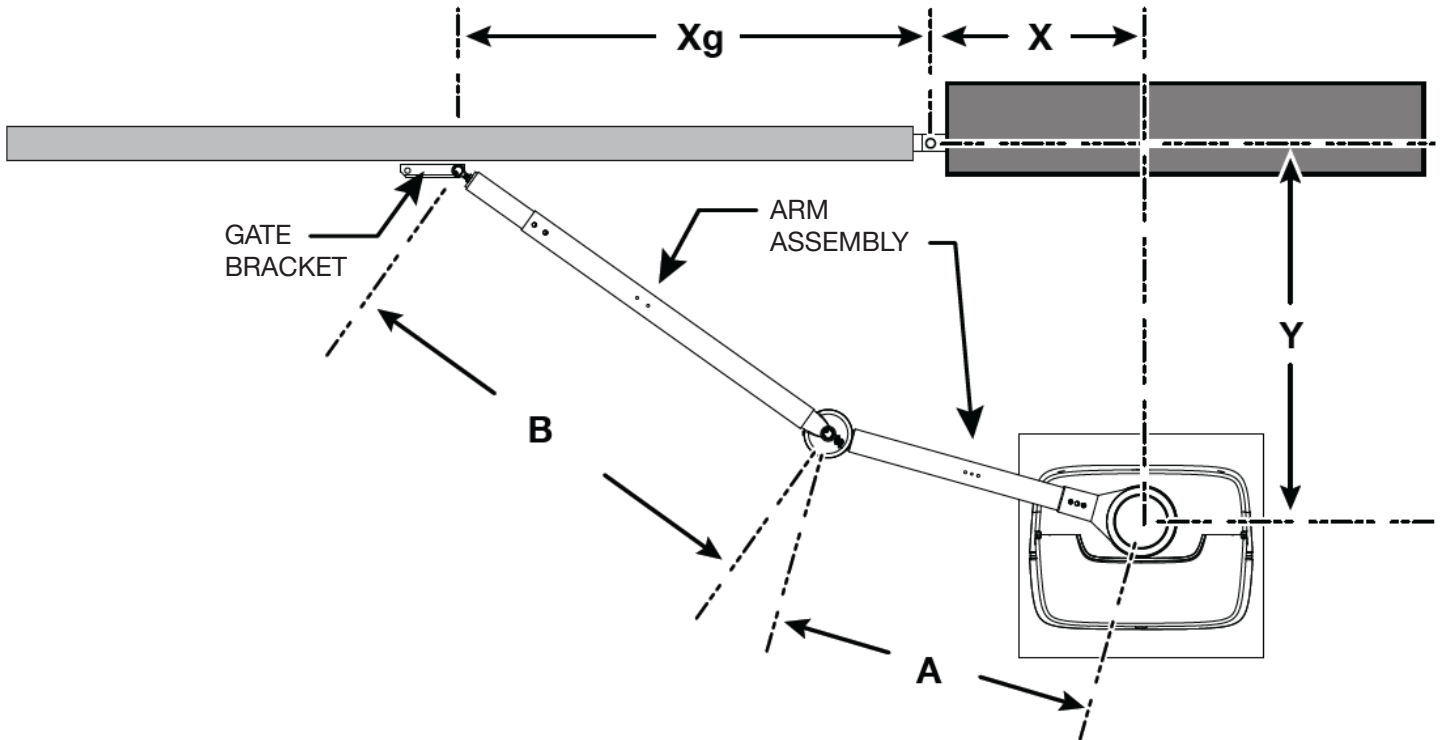

Figure 3. Operator Position Right Hand Opening

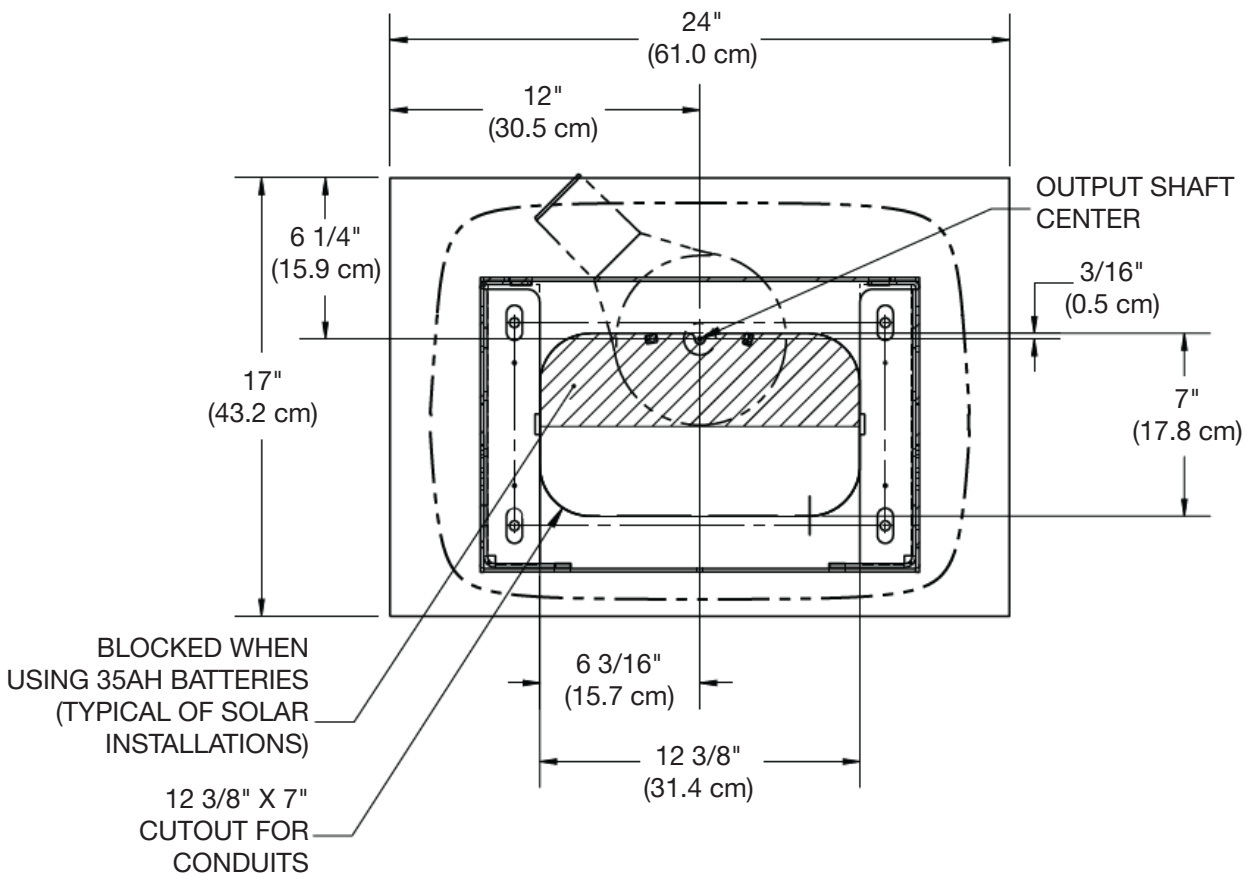

Figure 4. Concrete Pad and Conduit Area Dimensions

# Prepare Installation Site

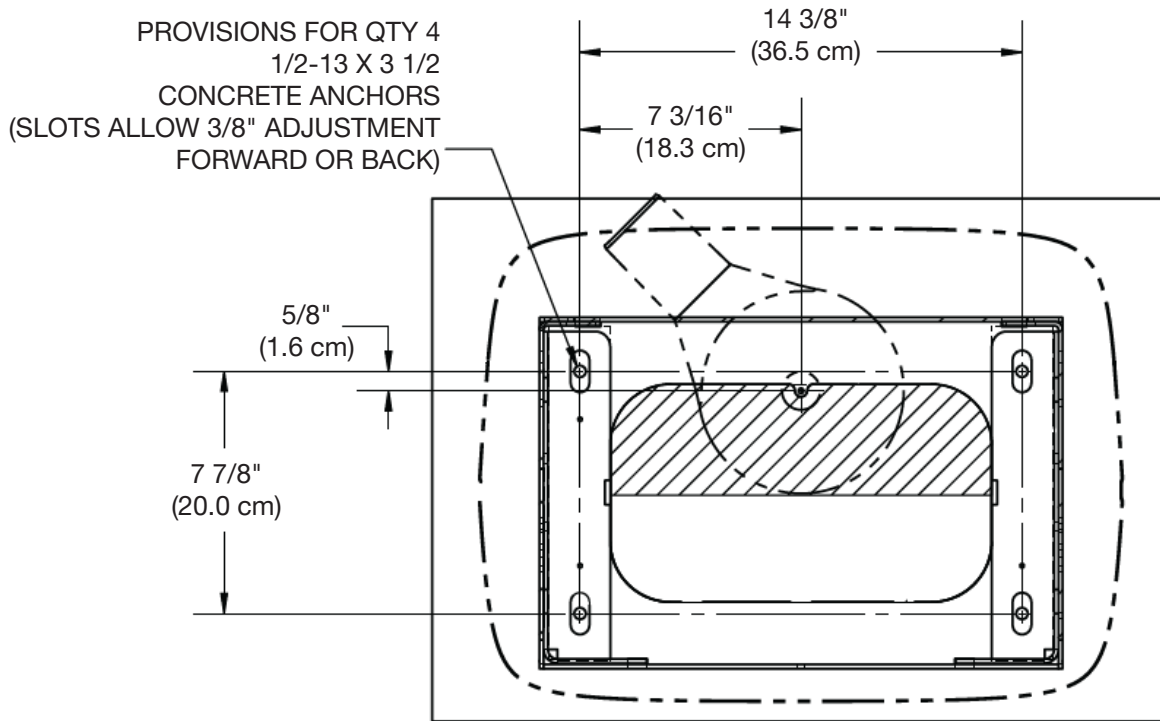

Figure 5. Anchor Hole Dimensions

# Prepare Installation Site

Nice recommends a concrete pad with a minimum 2 inch extension above ground and a pad depth of 16 inches or at least to the frost line, whichever is deeper. Follow local building codes to identify the frost line.



The potential for lightning discharge exists with all gates, fences, and gate operators. National Electric Code (NEC) requires a separate earth ground in addition to the required equipment ground. A local earth ground also serves to protect the electronic controls.

ROUTE 6 AWG  
EARTH GROUND  
WIRE THROUGH  
CONDUIT AND  
ATTACH TO  
PROVIDED  
GROUND LUG

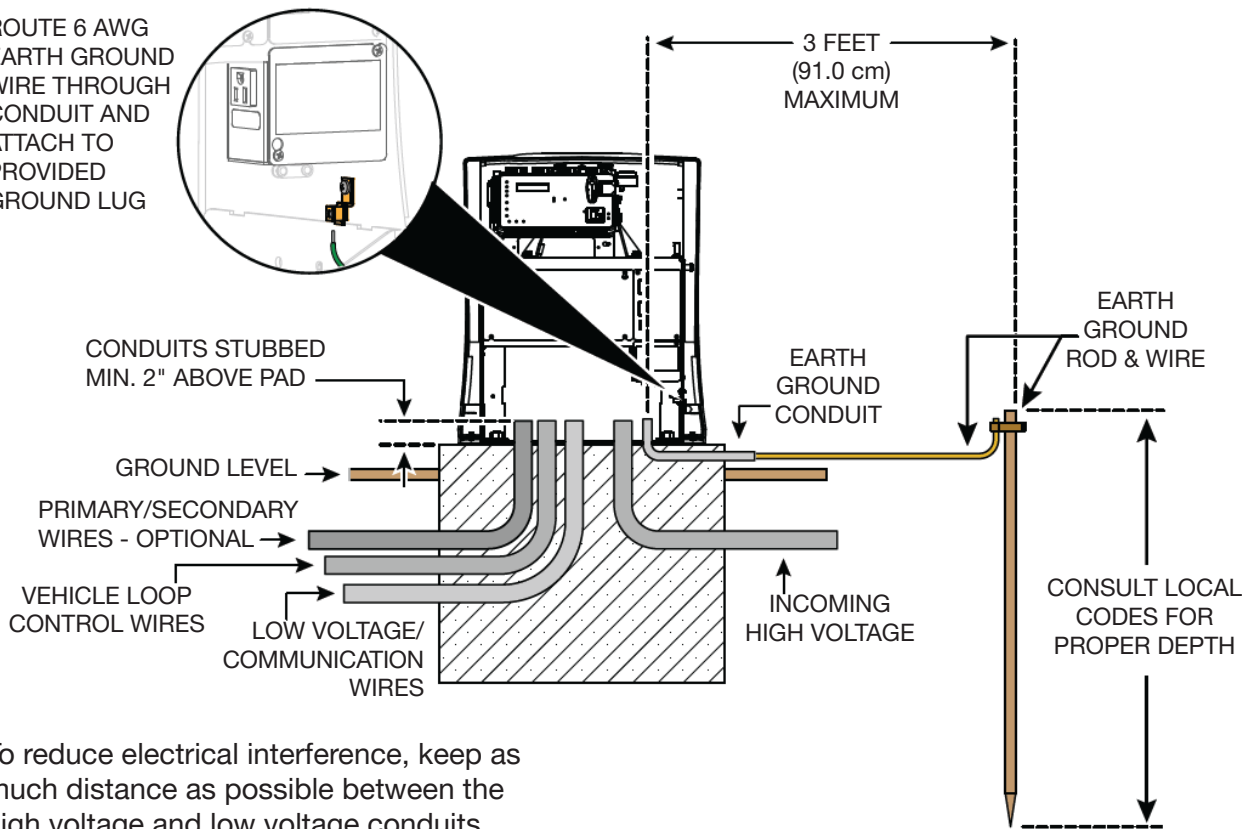

Note: To reduce electrical interference, keep as much distance as possible between the high voltage and low voltage conduits.

Figure 6. Conduits and Earth Ground

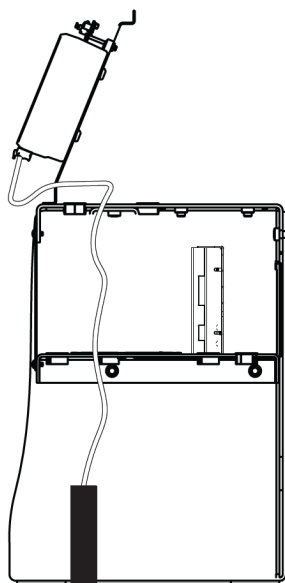
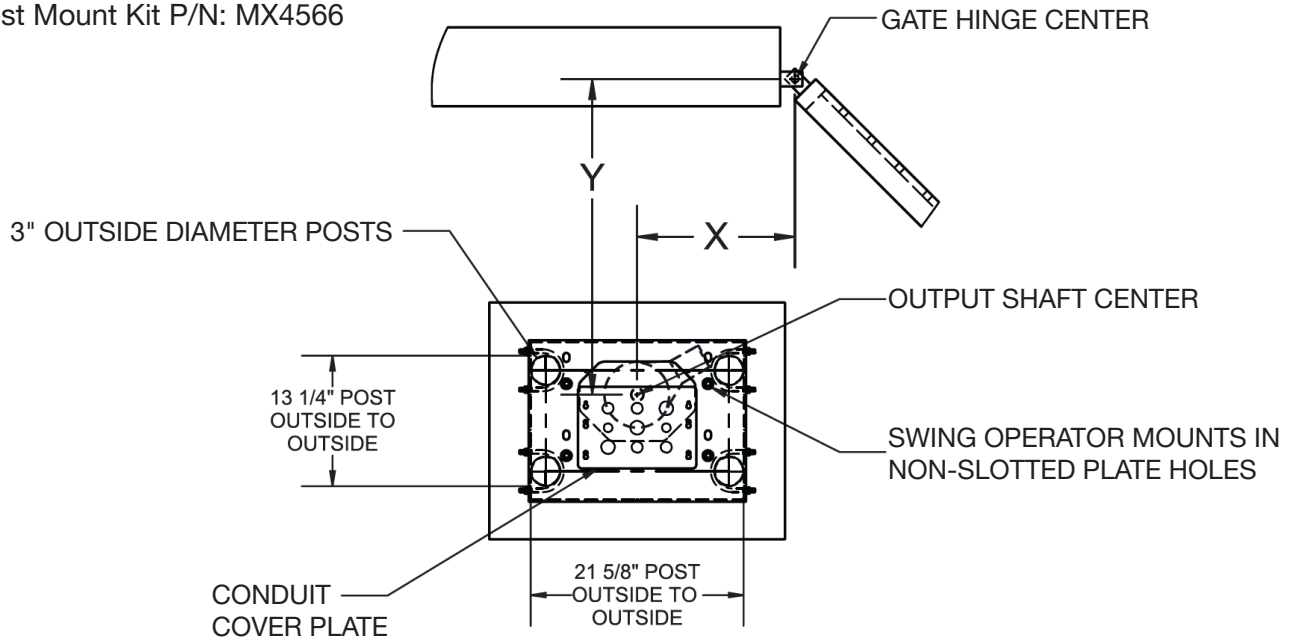

Figure 7. Preferred Control Wire Routing to SmartTouch 725 Controller

# Prepare Installation Site

## 4 INTERNAL POST MOUNT, 3" OD, U-BOLT ATTACHMENT

Note: Post Mount Kit P/N: MX4566



SECTION A-A  
OPERATOR NOT SHOWN FOR CLARITY

Nice RECOMMENDS U-BOLTING AND/OR WELDING POSTS TO MOUNTING PLATE PRIOR TO SECURING IN CONCRETE.

DIMENSIONS X & Y FROM SHEET 1 TABLES APPLY - INCLUDING A, B, AND Xg

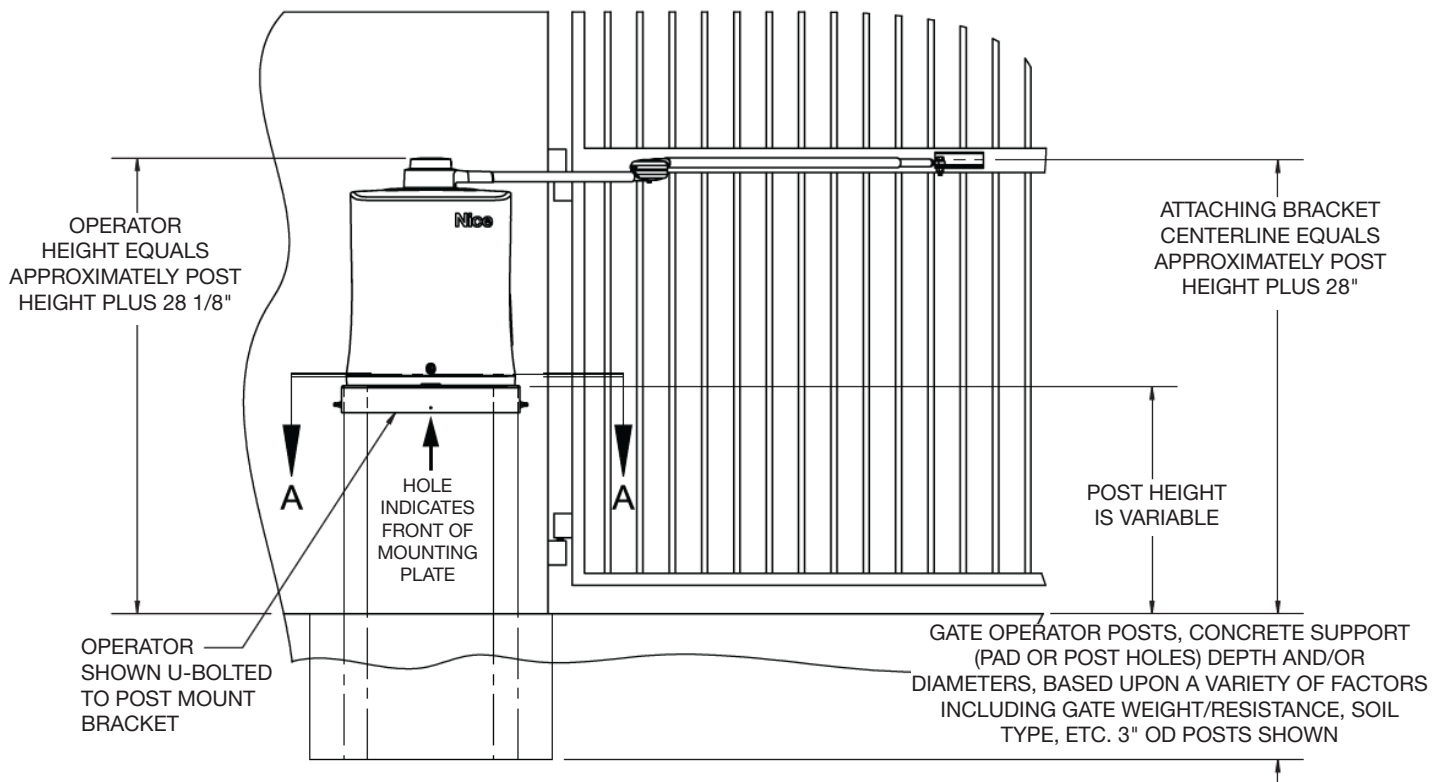

Note: Left hand installation shown. Right Hand installation requires reversing arm L-Bracket attachment end and relocating limit switches.

# Prepare Installation Site

## 4 EXTERNAL POST MOUNT, 3" OD, U-BOLT ATTACHMENT

Note: Post Mount Kit P/N: MX4566

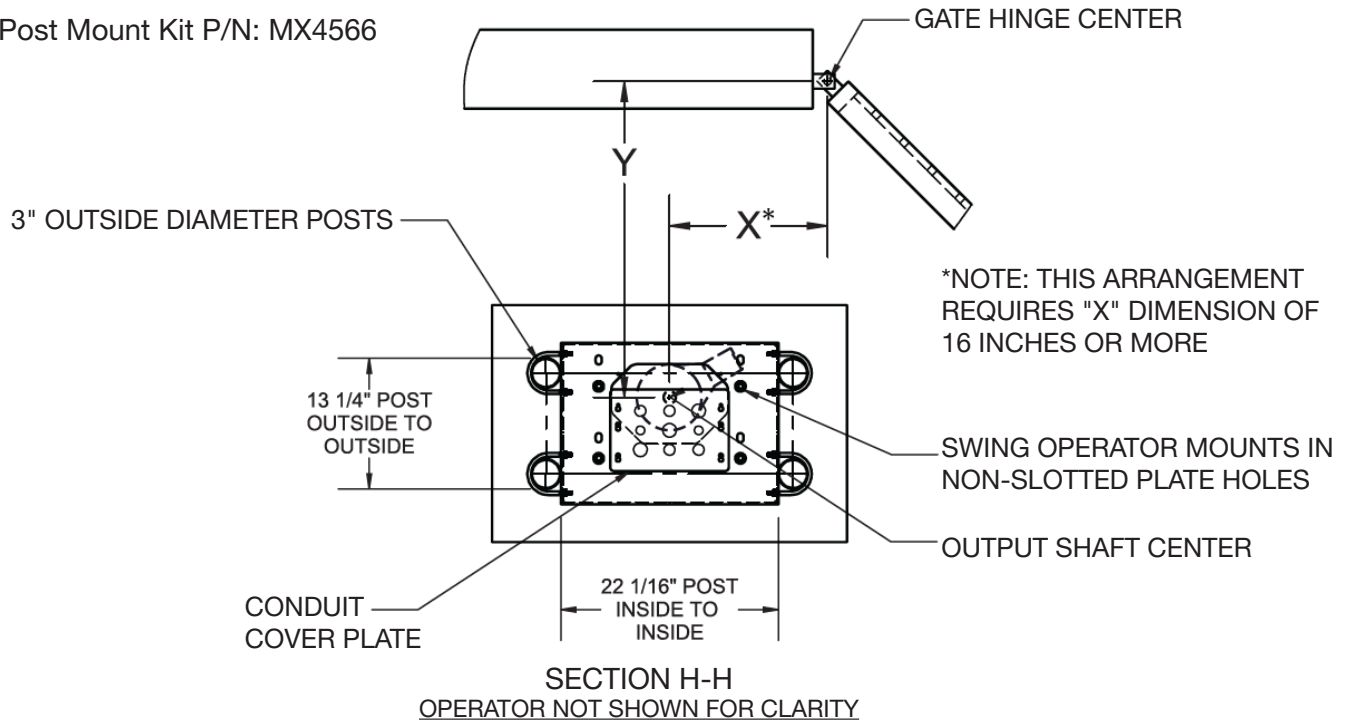

Nice RECOMMENDS U-BOLTING AND/OR WELDING POSTS TO MOUNTING PLATE PRIOR TO SECURING IN CONCRETE.  
 DIMENSIONS X & Y FROM SHEET 1 TABLES APPLY - INCLUDING A, B, AND Xg

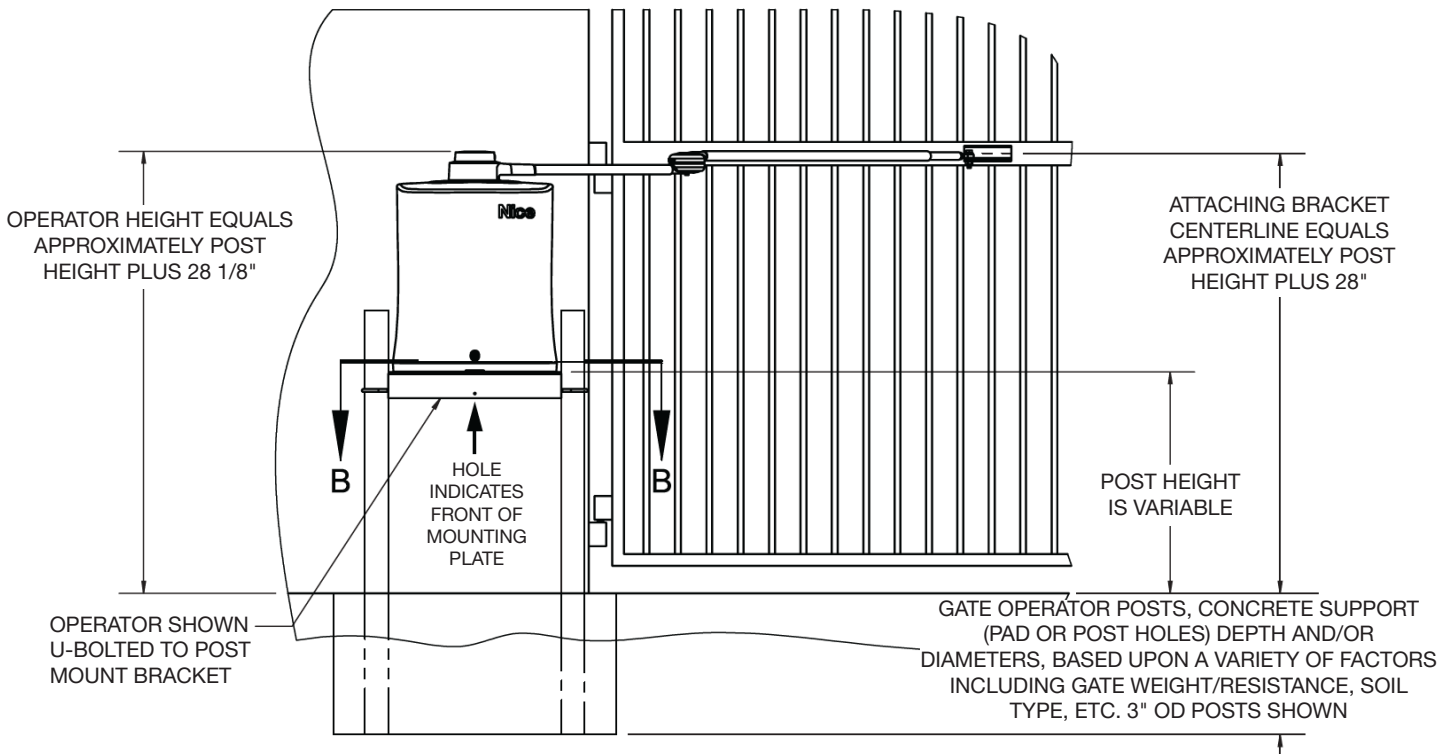

Note: Left hand installation shown. Right hand installation requires reversing arm L-Bracket attachment end and relocating limit switches.

# Prepare Installation Site

## 4 INTERNAL POST MOUNT, 3" OD, WELD ATTACHMENT

Note: Post Mount Kit P/N: MX4566

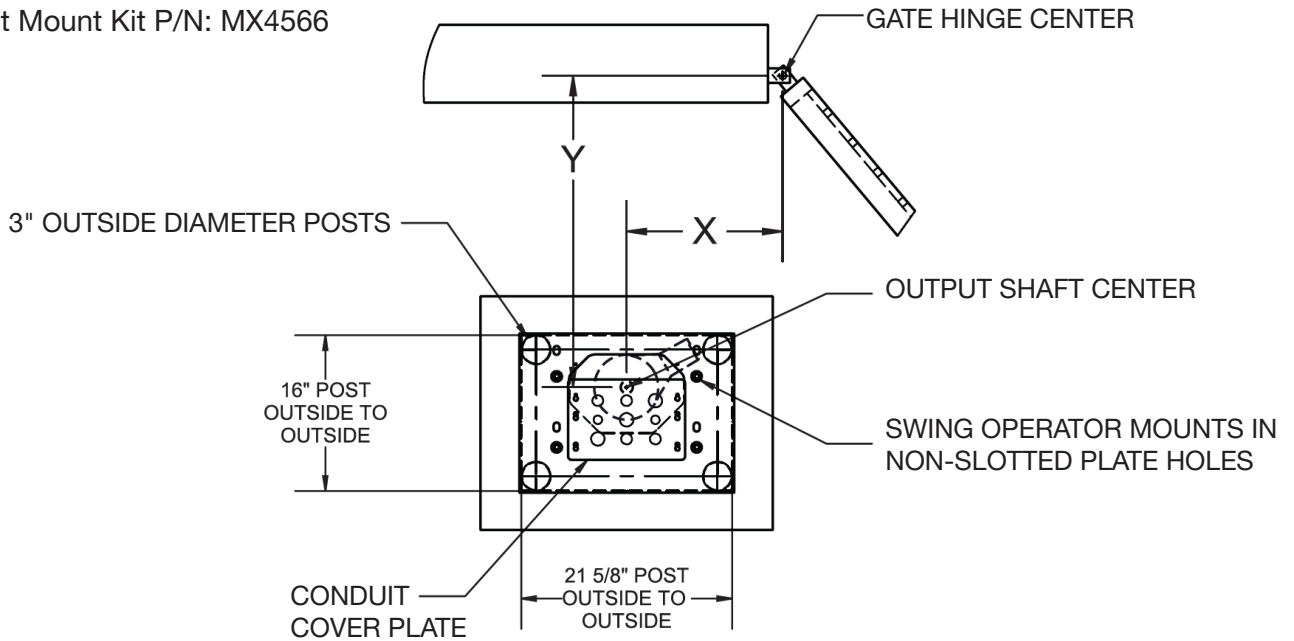

SECTION J-J  
OPERATOR NOT SHOWN FOR CLARITY

Nice RECOMMENDS WELDING POSTS TO MOUNTING PLATE  
PRIOR TO SECURING IN CONCRETE.

DIMENSIONS X & Y FROM SHEET 1 TABLES APPLY - INCLUDING A, B, AND Xg

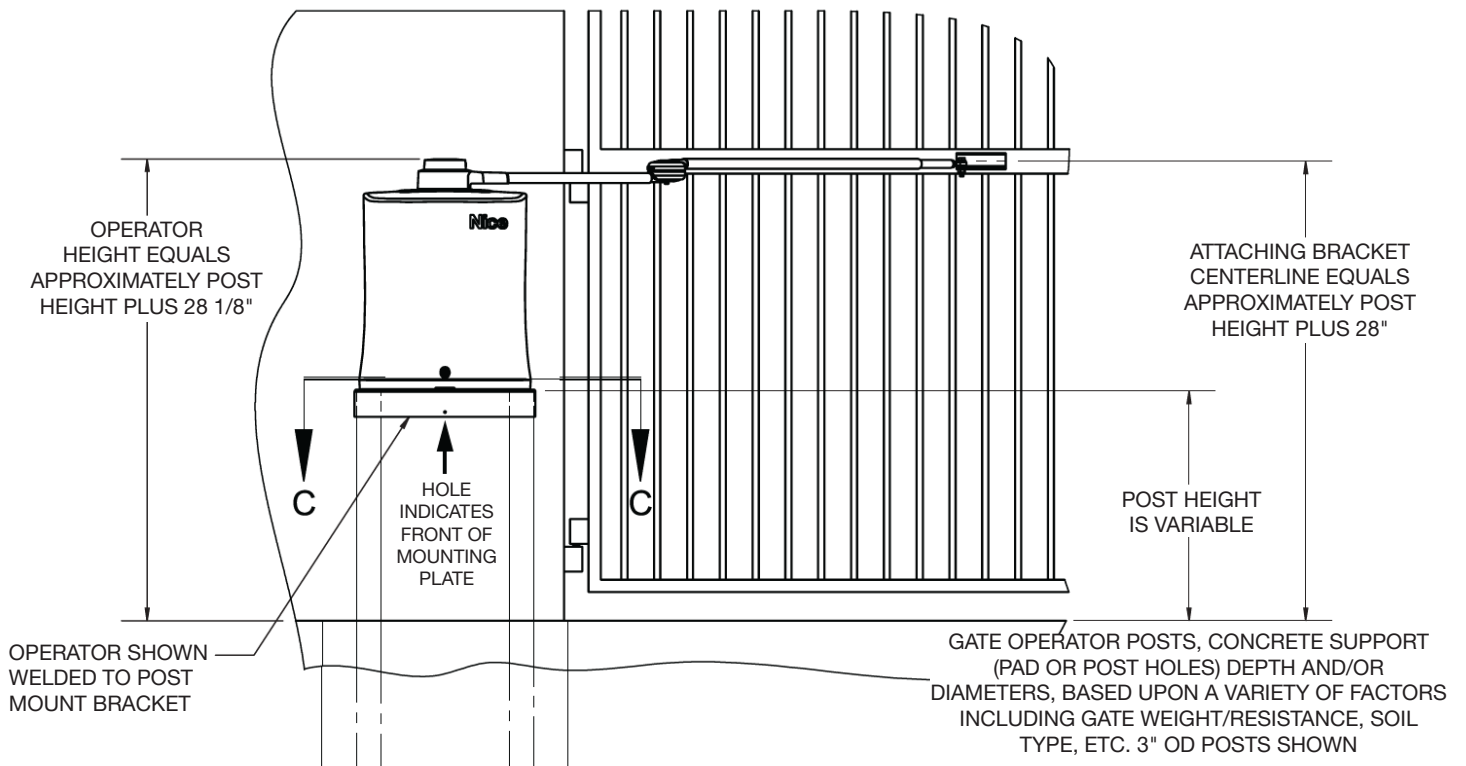

Note: Left hand installation shown. Right hand installation requires reversing arm L-Bracket attachment end and relocating limit switches.

# Install Arm Assembly

1. Set the DC power switch to OFF.
  2. Loosen the taper clamp bolt with the taper clamp wrench (Figure 9).
  3. Attach the operator arm to the taper clamp (Figure 10).
  4. Use Tables 1 through 4 to determine the length of the operator arm (A) and the gate arm (B) (Figure 11).
  5. Loosen the set bolt on each arm and set the arms to length. Tighten the set bolts (Figure 12).
  6. For safety reasons, secure the gate at the closed position to make sure that it does not move.
  7. Position the gate bracket at Xg dimension.
  8. Level the arm assembly.
  9. Move the end of the assembly to Xg and mark the height so the arm assembly stays level (Figure 13).
  10. Clamp the gate bracket at Xg and the marked height (H).
  11. Connect the arm assembly to the gate bracket (Figure 14).
  12. Make sure that the operator arm is below the gate arm (Section B above Section A, Figure 11).
  13. For a bent arm in the closed position, install the set screw in the middle or inner position from the gate. A bent arm in the closed position allows the taper clamp to slip and reduces the risk of damage to the operator in the event of a gate strike (Figure 15 and Figure 16C).
  14. For a straight (locked) arm in the closed position, install the set screw in the outer position from the gate. A straight arm in the closed position increases security, but increases the risk of damage to the operator in the event of a gate strike (Figure 15 and Figure 16D).
- Note: Straighten the arm instead of overtightening the taper clamp for increased security.
15. Manually swing the gate between open and close. Check the arm assembly geometry and clearance with the operator.
  16. Adjust the Xg position or the length of the arms with the set bolts to achieve correct gate geometry (Figure 16A).
  17. Weld or bolt the gate bracket at the final position.

## NOTICE

Top cap installation requires 6 in (15 cm) of exposed length of the small A arm (Figure 11).

18. To set the arm lengths drill 17/64 inch holes through the holes on either side of the set bolts. Then put the 1/4 x 20 bolts through the holes and secure them with the lock nuts (Figure 17).
19. Alternatively, apply a 1/8 inch (3 mm) fillet weld to each seam to permanently set the length of the arm assembly (Figure 17).
20. Remove the set bolts (Figure 12).

## Attach WARNING Signs

**WARNING** Be sure to place the WARNING signs on the gate. For your records, take a photograph of the completed installation site.

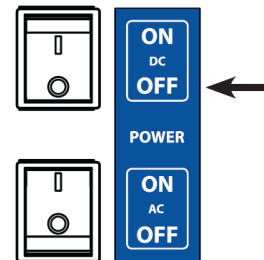

Figure 8. Set the DC Switch to OFF

# Install Arm Assembly

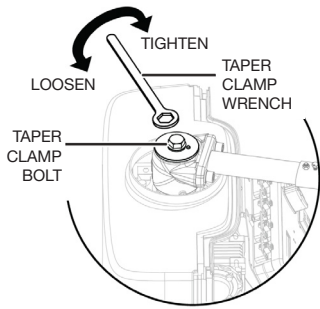

Figure 9. Taper Clamp Bolt and Taper Clamp Wrench

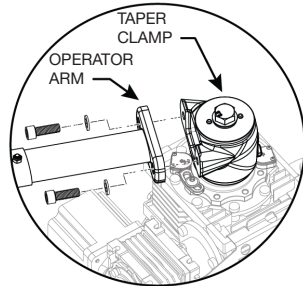

Figure 10. Operator Arm to Taper Clamp

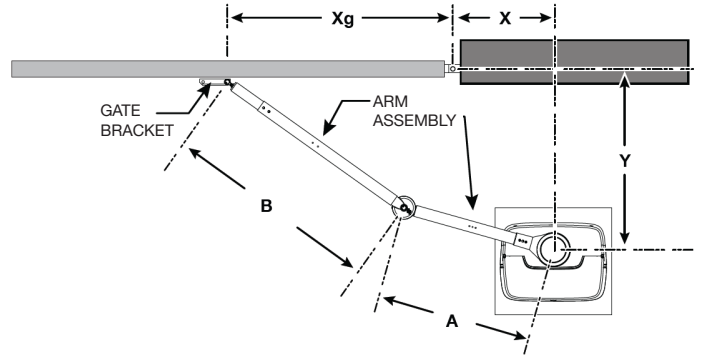

Figure 11. Installation Dimensions

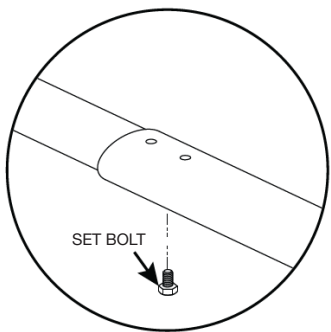

Figure 12. Set Temporary Arm Length

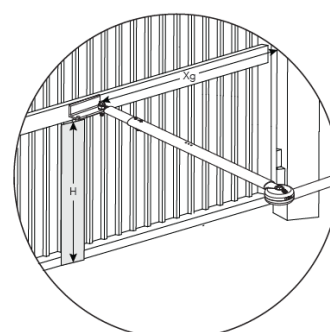
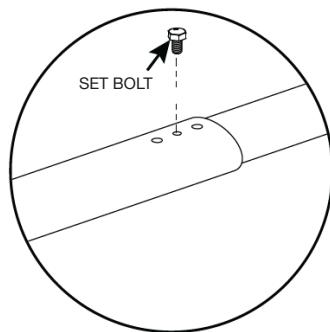

Figure 13. Gate Bracket Height

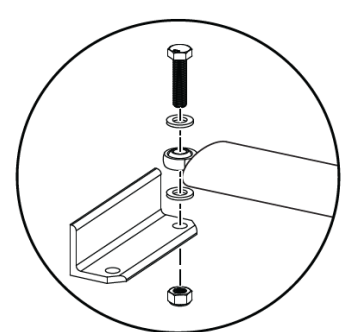

Figure 14. Gate Bracket Hardware

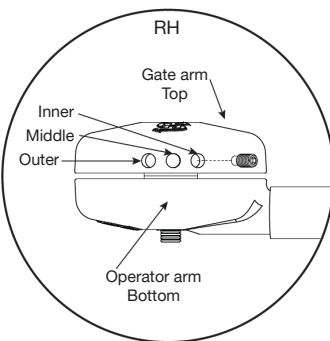
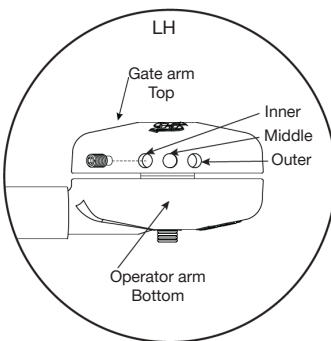

Figure 15. Set Screw Positions

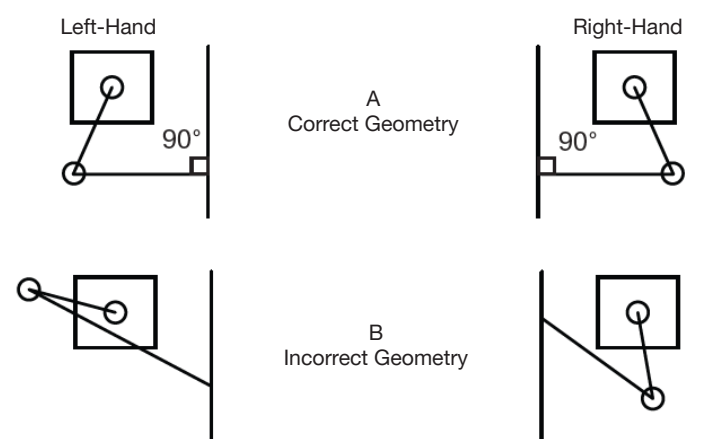

Figure 16. Gate Geometry

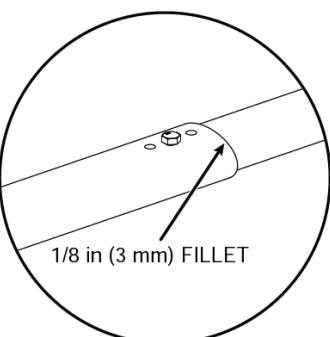
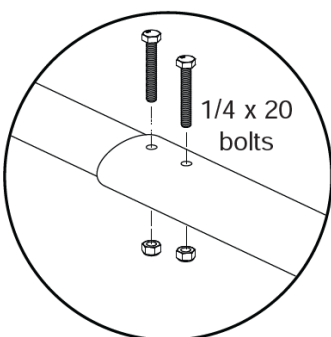

Figure 17. Set Permanent Arm Length

# Install and Adjust the Limit Sensors

The factory default positions of the limit sensor bracket screws are 1 and 5 for LEFT-HAND installation (Figure 18).

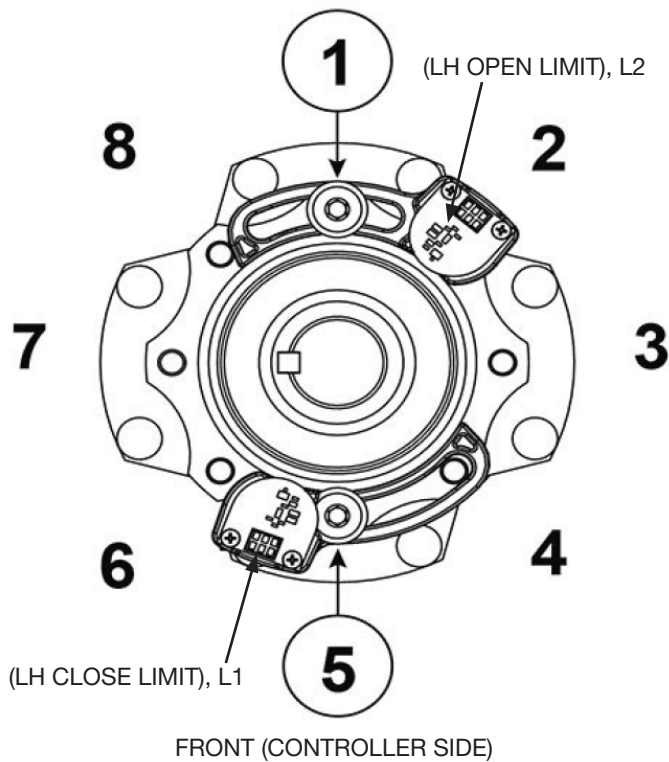

Figure 18. LEFT-HAND Installation

For a Right Hand position, use 5mm Allen wrench and move limit sensor brackets to positions 3 and 7 (Figure 19).

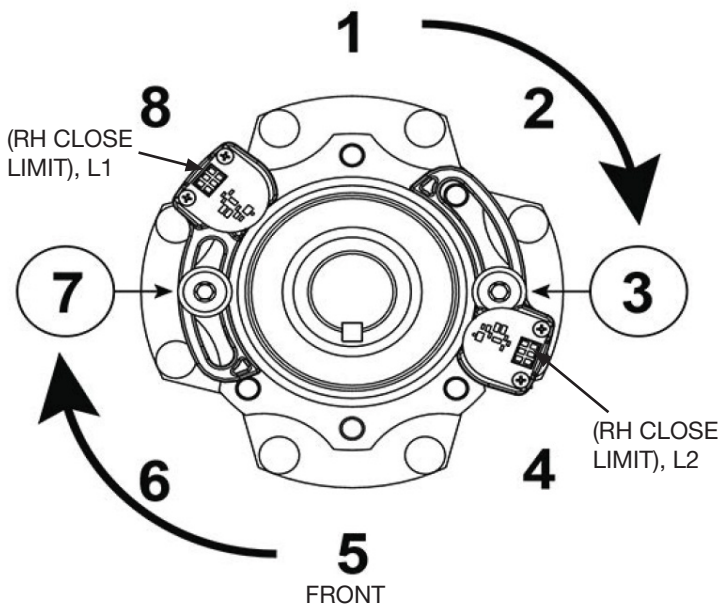
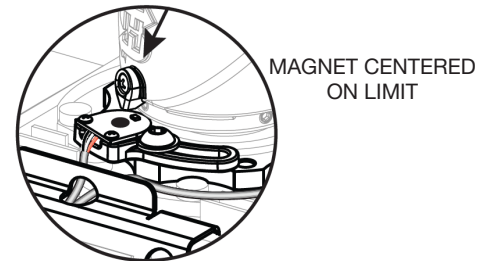

Figure 19. RIGHT-HAND Installation

Note: Some arm geometries will require moving the sensor bracket to the next gearbox hole.

## ADJUST THE LIMIT SENSORS

1. Loosen the taper clamp bolt using the taper bolt wrench to allow the gate and arm assembly to rotate freely (Figure 20).
2. Loosen limit sensor bracket screws using a 5mm Allen wrench (Figure 21).
3. Move the gate to the CLOSED position.
4. Center the CLOSED limit sensor under the target magnet. Hold the limit sensor bracket in place and tighten the bolt.



5. Move the gate to the OPEN position.
6. Center the OPEN limit sensor under the target magnet and tighten the bolt.
7. Manually swing the gate between open and close positions. Verify the appropriate LED (Open or Close) is illuminated on the 725 Controller. Verify at full Open & Close positions there is 1-2" gap between gate and physical stops.

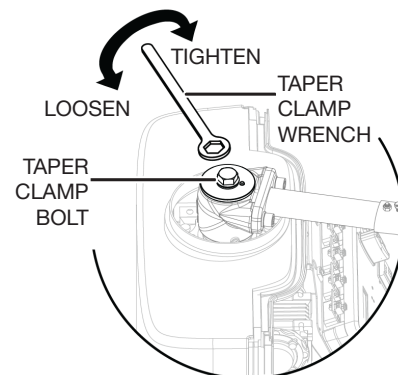

Figure 20. Loosen the Taper Clamp

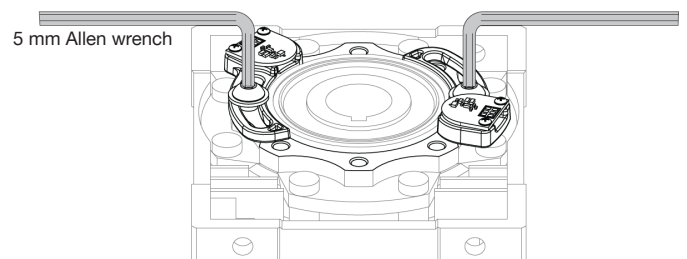
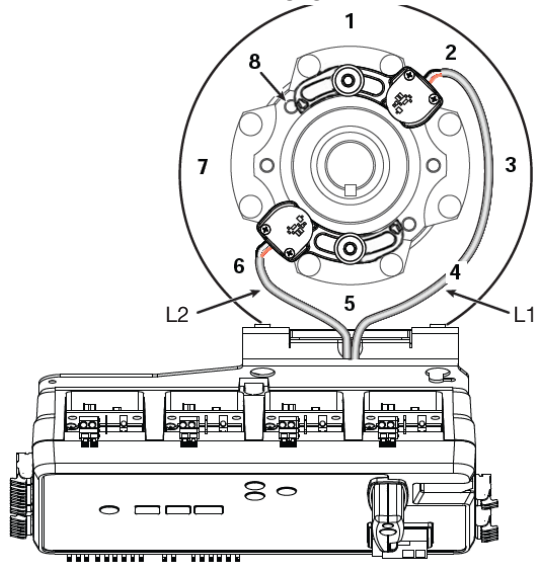

Figure 21. Loosen the Limit Sensor Bracket Bolts

# Install and Adjust the Limit Sensors

LEFT-HAND  
LIMIT SENSOR BRACKETS  
AT 1 & 5



RIGHT-HAND  
LIMIT SENSOR BRACKETS  
AT 3 & 7

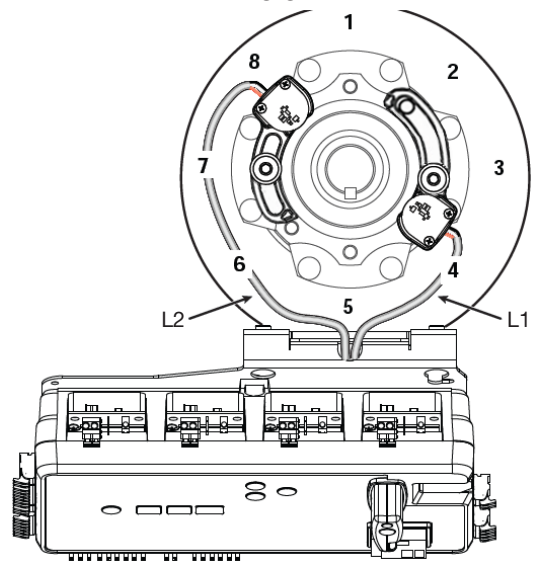

TARGET MAGNET  
AT 5 (CLOSE)

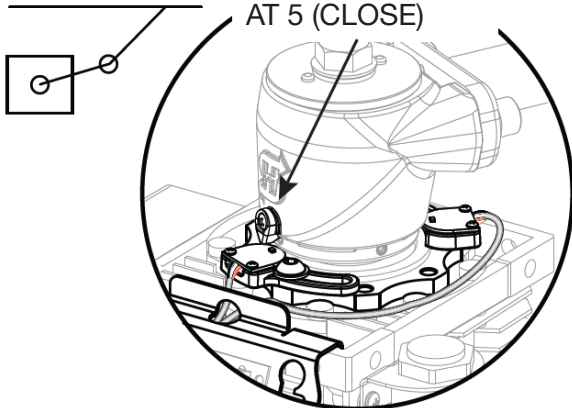

TARGET MAGNET  
AT 3 (CLOSE)

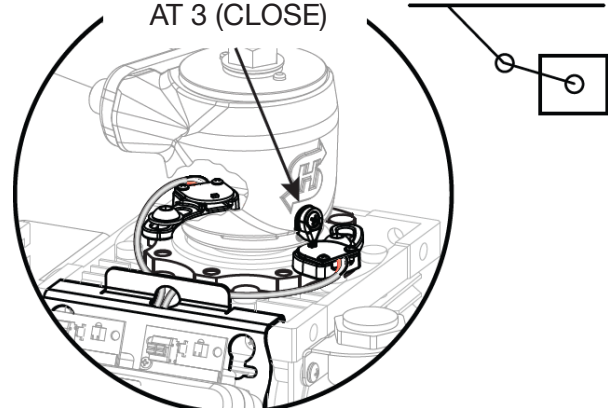

TARGET MAGNET  
AT 1 (OPEN)

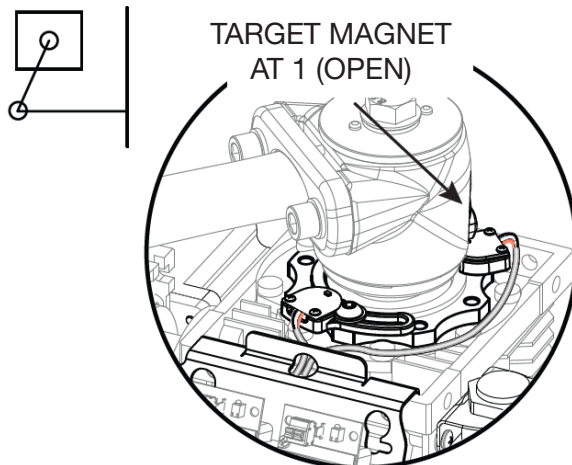

TARGET MAGNET  
AT 7 (OPEN)

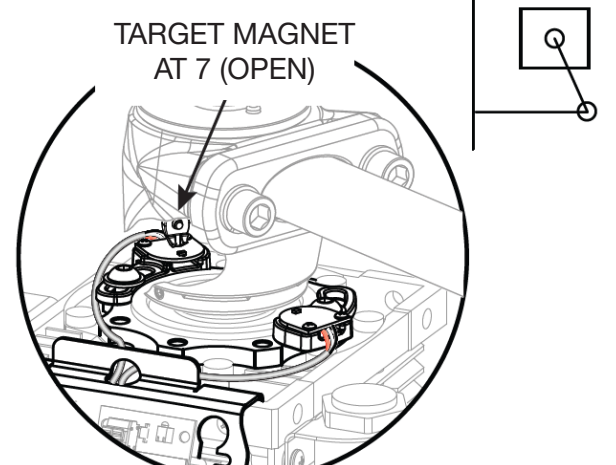

# Attach Back Cover

1. Remove the screws holding the operator arm to the taper clamp (Figure 22) and set the arm assembly to the side.

Note: If the incoming power is 208V/230VAC, refer to page 29 to set the voltage switch on the power supply before attaching the back cover.

2. Set the back cover over the taper clamp (Figure 23).

Note: Make sure that the raised tab on the controller mounting bracket is underneath the gasket groove in the back cover (Figure 24).

3. Install M6 hex bolts at the front cover latch

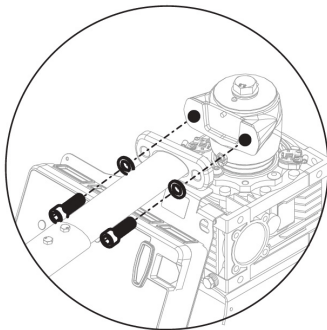

Figure 22. Remove the Operator Arm

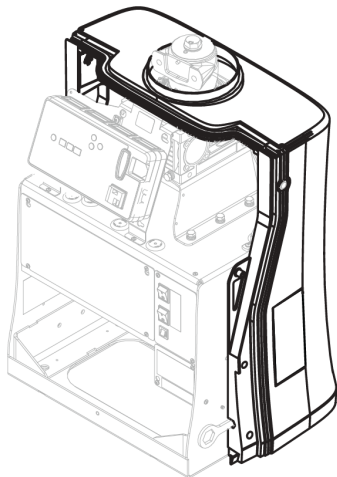

Figure 23. Place the Back Cover

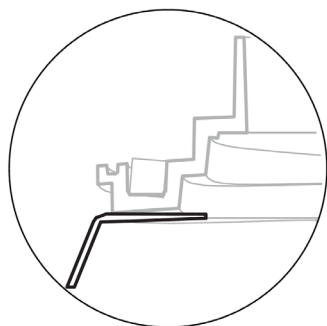

Figure 24. Align Mounting Bracket Tab and Gasket Groove

posts (Figure 25).

Note: Do not over tighten and crush plastic stud.

4. Attach two M5 screws to both sides of the back cover (Figure 26).
5. Attach four M5 screws to the rear of the back cover (Figure 26).
6. Connect wires to stop button (Figure 27).
7. Reattach operator arm and continue to "Adjust Taper Clamp and Attach Top Cap."

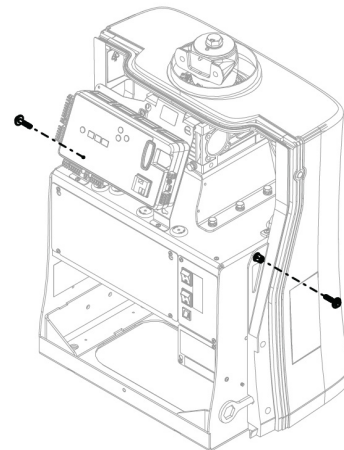

Figure 25. Install M6 Hex Bolts to Latch Posts

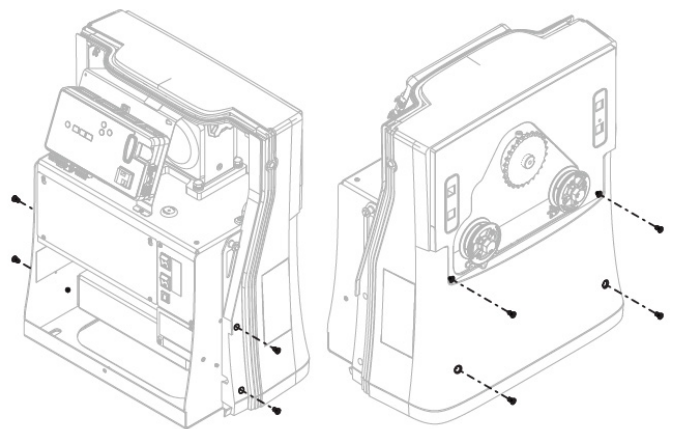

Figure 26. Install M5 Screws to Sides and Back

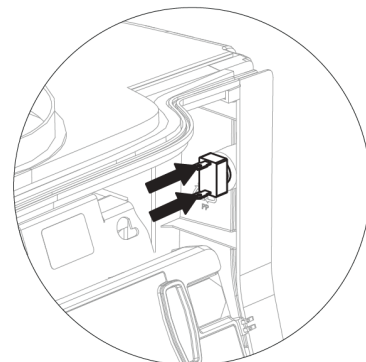

Figure 27. Connect Stop Button

# Adjust Taper Clamp and Attach Top Cap

## FUNCTION OF THE TAPER CLAMP:

The taper clamp will break free in a gate strike, but not slip during normal operation.

If the site requires free flow traffic during installation, wait to tighten the taper clamp until you power and program the operator

## SET THE TAPER CLAMP:

1. Taper clamp wrench is supplied in the ship-with kit and is stored on the right side of the operator chassis (Figure 28).
2. Release the taper clamp by rotating the bolt counterclockwise until it spins freely.
3. Manually swing the gate halfway between the open and close positions.
4. Set the taper clamp by rotating the bolt clockwise until it becomes difficult to turn.
5. To test taper clamp slip, push the end of the gate with 50-75 pounds of force to simulate a gate strike (Figure 29).
6. If the taper clamp slips, turn the taper clamp bolt clockwise an additional 10-15 degrees.
7. Repeat steps 5 and 6 until the taper clamp does not slip below 50 pounds of force and slips easily above 75 pounds during the gate strike simulation.
8. Return the taper clamp wrench to its storage slot.

### **WARNING**

Do not over tighten the taper clamp. An over tight taper clamp could cause damage to the operator during a gate strike or increase the risk of injury or death to pedestrians caught in an entrapment zone.

### **NOTICE**

Do not under tighten the taper clamp, this could cause the taper clamp to slip during normal operation.

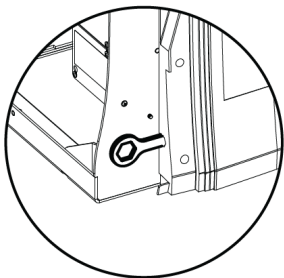

Figure 28. Taper Clamp Wrench Storage

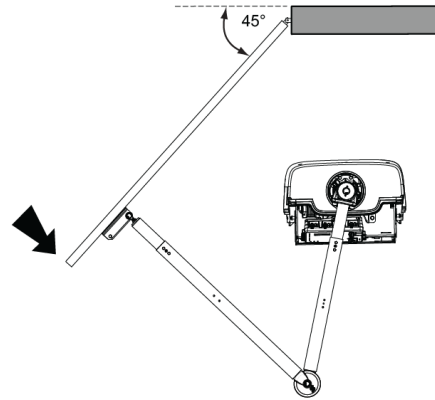

Figure 29. Test the Taper Clamp

## TOP CAP SHIELD:

1. Thread zip ties through slots (Figure 30).
2. Position the top cap shield underneath the operator arm (Figure 31).
3. Secure shield to underside of operator arm with zip ties.
4. Trim the ends of the zip ties (Figure 32).
5. Slide the top cap shield against the opening in the back cover and then pull it away less than 1/8 in (Figure 32).

Zip Tie Channels in the Bottom of the Top Cap Shield

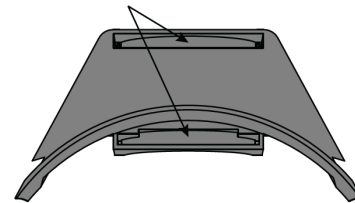
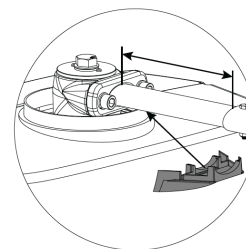

Figure 30. Zip Tie Channels



6 in (15 cm) minimum

Figure 31. Position the Top Cap Shield

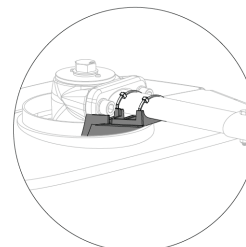

Figure 32. Wrap the Zip Ties Around Arm

# Wiring and Power

## WIRING 115VAC OR 208/230VAC POWER

- Verify AC power supply wires and low voltage accessory wires run through separate conduits. The input voltage to the AC power supply may cause interference and anomalies in SwingSmart 535 operation if the high voltage wires are routed through the same conduit as the low voltage wires.
- Maximum gate operator current draw is 7.5 Amps on a dedicated 115VAC circuit (20A dedicated circuit is recommended).
- Maximum gate operator current draw is 4 Amps on a dedicated 208/230VAC circuit (20A dedicated circuit is recommended).
- Make sure proper wire gauge is used for the length of the wire run. The following tables show the maximum allowable wire run from the power source to the operator for various wire sizes.

Operators are factory set for incoming power of 115VAC. If 208/230VAC, change the voltage switch on the power supply to 230VAC with a flathead screwdriver (Figure 33 and Figure 34).

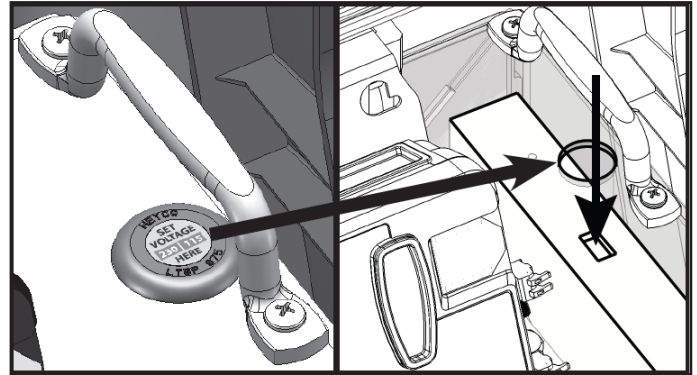

Figure 33. Voltage Switch Access



(Factory Setting)



(Requires Installer Action)

Figure 34. Voltage Switch Positions

Always connect electrical power and ground the operator in accordance with the NFPA 780 & NEC, Article 430 and Article 250. Research and adhere to other local codes that may apply.

### **WARNING**

Applying 208/230VAC power will damage a factory set 115V power supply.

**Table 6. Wire Gauge versus Run**

AC Power	14 gauge wire	12 gauge wire	10 gauge wire
One operator 115V	485 ft (147 m)	775 ft (236 m)	1235 ft (376 m)
Two operators 115V	242 ft (73 m)	387 ft (117 m)	617 ft (188 m)

**Table 7. Wire Gauge versus Run**

AC Power	14 gauge wire	12 gauge wire	10 gauge wire
One operator 208/230V	1375 ft (419 m)	2185 ft (665 m)	3475 ft (1059 m)
Two operators 208/230V	687 ft (209 m)	1092 ft (332 m)	1737 ft (529 m)

## NOTICE

Table 6 and Table 7 assume a dedicated circuit with an accessory power load up to 2A. Additional loads require that the wire size be increased or the distance of the run be decreased.

# Wiring and Power

## **DANGER**

Turn off AC power at the source (circuit breaker panel) before accessing the wires in the operator junction box. Follow facility Lock Out/Tag Out procedures.

1. Make sure both the AC and DC power switches are in the OFF position.
2. Connect the battery harness to the back right hand corner of the drive module. (Figure 35)
3. Remove the junction box cover. (Figure 36)
4. Connect the incoming power supply wires to the AC or DC (solar) terminal block inside the junction box. Match the wire colors (Figure 37).

Note: Remember to set the power supply voltage switch to match 115VAC or 208/230VAC (Figure 34).

5. Organize all the wire connections and put the cover onto the junction box.
6. For solar installations, remove the power switch mounting plate and disconnect the red (+V) and blue (-V) wires from the power supply. Tape or wire nut the ends separately to prevent shorts (Figure 38).

Note: 535 operators require 24VDC rated solar panels with a maximum open circuit voltage of 48VDC.

7. For 208V/230V or solar (24V) installations, place the appropriate label (included in the ship-with kit) over the factory default 115V 1Ø label.
8. Set both AC and DC power switches to ON (Figure 39).
9. Firmware version will appear on LCD display and then the Setup Menu.

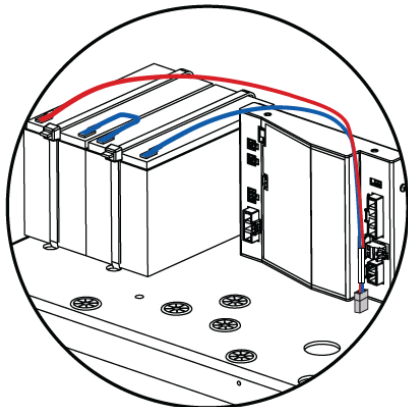
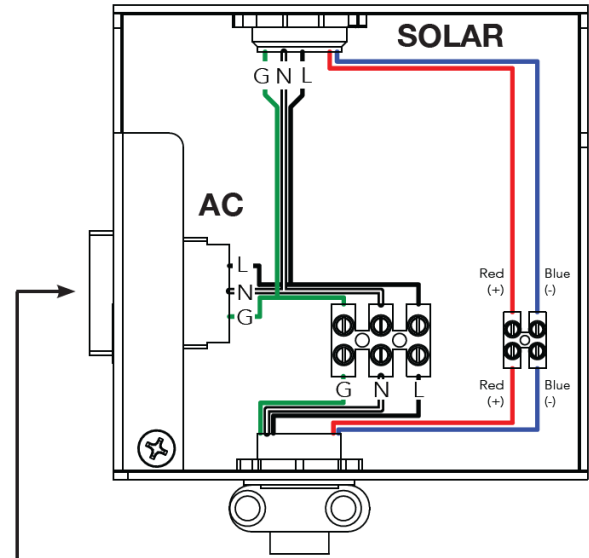

Figure 35. Battery Harness to Drive Module



Figure 36. Junction Box Cover



Connect service outlet lead wires to 115VAC only.

Figure 37. 115VAC/230VAC and Solar DC Terminals

## **WARNING**

Do not connect AC power to the Red and Blue Solar Panel wires.

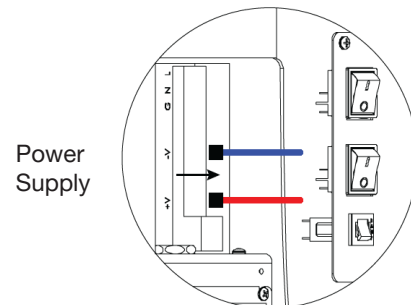

Figure 38. Disconnect DC Power Supply Wires

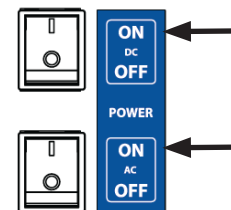

Figure 39. Set both power switches to ON

# Wiring and Power

## LOW VOLTAGE CONTROL WIRING: WIRE GAUGE AND DISTANCE

The SmartTouch 725 Controller has very sensitive control inputs. The following is a chart of maximum distances for wire size:

Wire Size	Maximum Distance
18 AWG	7.0 miles (11 km)
20 AWG	3.5 miles (5.6 km)
22 AWG	2.7 miles (4.3 km)
24 AWG	2.0 miles (3.2 km)
26 AWG	1.0 miles (1.6 km)
28 AWG	3700 feet (1.1 km)

### Other control wiring distances:

BlueBUS 18 AWG	164 feet (50 m)
Dual Gate and Sequenced Gate 18 AWG	0.75 miles (1.2 km)

# Solar Power

## USING A SOLAR POWERED OPERATOR

You can directly connect a 24V solar panel (or two 12V panels in series) to the Smart 535 operators because of the built-in MPPT battery charger.

Solar panels are not included in the purchase of the SwingSmart 535 operators. To plan a solar-powered site, read through this entire section.

HySecurity offers an online Solar Calculator at [www.hysecurity.com/Solar](http://www.hysecurity.com/Solar) that can be used to determine the solar power requirements for your specific gate installation configuration.

## GLOSSARY OF SOLAR POWERED OPERATOR TERMS

**Battery life, aging:** refers to the number of charge and discharge cycles before the batteries need to be replaced.

**Capacity:** refers to how long the batteries can power the operator before a recharge.

**Gate Specs:** refers to the gate weight, length, and open/close speed. Used to roughly determine the energy required to cycle the gate.

## DESIGN REQUIREMENTS & CONSIDERATIONS

Smart 535 operators come with two 8Ah batteries which nominally support up to 1,500 feet of gate travel per day, based on the following:

- 60W (minimum) solar panel system.
- A gate with the following specs: 1000 lbs (454kg), 30 ft (9 m) long, and 1 ft/s (30.5 cm/s) speed.
- Connection of two Hy5B vehicle loop detectors and one multi-code radio receiver.

The following design factors significantly affect the cycle capacity of a solar-powered gate operator and the life of the batteries:

- **Power needs:** Several factors affect the amount of solar power to automate a gate. Some of the most important include:
  - Usage: The number of cycles per day.
  - Gate size: More important for slide gates than swing.

- **Idle power draw:** All systems draw power even when the gate is not moving. Include idle current draw from your operator and accessories. Choose low power accessories when able. Some wireless accessories are battery powered and put no load on the solar system.
- **Available solar power**
  - Plan your system to operate in December, when days are shortest and often cloudy. A solar hours map like the one below depict the power available in kWh/day on a 1m by 1m solar panel in December.
  - Size your panels to provide a little more than daily power used during the worst month of the year.
- **Power storage**
  - The batteries need to power the system for extended times of cloudiness when there will be no solar charging. Take the daily power needed and multiply by the desired backup power duration. Size the batteries to have about twice the needed power. This prevents deep cycling the batteries, which reduces their life. For 24V systems always use two batteries of the same size wired in series.
- **Other considerations**
  - Select low power accessories when possible.
  - Locate solar panels for full sunlight. Avoid shade and other obstructions
  - Assume greater power usage during calculations.
  - For additional resources including an online calculator, more detailed planning sheets, and other resources go to: [HySecurity.com/solarsolarelectricityhandbook.com](http://HySecurity.com/solarsolarelectricityhandbook.com)
  - Gate cycle frequency. As the peripherals draw power from the batteries the cycle capacity goes down. An operator that cycles constantly is most likely to achieve maximum cycles from battery power.
  - Extreme temperatures reduce battery capacity and accelerate aging. Keep the batteries away from temperatures above 90°F (32C).
  - Good gate hardware and smooth, unobstructed gate travel lower the operator's power draw and serve to extend battery life.

# Solar Power

## CONNECTING THE SWINGSMART 535 TO A SOLAR PANEL SYSTEM

1. Install one 24VDC solar panel or two 12VDC solar panels in series with a total capacity of at least 60W (Figure 40). Mount them according to the manufacturer's installation instructions within 100 ft of the operator. Check NEC and local regulations for other distances that may apply.
2. Set both AC and DC switches on the operator to OFF.
3. Remove the power switch mounting plate and disconnect the DC wires from the power supply. Tape or wire nut the ends separately to prevent shorts (Figure 38).

### NOTICE

There is a risk of damage to electrical components is working on them while the solar panels are energized. Disconnect or disable the solar panels before working with the electrical components.

4. Connect any earth ground wires from the solar panels to the operator chassis ground (Figure 6 on page 19).
5. Connect the solar panel wires to the solar terminal block with matching polarity. Use 14 gauge wire or larger (Figure 37 on page 30).
6. Set AC and DC switches on the operator to ON. Continue to "Initial Set Up" on page 39.

## CONNECTING PERIPHERALS TO SOLAR OPERATORS

To connect any peripheral devices to a solar operator, use the 24VDC terminals. Because a solar operator gets its energy from the sun and stores the energy produced by the solar panels in batteries that are constantly discharging, it is important to use peripheral devices that draw and consume as little power as possible.

HySecurity recommends the Hy5B vehicle detector for solar powered sites that require vehicle detectors. The Hy5B draws a minimal 0.005A per detector. Box detectors usually draw much more current.

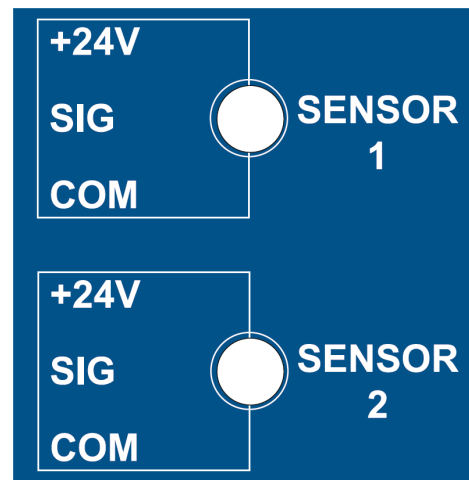

Figure 41. Solar Peripheral Connections

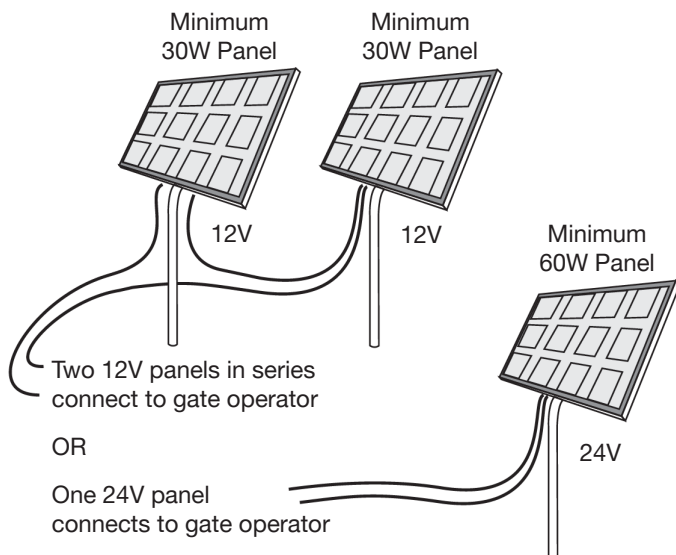

Figure 40. Minimum Solar Panel Configuration

# Solar Power

## UNDERSTANDING GATE ACTIVITY BASED ON SOLAR ZONES

Use the solar maps to determine the number of solar hours per day that can be reasonably expected in a particular zone. The number of solar hours per day affects the amount of gate travel for a free-moving gate powered by the SwingSmart 535 solar operator. See Figure 42.

The chart is based on a 60 Watt (24VDC) solar panel system with SwingSmart powering a 12 foot (3.6 m), 750 lbs (340kg) gate with the following peripherals attached:

- One low current multi-code radio receiver (50mA)
- Two HY-5B vehicle detectors (100mA)
- One monitored photo eye

The number of amps that the peripherals draw coupled with the gate travel occurring throughout the night determines the battery capacity required. Overcast weather increases required battery capacity.

The number of amps that the peripherals draw coupled with the gate travel during the day, determines the solar panel size needed.

Note: HySecurity provides a 35Ah battery option for sites where high gate travel and inclement weather are an issue. For sites of this nature, consider at least a 120W system. A 120W system doubles the feet of gate travel/day that is shown in the chart below.

### NOTICE

Remember, the sun is the only source of energy. If you need to increase the amount of gate travel per day (i.e. feet of gate travel), additional solar panels may be required. The greater the battery capacity, the longer the operator can cycle the gate on cloudy days without the recharge provided by the solar panels. Sites requiring more feet of gate travel per day, or those sites located in less sunny locations, need larger capacity batteries and larger solar panels. HySecurity offers a 35Ah battery option which provides 4 times the storage capacity of the standard 8Ah batteries.

### Map Legend

Solar hrs/day	Cycles/day with 35Ah batteries
5.0	200 (60W panel)
4.5	150 (60W panel)
4.0	100 (60W panel)
3.5	60 (60W panel)
3.0	10 (60W panel)

Note: Hawaii not shown. Assume solar hours per day in Hawaii is same as Arizona.

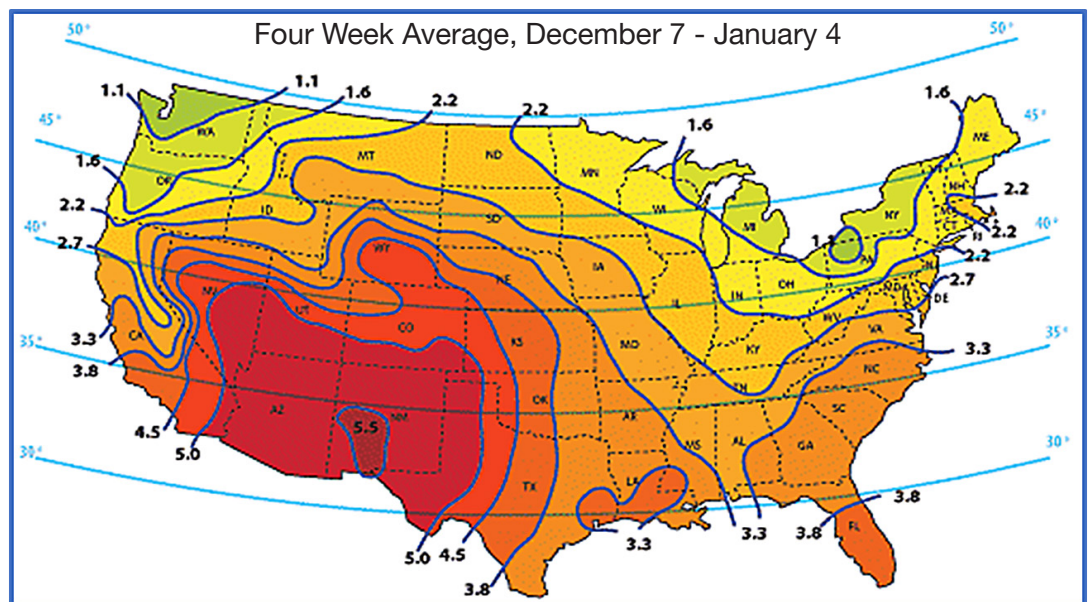

For up-to-date solar isolation maps, refer to <http://www.nrel.gov/gis/solar.html>

This solar isolation map recreated courtesy DOE.

Figure 42. Solar Legend Map

# Solar Power

## IMPORTANT CONSIDERATIONS FOR BATTERY POWERED OPERATORS

- Since the operator is intended to run on batteries, control of the load is important. Gates that move easily and do not bind will drain less energy from the battery, preserving capacity for more cycles during a power failure.
- Be certain to observe polarity when connecting the batteries or adding accessories. Reversed polarity may result in a non-functional operator or damage to a component. Red (+) is positive and black (-) is negative.
- If shorted, the batteries will generate a very high current.
- The batteries are connected in series. Connect the red harness wire to the red terminal on left battery. Connect the black harness wire to the black terminal on the right battery. Connect the blue jumper wire between the batteries.
- Batteries have a finite life and age more quickly when exposed to temperatures above 80°F (27°C). Battery temperatures above 104°F (40°C) are damaging and significantly shorten battery life.

**Table 8. Battery Lifespan and Average Operating Temperature**

Average Temperature	Battery Lifespan
80°F (27°C)	100%
90°F (32°C)	50%
104°F (40°C)	25%

- As the batteries age, they will progressively lose their capacity to store energy. If the total amount of back up capacity is critical, plan to replace the batteries after two years of use especially in hot climates. Properly discard used batteries. Refer to Hazardous Materials and Proper Disposal.

### WARNING

Batteries contain sulfuric acid. Acid in your eyes, on your skin, or on your clothing can cause injury and severe burns. If batteries are dropped or damaged dispose of them properly.

- Batteries are rated to perform to capacity at certain temperatures. Variations in temperature affect performance of the batteries. An example of amp hour performance is shown in Table 8.

**Table 9. Battery Capacity and Temperature During Operation**

Temperature	Capacity
77°F (25°C)	100%
32°F (0°C)	80%
-22°F (-27°C)	50%

- HySecurity uses a sealed AGM-type battery which lasts much longer than wet cell batteries and needs no maintenance over its life span. The charger circuit regulates to allow high charger output when the battery is partially discharged. The charger circuit automatically reduces the output to near zero as the batteries become fully charged. The charger circuit compensates for temperature fluctuations to optimize battery performance.

### NOTICE

The SwingSmart 535 operator stores all menu settings in non-volatile memory. Configurations are saved if a power loss occurs, and reinstated once power is restored.

# Extended Battery Kit

## INSTALL EXTENDED BATTERY KIT

Note: Kit, 35Ah Batteries P/N MX4490

1. Remove the front cover.
2. Set the AC and DC switches to OFF.
3. Remove the wiring access panel.
4. Remove the zip ties and wire harness from the 8Ah batteries.
5. Remove the 8Ah batteries.
6. Install the extended battery tray at the back of the conduit cut out. (Figure 43)
7. Place the 35Ah batteries on the tray. (Figure 44)
8. Connect the adjacent red (+) and black (-) terminals with the blue wire in the 35Ah wire harness.
9. Connect the red and black wires in the 35Ah wire harness to the matching battery terminals (red – red and black – black).
10. Connect the 35Ah wire harness to the 8Ah wire harness (red – red and black – blue) (Figure 45).
11. Install the access panel.
12. Set the AC and DC switches to ON.
13. Set the BATTERY TYPE to 1 (EXTENDED) in the menus. MENU > OPERATOR CONFIGURATIONS > BATTERY TYPE > 1 (EXTENDED) > SELECT > exit menus.
14. Install the front cover.

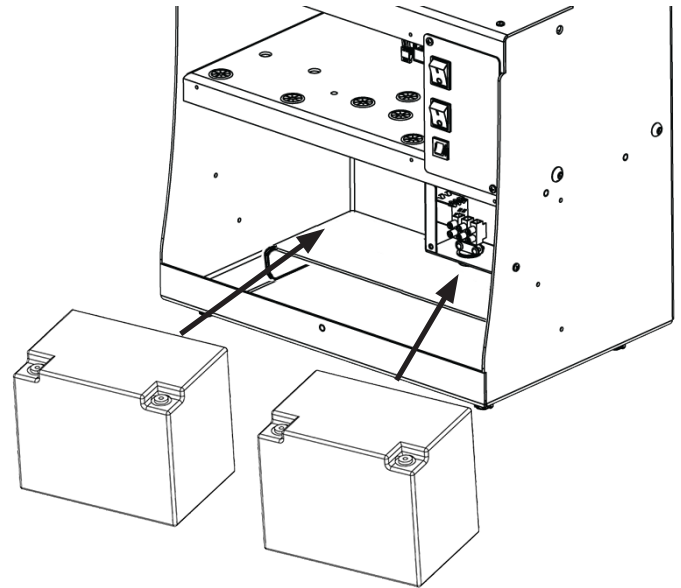

Figure 44. Installed Extended Batteries

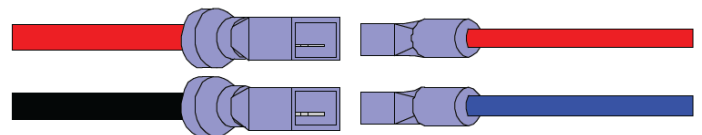
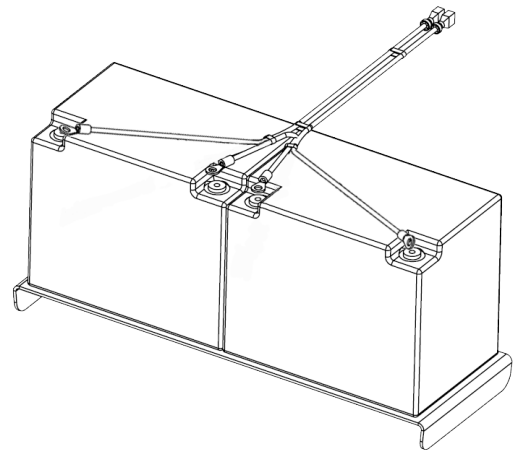

Figure 45. 35Ah Wire Harness to 8Ah Wire Harness

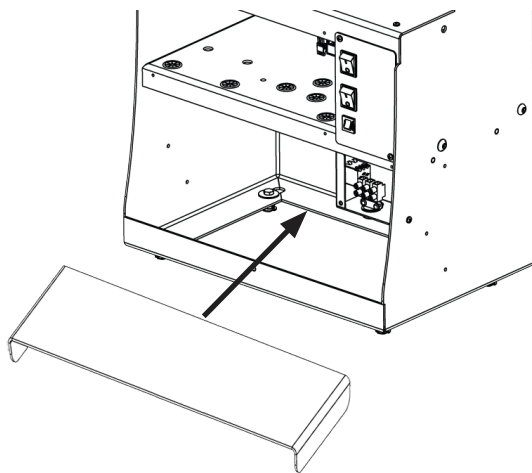

Figure 43. Install Extended Battery Tray

# Controller Connections

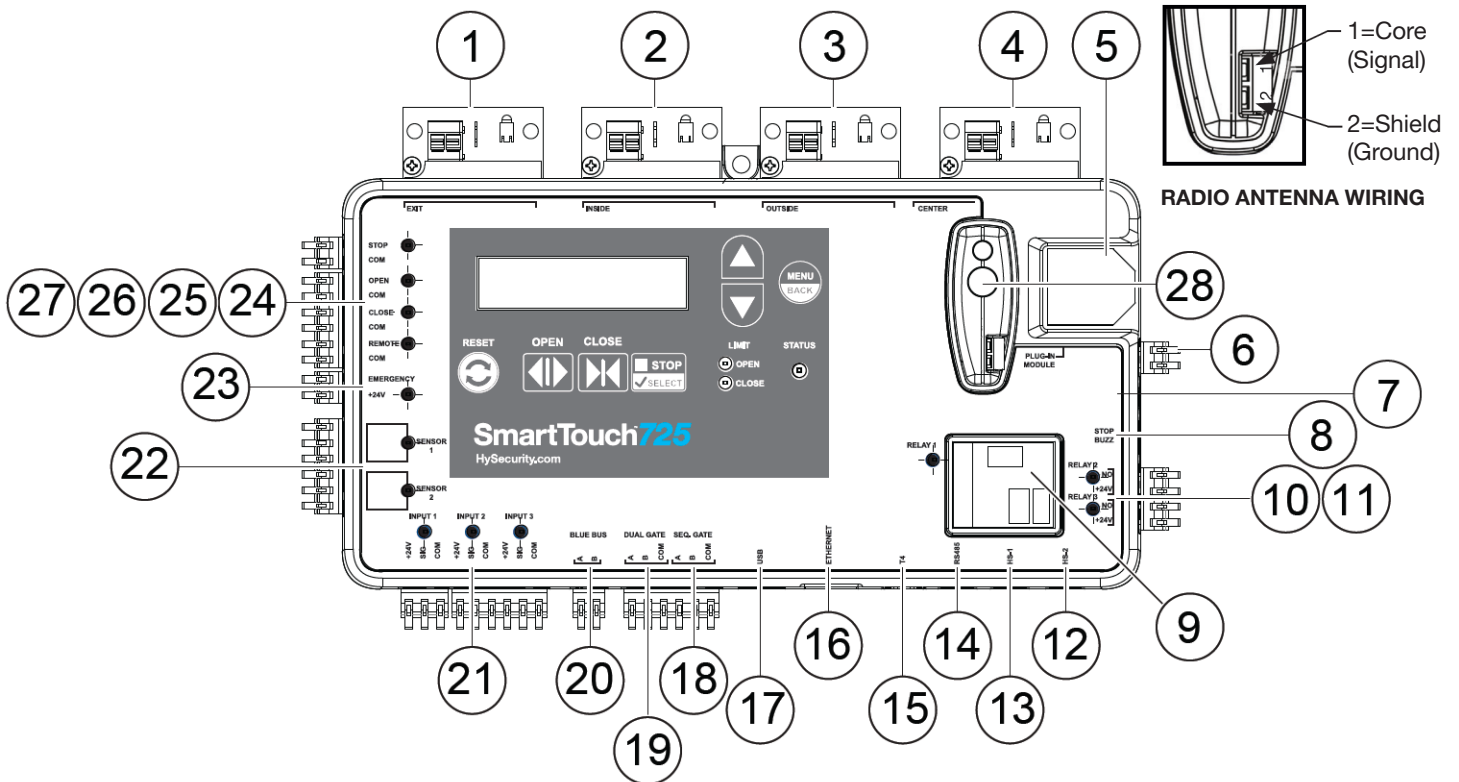

Figure 46. SmartTouch 725 Controller Connections

1. **Hy5B EXIT Loop** – This opens a fully closed gate or reopens a closing gate.
2. **Hy5B INSIDE Loop** – Reversing loop on secure side.
3. **Hy5B OUTSIDE Loop** – Reversing loop on public side.
4. **Hy5B CENTER Loop** – Detect vehicle in swing arc of the gate
5. **(Not Used)**
6. **(Not Used)**
7. **Chassis Ground**
8. **Stop/Buzzer Harness**
9. **Relay 1** – Mechanical relay
10. **Relay 2** – Solid state relay
11. **Relay 3** – Solid state relay
12. **HS-2** – Can connect to expansion module.
13. **HS-1** – Harness connects communication to drive module.
14. **RS485**
15. **T4 Port**
16. **Ethernet**
17. **USB** – Used for software updates & fault log download.
18. **Sequenced Gate Connection**
19. **Dual Gate Connection**
20. **BlueBUS** – For use with NICE BlueBUS devices
21. **Programmable Inputs 1-3**
22. **Programmable Sensor Inputs 1-2** – UL 325 required external entrapment sensors
23. **Emergency** – Programmable to fire department open or emergency close
24. **Remote** – Programmable for three functions, defaults to step function
25. **Close** – Close only input
26. **Open** – Open only input
27. **Stop** – Stop and reset input
28. **OXI MegaCode** – Radio for NICE access control devices

# User Interface

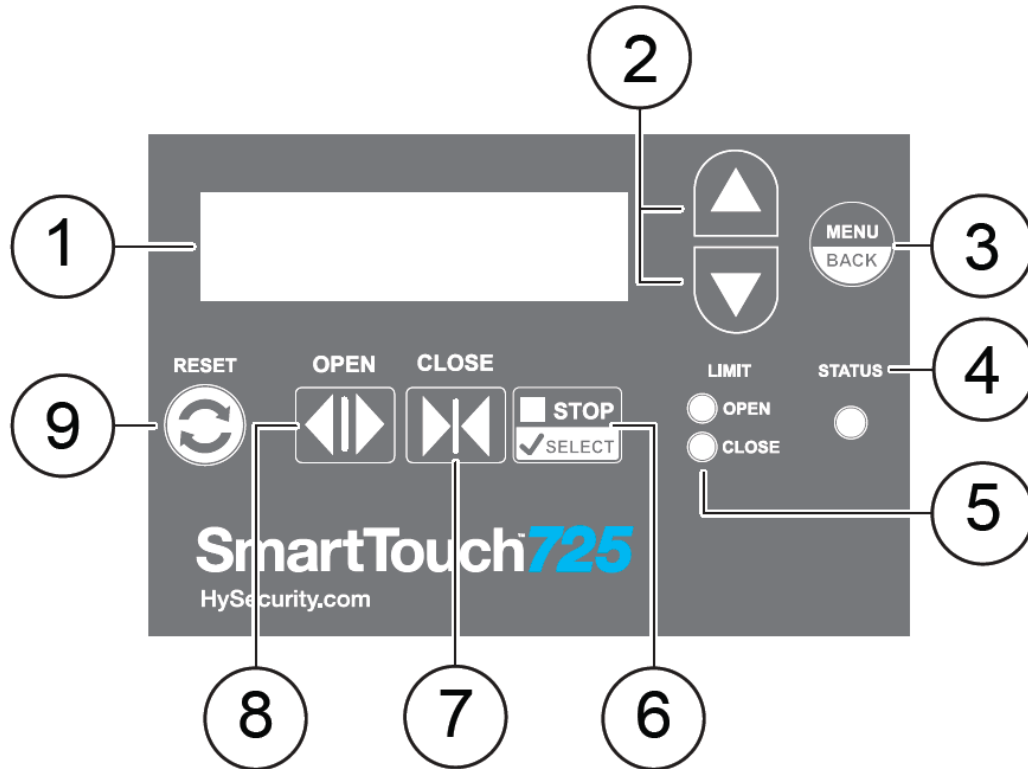

Figure 47. SmartTouch 725 Controller User Interface

1. **OLED Display** – 16 characters per line, 2 line display. Displays current operator status, menus, and alerts/faults/errors. The display will shut off when none of the on board buttons have been pressed for about 10 minutes. Pressing any button will turn it back on. This is to save power and extend the life of the display.
  2. **Up/Down Arrows** – Navigate through menu and display options while in Menu Mode.
  3. **Menu/Back** – Open the configuration menu from the operator status display. Go back from the current menu (exit the current menu).
  4. **Status LED** – Indicates gate operator status
    - a. Flashing Red – An Alert, Fault, or Error has occurred. Immediately shut down the machine and correct the fault.
    - b. Solid Red – Operator is in Menu Mode
    - c. Flashing Green – Operator is in Run Mode
    - d. Flashing Blue – Operator is pairing with a Bluetooth device.
    - e. Alternating Blue and Red/Green – Operator is communicating with a Bluetooth device.
  5. **Limit Open/Close** – Solid green when target magnet activates limit sensor.
  6. **Stop/Select** – Stops gate travel when in run mode. Press to select current menu option or to confirm setting value
  7. **Close** – Closes the gate while in Run Mode.
  8. **Open** – Opens the gate while in Run Mode.
  9. **Reset** – Press to clear faults and return to Run Mode. Cannot be used in Menu Mode.
- Note: You can configure the menus on battery power when an external power source is not yet present.

# Initial Setup

## CONFIGURE THE SETUP MENU (SWING)

The first time the SmartTouch 725 controller powers on, you must set USAGE CLASS, GATE HANDING, and LEARN LIMITS before normal operation.

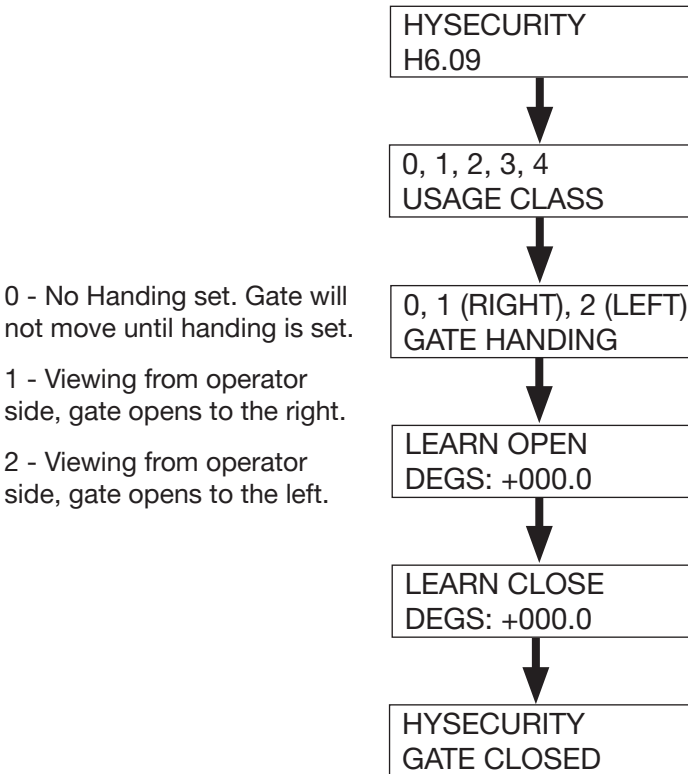

0 - No Handing set. Gate will not move until handing is set.

1 - Viewing from operator side, gate opens to the right.

2 - Viewing from operator side, gate opens to the left.

Figure 48. Configuring Setup Menu

1. Set the AC and DC switches to ON. Firmware version appears on the display and then USAGE CLASS - 0.
2. Press SELECT, press the UP or DOWN arrow to navigate to the correct USAGE CLASS (page 5), and press SELECT to accept the value.
3. Press the UP or DOWN arrow until GATE HANDING appears on the display, press SELECT, press the UP or DOWN arrow to navigate to the correct option, and press SELECT to accept value.
4. The SmartTouch 725 controller resets, display shows "1 (STARTING) - SCAN BLUEBUS" then shows "SCANNING FOR BLUEBUS."
5. After BlueBus Scan, operator display shows "LEARN OPEN - DEGS: 000.0."
6. Press the OPEN button and the gate will slowly move to, and stop on, the open limit.

7. Press the stop/select button twice to store the open limit position. Display will show Learn Close.
8. Press the CLOSE button and the gate will slowly move to, and stop on, the close limit.
9. Press the SELECT button twice to store the close limit position. Operator will reset and display Gate Closed.

## NAVIGATE THE MENUS

Press MENU/BACK to enter the menus or to exit the current screen (up one level without saving any changes).

Press the UP or DOWN arrow to change the current selection until you find the one you want.

Press SELECT to access the menu or sub-menu. Press SELECT to accept the current option or value.

Note: These navigation instructions are the same throughout the SmartTouch 725 controller menus.



# SmartTouch 725 Controller Menus

These are the top level menus in the SmartTouch 725 controller. The following pages show the submenus with settings and descriptions.

OPERATOR CONFIGURATIONS

OPERATOR FUNCTIONS

OPERATOR COMMUNICATIONS

PROGRAMMABLE INPUTS

ENTRAPMENT SENSOR  
RESPONSE

USER RELAY OUTPUTS

LOOP OPTIONS

EXTERNAL COMMUNICATIONS

EXPANSION BOARD INPUTS

DIAGNOSTICS MENU

24/7 CLOCK AND TIMER

# Operator Configurations

- **USAGE CLASS:** UL 325 designations 1-4 (refer to Safety Requirements page 6).
- **CLOSE TIMER:** Number of seconds before open gate initiates closure after all inputs are clear.
- **GATE HANDING:** Direction gate opens when viewed from the operator.
- **AC LOSS:** Action operator performs during an AC power loss. (Refer to Advanced manual.)
- **BATTERY TYPE:** Configure if using larger capacity batteries. (Refer to Advanced Manual.)
- **OPEN TIME ALERT:** Activates relay (function 8) when gate is open longer than selected time period.
- **LOITERING ALERT:** Activates relay (function 13) when vehicle is over Outside Obstruction Loop with gate closed longer than selected time period.
- **LEARN LIMIT:** Set to 1 to place operator in learn limits mode. Installer must then set open and close limits.
- **FACTORY DEFAULTS:** Set to 1 to erase all installer entered settings and return to factory defaults.
- **OPERATOR TYPE:** Factory set. Used only if replacing the SmartTouch 725 Controller.
- **MENU PIN:** Allows installer to set a 4-digit security pin to restrict access to SmartTouch 725 controller menus.

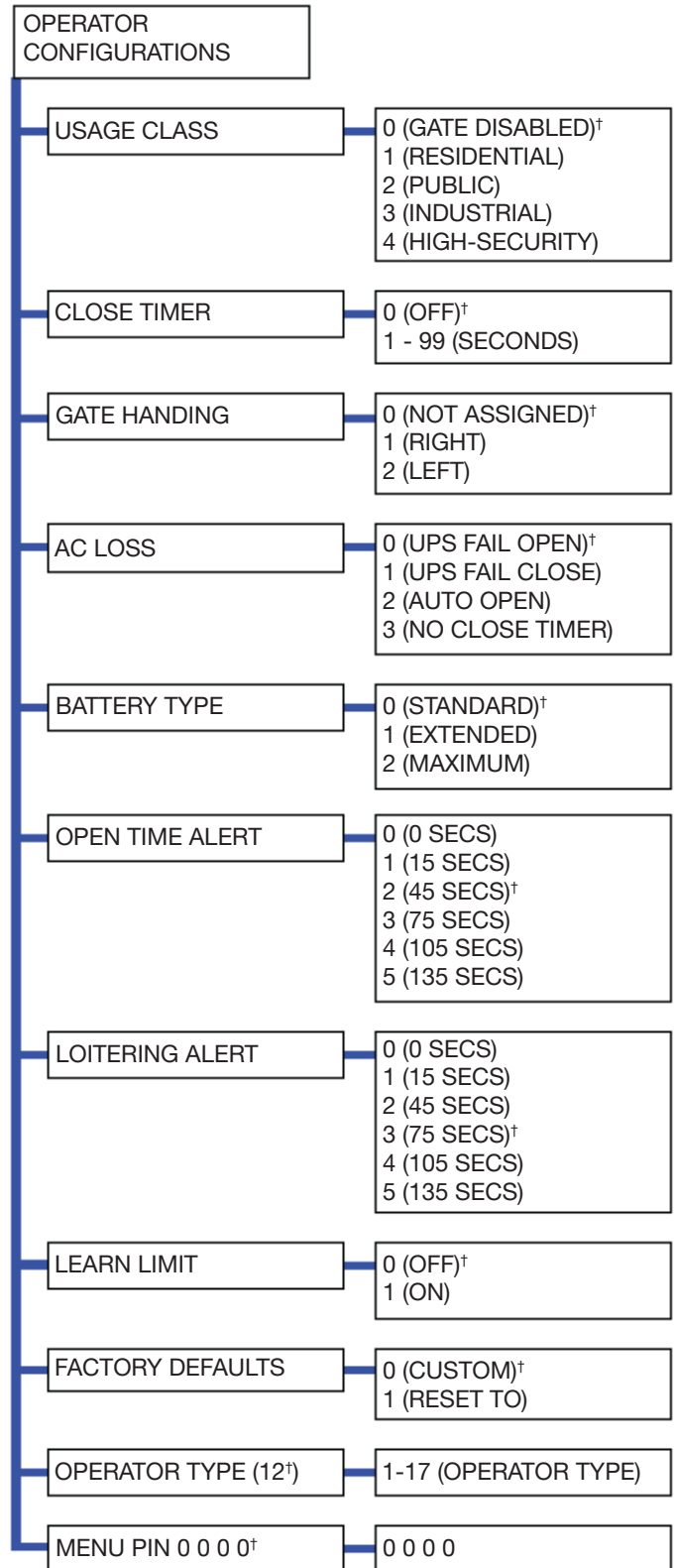

<sup>†</sup> = Indicates default

# Operator Configurations

**Table 10. SwingSmart 535 Operator Configurations Settings**

MENU DISPLAY	SETTINGS	DESCRIPTION
USAGE CLASS	<b>0 = Gate disabled</b> 1 = Residential 1 to 4 units 2 = Comm./public access 3 = Light industrial 4 = Industrial secure	Assign the operator's Usage Class designation per UL 325 standards. The installer must designate a usage class before the operator will function.
CLOSE TIMER	<b>0 = Off</b> 1-99 (seconds)	Number of seconds before open gate initiates closure after all inputs are clear.
GATE HANDING	<b>0 = NOT ASSIGNED</b> 1 = RIGHT 2 = LEFT	Designates which way a gate opens viewed from operator. If it opens to the left, it is a left-hand gate.
AC LOSS	<b>0 = UPS FAIL OPEN</b> 1 = UPS FAIL CLOSE 2 = AUTO OPEN 3 = NO CLOSE TIMER	Action operator performs during an AC power loss.
BATTERY TYPE	<b>0 = STANDARD</b> 1 = EXTENDED 2 = MAXIMUM	Configures operator's battery type. Standard is for 8Ah batteries, Extended is for 35Ah batteries, and Maximum is for 110Ah batteries.
OPEN TIME ALERT	0 = 0 (seconds) 1 = 15 <b>2 = 45</b> 3 = 75 4 = 105 5 = 135	Activates relay (function 8) when gate is open longer than selected time period.
LOITERING ALERT	0 = 0 (seconds) 1 = 15 2 = 45 <b>3 = 75</b> 4 = 105 5 = 135	Activates relay (function 13) when vehicle is over Outside Obstruction Loop with gate closed longer than selected time period.
LEARN LIMIT	<b>0 = OFF</b> 1 = ON	Set to 1 to place operator in learn limits mode. Installer must then set open and close limits.
FACTORY DEFAULTS	<b>0 = CUSTOM</b> 1 = RESET TO	Set to 1 to erase all installer entered settings and return to factory defaults.
OPERATOR TYPE	<b>12 = SWINGSMART 535</b>	Factory set. Used only if replacing the SmartTouch 725 Controller.
MENU PIN	<b>0 0 0 0</b> ^	Allows installer to set a 4-digit security pin to restrict access to SmartTouch 725 controller menus.

# Operator Functions

OPERATOR FUNCTIONS	
OPEN SPEED	1 (SLOWEST) 2 3 4 5 <sup>†</sup> 6 7 8 9 10 (FASTEST)
CLOSE SPEED	1 (SLOWEST) 2 3 4 5 <sup>†</sup> 6 7 8 9 10 (FASTEST)
HOLD TO OPEN	0 (OFF) <sup>†</sup> 1 (ON)
HOLD TO CLOSE	0 (OFF) <sup>†</sup> 1 (ON)
RADIO OPTIONS	0 (STEP FUNCTION) <sup>†</sup> 1 (OPEN ONLY) 2 (OPEN/CLOSE)
WARN BEFORE OPER	0 (OFF) 1 (ON) 2 (ON 2 SEC) <sup>†</sup>
FORCE OPEN ALERT	0 (OFF) <sup>†</sup> 1 (ON)
DRIFT CLOSE ALERT	0 (OFF) <sup>†</sup> 1 (ON)
MAXIMUM RUN TIME	0 (60 SEC) <sup>†</sup> 1 (300 SEC)

<sup>†</sup> = Indicates default

# Operator Functions

**Table 11. SwingSmart 535 Operator Functions Settings**

MENU DISPLAY	SETTINGS	DESCRIPTION
OPEN SPEED	1 (SLOWEST) <b>5</b> 10 (FASTEST)	Designates how quickly gate opens.
CLOSE SPEED	1 (SLOWEST) <b>5</b> 10 (FASTEST)	Designates how quickly gate closes.
HOLD TO OPEN	<b>0 = OFF</b> 1 = ON	Set to 0 to produce a gate open when a momentary signal is transmitted. Set to 1 if a constant hold to open signal, such as a push button control, is being used. You must set HOLD TO OPEN to 1 to comply with UL 325 Type D protection.
HOLD TO CLOSE	<b>0 = OFF</b> 1 = ON	Set to 0 to produce a gate closure when a momentary signal is transmitted. Set to 1 if a constant hold to close signal, such as a push button control, is being used. A setting of 1 also deactivates the automatic close timer and causes its menu to disappear. You must set HOLD TO CLOSE to 1 to comply with UL 325 Type D protection.
RADIO OPTIONS	<b>0 = STEP FUNCTION</b> 1 = OPEN ONLY 2 = OPEN/CLOSE	Default setting is to function as a STEP function where each consecutive activation reverses or stops the gate. First activation opens the gate. Configures radio input for open only (1). If changed to setting 2 then adds capability for radio input to close gate, but only when gate is fully open.
WARN BEFORE OPER	0 = OFF 1 = ON <b>2 = ON 2 SEC</b>	Controls warn-before-operate buzzer and can be configured three ways: Set to 0: Buzzer is disabled Set at 0, buzzer will still beep when alerts, faults, errors, or entrapment are detected. Set to 1: Buzzer beeps for 3 seconds before gate motion begins and continues through entire gate travel. Set to 2: buzzer beeps for 3 seconds before gate motion begins and continues for 2 seconds of gate travel.  <div style="border: 1px solid black; background-color: #f4a460; padding: 5px; margin-top: 10px;"> <p><b>⚠ WARNING</b></p> <p>Do NOT cut wires to buzzer or unplug it as operator will not be in compliance with UL 325. Failure to comply may result in serious injury or death.</p> </div>
FORCE OPEN ALERT	<b>0 (OFF)</b> 1 (ON)	Intended for highly secure facilities. Set to 1, the operator sounds the 3-second “warn before operate” buzzer alarm and initiates a closure if the gate is forced open and the closed limit switch disengages. The motor starts to secure the gate. If the gate does not fully close within 4s, the motor turns off and the buzzer sounds for 30 seconds. The display shows ALERT 1 - FORCED OPEN.
DRIFT CLOSE ALERT	<b>0 (OFF)</b> 1 (ON)	Set to 1, the operator sounds the 3-second “warn before operate” buzzer alarm and initiates an open command if the gate is forced, or drifts, off the open limit switch. The motor starts to reopen the gate. The motor runs for a maximum of 4s and, if the gate is not fully open at the end of this period, the buzzer sounds for 10s. The display shows ALERT 2 - DRIFT CLOSED.
MAXIMUM RUN TIME	<b>0 (60 SEC)</b> 1 (300 SEC)	Assigns a maximum motor run time of 60 or 300 seconds. If the gate opening or closure takes longer than 60 seconds, you’ll need to set the run timer to 1.

# Operator Communications

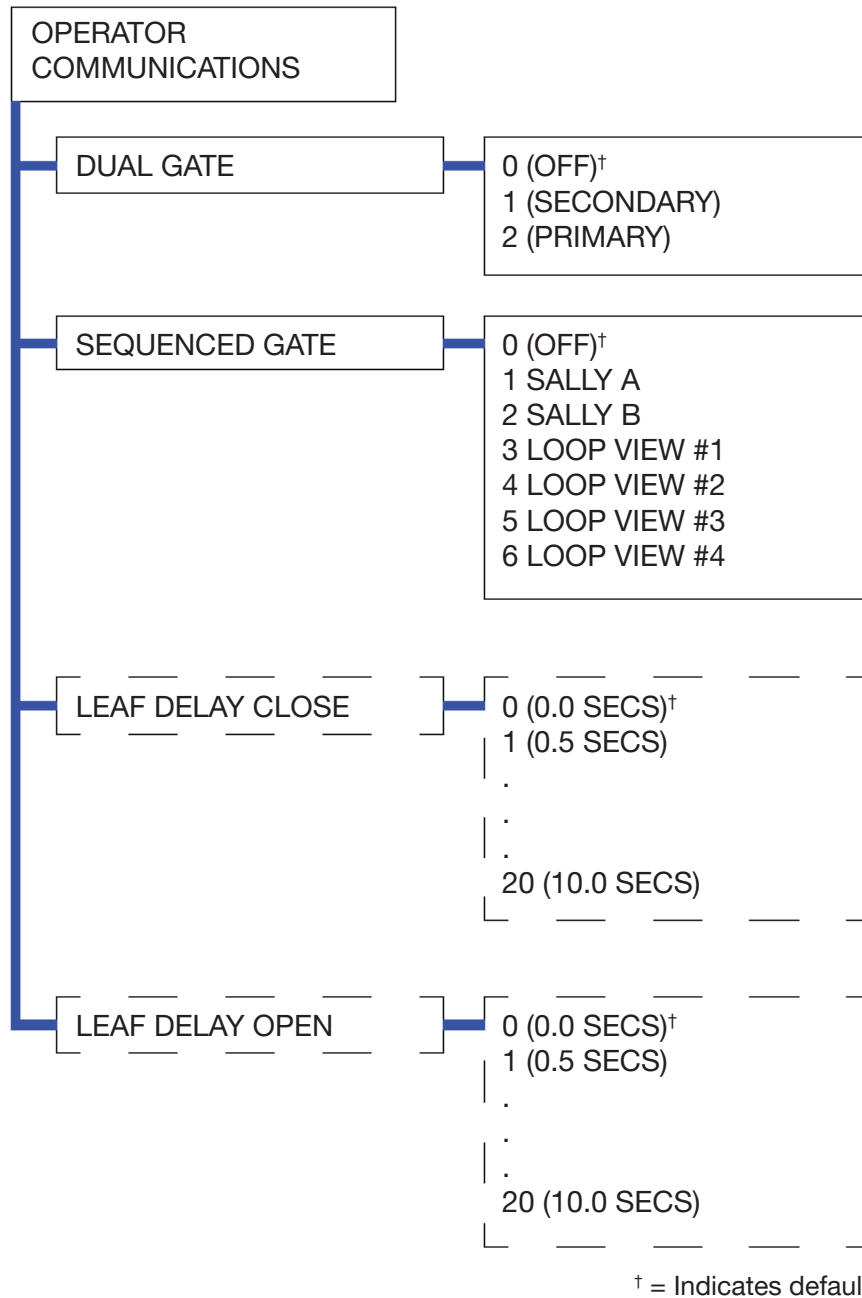

Note: LEAF DELAY OPEN/CLOSE only appear if the gate operator is set up as PRIMARY or SECONDARY.

# Operator Communications

**Table 12. SwingSmart 535 Operator Communications Settings**

MENU DISPLAY	SETTINGS	DESCRIPTION
DUAL GATE	<b>0 = OFF</b> 1 = SECONDARY 2 = PRIMARY	Configures gate operator as a Primary or as a Secondary in a dual-gate installation. When you assign one unit as Primary, you must configure the other as Secondary.
SEQUENCED GATE	<b>0 = OFF</b> 1 = SALLY A 2 = SALLY B 3 = LOOP VIEW #1 4 = LOOP VIEW #2 5 = LOOP VIEW #3 6 = LOOP VIEW #4	<p>This menu is used to configure a Sally Port or Sequenced gate system. For a Sally Port, set one operator to Sally A and the other to Sally B. For sequenced gates, set both operators to the same Loop View setting.</p> <p>Establishes communication after wiring two gate operators as sequenced gates.</p> <p>Note: After selecting SEQUENCED GATE settings, set the CLOSE TIMER in each gate operator.</p>
LEAF DELAY CLOSE	<b>0 = 0.0 (seconds)</b> 1 = 0.5 2 = 1.0 ... 20 = 10	Only appears if the gate operator is set up as PRIMARY or SECONDARY. Available settings are 1 through 20. Each increment adds 0.5 second time delay following a command to close before the operator activates. Provides up to a 10 second time before the gate starts closing.
LEAF DELAY OPEN	<b>0 = 0.0 (seconds)</b> 1 = 0.5 2 = 1.0 ... 20 = 10	Only appears if the gate operator is set up as PRIMARY or SECONDARY. Available settings are 1 through 20. Each increment adds 0.5 second time delay following a command to open before the operator activates. Provides up to a 10 second time delay before the gate starts opening.

# Bi-Parting Gate Setup

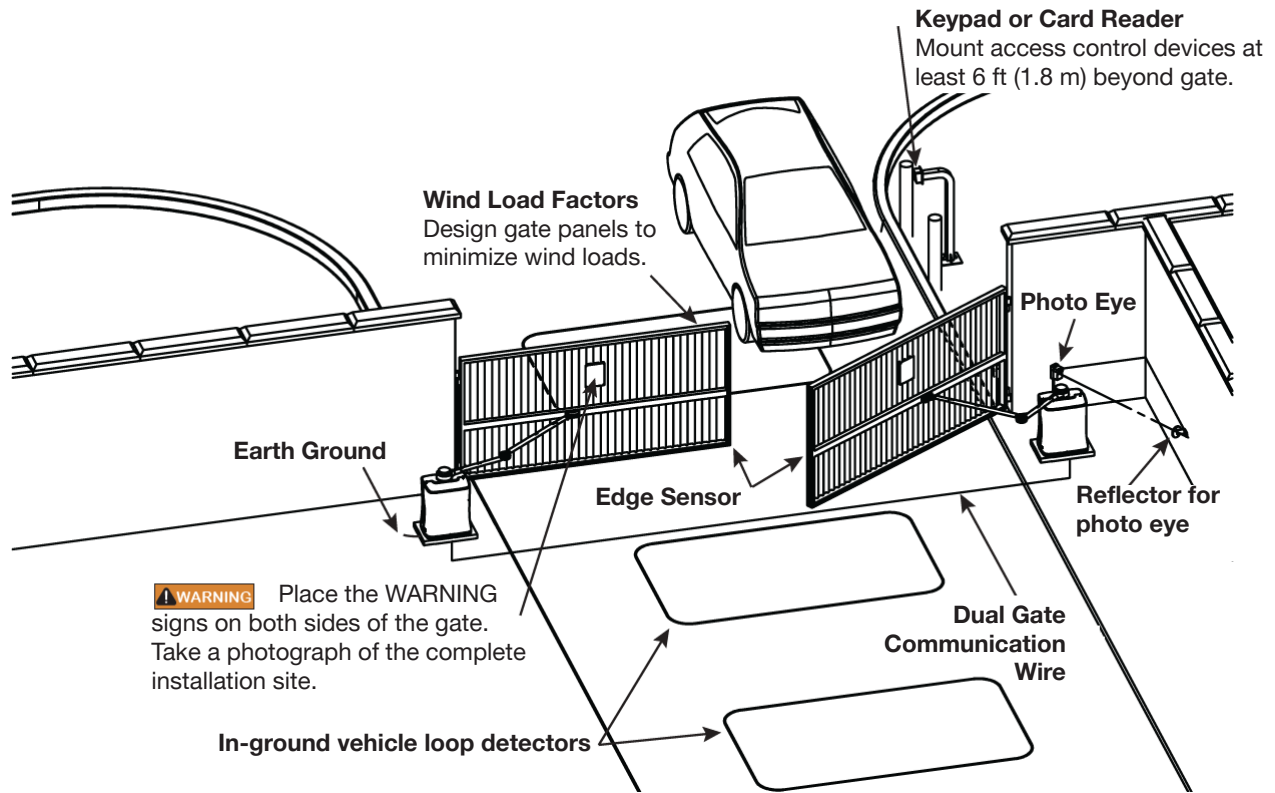

## BI-PARTING GATE SETUP:

1. Install the primary and secondary operators.
2. Set up external entrapment sensors on both operators. Vehicle detectors may be installed in either operator. Make these connections before you connect the operators.
3. Test cycle the operators independently to make sure there are no problems with gate travel and open/close limits.
4. Install a twisted shielded 2 pair wire harness between the two operators. Match A-A, B-B, and COM-COM. Install the grounding shield on only one of the controller mounting brackets.

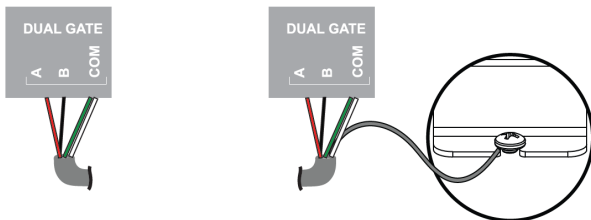

Figure 49. Dual Gate Connection

5. Set one operator as the primary and the other as the secondary.
6. Test the gate operation.
7. Adjust LEAF DELAY CLOSE and LEAF DELAY OPEN if required.

## SEQUENCED GATE WIRING:

Sequenced gate wiring is similar to dual gate wiring. Instead of the DUAL GATE terminal, use the SEQ GATE terminal. Install a twisted shielded 2 pair wire harness between the two operators. Match A-A, B-B, and COM-COM. Install the grounding shield on only one of the controller mounting brackets. Figure 50. Refer to page 48 for loop view diagrams.

When sequenced gates are being used in barrier arm and security gate systems, both operators must be set to the same loop view setting. When sequenced gates are used for a Sally Port system, then one gate must be set to Sally A and the other must be set to Sally B.

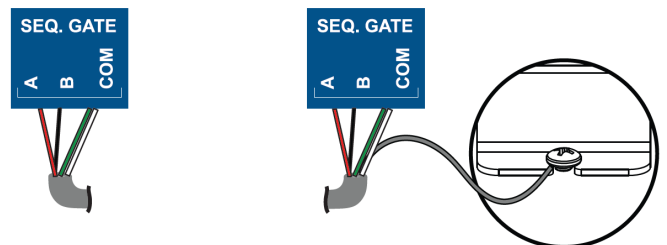
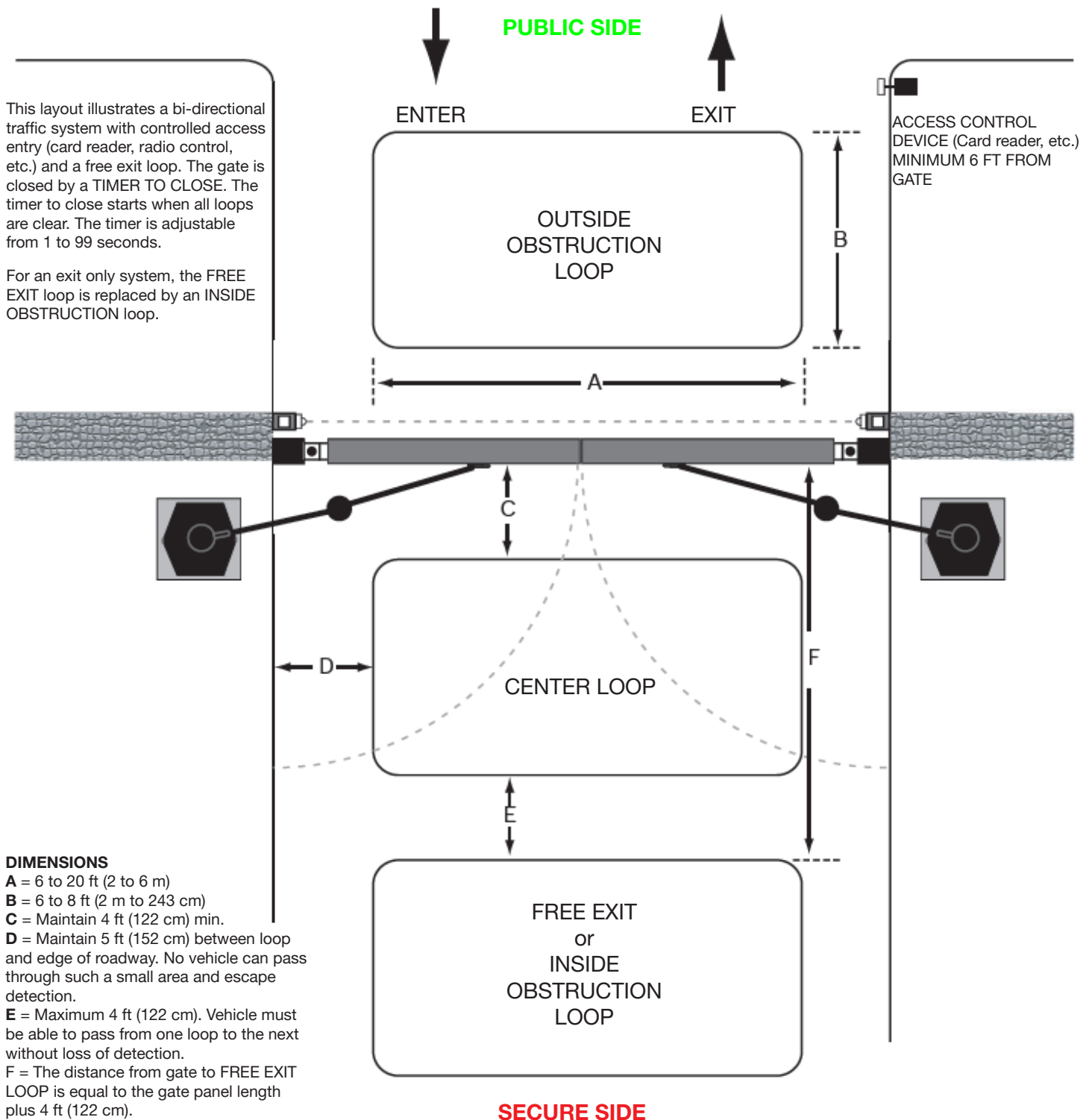

Figure 50. Sequenced Gate Connection

# Vehicle Detector Loop Layouts



## Vehicle Detectors and Loop Layout for Dual Gate Openings less than 28 feet\* or Single Gate Openings less than 20 feet\*

\* Note: A minimum of three (3) detectors are required for this type of gate.

# Vehicle Detector Loop Layouts

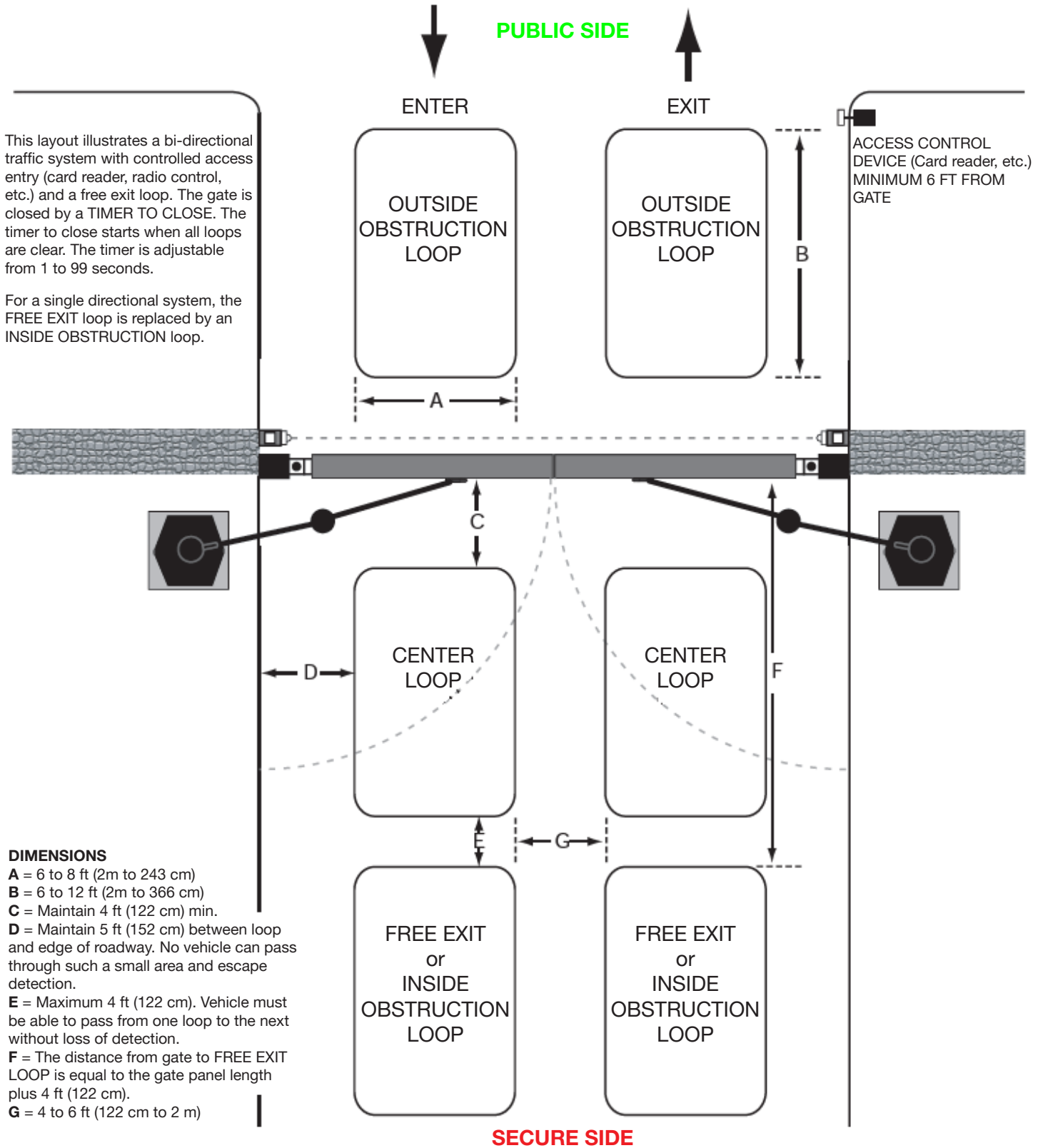

## Vehicle Detectors and Loop Layout for Gate Openings greater than 28 feet\*

\* Note: A minimum of three (3) detectors are required for this type of gate.

# Sequenced Gate: Loop View #1



To sequence the gates, set the menu item, SEQUENCED GATE to "3" in both gate operators.\*

### Operator & Loops\*\*

As traffic control and security gates are separated farther apart, Reset Loop moves toward center.

### \*\*NOTICE

For sequenced gates to operate properly, all vehicle detectors must be wired to the Traffic Control Gate.

If a communication failure occurs, an AL22 (Alert 22) appears and the buzzer sounds. The Traffic Control Gate maintains functionality while the Security Gate defaults to open until communication is restored (or the Security Gate is manually closed).

### \*\*NOTICE

Center to center between gates:  
4 ft minimum (122 cm)  
9 ft maximum (274 cm)

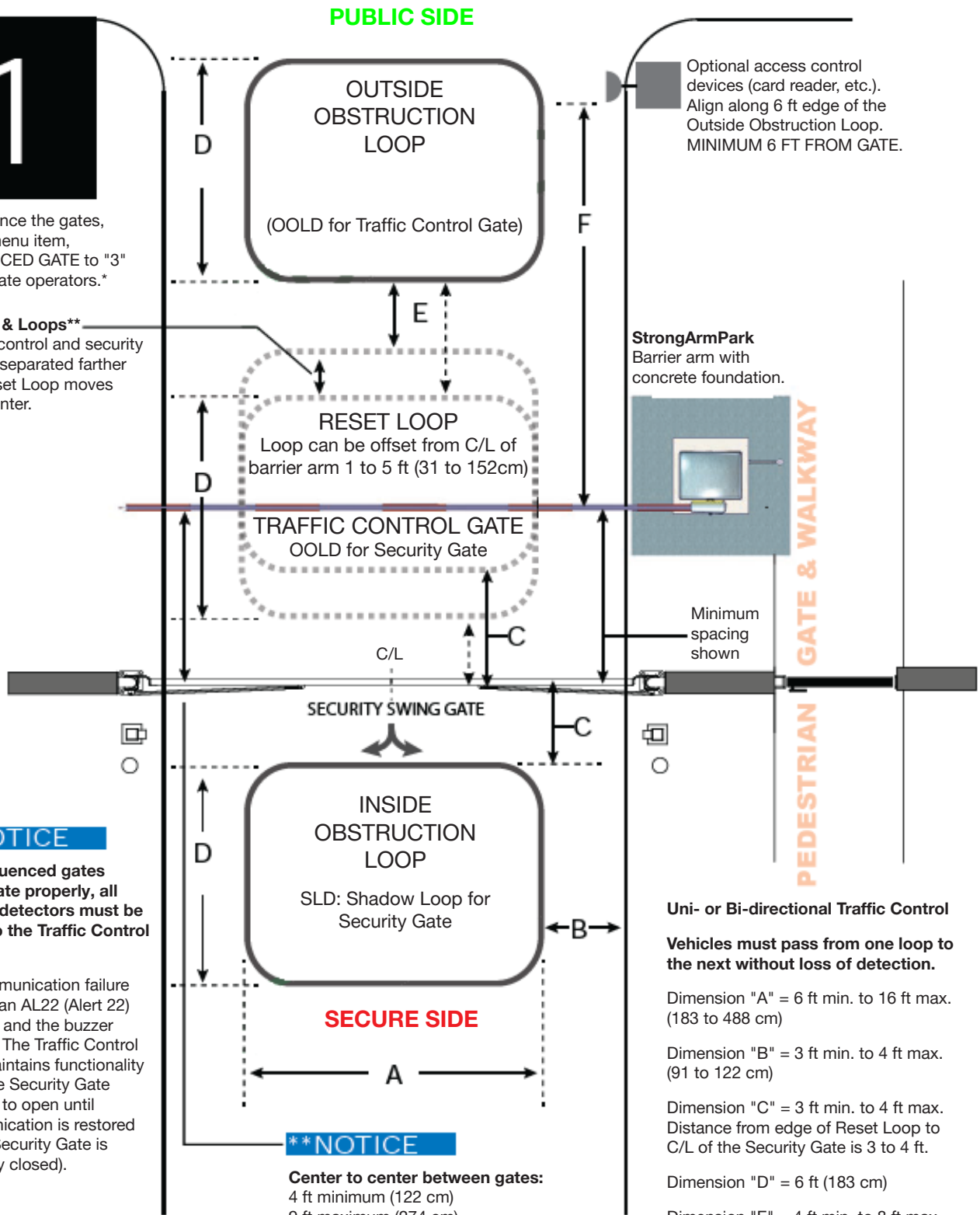

Optional access control devices (card reader, etc.). Align along 6 ft edge of the Outside Obstruction Loop. MINIMUM 6 FT FROM GATE.

**StrongArmPark**  
Barrier arm with concrete foundation.

Minimum spacing shown

### Uni- or Bi-directional Traffic Control

Vehicles must pass from one loop to the next without loss of detection.

Dimension "A" = 6 ft min. to 16 ft max. (183 to 488 cm)

Dimension "B" = 3 ft min. to 4 ft max. (91 to 122 cm)

Dimension "C" = 3 ft min. to 4 ft max. Distance from edge of Reset Loop to C/L of the Security Gate is 3 to 4 ft.

Dimension "D" = 6 ft (183 cm)

Dimension "E" = 4 ft min. to 8 ft max. (122 to 244 cm). Reset Loop can be offset from C/L of gate 1 to 5 ft (31 to 152 cm).

Dimension "F" = 10 to 15 ft (3 to 4.6 m)

**DRAWINGS NOT TO SCALE**

# Sequenced Gate: Loop View #2

# 2

To sequence the gates, set the menu item, SEQUENCED GATE to "4" in both gate operators\*.

**Operator & Loops\*\***  
As traffic control and security gates are separated farther apart, Reset Loop moves toward center.

## \*\*NOTICE

For sequenced gates to operate properly, all vehicle detectors must be wired to the Traffic Control Gate.

If a communication failure occurs, an AL22 (Alert 22) appears and the buzzer sounds. The Traffic Control Gate maintains functionality while the Security Gate defaults to open until communication is restored (or the Security Gate is manually closed).

## \*\*NOTICE

Center to center between gates:  
4 ft minimum (122 cm)  
9 ft maximum (274 cm)

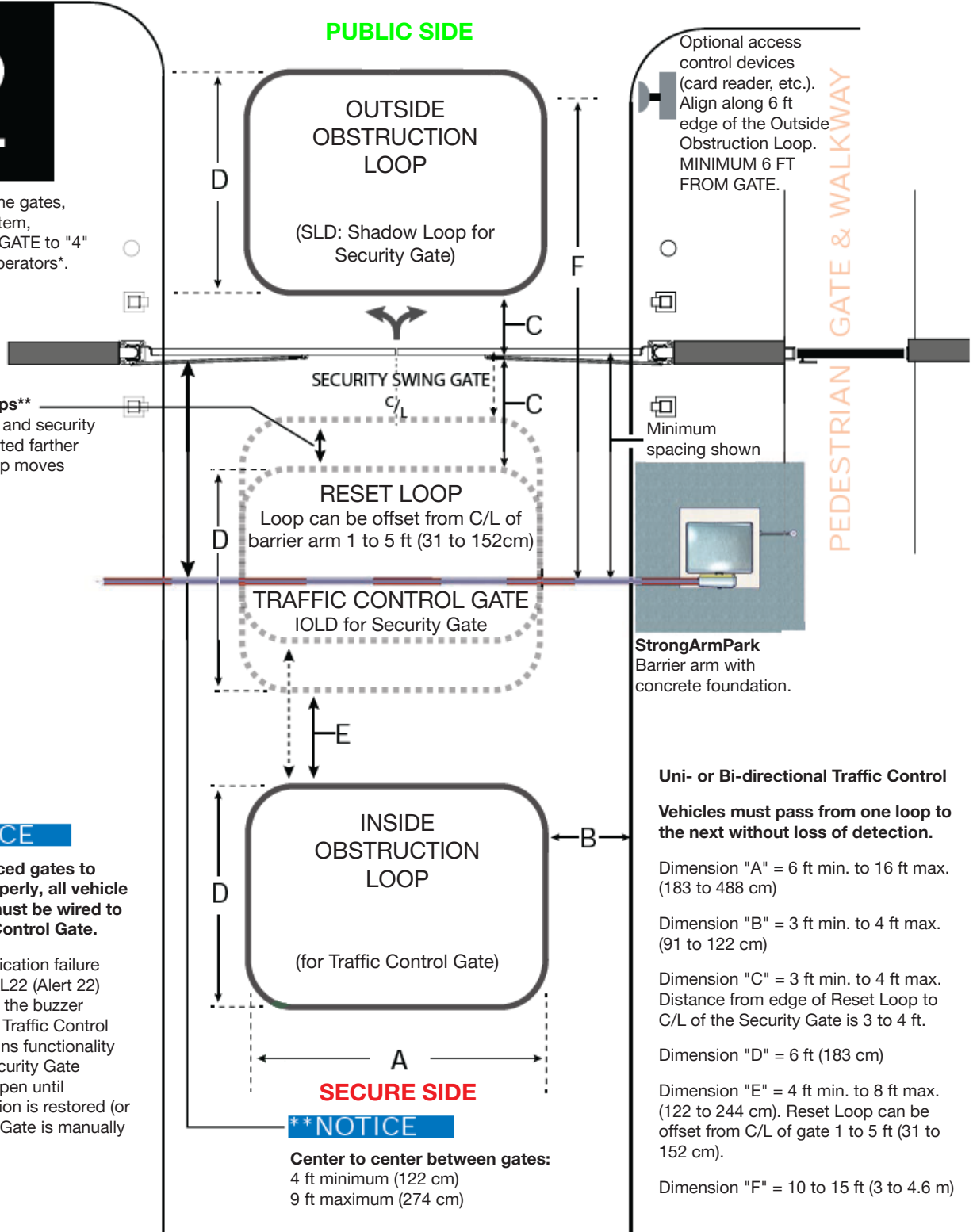

### Uni- or Bi-directional Traffic Control

Vehicles must pass from one loop to the next without loss of detection.

Dimension "A" = 6 ft min. to 16 ft max. (183 to 488 cm)

Dimension "B" = 3 ft min. to 4 ft max. (91 to 122 cm)

Dimension "C" = 3 ft min. to 4 ft max. Distance from edge of Reset Loop to C/L of the Security Gate is 3 to 4 ft.

Dimension "D" = 6 ft (183 cm)

Dimension "E" = 4 ft min. to 8 ft max. (122 to 244 cm). Reset Loop can be offset from C/L of gate 1 to 5 ft (31 to 152 cm).

Dimension "F" = 10 to 15 ft (3 to 4.6 m)

**DRAWINGS NOT TO SCALE**

# Programmable Inputs

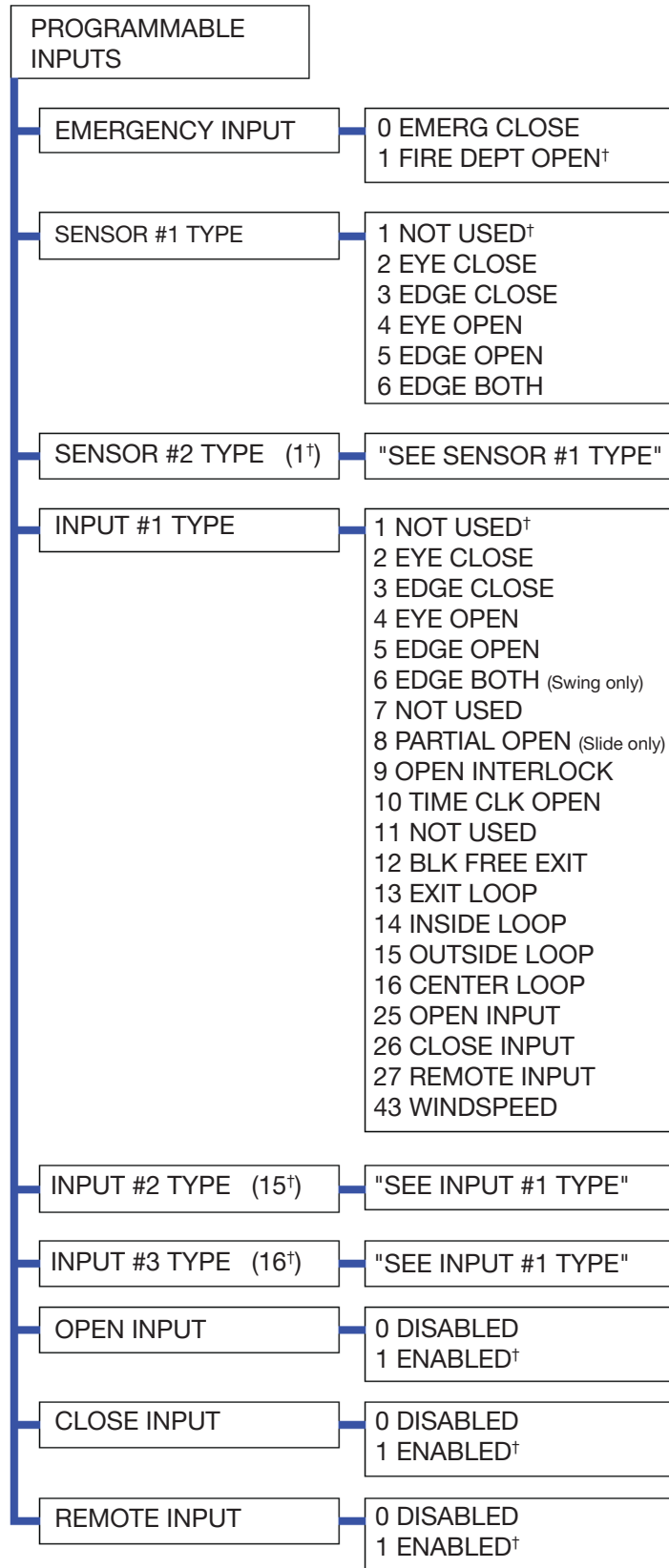

† = Indicates default

# Programmable Inputs

**Table 13. SwingSmart 535 Programmable Inputs Settings**

MENU DISPLAY	SETTINGS	DESCRIPTION
EMERGENCY INPUT	0 = EMERG CLOSE <b>1 = FIRE DEPT OPEN</b>	Activation of this input requires a +24VDC signal. Defaults to Fire Department Open input. When set to 1, signal received through this input overrides all photoelectric eyes and edge sensors and opens gate. Pressing RESET button (or the OPEN or the STOP button) is required before gate can be closed. When set to 0, the input can be used as an Emergency Close.
SENSOR #1 TYPE	<b>1 = NOT USED</b> 2 = EYE CLOSE 3 = EDGE CLOSE 4 = EYE OPEN 5 = EDGE OPEN 6 = EDGE BOTH	Monitored input per UL325 requirements for connection of external entrapment sensors - contact (edge sensor) or non-contact (photo eye). Edge Both is only available in Swing Gate operator types.
SENSOR #2 TYPE	SAME SETTINGS AS SENSOR #1 TYPE <b>1 = NOT USED</b>	Same as Sensor #1 Type
INPUT #1 TYPE	1 = NOT USED 2 = EYE CLOSE 3 = EDGE CLOSE 4 = EYE OPEN 5 = EDGE OPEN 6 = EDGE BOTH (SWING ONLY) 7 = NOT USED 8 = PARTIAL OPEN (SLIDE ONLY) 9 = OPEN INTERLOCK 10 = TIME CLK OPEN 11 = NOT USED 12 = BLK FREE EXIT <b>13 = EXIT LOOP</b> 14 = INSIDE LOOP 15 = OUTSIDE LOOP 16 = CENTER LOOP 25 = OPEN INPUT 26 = CLOSE INPUT 27 = REMOTE INPUT 43 = WINDSPEED	When set to 2-6, this input will be monitored and requires connection of an external sensor's 10K or 4-wired pulsed output. The common terminal for a monitored sensor must be connected to the switched common at the Sensor 1 or Sensor 2 input. When set to 8-27, this input will be activated and perform the programmed function when the signal input is connected to the common terminal (through a switch, relay, etc.).
INPUT #2 TYPE	SAME SETTINGS AS INPUT #1 TYPE TYPE <b>15 = OUTSIDE LOOP</b>	When set to 8-27, this input will be activated and perform the programmed function when the signal input is connected to the common terminal (through a switch, relay, etc.).
INPUT #3 TYPE	SAME SETTINGS AS INPUT #1 TYPE TYPE <b>16 = CENTER LOOP</b>	When set to 8-27, this input will be activated and perform the programmed function when the signal input is connected to the common terminal (through a switch, relay, etc.).
OPEN INPUT	0 = DISABLED <b>1 = ENABLED</b>	Setting 1 enables the Open input on the left side of the board. Setting 0 disables the Open input.
CLOSE INPUT	0 = DISABLED <b>1 = ENABLED</b>	Setting 1 enables the Close input on the left side of the board. Setting 0 disables the Close input.
REMOTE INPUT	0 = DISABLED <b>1 = ENABLED</b>	Setting 1 enables the Remote Open input on the left side of the board. Setting 0 disables the Remote Open input.

# Controller Inputs

SmartTouch 725 Controller Input (Examples Only)

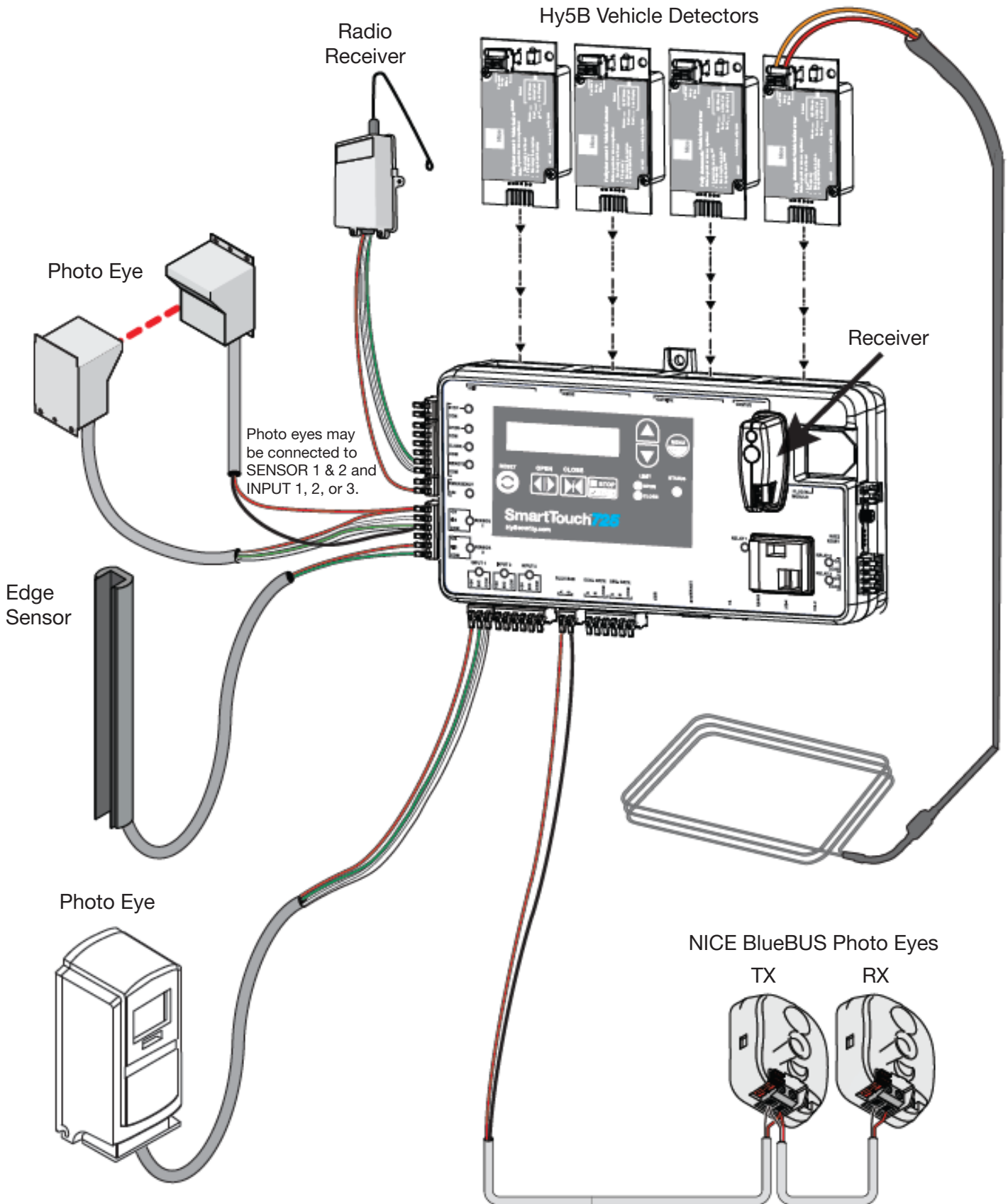

# Entrapment Sensor Wiring - BlueBUS

Nice HySecurity provides one BlueBUS through-beam photo eye pair typically used as EYE CLOSE.

## Install a BlueBUS photo eye:

1. Verify the jumpers on transmitter (TX) and receiver (RX) are in the same positions (Figure 51).
2. Install the BlueBUS photo eyes in appropriate locations for entrapment protection (page 12).
3. Set the AC and DC switches to OFF.
4. Route the wires to the inside of the 535 chassis (Figure 7).
5. Install the wires between the TX and RX and then into BlueBUS terminals on the SmartTouch 725 Controller (Figure 51).

Note: With BlueBUS technology there are 4 total close direction pairs and 2 open direction pairs available. Pairs may either be connected in parallel to one another or directly to the SmartTouch 725 Controller.

6. Set AC and DC switches to ON.
7. In EXTERNAL COMMUNICATIONS, select BLUEBUS OPTIONS MENU, and set SCAN FOR DEVICES to 1 (ON).

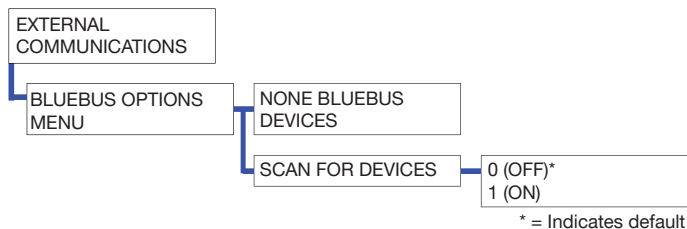

8. Display will show EYE CLOSE BlueBUS P1 or the P# for the jumper configuration used.
9. In ENTRAPMENT SENSOR RESPONSE menu, set the desired response action for each entrapment type.
10. Test the function of each sensor pair.

BlueBUS RX LED Status Light	Status
Off	No power
3 flashes, pause, repeat	Controller has not memorized the pair
Slow flashes	Good signal

Direction	Pair	Jumper Positions (Pairs must match)
CLOSE	P1	
CLOSE	P2	
CLOSE	P3	
CLOSE	P4	
OPEN	P5	
OPEN	P6	

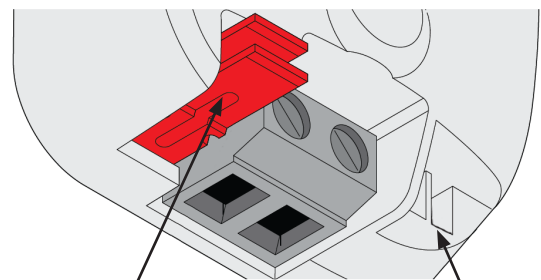

Example jumper position  
CLOSE P1

Jumper storage

Figure 51. BlueBUS and Jumper Designation

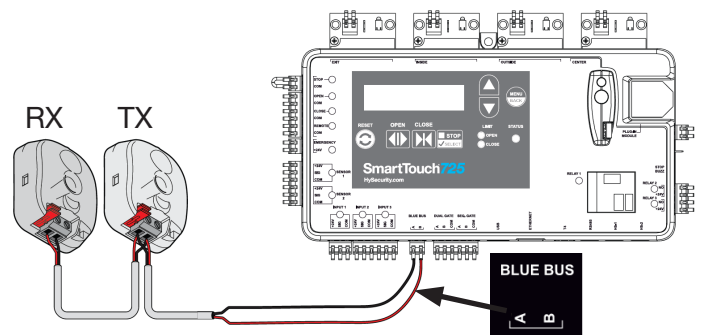

Note: Matching wire polarity is not required for BlueBUS photocells.

Note: Jumper locations shown here are for a CLOSE P1 installation.

Figure 52. Connect the BlueBUS Photo Eye

# Entrapment Sensor Wiring

Additional non-BlueBUS non-contact sensors and contact sensors can connect to the SmartTouch 725 Controller.

1. Install the edge sensor in an appropriate location for entrapment protection (page 12).
2. Set AC and DC switches OFF.
3. Route the wires to the inside of the operator chassis (Figure 7).
4. Install the wires into Sensor #1 or Sensor #2 on the SmartTouch 725 Controller (Figure 53).

5. Set AC and DC switches to ON.
6. In PROGRAMMABLE INPUTS menu, select the SENSOR TYPE for each external entrapment sensor. The indicator LED changes to green when sensor is activated or not installed correctly.
7. In ENTRAPMENT SENSOR RESPONSE menu, set the desired response action for each entrapment type.
8. Test the function of each sensor.

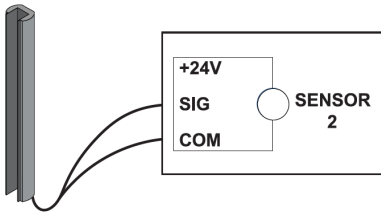
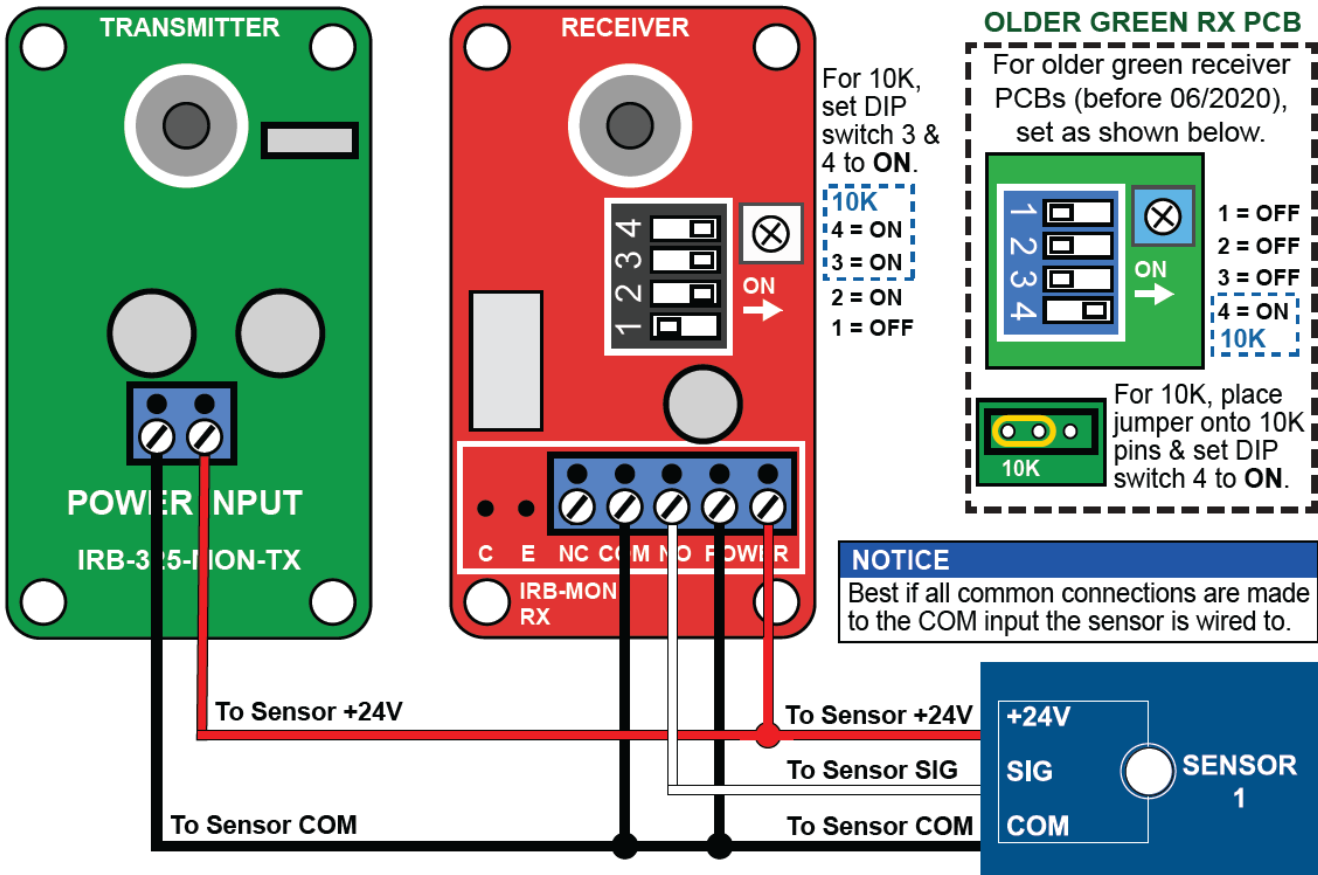

Figure 53. Sensor Connection



EXAMPLE: EMX IRB-MON2 Photo Eye Wiring (10k monitoring)

# Approved Sensor Wiring

All wiring examples show wiring to SENSOR 1, but one can also make these connections to SENSOR 2 as well as INPUT 1-2. Remember to change the setting for the SENSOR or INPUT terminal to match the connected device. Reference the manufacturer's installation instructions for help with programming or other setup issues.

## NOTICE

The SmartTouch 725 Controller inputs use 10K or 4-wire pulsed monitoring. Connect sensor using sensor instructions for the compatible output connections. The SmartTouch 725 Controller does not support normally closed inputs.

Note: For a reference of sensors tested with Nice | HySecurity Operators, see "Table 1. Recommended External Entrapment Protection Sensors List" on page 11.

### Omron E3K-R10K4-NR-1 (Photo Eye)

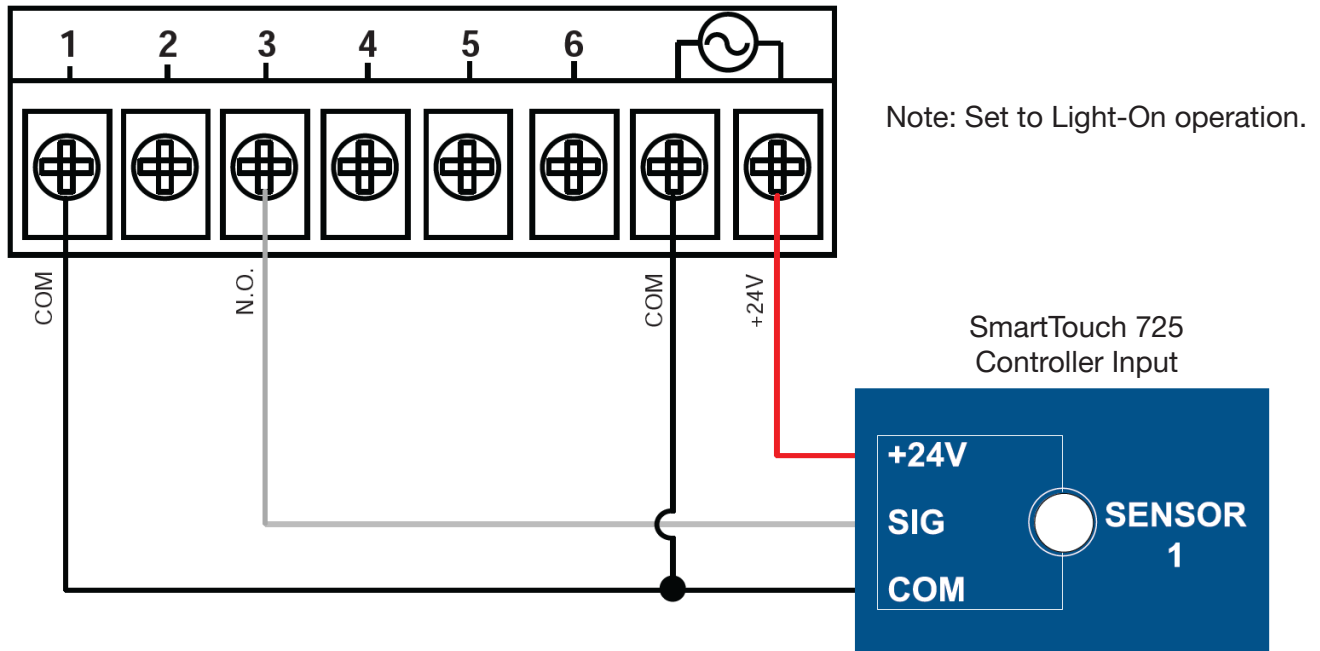

Figure 54. Omron E3K

### EMX NIR-50-325 (Photo Eye)

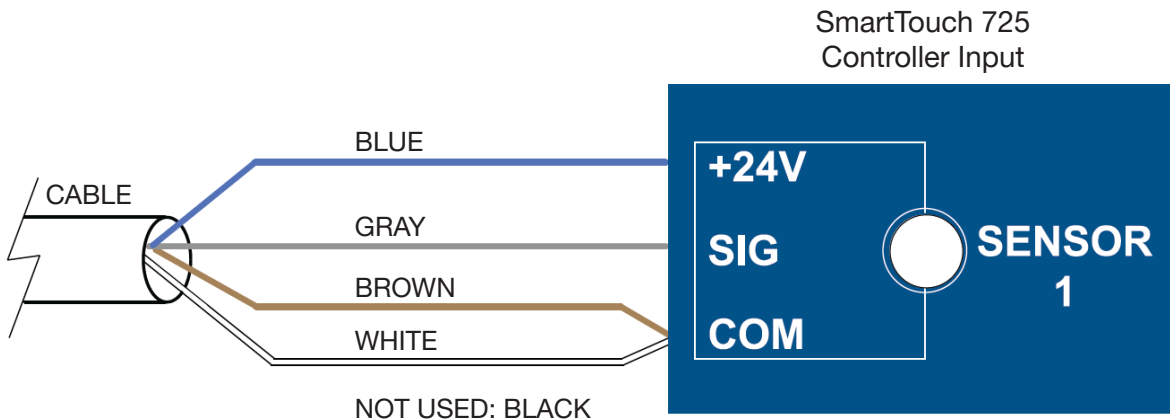

Figure 55. EMX NIR-50-325

# Approved Sensor Wiring

## EMX IRB-RET2 (Photo Eye)

Note: Set board as shown in red boxes per the figure below. Jumpers are three pin type, and placed LEFT or RIGHT as indicated.

### DIAGRAM A: 10K OHM RESISTIVE WIRING

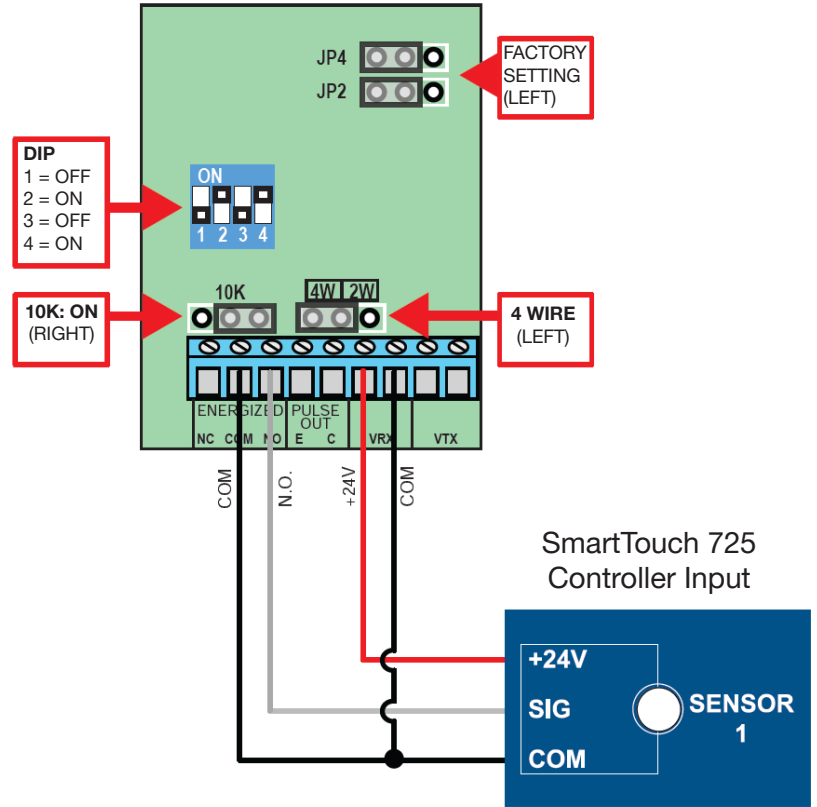

### DIAGRAM B: 4-WIRE PULSED WIRING

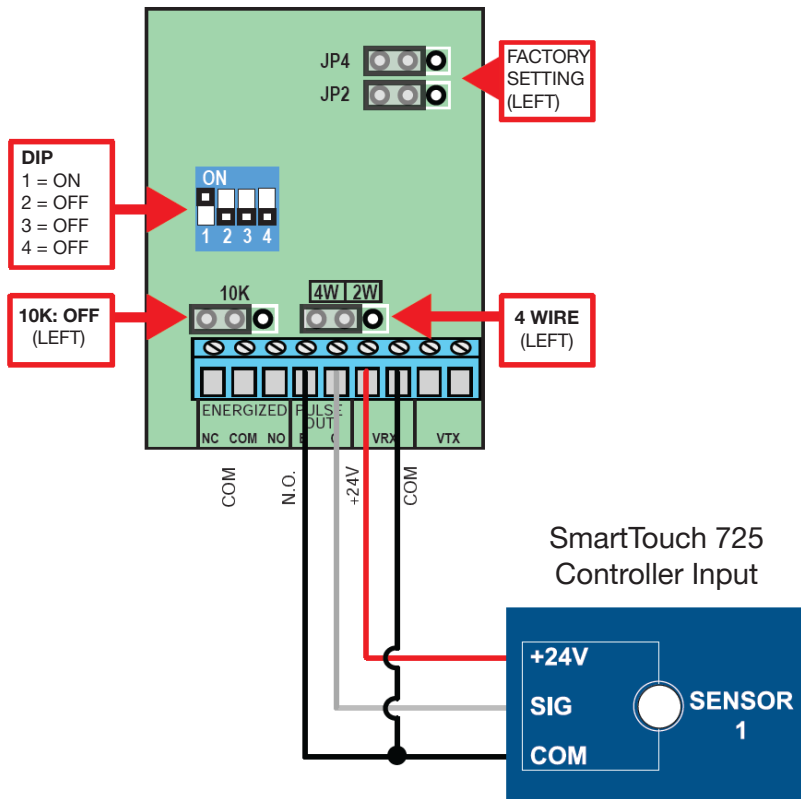

Figure 56. EMX IRB-RET2 Wiring - 10K OHM Resistive (Top) and 4-Wire Pulsed (Bottom)

# Approved Sensor Wiring

## Seco-Larm Enforcer Retro-Reflective (E-931-S50RRGQ) (Photo Eye)

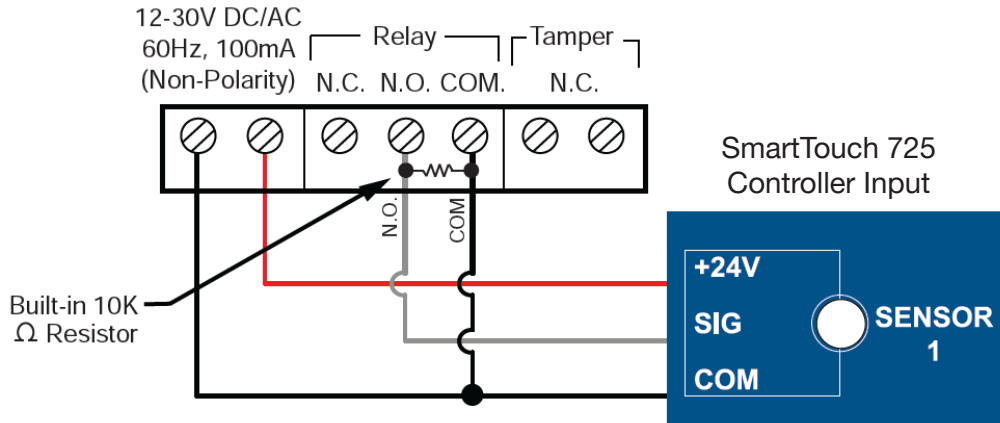

Figure 57. Seco-Larm Enforcer Retro-Reflective (E-931-S50RRGQ)

## Seco-Larm Enforcer Through-Beam (E-960-D90GQ)

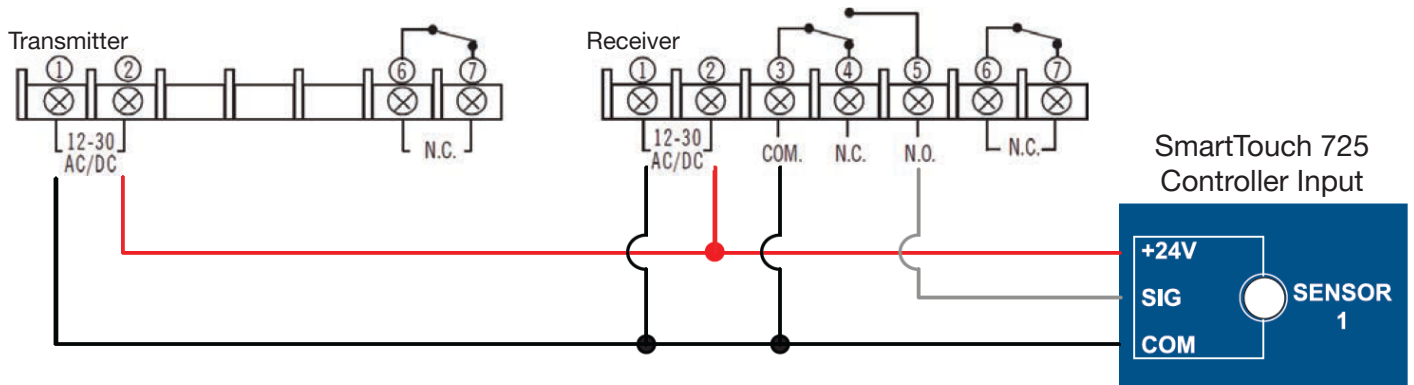

Figure 58. Seco-Larm Enforcer Through-Beam (E-960-D90GQ)

## Transmitter Solutions iGaze RE Kit (Photo Eye)

Note: Dashed lines indicate the secondary wiring connections if an additional 535 sensor input is wired to the sensor. See manufacturer's instructions for details.

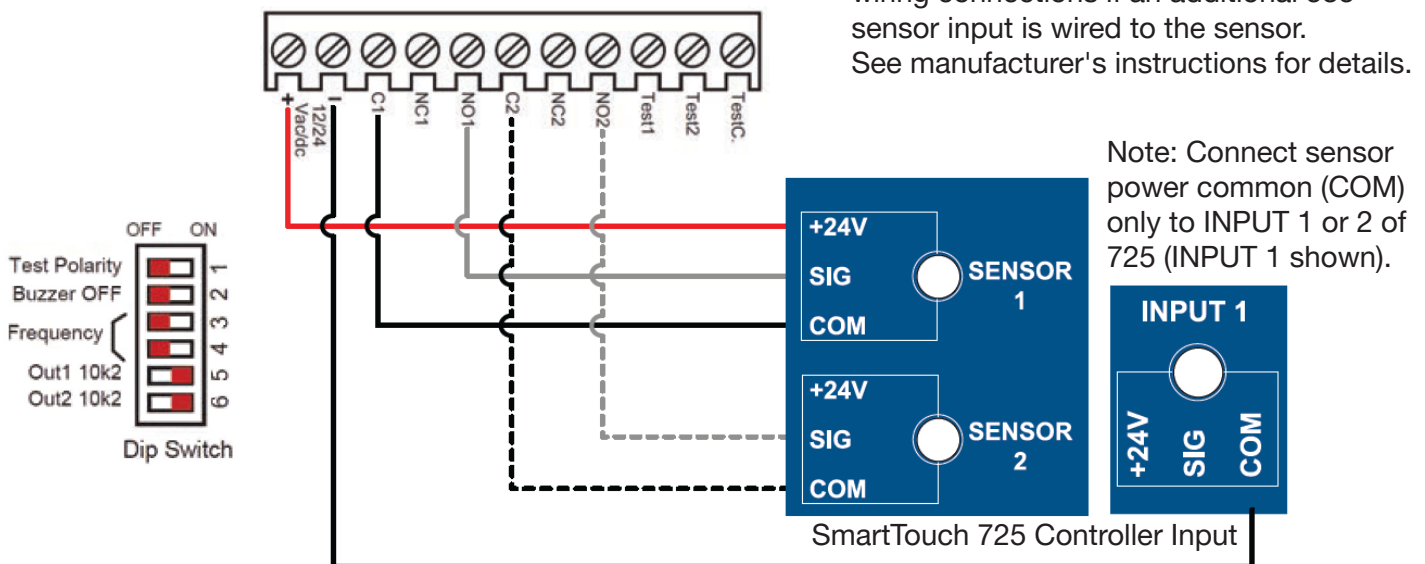

Figure 59. Transmitter Solutions iGaze RE Kit

# Approved Sensor Wiring

## EMX WEL200 (Edge Sensor)

Note: Set board as shown in red boxes per figure below for desired configuration. Jumpers are three pin type, and placed UPPER or LOWER as indicated. Dashed lines indicate the secondary wiring connections if an additional 535 sensor input is wired to the sensor. See manufacturer's instructions for details.

### DIAGRAM A: 10K OHM RESISTIVE WIRING

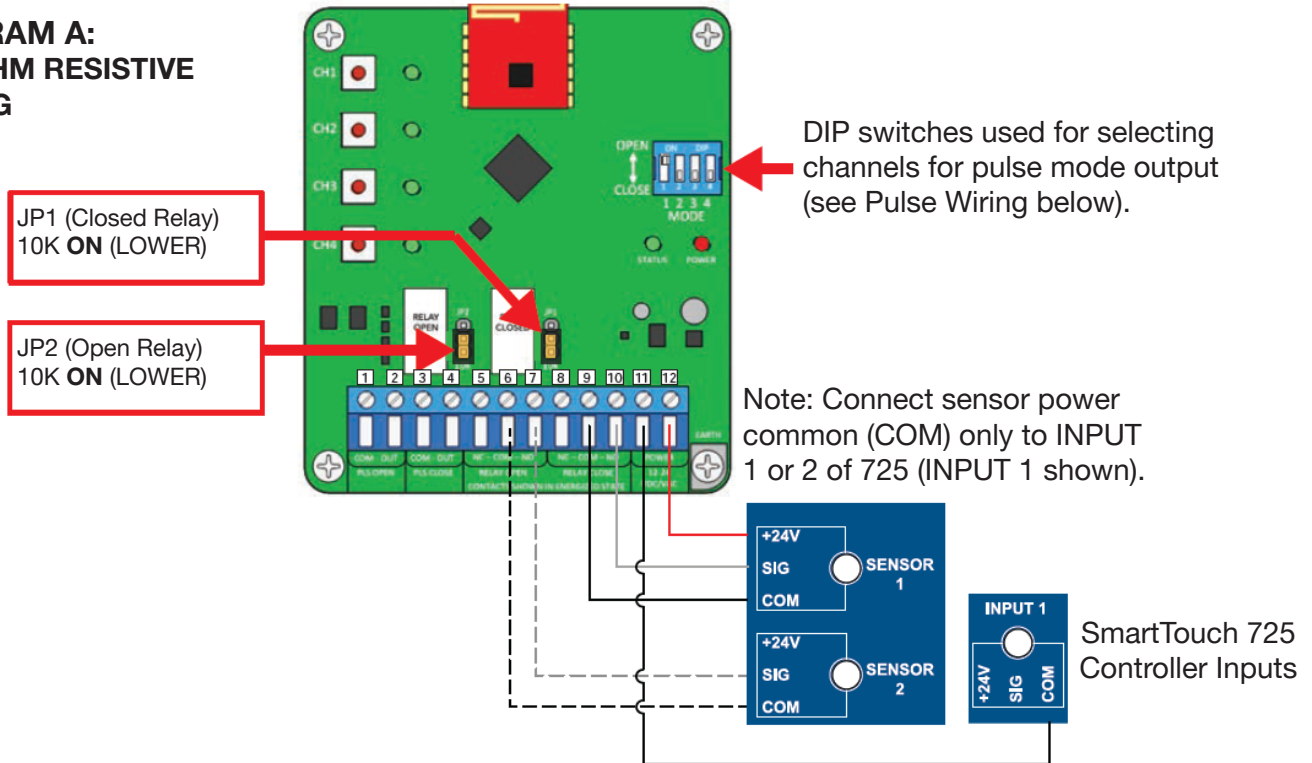

### DIAGRAM B: PULSED WIRING

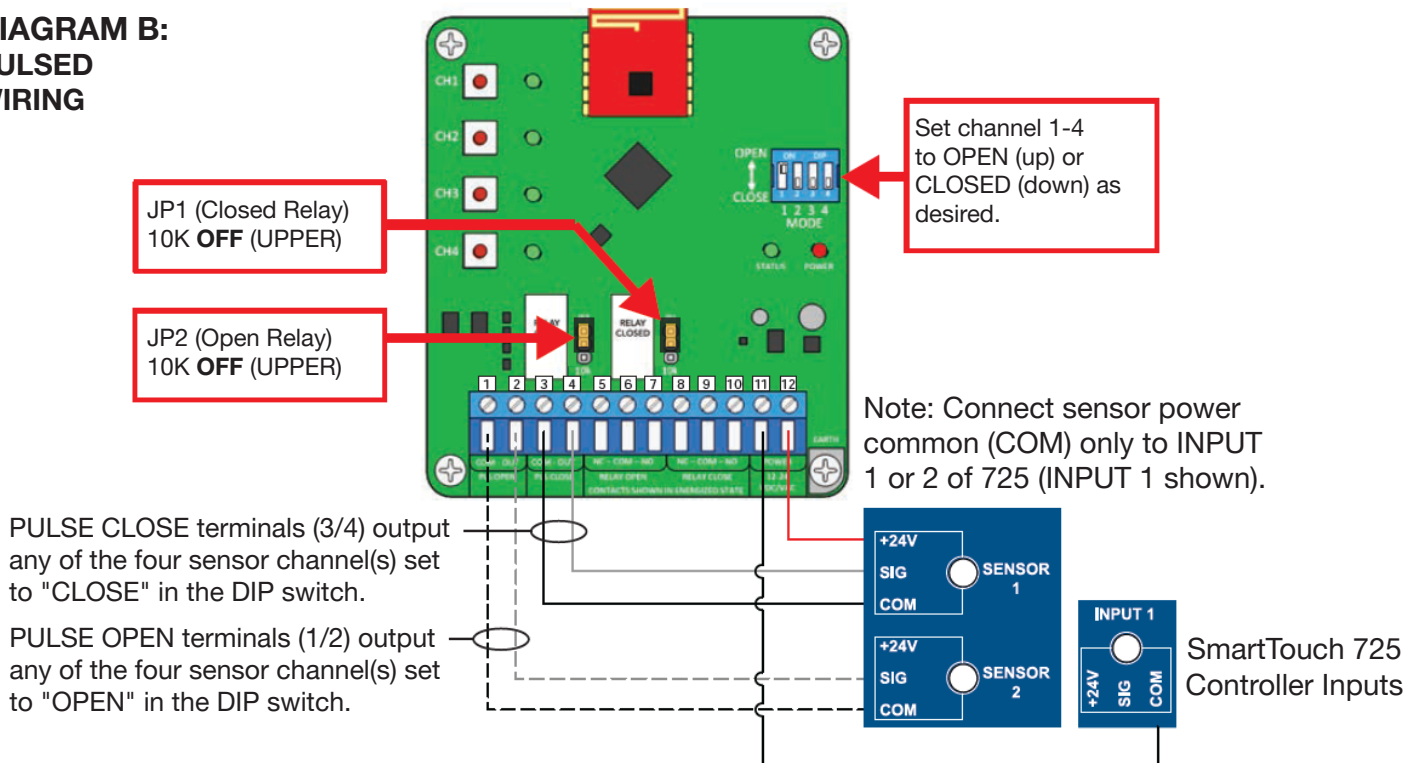
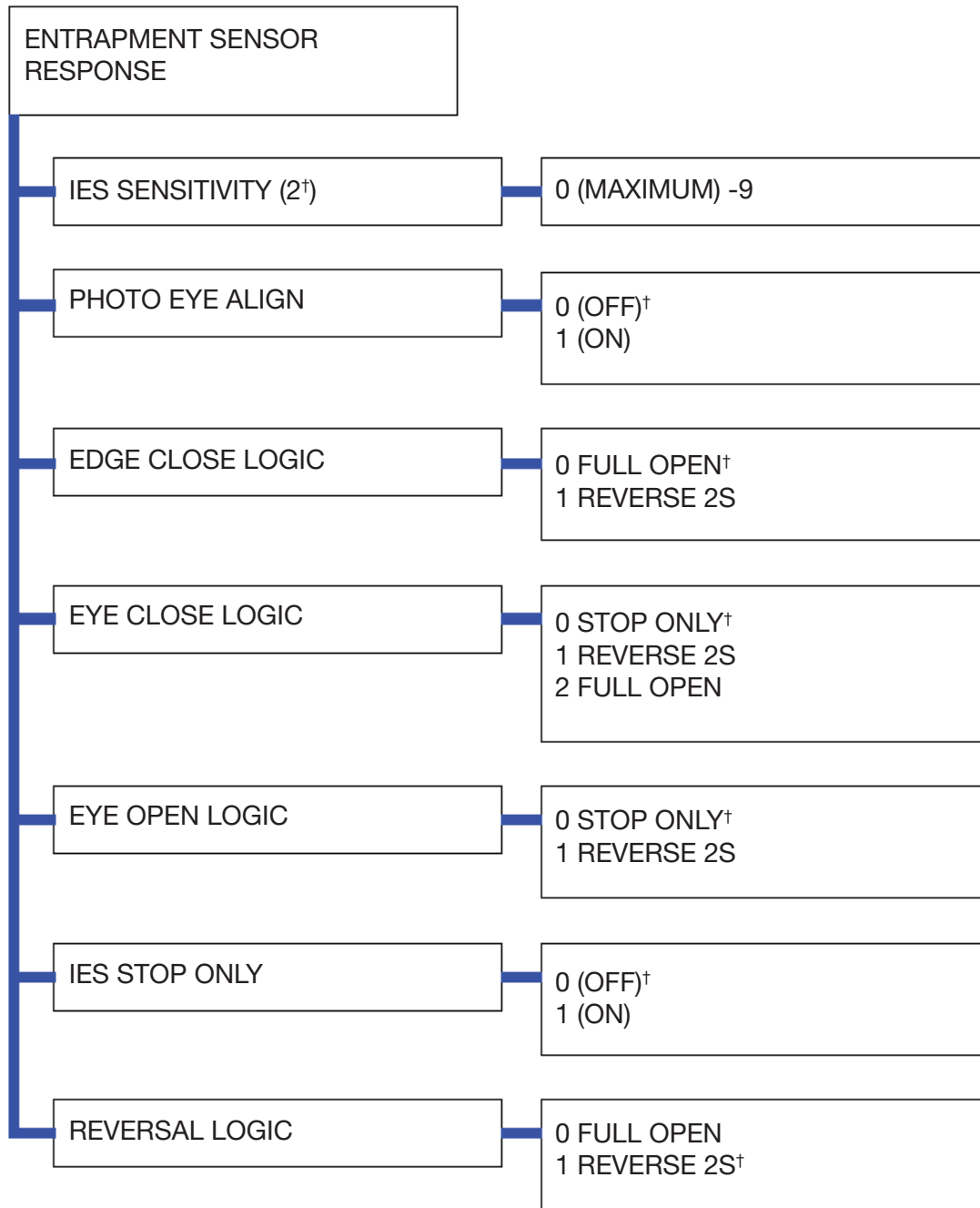

Figure 60. EMX WEL200 Wiring

# Entrapment Sensor Response



<sup>†</sup> = Indicates default

# Entrapment Sensor Response

**Table 14. Smart 535 Operator Configurations Settings**

MENU DISPLAY	SETTINGS	DESCRIPTION
IES SENSITIVITY	0 (MAXIMUM) 1 <b>2 (DEFAULT)</b> ... 9 (MINIMUM)	Adjusts the sensitivity of the internal inherent entrapment sensor (IES). Available settings are 0 to 9 with 0 being the most sensitive. HySecurity strongly recommends that you avoid setting the IES sensitivity higher than 6.  Note: Before changing the IES sensitivity, make sure that the gate moves smoothly without obstruction. Fix any issues with gate hardware.
PHOTO EYE ALIGN	<b>0 = OFF</b> 1 = ON	When set to 1, operator assists photo eye alignment. Buzzer chirps once when transmitter and receiver are not aligned. When transmitter and receiver are aligned, buzzer chirps twice. If they go out of alignment again or if beam is blocked, buzzer will chirp once.  Also, when set to 1, the display will show all the sensor inputs that are programmed for photo eyes and will show if they are active or not (a 1 indicates the eye is present and aligned and a 0 indicates the eye is not aligned or blocked). Any BlueBus eye will also show up on the display.  PHOTO EYE ALIGN changes to OFF on the next limit contact, reset, or power cycle.
EDGE CLOSE LOGIC	<b>0 = FULL OPEN</b> 1 = REVERSE 2S	Default setting is a full-open reversal if Gate Edge Close or Edge Both is triggered while closing. Optional setting of 1 causes gate to reverse for two seconds if triggered while closing. Gate Edge Open will reverse to full close when all open inputs and loop detectors are not active. There is no adjustment to Gate Edge Open reversal.
EYE CLOSE LOGIC	<b>0 = STOP ONLY</b> 1 = REVERSE 2S 2 = FULL OPEN	Default setting is non-reversal if Photo Eye Close is triggered while closing. A setting of 1 causes gate to reverse toward open for two seconds if triggered while closing. A setting of 2 reverses the gate to full open.
EYE OPEN LOGIC	<b>0 = STOP ONLY</b> 1 = REVERSE 2S	Default setting is non-reversal if Photo Eye Open is triggered while opening. A setting of 1 causes gate to reverse toward close for two seconds if triggered while opening.
IES STOP ONLY	<b>0 = OFF</b> 1 = ON	In a Usage Class 4 environment, operator can be set to stop only, and not reverse gate travel after an IES trip.
REVERSAL LOGIC	0 = FULL OPEN <b>1 = REVERSE 2S</b>	Sets the reversal logic for IES response. Default is reverse for 2 seconds. Set to 0 for full open.

# Set IES Sensitivity

To comply with UL 325 Safety Standards, HySecurity operators are equipped with a Type A, Inherent Entrapment Sensor (IES). The IES firmware monitors the average motor current when a gate is in motion and reverses direction of gate travel when the current exceeds a self-adapting threshold.

A spike in motor current can be caused by the gate hitting a pedestrian, a collision with a vehicle, failing gate hardware, extreme wind gust, or any other force applied against the moving gate.

## To set the IES sensitivity for your site, follow these instructions:

1. Press MENU on the SmartTouch 725 Controller.
2. Press the UP or DOWN arrow to navigate to ENTRAPMENT SENSOR RESPONSE, press SELECT.
3. Press the UP or DOWN arrow to navigate to IES SENSITIVITY, press SELECT.
4. Press the UP or DOWN arrow to choose an IES SENSITIVITY, press SELECT to update the setting.

### WARNING

In order to minimize risk of injury, use the lowest IES Sensitivity setting that results in reliable operation.

Note: Settings 0-8 are adaptive and setting 9 is fixed.

5. Press BACK until the display shows the operator status (Open, Close, or Stop).
6. Run the operator for 3 uninterrupted gate cycles so the IES can adapt to the new setting.
7. To test IES sensitivity, apply force to the moving gate with an immovable obstruction to trigger the IES. Gate will stop motion and reverse for two seconds. "SAFE MODE" appears on the display.

### WARNING

Do not risk injury by using any part of your body to test IES Sensitivity.

8. If the IES sensitivity requires adjustment based on performance or safety concerns, repeat steps 1-7.

Note: In Safe Mode, the automatic close timer is disabled, but any open or close input restarts gate motion. Safe Mode clears when full travel reached or Reset button pushed.

Note: A second IES trip before Safe Mode is cleared, results in an Entrapment Mode Alert which can be cleared with a Reset on the controller, an open input, stop input, or stop button on operator cover.

See "Entrapment Sensor Response" on page 61.

# User Relay Outputs

**Table 15. SmartTouch 725 User Relay Outputs Settings**

MENU DISPLAY	SETTINGS	DESCRIPTION
RELAY 1-3 LOGIC	0 = DISABLED 1 = CLOSE LIMIT 2 = CLOSE PULSE 3 = OPEN LIMIT 4 = OPEN PULSE 5 = WARN B4 OP 6 = GATE LOCK 7 = FORCE OPEN 8 = OPEN 2 LONG 9 = SAFE MODE 10 = ENTRAPMENT 11 = TAILGATER 12 = OUTSIDE LOOP 13 = LOITERING 14 = NEAR LIMIT 15 = ALERT/FAULT 16 = MOTOR RUNNING 17 = AC POWER LOSS 18 = LOW BATTERY 19 = FLASHER 20 = EXIT LOOP 21 = INSIDE LOOP 22 = CENTER LOOP 23 = PRISON LOCK 24 = PARTIAL OPEN 25 = BATTERY OK 26 = EXIT PULSE 27 = NOT OP AC 28 = FLASH AC 29- 40 = PARKING ARM OPERATORS ONLY 41 = TEST OPEN 42 = NOT USED 43 = WARN THRU 44 = POL PULSE 45 = OUTS CLOSE 46 = TIMER OPEN 47 = OXI ACCESSORY 48 = OXI ACC/1-MIN 49 = BELOW 45 DEGF 50 = MODBUS RELAY	See Table 16
RELAY 4-11 LOGIC	SEE RELAY 1 LOGIC SETTINGS (0)	See Table 16

# User Relay Outputs

**Table 16. User-Programmable User Relays - Function Options**

No.	Name	Description
1	Close limit output	Creates an interlock signal to another operator's interlock input, or simply to indicate that gate is secure or not. Relay is released when fully-closed limit switch is tripped. Relay is energized when fully-closed limit is released. (Any open command energizes relay.)
2	Close limit pulse output	Used in a sequenced system to command a second machine to close. Generates a brief pulsed output that occurs when close limit is triggered.
3	Open limit output	Indicates gate is at full-open position. Output becomes active when an open-limit is triggered and deactivates when open-limit is released or a close command is received. Use this output for a traffic light.
4	Open limit pulse output	Triggers a sequenced barrier arm gate operator to open. Generates a brief pulsed-output when open-limit is triggered. An additional pulse is also generated with any new open command even when gate is already fully-opened.
5	Warn before/during operate output	Controls an external warning device. This output is active whenever internal warn before operate buzzer is sounding but the relay output is constant on. Activation timing of this relay is controlled by setting Warn Before Operate.
6	Gate Lock output	Controls external solenoid locks or magnetic locks. In both directions of travel, this output is activated about 7/10ths of a second before operator starts moving the gate.
7	Gate forced open output	Activated if gate is forced off closed limit switch and operator is not able to restore gate to full closed position within four seconds. The buzzer resets itself in 30 seconds but relay stays active until gate receives a run command.
8	Gate open too long output	Activates when gate is open longer than the user-selected period of time. Adjustable from a 0 second to 15 second to 135 seconds delay in 30-second increments. Note: OPEN TIME ALERT adjustments can be made in the menus.
9	Safety Mode Alert output	Activated when system is in Safety Mode or Entrapment Mode. Safety Mode occurs upon an impact with an obstruction. Entrapment Mode means gate is stopped and occurs if inherent entrapment sensor triggers or if emergency input is activated while system is in Safety Mode.
10	Entrapment Mode Alert output	Activated only when system is in Entrapment Mode.
11	Unauthorized Vehicle Entry output	Activated when a second vehicle enters from outside without a valid input from an access control device. The OOLD and IOLD loops must be capable of being triggered at the same time for this relay to ever activate. This output releases when an access control input signals open or gate reaches the close limit position.
12	Outside Obstruction Vehicle Detector output	This output is active whenever Outside Obstruction Loop Detector is tripped. Interlocks an entry device to prevent pedestrian use.
13	Loitering Alert	Indicates vehicle is loitering on Outside Obstruction Loop with the gate closed. Adjustable from a 0 second to 15 second to 135 second delay in 30-second intervals. Note: LOITERING ALERT adjustments can be made in the menus.
14	Gate nearing full travel output	Activated when gate is approaching full open or full closed. Relay activates three feet from where software expects limit switch to be triggered whether moving toward full open, full close, or in a reverse travel mode.
15	Gate Failure output	Activated to report occurrence of problem. Indicates the system is in an Error, Fault, Alert, or Entrapment Mode. If active, gate is disabled.
16	Motor Running output	Active when motor is running and gate is in motion.

Note: Function Options table continues on next page.

# User Relay Outputs

**Table 16. User-Programmable User Relays - Function Options**

No.	Name	Description
17	AC Power Failure output	This relay is normally energized and drops with loss of AC power.
18	DC Power Failure output	Activated when battery power is very low, but output ceases when battery is dead (18 volts). Relay is triggered when battery is less than 21 volts.
19	Flasher Relay	Controls flashing lights to pulse once per second. Relay is constantly pulsing except when open limit switch is triggered. Recommended to use User Relay 2 or 3 since it is an electronic switch.
20	Free Exit Loop Vehicle Detector output	Active whenever Exit Loop is tripped.
21	Inside Obstruction Vehicle Detector output	Active whenever Inside Obstruction Vehicle Detector is tripped
22	Center Loop Detector output	Active whenever Center (Shadow) loop detector is tripped.
23	External Latching Gate Lock Output	Not functional in SwingSmart 535 operators.
24	Gate at Partial Open Position	Active when partial open position is reached or exceeded. (Slide gates only)
25	DC Power Alert	Active when on AC power or the battery voltage is above 21V. When used with User Relay 2, this option can shed electrical loads to conserve battery energy.
26	Free Exit Loop Detector pulse	Outputs a 250ms pulse when the free exit vehicle detector is tripped.
27	Not Open (w/ AC power)	Activated when gate is not on open limit and AC power is present. Deactivated when AC power fails or gate is on open limit.
28	Flasher (w/ AC power)	Output identical to relay #19 and pulses relay 500 ms/sec when gate not on open limit and AC power is present. Deactivated when AC power fails or gate is on open limit.
29	Arm Entry Ticket Dispenser	Not used.
30	Arm Exit Ticket Dispenser	Not used.
31	Resert Ticket Dispenser Pulse	Not used.
32	Backoff Pulse	Not used.
33	Transient In Pulse	Not used.
34	Transient Out Pulse	Not used.
35	Tenant In Pulse	Not used.
36	Tenant Out Pulse	Not used.
37	Special In Pulse	Not used.
38	Special Out Pulse	Not used.
39	Unknown In Pulse	Not used.
40	Unknown Out Pulse	Not used.
41	Test Open Pulse	Output pulses five seconds after close limit is activated. Typically used for cycle testing.
42	Break-Away Switch Output	Not used.
43	Warn Before	Combination of relays #5 and #16.
44	Partial Open Limit Pulse	Pulses for 250ms when gate, commanded with Partial Open input, reaches Partial Open Limit, or, gate is past Partial Open Limit and Partial Open input is activated.

Note: Function Options table continues on next page.

# User Relay Outputs

**Table 16. User-Programmable User Relays - Function Options**

No.	Name	Description
45	Outside Obstruction/Arming Loop Detector	Activated when OOLD/OALD detector input tripped and gate closed. Used for testing purposes.
46	Timer Open	Relay activates when 7 day timer is programmed and the timer is active.
47	OXI Accessory	Latching output controlled by an OXI remote. When pairing a remote, a button can be programmed to energize a relay and latch it until the button is pressed a second time.
48	OXI Accessory/1-min	Output controlled by an OXI remote. When pairing a remote, a button can be programmed to energize a relay and latch it for 1 minute or until the button is pressed a second time, whichever comes first.
49	Below 45 DegF	Relay turns on when the board temperature is detected to be below 45 degrees Fahrenheit. The relay turns on an optional heater in the operator when external ambient temperature approaches freezing. Relay turns heater off when the temperature increases above 45 degrees Fahrenheit.
50	Modbus Relay	This relay output can be controlled to turn on or off when the operator is communicating with an access control system via ModBus communication.

# Relay Outputs - Basic

The three relays on the SmartTouch 725 Controller are configurable to perform a wide range of options for integration with external devices.

- Accessory power limited to 2A at 24VDC across all inputs and relays.
  - Relay capacity: (1) Mechanical 20A max at 240VAC (Figure 62, Relay 1). (2) Solid state relays 30VDC, 2A max (Figure 62, Relay 2 & 3).
1. Install the relay controlled device according to the manufacturer's instructions.
  2. Route the relay wires to the SmartTouch 725 Controller (Figure 61).

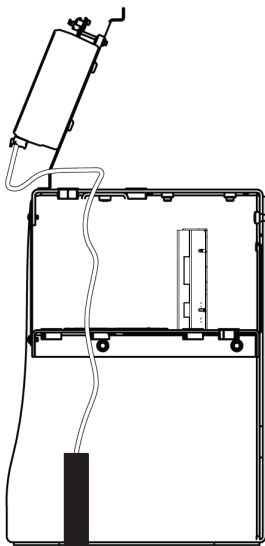

Figure 61. Route Relay Wires

3. Install the relay wires in the appropriate relay terminal(s): mechanical (Relay 1) or solid state (Relay 2 and 3) (Figure 62).

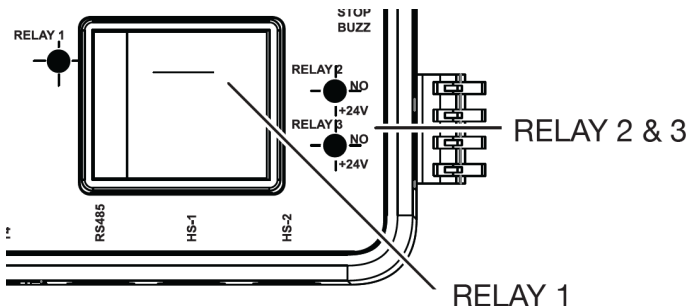
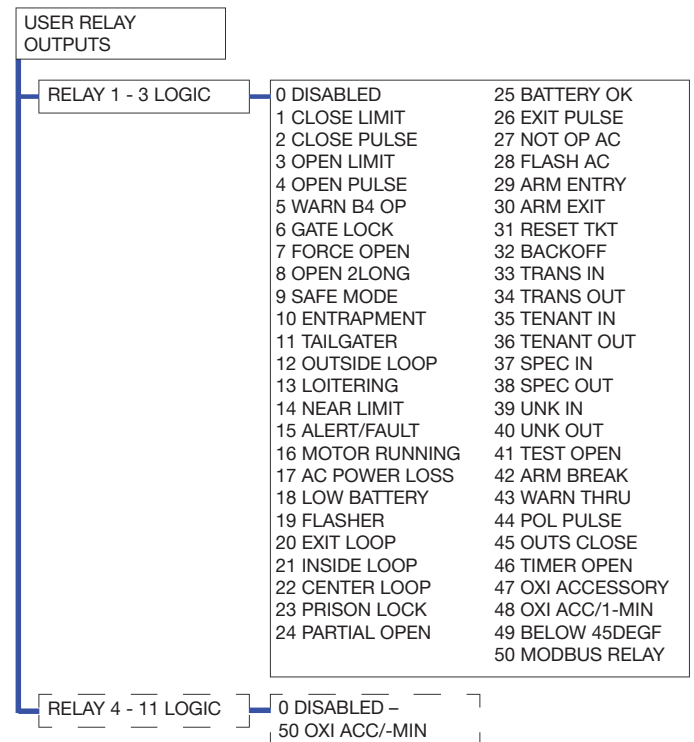

Figure 62. Relay Terminals

4. Press MENU on the SmartTouch 725 Controller.
5. Press the UP or DOWN arrow to navigate to USER RELAY OUTPUTS, press SELECT.

6. Press the UP or DOWN arrow to navigate to RELAY LOGIC, press SELECT.
7. Press the UP or DOWN arrow to highlight the appropriate setting, press SELECT.
8. Press BACK until the SmartTouch 725 Controller resets and operator status displays.



Note: Relay 4-11 are visible and configurable only with optional I/O expansion module which connects via communication cable (MX4330 in the I/O expansion module kit) from HS-2 on the SmartTouch 725 Controller to HS-A on the I/O expansion module.

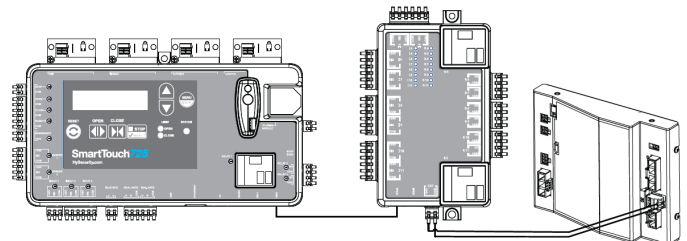

# Relay Outputs - Mechanical

Maglocks and solenoids are common examples of relay driven devices used with gate operators to increase security. Follow these instructions to connect a maglock or solenoid to the SmartTouch 725 Controller:

1. Follow manufacturers instructions to install and position the relay driven device.
2. Set the AC and DC switches to OFF.
3. Connect COM on RELAY 1 to any COM terminal on the SmartTouch 725 Controller. HySecurity recommends Input 3 COM.
4. Connect the power lead from the maglock or solenoid to power. You can pull +24VDC from anywhere on the controller labeled +24V.

5. For a maglock, connect to the NC connector on RELAY 1. For a solenoid, connect to the NO connector.
  6. Set the AC and DC switches to ON.
  7. Press MENU on the SmartTouch 725 Controller.
  8. Use the UP or DOWN button to navigate to USER RELAY OUTPUTS and press SELECT.
  9. Use the UP or DOWN button to navigate to RELAY 1 LOGIC and press SELECT.
  10. Use the arrow buttons to navigate to 6 GATE LOCK and press SELECT.
  11. Press BACK until gate status display appears.
- Note: Relay 1 can handle up to 240VAC for external power source use.

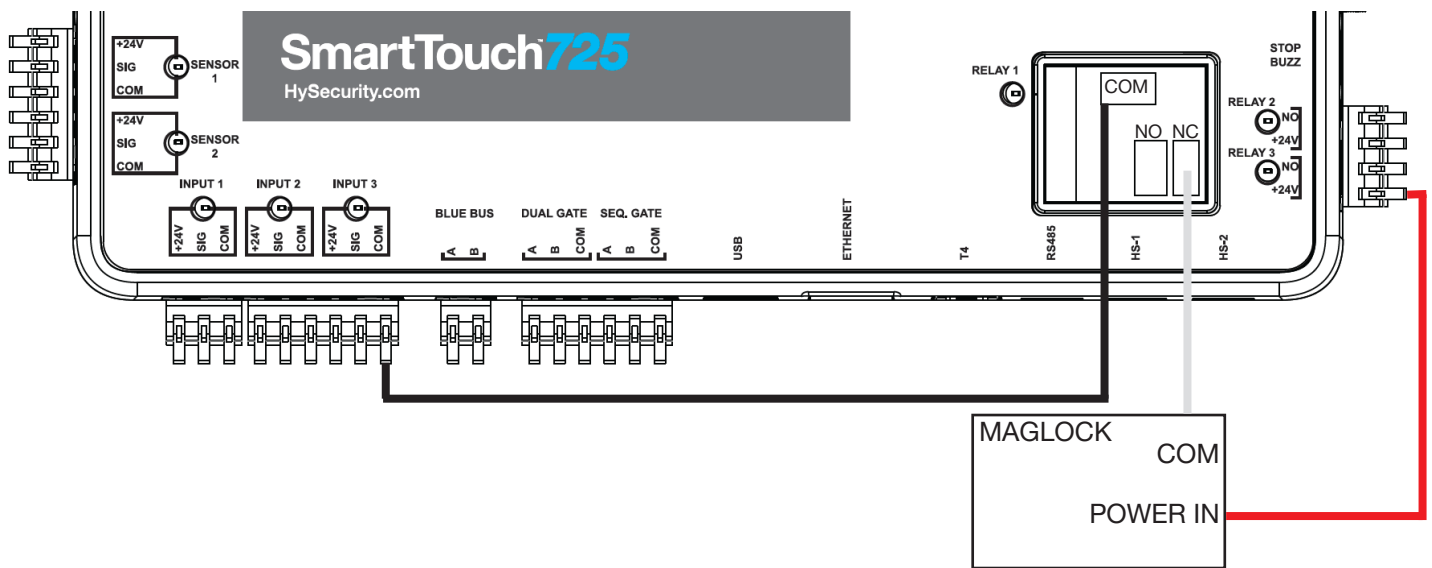

Figure 63. Maglock Wiring Example. For Solenoid Connect Solenoid COM to Relay 1 NO.

# Relay Outputs - Solid State

Solid state relay (Relay 2 and Relay 3) wiring diagrams.

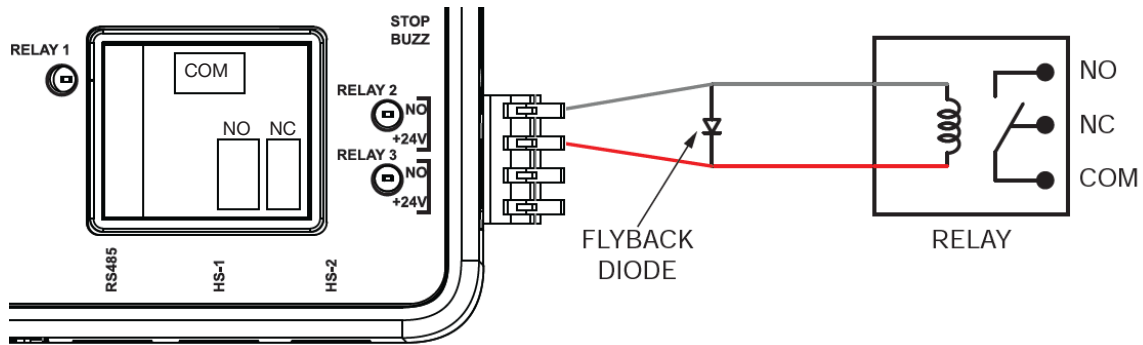

Figure 64. Wiring a 24V Accessory

Note: A flyback diode protects the SmartTouch 725 Controller from voltage spikes caused by switching the coil in the relay. HySecurity recommends a 1n4007 diode for use with most accessories.

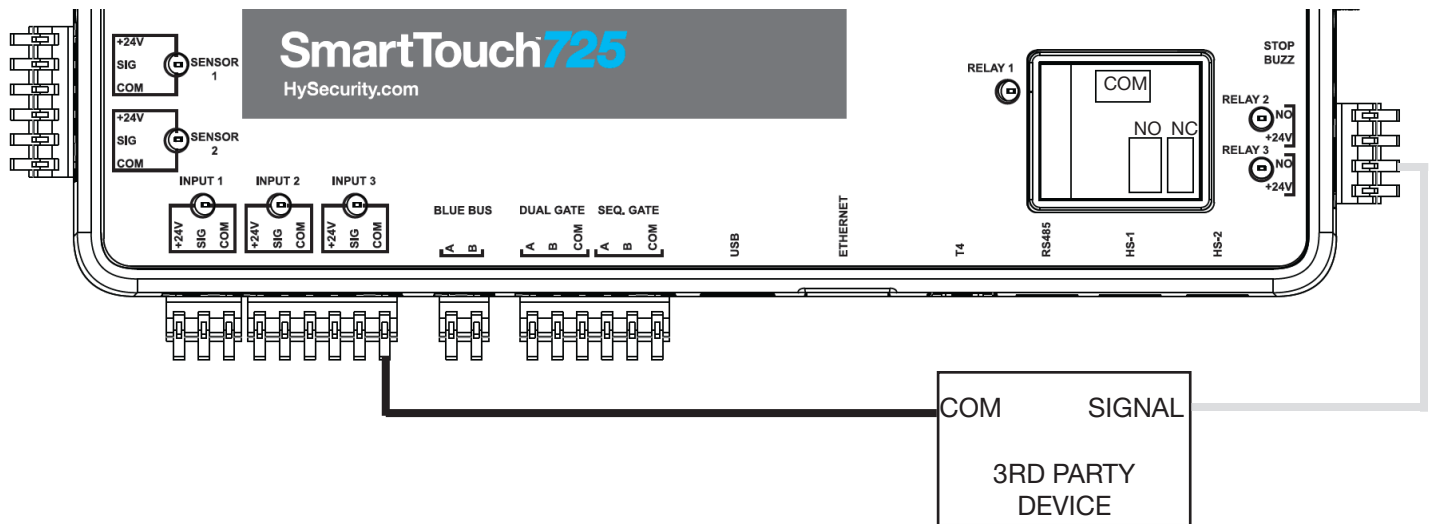

Figure 65. Wiring a 3rd Party Device

Note: Relay 2 and Relay 3 on the SmartTouch 725 Controller use a switched common signal when the relay is triggered.

Note: Relay 2 and Relay 3 can only handle up to 24VDC.

# SmartTouch 725 - HY5B Module

## INSTALL AN HY5B AND VEHICLE LOOP DETECTOR

There are 4 Hy5B ports on the SmartTouch 725 Controller: Free Exit, Outside Obstruction, Inside Obstruction, and Center. Refer to "Vehicle Detector Loop Layouts" on page 48 for standard loop layout illustrations.

1. Route the loop detector wires through the operator chassis to the SmartTouch 725 Controller.
2. Switch off AC and DC power.
3. Connect the wires to the Hy5B module.
4. Plug the Hy5B into the appropriate port (remove rubber plug).
5. Use zip ties and the holes in the aluminum controller bracket to neatly organize the loop lead wires to keep wires out of the way and prevent them from moving.
6. Switch on AC and DC power. The display will show loop detectors 'Initializing'.
7. In LOOP OPTIONS menu, configure the appropriate loop detector settings.

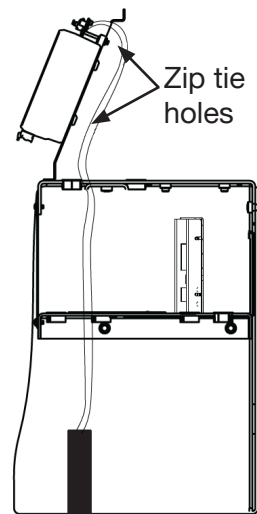
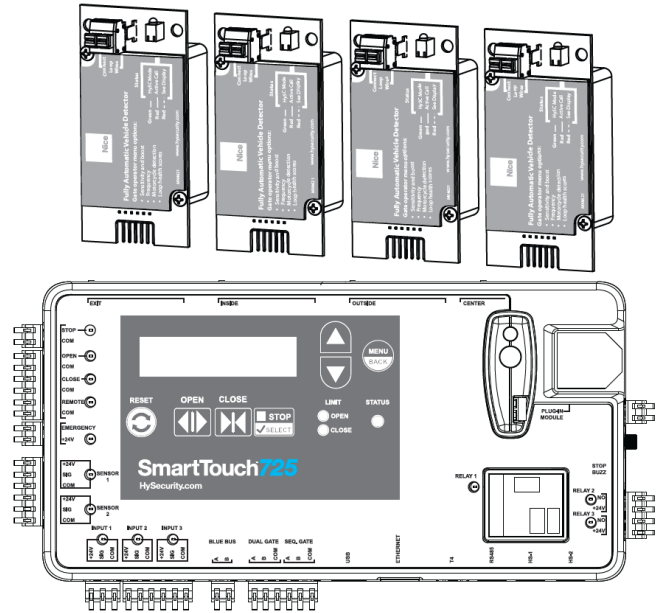

# Loop Options

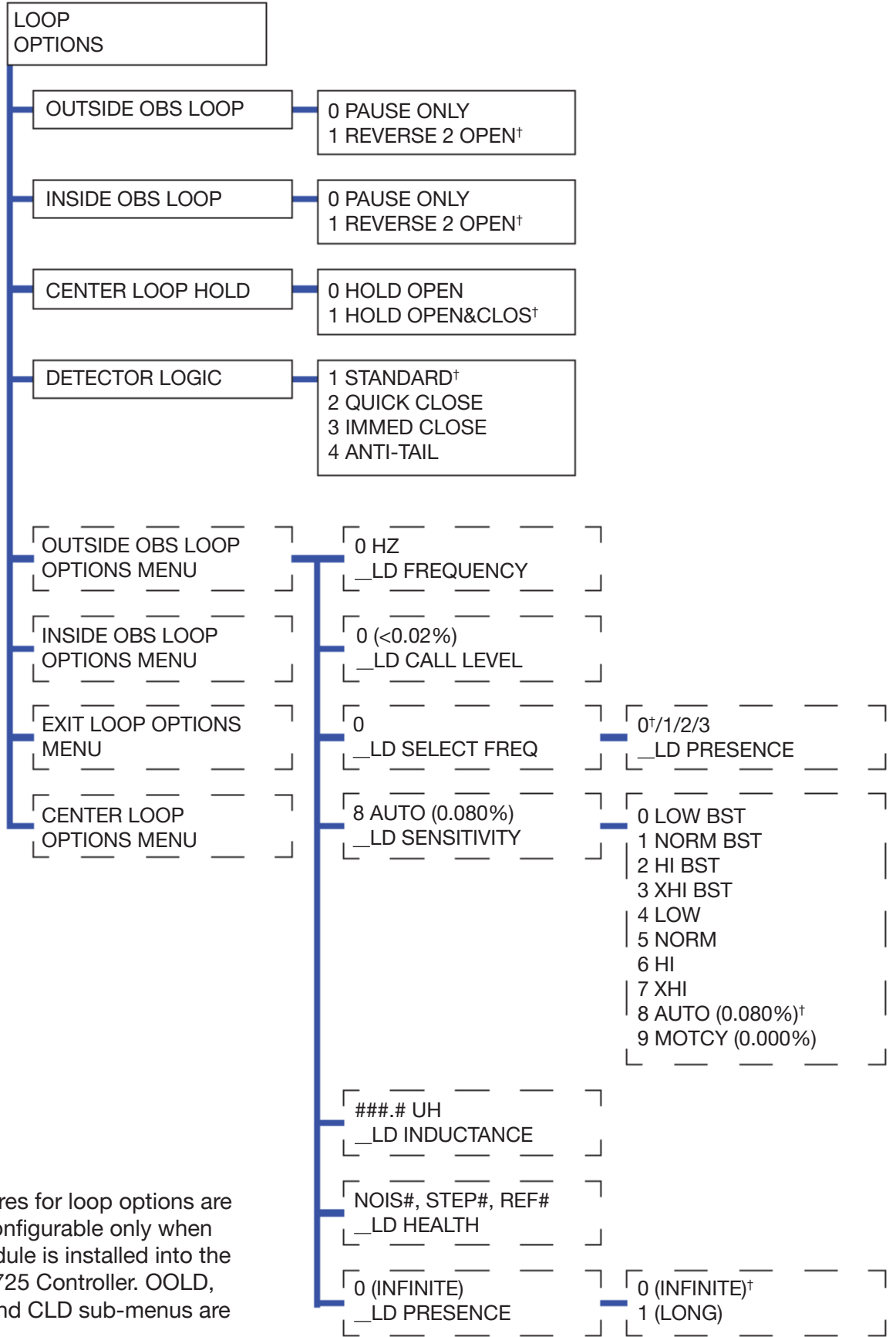

Note: Menu structures for loop options are visible and configurable only when an HY5B module is installed into the SmartTouch 725 Controller. OOLD, IOLD, ELD, and CLD sub-menus are identical.

† = Indicates default

# Loop Options

**Table 17. SmartTouch 725 Loop Options Settings**

MENU DISPLAY	SETTINGS	DESCRIPTION
OUTSIDE OBS LOOP	0 = PAUSE ONLY 1 = <b>REVERSE 2 OPEN</b>	Default is for full reversal when Outside Obstruction Loop is triggered while closing. A setting of 0 causes gate to only pause when triggered. Gate closure continues as soon as loop is clear again.
INSIDE OBS LOOP	0 = PAUSE ONLY 1 = <b>REVERSE 2 OPEN</b>	Default is for full reversal when Inside Obstruction Loop is triggered while closing. A setting of 0 causes gate to only pause when triggered. Closure begins as soon as loop is clear again.
CENTER LOOP HOLD	0 = HOLD OPEN 1 = <b>HOLD OPEN&amp;CLOS</b>	Swing only. When set to 1, an active center loop will prevent a full open gate from closing and a full closed gate from opening. When set to 0, an active center loop will prevent a full open gate from closing and will have no effect on a closed gate. The center loop has no effect on a gate that is in between limits or a slide gate.
DETECTOR LOGIC	1 = <b>STANDARD</b> 2 = QUICK CLOSE 3 = IMMED CLOSE (SLIDE ONLY) 4 = ANTI-TAIL (SLIDE ONLY)	This selection determines whether close timer begins to count down after vehicles have departed detector loops or whether close timer will count down while the loops are occupied. Gate can only close when all loop detectors are clear.  Default settings causes Close Timer to start when all loops are clear. A setting of 2 causes Close Timer to start when open limit is reached. A setting of 3 forces the Close Timer to 0 when the OOLD and IOLD are tripped simultaneously (SLIDE ONLY). A setting of 4 stops the gate when OOLD and IOLD are tripped simultaneously and closes from that point when the loops clear (SLIDE ONLY).
Note: Loop Options Settings table continues on next page.		

# Loop Options

**Table 17. SmartTouch 725 Loop Options Settings**

MENU DISPLAY	SETTINGS	DESCRIPTION
OUTSIDE OBS LOOP OPTIONS MENU		
__LD FREQUENCY		Displays the outside obstruction loop detector frequency
__LD CALL LEVEL		Displays the outside obstruction loop detector call level
__LD SELECT FREQ	0-3	Set the outside obstruction loop detector frequency 0-3
__LD SENSITIVITY	0 = LOW BST 1 = NORM BST 2 = HI BST 3 = XHI BST 4 = LOW 5 = NORM 6 = HI 7 = XHI <b>8 = AUTO (0.080%)</b> 9 = MOTCY	Set the loop detector sensitivity. Settings 0-3 are with boost which will "boost" the sensitivity while in call state to not lose detection of a high-bed vehicle as it passes over the loop.  Note: Automatic Gate Compensation (AGC) can be disabled while in the Hy5B loop menu. In the menu, hold the reset button for 3 seconds. The AGC menu will appear where it can be turned on or off with the arrow buttons and select button.
__LD INDUCTANCE		Displays the outside obstruction loop detector inductance
__LD HEALTH		Displays the outside obstruction loop detector health
__LD PRESENCE	<b>0 = INFINITE</b> 1 = LONG	INFINITE = A site where standing or parked vehicular traffic (on large area loops) is a daily or consistent basis, INFINITE presence setting is a viable option. When loop may have vehicles parked on it for more than several hours and it must hold the call, set presence to INFINITE.  LONG = With sensitivity set to A (AUTO) and a large sedan stationary on loop, LONG presence may hold call for many hours before vehicle's presence is tuned out. Then, stationary vehicle is ignored and unaffected portion of loop becomes operational. In contrast, with sensitivity set to M (MOTORCYCLE), default threshold only lasts about 1 hour before presence of motorcycle on loop is tuned out.
INSIDE OBS LOOP OPTIONS MENU	SAME AS OUTSIDE LOOP OPTIONS MENU	
EXIT LOOP OPTIONS MENU	SAME AS OUTSIDE LOOP OPTIONS MENU	
CENTER LOOP OPTIONS MENU	SAME AS OUTSIDE LOOP OPTIONS MENU	

# SmartTouch 725 - HY5B Loop Diagnostics

**Table 18. Loop Noise Score**

Score	Meaning	Possible Impact on Gate Operation
7	Near perfect, no discernible noise	None
6	Very slight noise	None
5	Some noise	Not likely - Holding detects
4	Enough noise to be a concern	Not likely - False detects, holding detects
3	Noise probably impacting operation	Likely - False detects, holding detects
2	Significant noise	Likely - False detects, holding detects, will not reset
1	Very significant noise	Very likely - False detects, holding detects, will not reset
0	Severe noise	Very likely - False detects, holding detects, will not reset

**Table 19. Loop Step Changes Score**

Score	Meaning	Possible Impact on Gate Operation
7	No step changes recorded	None
6	One step change recorded	Possible - False detects, locked in call
5	2 to 3 step changes recorded	Likely - False detects, locked in call
4	4 to 5 step changes recorded	Likely - False detects, locked in call
3	More than a few step changes recorded	Very likely - False detects, locked in call
2	Significant number of step changes recorded	Very likely - False detects, locked in call
1	Very significant number of step changes recorded	Very likely - False detects, locked in call
0	Severe number of step changes recorded	Very likely - False detects, locked in call

**Table 20. Loop References Changes Score**

Score	Meaning	Possible Impact on Gate Operation
7	Very stable reference	None
6	Stable reference	None
5	Edge of normal temperature swing	None
4	Wide temperature swing	Not likely - False detects
3	Edge of effects due to any temperature swing	Not likely - False detects
2	Significant reference movement	Possible false detects
1	Very significant reference movement	Possible false detects
0	Severe reference movement	Possible false detects

# SmartTouch 725 - HY5B Loop Diagnostics

## Possible Causes of Loop Noise:

- Inductively-Coupled Loop Cross-talk – This is interference between two or more active loops. If all detectors used are Hy5Bs, this is not the source of the noise as the operator turns on and off each detector in sequence to ensure that this type of cross-talk cannot occur. If you are experiencing this issue, installing all Hy5Bs will be the most effective mitigation technique. If this is not possible, changing the frequency of one or both of the loops that are interfering usually reduces the cross-talk to acceptable levels.
- Capacitively-Coupled Interference – This is interference between electrical wiring in close proximity to each other (usually in the same conduit) for significant distances (usually 50 feet or more). The longer the distance the more pronounced the effect. Twisting of the loop lead in wires will help with this. If a shielded cable is used for the loop wires, the shield of the cable should be left floating (unconnected) at both ends.
- Other Electrical Interference – This is usually interference that is coupled in to the loop, lead-in, or detector itself. Changing the loop frequency on the detector may help. If the interference is coupling in to the loop itself, a figure 8 loop may be needed to mitigate the source of interference. If the interference is at the detector, additional shielding may be needed.

## Possible Causes of Loop Step Changes:

- Loose Electrical Connections – If there are any splices in the loop wires, they should be checked. Wire nuts should never be used in loop connections and usually will create these types of issues. If there are splices, they should be soldered if possible or at the very least crimped.
- Failed Loop Wire Insulation – This normally occurs when there is a high moisture content in the air that condenses (rain, fog, or dew) and the loop wire insulation is damaged in some way and this moisture can wick its way to that failure point. Using a megaohm meter on the loop and getting a reading of less than 100 megaohms will usually this type of issue.

- Conductor Fatigue – If the loop is installed across a joint in the driving surface or the lead-in is exposed to significant vibration, the conductor in the wire may fatigue and change its resistance slightly when flexed. With this type of failure, the failed wire must be replaced.
- Objects Embedded in the Saw Slot – It is possible for objects (nails, screws, etc.) to become embedded in the saw slot sealant and over time get pressed down in to the loop wire (especially if good installation practices are not followed). Once this object touches a loop wire conductor, the loop must be replaced.

## Possible causes of loop reference changes:

- Wide Temperature Swings – The reference within the detector will change with temperature. If there are wide temperature swings during a 24-hour period, this score will go down and is expected and normal. The detector is designed to deal with ambient temperature changes of 2°F every minute. Rates of change faster than that may cause false detections (this usually only occurs if the cabinet is opened). If you are in an area that sees quick temperature changes (hot or cold), some insulation around the detectors may help.
- Temperature Sensitivity – It is possible that some of the components on the detector are abnormally temperature sensitive.

Note: Refer to Hy5B User and Reference Guide (MX4125) for full information about Hy5B vehicle detectors.

# External Communications

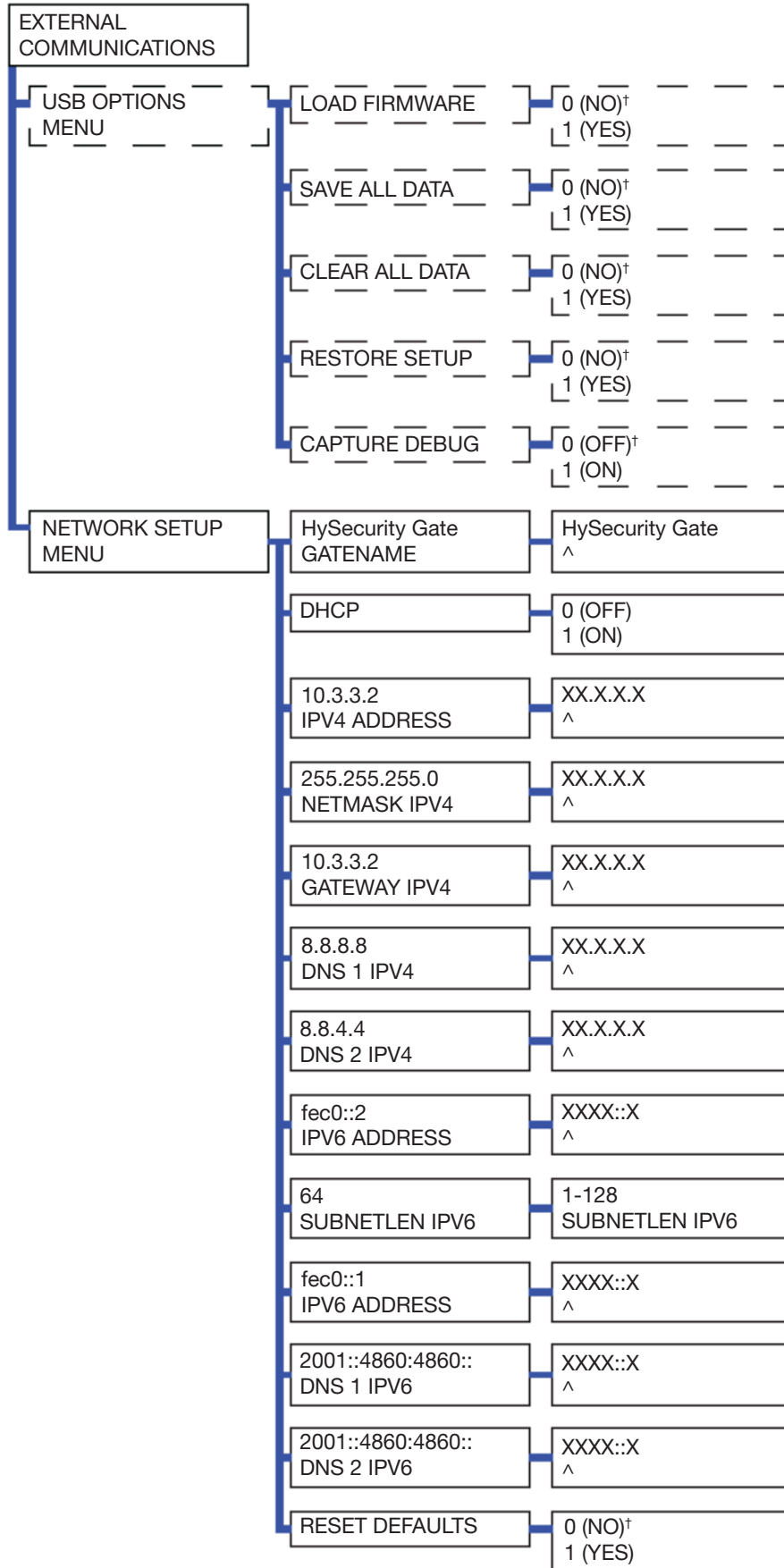

<sup>†</sup> = Indicates default

# External Communications

**Table 21. SmartTouch 725 External Communications Settings**

MENU DISPLAY	SETTINGS	DESCRIPTION
USB OPTIONS MENU		USB options submenu, only appears when a USB drive is connected to the SmartTouch 725 Controller.
LOAD FIRMWARE	0 = OFF 1 = ON	Set to ON after plugging in a USB drive with firmware updates to load new firmware.
SAVE ALL DATA	0 = NO 1 = YES	Saves the event log data, any stored debug data events, and the menu setup file.
CLEAR ALL DATA	0 = NO 1 = YES	Clears the event log and any stored debug data.
RESTORE SETUP	0 = OFF 1 = ON	Loads a saved menu setup file onto a new 725 controller or operator.
CAPTURE DEBUG	0 = OFF 1 = ON	Saves real time debug data onto a USB drive until the setting is changed to 1 (ON) or the stop button is pressed. The debug data can be used to determine if there are any intermittent input activations.
NETWORK SETUP MENU*		Network setup submenu
HYSECURITY GATE GATE NAME	HySecurity Gate ^	Set the name of the operator. Default name includes a four digit number for easy identification when pairing with bluetooth.
DHCP	0 = OFF 1 = ON	Used to assign dynamic IP addresses to devices on a network.
IPV4 ADDRESS	XX.X.X.X ^	IP address on IPv4
NETMASK IPV4	XXX.XXX.XXX.X ^	Subnet mask on IPv4
GATEWAY IPV4	XX.X.X.X ^	Gateway on IPv4
DNS 1 IPV4	X.X.X.X ^	Domain Name System address 1 on IPv4
DNS 2 IPV4	X.X.X.X ^	Domain Name System address 2 on IPv4
IPV6 ADDRESS	XXXX::X ^	IP address on IPv6
SUBNETLEN IPV6	1-128 (64)	IPV6 prefix length
GATEWAY IPV6	XXXX::X ^	Gateway on IPv6
DNS 1 IPV6	XXXX::XXXX::XXXX:: ^	Domain Name System address 1 on IPv6
DNS 2 IPV6	XXXX::XXXX::XXXX:: ^	Domain Name System address 2 on IPv6
MAC ADDRESS	XXXXXX-XXXXXX	Manufacturer set Media Access Control address
RESET DEFAULTS	0 = NO 1 = YES	Reset network settings.

Note: External Communications menu continues on page 80.

\*The NETWORK SETUP MENU settings are for the built-in HyNet functionality. Contact an IT professional for assistance with these settings to connect to a network. The SmartTouch 725 Controller can also connect to a network through the RS485 port and a separate HyNet module.

# Firmware Updates and Debug Data

## Download the firmware to a USB drive:

1. Go to [support.hysecurity.com](http://support.hysecurity.com), click on Software, click SmartTouch 725 Code vh6.##, and click h.6.##.cnx to download the firmware file.

2. Connect a USB drive to your computer.

Note: FAT32 is the preferred file system for USB drives used for firmware updates.

3. Navigate to the download folder with the .cnx file.
4. Copy the .cnx file to the root folder of the USB drive.
5. Properly disconnect the USB drive.

## Install the firmware:

1. Move the gate to the open position to allow free flow of traffic. The SmartTouch 725 Controller ignores all inputs and outputs during the firmware update.
2. Plug the USB drive into the USB port on the SmartTouch 725 Controller (Figure 66).
3. Press SELECT when USB OPTIONS MENU appears.
4. Press the UP or DOWN arrow to LOAD FIRMWARE and press SELECT.
5. Press the UP or DOWN arrow to YES and press SELECT.
6. The display shows LOADING FIRMWARE while the firmware loads. It could take up to 10 minutes to load the firmware.

### NOTICE

Do not shut off power. Do not remove the USB or HSP1 communication cable during download. This can cause SmartTouch 725 Controller communication to stop and requires a SmartTouch 725 Controller replacement.

7. The display shows COMPLETE and the controller beeps once when the firmware loading ends.
8. Remove the USB drive.

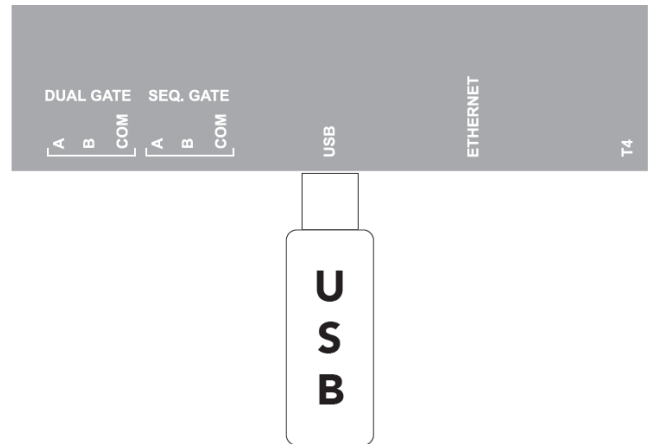
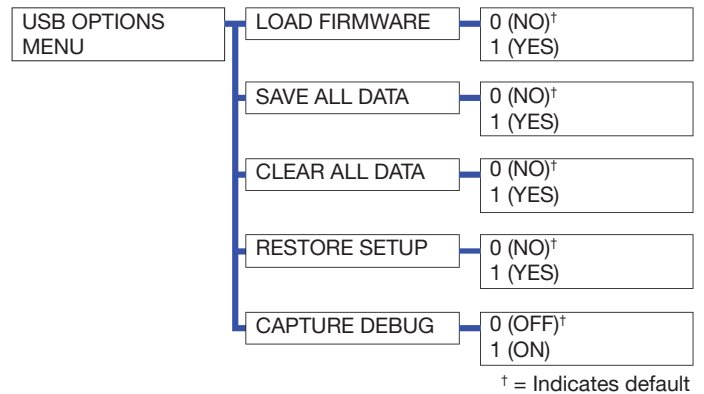

Figure 66. USB Port



LOAD FIRMWARE loads new firmware after plugging in a USB drive with firmware for updates.

SAVE ALL DATA saves the event log data, any stored debug data events, and the menu setup file.

CLEAR ALL DATA clears the eventlog and any stored debug data.

RESTORE SETUP loads a saved menu setup file onto a new 725 controller or operator.

CAPTURE DEBUG saves real time debug data onto a USB drive until the setting is changed to 1 (ON) or the stop button is pressed. The debug data can be used to determine if there are any intermittent input activations.

# External Communications

Continued from page 78.

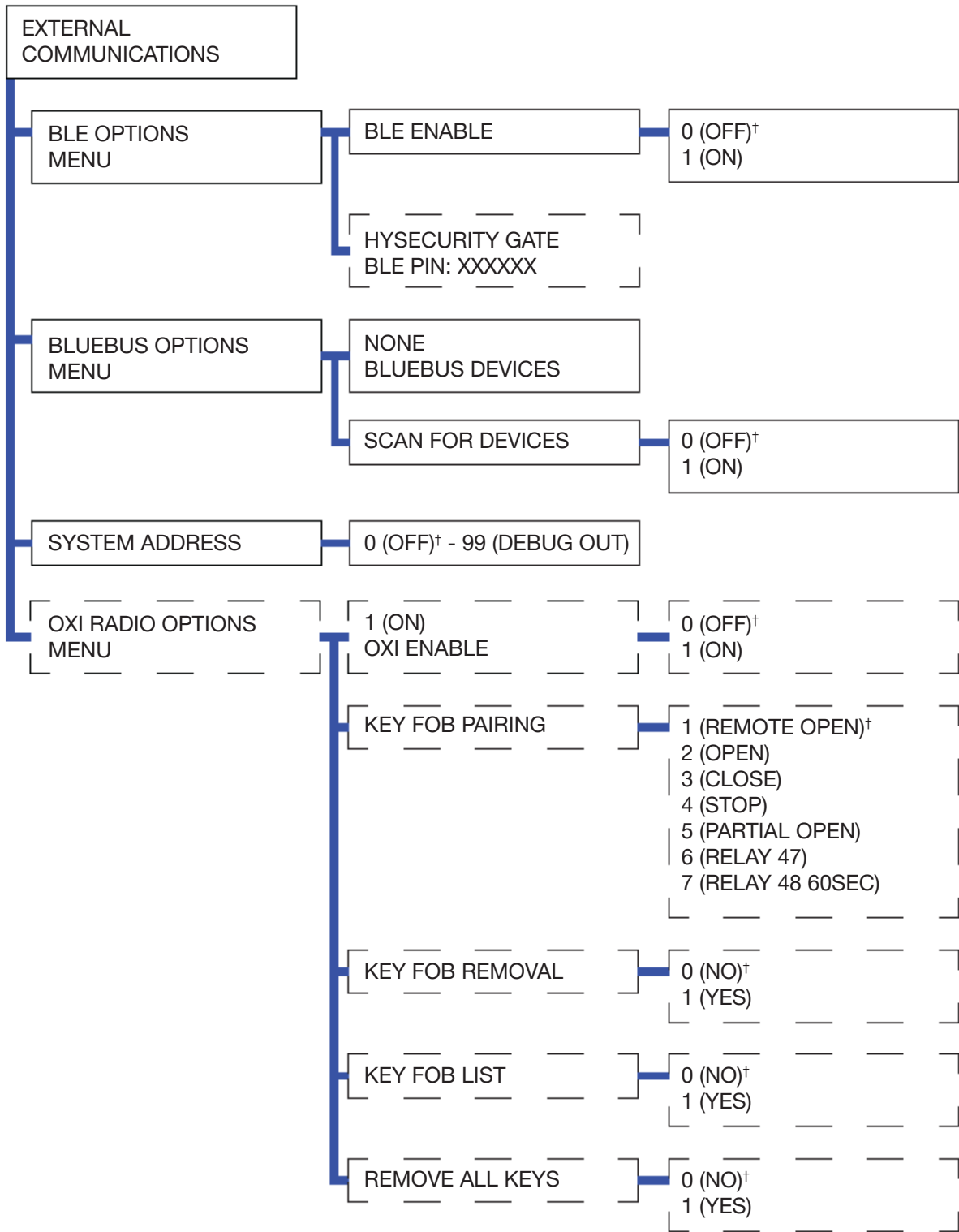

† = Indicates default

# External Communications

**Table 21. SmartTouch 725 External Communications Settings**

MENU DISPLAY	SETTINGS	DESCRIPTION
BLE OPTIONS MENU		Bluetooth low energy submenu
BLE ENABLE	<b>0 = OFF</b> 1 = ON	Enable or disable bluetooth low energy. Bluetooth logo will appear on gate status display.
HYSECURITY GATE PIN	XXXXXX	PIN to connect to the SmartTouch 725 Controller with the HySecurity installer app. HySecurity Gate PIN only appears when BLE Enable is set to 1 (ON).
BLUEBUS OPTIONS MENU		BlueBUS submenu
NONE, BLUEBUS DEVICES		Lists the configurations of the connected BlueBUS devices.
SCAN FOR DEVICES	<b>0 = OFF</b> 1 = ON	Change to 1 (ON) to scan for BlueBUS devices. Use this function to install and uninstall BlueBUS device for the firmware to recognize and monitor as an external entrapment sensor(s).
SYSTEM ADDRESS	<b>0 (OFF)</b> - 99 (DEBUG OUT)	Set system address for network communication: 0-9 = set individual polling addresses. 10-19 = for Modbus communication. 20 - 99 sets individual polling addresses.
OXI MENU		OXI Submenu, only appears when an OXI MegaCode receiver is connected to the SmartTouch 725 Controller.
OXI ENABLE	<b>0 = OFF</b> 1 = ON	Enables or disables the NICE OXI MegaCode receiver. The rest of the menus only appear when OXI Enable is set to 1 (ON).
KEY FOB PAIRING	<b>1 = REMOTE OPEN</b> 2 = OPEN 3 = CLOSE 4 = STOP 5 = PARTIAL OPEN 6 = RELAY 47 7 = RELAY 48 60SEC	Set the function to assign to a fob/button and then press the fob button to pair it to the SmartTouch 725 Controller. Write down the address of each learned key fob and who it is given to for tracking purposes or removal later.
KEY FOB REMOVAL	<b>0 = NO</b> 1 = YES	Set to YES and activate a fob button to remove it from the SmartTouch 725 controller.
KEY FOB LIST	<b>0 = NO</b> 1 = YES	Set to YES to use the arrow buttons to scroll through the list of paired fobs. While scrolling through the programmed fobs, pressing SELECT on the displayed key fob button will give the option to delete the individual fob.
REMOVE ALL KEYS	<b>1 = NO</b> 1 = YES	Set to YES to remove all paired fobs from the SmartTouch 725 Controller.

# Connect to the HySecurity Installer App

## SET BLUETOOTH SWITCH:

1. Set the AC and DC switches to OFF.
2. Remove the rubber plug or OXI receiver from receiver slot (Figure 67).
3. Move the switch to the ON position (Figure 68).
4. Place the rubber plug in the OXI receiver slot.

## ENABLE BLUETOOTH IN THE MENUS:

5. Set the AC and DC Switches to ON.
6. Press MENU on the SmartTouch 725 Controller.
7. Press the UP or DOWN arrow to navigate to EXTERNAL COMMUNICATIONS and press SELECT.
8. Press the UP or DOWN arrow to navigate to BLUETOOTH OPTIONS MENU and press SELECT.
9. Press the UP or DOWN arrow to select 1 (ON) and press SELECT.
10. Press the UP or DOWN arrow to show BLE PIN and GATE NAME. Record the PIN and GATE NAME.

## CONNECT THE APP AND CONTROLLER:

11. Open the HySecurity Installer App. Always keep the app up-to-date.
12. Tap Connect.
13. Tap the name of the appropriate operator.
14. Enter the PIN from step 10.
15. Connect button changes color to green to indicate good connection.

Note: For improved security, BLE is automatically disabled at midnight. Follow above steps to re-enable as needed.

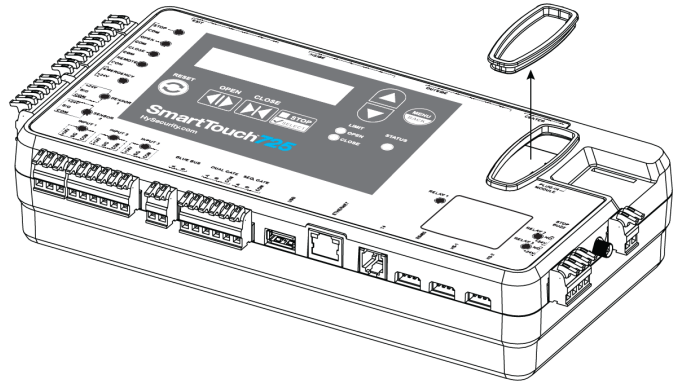

Figure 67. Remove OXI Receiver Cover



Figure 68. Bluetooth Switch



Figure 69. Bluetooth Enabled Display

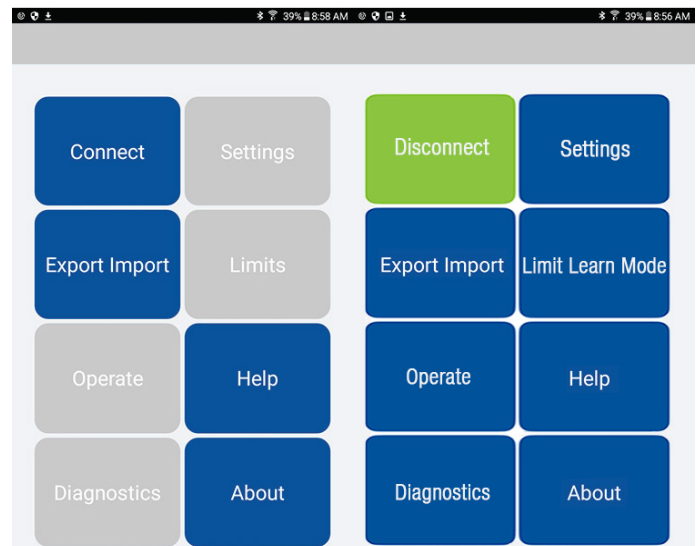

Figure 70. HySecurity Installer App Connect and Disconnect

# OXI MegaCode Receiver and Programming

Note: The button on the OXI MegaCode receiver is not needed for programming fobs with the SmartTouch 725 and should not be pressed during the following installation processes.

## Install and enable the receiver:

1. Remove the receiver port rubber plug (Figure 71).
2. Install the receiver (Figure 72).
3. Install a whip or coaxial antenna into the receiver antenna terminal for better range. Mount any external antenna onto the top of a fixed fence post near the operator.
4. Press MENU on the SmartTouch 725 Controller.
5. Press the UP or DOWN arrow to navigate to EXTERNAL COMMUNICATIONS and press SELECT.
6. Press the UP or DOWN arrow to navigate to OXI RADIO MENU OPTIONS and press SELECT.
7. Press the UP or DOWN arrow to navigate to ENABLE and press SELECT.
8. Press the UP or DOWN arrow to select ON and press SELECT.

## Pair a fob:

1. Open OXI RADIO MENU OPTIONS (steps 4 - 6 to install receiver).
2. Press the UP or DOWN arrow to navigate to KEY FOB PAIRING and press SELECT.
3. Press the UP or DOWN arrow to select the function.
4. Press and hold the appropriate button on the fob.
5. Press SELECT. Display will beep and state PAIRED.
6. Repeat steps 2-5 to pair additional fob buttons or fobs.
7. Press MENU until gate status displays.
8. Press the buttons on the fob to test operation.

## Remove a single fob in hand:

1. Open OXI RADIO MENU OPTIONS (steps 4 - 6 to install receiver).
2. Press the UP or DOWN arrow to navigate to KEY FOB REMOVAL and press SELECT.

3. Press the UP or DOWN arrow to select 1 (ON).
4. Press and hold the button on the fob and press SELECT to remove.
5. Repeat steps 3 and 4 for every fob button to be removed.

## Remove a single fob from a list:

Note: It is important to keep a log of fobs and who is responsible for each for this method.

1. Open OXI RADIO MENU OPTIONS (steps 4 - 6 to install receiver).
2. Press the UP or DOWN arrow to navigate to KEY FOB LIST and press SELECT.
3. Press the Up or DOWN arrow to navigate to the fob number in the list and press SELECT.
4. Press the Up or DOWN arrow to select Y and press SELECT. This removes the fob.

## Remove all fobs:

1. Open OXI RADIO MENU OPTIONS (steps 4 - 6 to install receiver).
2. Press the UP or DOWN arrow to navigate to REMOVE ALL KEYS and press SELECT.
3. Change the setting to 1 (YES) and press SELECT.

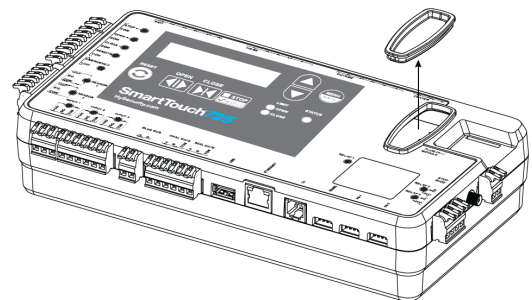

Figure 71. Remove OXI Port Rubber Plug

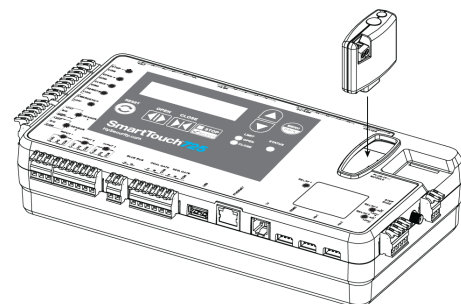
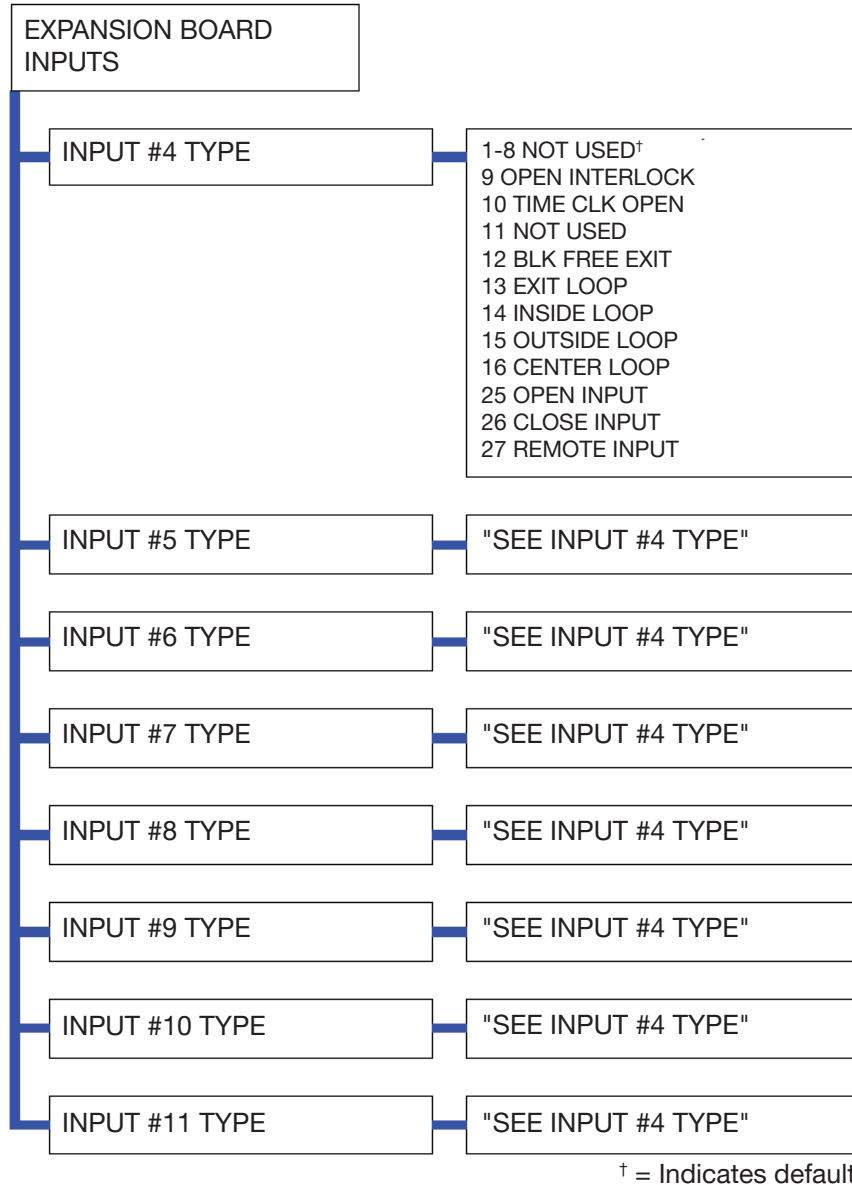

Figure 72. Install OXI Receiver

# Expansion Board Inputs



**Table 22. SmartTouch 725 Expansion Board Inputs Settings**

MENU DISPLAY	SETTINGS	DESCRIPTION
INPUT #4-11 TYPE	1 = NOT USED 2-7 = NOT USED 8 = PARTIAL OPEN (SLIDE ONLY) 9 = OPEN INTERLOCK 10 = TIME CLK OPEN 11 = NOT USED 12 = BLK FREE EXIT 13 = EXIT LOOP 14 = INSIDE LOOP 15 = OUTSIDE LOOP 16 = CENTER LOOP 25 = OPEN INPUT 26 = CLOSE INPUT 27 = REMOTE INPUT	See Programmable Inputs section for more information.

Note: For expansion board relays see "User Relay Outputs" on page 64.

# I/O Expansion Module Mounting and Wiring

1. Install the mounting plate to the operator to the right of the controller mounting plate. Make sure that the three screws marked (1) are in position and snug.
2. Connect the I/O expansion module (HS-A) to the SmartTouch 725 Controller (HS-2) with the communication cable (MX4330).
3. Optional step: To use any of the R6 - R11 +24V ports connect power from the drive module. Connect power between I/O Expansion and Drive Modules. EXT +24 to +; EXT COM to -.

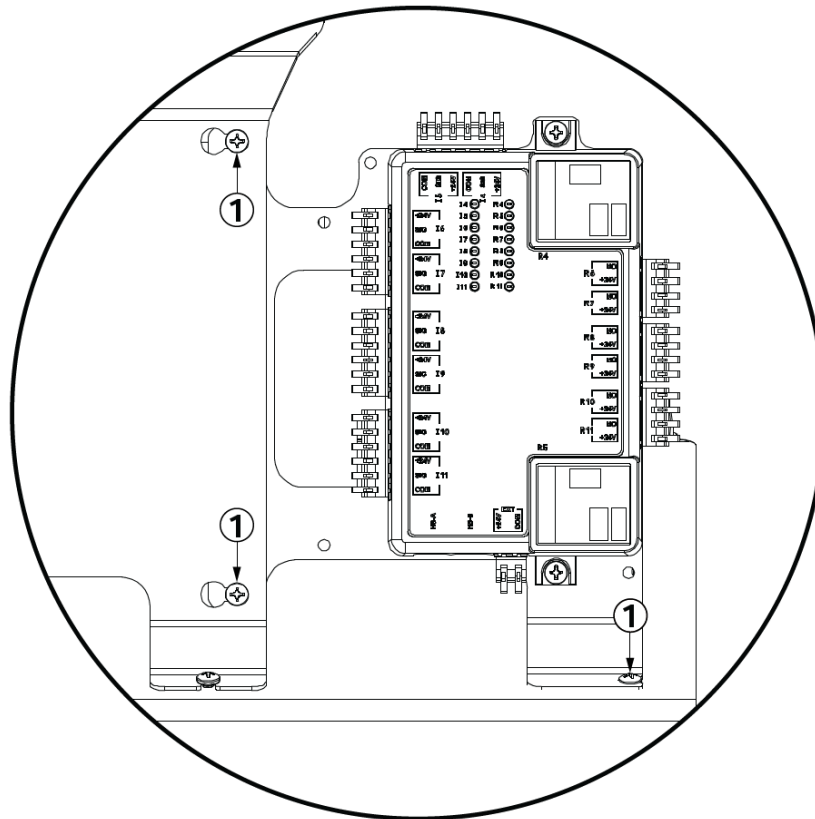

Figure 73. Install the I/O Expansion Module and Mounting Plate

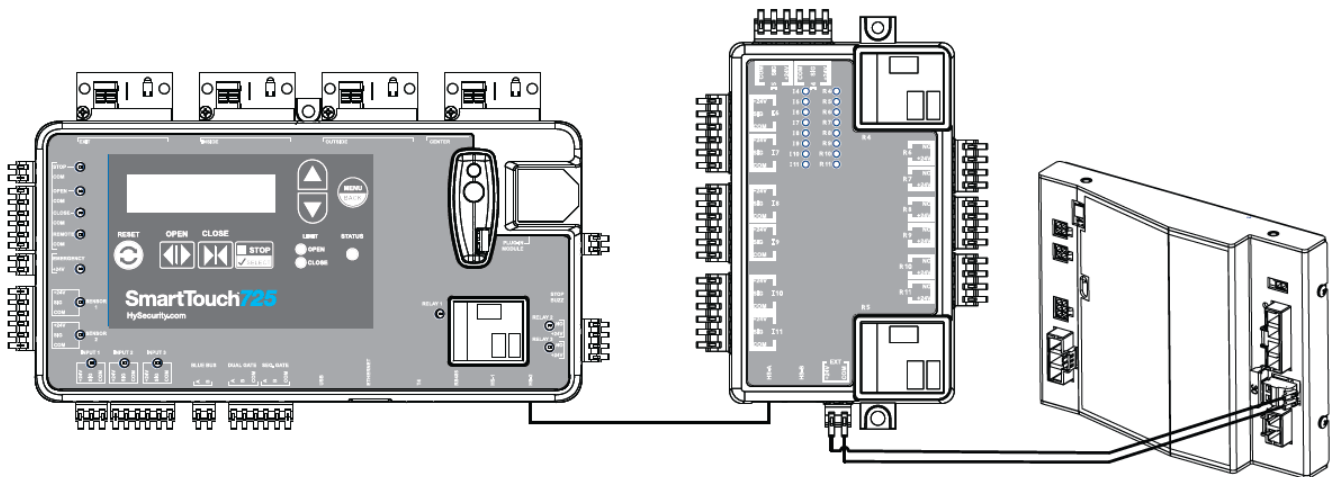
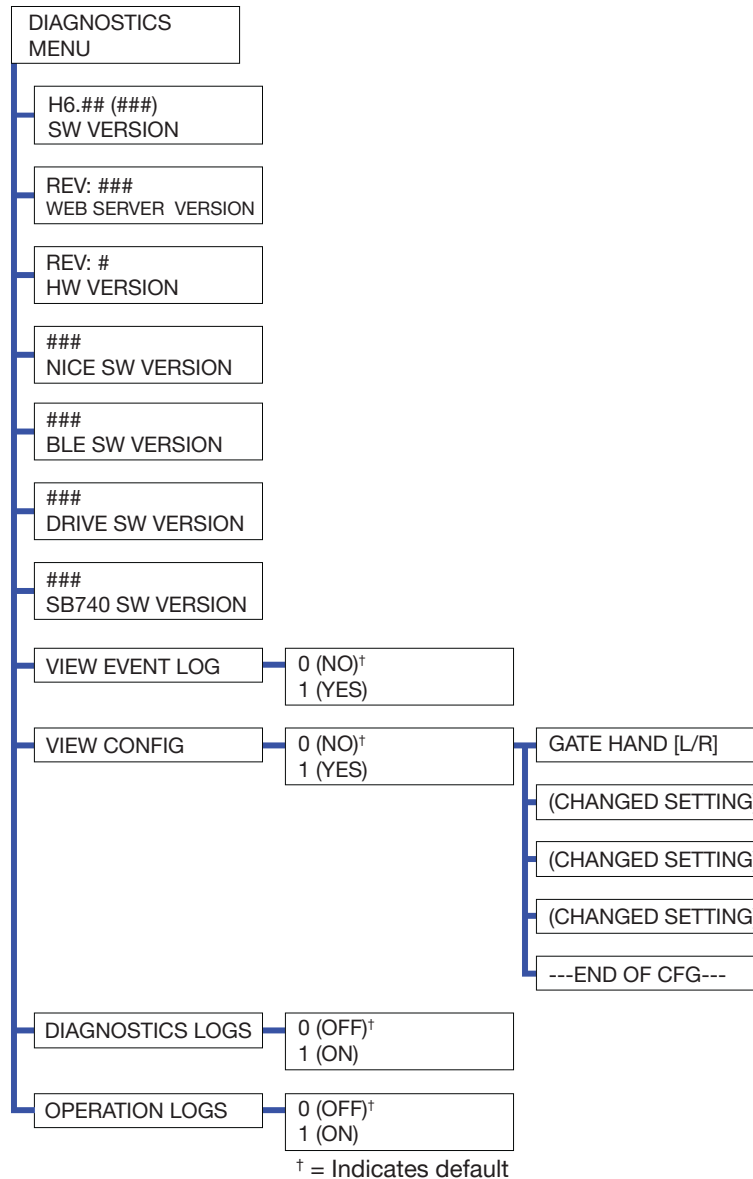

Figure 74. Connect the SmartTouch 725 Controller (HS-2) to the I/O Expansion Module (HS-A). Connect 24V from the Drive Module to the I/O Expansion Module for 24V.

# Diagnostics Menu



**Table 23. SmartTouch 725 Diagnostics Menu Settings**

MENU DISPLAY	SETTINGS	DESCRIPTION
VIEW EVENT LOG	<b>0 = NO</b> 1 = YES	View a list of events in the SmartTouch 725 Controller's memory.
VIEW CONFIG	<b>0 = NO</b> 1 = YES	View a list of configuration settings for the operator that are different from the defaults (e.g. gate handing and input settings).
DIAGNOSTICS LOGS	<b>0 = OFF</b> 1 = ON	Set to ON to turn on diagnostic logging which logs every aspect of gate operation. Diagnostic logging bogs down the processor and slows response to operate command. Only use when absolutely needed to capture an intermittent issue.
OPERATION LOGS	<b>0 = OFF</b> 1 = ON	Set to ON to log every open, close, or stop command source to track down any intermittent gate operation.

Open the Diagnostics Menu to cycle through a status display of the firmware versions of the different processors (725 Controller, Nice, BLE, Drive module, I/O Expansion Module).

# 24/7 Clock and Timer

24/7 CLOCK AND TIMER	
SET CLOCK	MM/DD/YY HH:MM
SET TIME ZONE	-12:00 ... -10:00 Hawaii ... -08:00 PST <sup>†</sup> -07:00 MST -06:00 CST -05:00 EST ... 00:00 LONDON (+0 UTC) ... ... +12:00
ENABLE DST	0 (OFF) <sup>†</sup> 1 (ON)
ENABLE OPEN TMR	0 (OFF) <sup>†</sup> 1 (ON)
CLEAR SCHEDULE	0 (NO) <sup>†</sup> 1 (YES)
SET OPEN DAY 0-10	0 UNUSED <sup>†</sup> 1 EVERYDAY 2 WEEKDAYS 3 WEEKEND 4 SUNDAY 5 MONDAY 6 TUESDAY 7 WEDNESDAY 8 THURSDAY 9 FRIDAY 10 SATURDAY
SET OPEN TIME 1--8	HH:MM ^
SET OPEN LEN 1--8	HH:MM ^

<sup>†</sup> = Indicates default

# 24/7 CLOCK

**Table 24. SmartTouch 725 24/7 Clock and Timer Settings**

MENU DISPLAY	SETTINGS	DESCRIPTION
SET CLOCK	MM/DD/YY HH:MM ^	Set the date and time. Date and time must be set before open timers can be used.
SET TIME ZONE	-12:00 ... -10:00 Hawaii ... <b>-08:00 PST<sup>†</sup></b> -07:00 MST -06:00 CST -05:00 EST ... 00:00 LONDON (+0 UTC) ... ... +12:00	Set time zone based on standard UTC/GMT. Do not set based on DST.
ENABLE DST	<b>0 = OFF</b> 1 = ON	Enable DST (Daylight Savings Time)
ENABLE OPEN TIMER	<b>0 = OFF</b> 1 = ON	Enable or disable the open timer. When enabled, any open timer that is programmed will hold the gate open at the programmed time for the programmed duration. Additionally, any relay set to option 46 will be activated regardless of the enable open timer setting.
CLEAR SCHEDULE	<b>0 = NO</b> 1 = YES	Clear all programmed open timer settings.
SET OPEN DAY 0-10	<b>0 = UNUSED</b> 1 = EVERYDAY 2 = WEEKDAYS 3 = WEEKEND 4 = SUNDAY 5 = MONDAY 6 = TUESDAY 7 = WEDNESDAY 8 = THURSDAY 9 = FRIDAY 10 = SATURDAY	Assign day setting to open timer setting 0-10.
SET OPEN TIME 1-8	HH:MM ^	Set the time when the programmed open timer (1-8) turns on the programmed relay or opens the gate.
SET OPEN LENGTH 1-8	HH:MM ^	Set the duration of time that the programmed open timer (1-8) holds the gate open.

# Maintenance

## MECHANICAL MAINTENANCE

The SwingSmart 535 requires minimal mechanical maintenance. Check the following on a routine basis:

- Sweep debris out and away from the chassis.
- Check for signs of rust. If any areas of rust are found, reduce spread of corrosion by treating areas with a rust inhibitor.
- Check for wear on tamper clamp. Verify limits are set correctly per instructions on page 25 to avoid collision with physical stops which causes unnecessary taper clamp slip. Replace if required.
- Verify condition of swing arm elbow joint.
- Check for damage due to gate strikes. Replace bushings if required. Check the gearbox for leaks.
- Grease swivel joint at gate attachment point.
- Replace worn out batteries. Refer to "DC Battery Replacement" on this page.

## FUSE REPLACEMENT

A 30A fuse is located next to the battery harness. It requires no maintenance, but if blown due to a power surge, swap it out with a new fuse (Figure 75). ALERT 28 BATT DISCONNECTED indicates a blown fuse or disconnected battery.

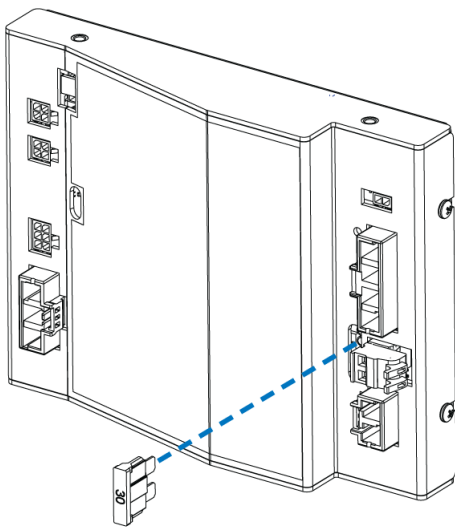

Figure 75. Fuse Replacement

## DC BATTERY REPLACEMENT

Nice provides a one year warranty from the date of shipment for all batteries supplied with the SwingSmart 535 operator.

Display indicators of a low battery include:

- LOW BATTERY or DEAD BATTERY
- ALERT 18 - CHANGE BATTERY
- ALERT 28 - DISCONNECTED BATTERIES. Gate operation is affected by AC power loss.

The two 8Ah batteries are located on the left hand side of the power shelf behind power shelf cover.

**To replace the batteries:**

1. Remove the front cover.
2. Set the AC and DC power switches to OFF.
3. Remove the power shelf cover.
4. Cut the zip ties on the batteries.
5. Disconnect the blue jumper wire, disconnect the wire harness, and remove the 8Ah batteries.

Note: Dispose of batteries properly.

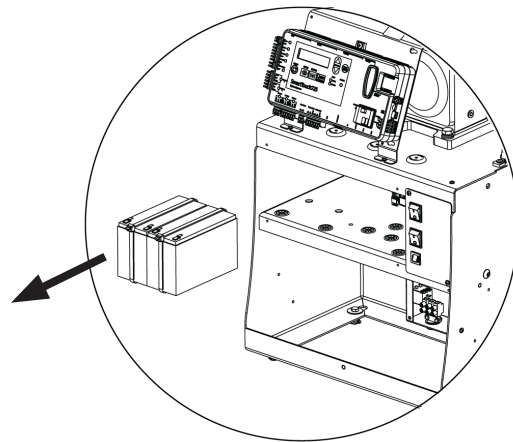

Figure 76. Remove the Batteries

6. Install the new batteries.
7. Connect the red harness wire to the red terminal on left battery.
8. Connect the blue harness wire to the black terminal on the right battery.
9. Connect the blue jumper wire between the batteries.
10. Set the AC and DC switches to ON and replace the front cover.

# Additional Safety Information

## ELECTRICAL SAFETY

- Turn gate operator and all circuit breakers OFF before performing maintenance on the gate operator or making contact with output receptacles.
- Never insert any objects into output receptacles during operation. The possibility exists of electrical shock, electrocution, or death.
- Never let power wires lay in water.
- Never use damaged or worn wire when connecting equipment. Inspect for cuts in the insulation.
- Never grab or touch a live power cord or cable with wet hands. The possibility exists of electrical shock, electrocution, or death.
- Always make certain that proper power has been selected for the job. See Cable Selection Chart in this manual.



## GROUNDING SAFETY

- Always make sure that electrical circuits are properly grounded to a suitable earth ground (ground rod) per the National Electrical Code (NEC) and local codes. Severe injury or death by electrocution can result from operating an unground operator.
- Never use gas piping as an electrical ground.



## BATTERY SAFETY

HySecurity 535 operators use sealed Absorbed Glass Mat (AGM) batteries and HySecurity highly recommends replacing used batteries with new AGM-type batteries.

### CAUTION

Batteries used with HySecurity gate operators contain materials considered hazardous to the environment. Proper battery disposal is required by federal law. Refer to Hazardous Waste Regulations federal guidelines.

### To reduce risk of fire or injury to persons:

- Observe polarity between batteries and charging circuit.
- Never mix battery sizes, types, or brands. Charging circuit on HySecurity DC operators is designed for AGM-type batteries, not flooded lead acid-type batteries.
- Exercise care in handling batteries. Be aware metal found in rings, bracelets, and keys can conduct electricity, short batteries, and cause potential injury.
- Do not open or mutilate batteries. Battery cells contain corrosive materials which may cause burns and other injuries. Material within batteries is toxic.
- Always dispose of batteries properly. Do not place batteries in fire. Battery cells may explode. Follow federal guidelines for proper disposal of hazardous waste.
- Always keep battery cables in good working condition. Repair or replace all worn cables.
- Replace batteries according to instructions found in DC Battery Replacement.
- Do not charge a frozen battery. Battery can explode. If frozen, warm the battery to at least 61°F (16°C).

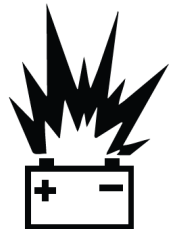

# Additional Safety Information

## ENVIRONMENTAL SAFETY/ HAZARDOUS MATERIALS AND PROPER DISPOSAL

Decommissioning is a controlled process used to safely retire a piece of equipment that is no longer serviceable. If the equipment poses an unacceptable and unreparable safety risk due to wear or damage or is no longer cost effective to maintain (beyond life-cycle reliability) and is to be decommissioned (demolition and dismantlement), be sure to follow rules below.



- Do not pour waste or oil directly onto the ground, down a drain or into any water source.
- Contact your country's Department of Public Works or recycling agency in your area and arrange for proper disposal of any electrical components, waste or oil associated with this equipment.
- When the life cycle of this equipment is over, remove battery and bring to appropriate facility for lead reclamation. Use safety precautions when handling batteries that contain sulfuric acid.
- When the life cycle of this equipment is over, it is recommended that the frame and all other metal and plastic parts be sent to a recycling center.

Metal and plastic recycling involves the collection of metal and plastic from discarded products and its transformation into raw materials to use in manufacturing a new product.

Recyclers and manufacturers alike promote the process of recycling metal and plastic. Using a metal and plastic recycling center promotes energy cost savings.

# Troubleshooting/Alerts/Faults/Errors

**Table 25. SmartTouch 725 Controller - Troubleshooting**

Display Condition	Description Alert, Error or Fault	Possible Causes	Solutions
SAFE MODE	Safe Mode Alert	Occurs when an edge sensor or Inherent Entrapment Sensor (IES) trips. Gate binding, wind, or a faulty edge sensor can cause a false alert. All inputs are still functional during safe mode, but Close Timer is disabled until an operate command is received.	<ol style="list-style-type: none"> <li>1. Activate any operate command.</li> <li>2. Remove obstruction.</li> <li>3. Correct gate hardware.</li> <li>4. Correct faulty edge sensor.</li> <li>5. Adjust IES sensitivity.</li> </ol>
ENTRAPMENT MODE	Entrapment Mode Alert	<p>Occurs when IES is tripped when gate is already in Safe Mode (two IES trips in one cycle). Operator will not function until it is reset, which can occur by:</p> <ul style="list-style-type: none"> <li>• An Open or Stop command from a push-button control</li> <li>• Pressing STOP button on operator side</li> <li>• Pressing RESET button below display</li> </ul> <p>Gate binding, wind, or a faulty edge sensor can cause a false alert. Emergency Close or Fire Open input activation will also stop the gate in Entrapment Mode.</p>	Refer to solutions above.
NO AC POWER	No AC Input Power Advisory only	AC power is shut off at source (breaker) or is not connected. AC power switch on operator (lower rocker switch) is turned off, or circuit breaker on the operator has tripped. Failed power supply. Power supply selector switch is in the wrong position. May appear on a solar powered operator when there is not enough power output from the panel.	<ol style="list-style-type: none"> <li>1. Verify Voltage Selector switch is set for the supplied voltage.</li> <li>2. Set AC switch to On.</li> <li>3. Reset operator circuit breaker or reset circuit breaker at electrical panel.</li> <li>4. Verify AC power to operator. Have a licensed electrician check wiring.</li> <li>5. Check power supply output is 36VDC.</li> </ol>
LOADING FW	Firmware is being loaded into SmartTouch 725 Controller.	SmartTouch 725 is currently being updated. Display will show which specific processor firmware is loading.	Wait for firmware to finish loading.

Note: Troubleshooting table continues on next page.

# Troubleshooting/Alerts/Faults/Errors

**Table 25. SmartTouch 725 Controller - Troubleshooting**

Display Condition	Description Alert, Error or Fault	Possible Causes	Solutions
LOW 24VDC	Low 24VDC UPS Batteries Advisory only	Occurs when battery voltage has dropped to less than 22V. At this level, batteries have about 20% charge. Normal function until 21V. <ul style="list-style-type: none"> <li>• No AC Power.</li> <li>• Wiring / Connector problem</li> <li>• Drive module charger failure</li> <li>• Power supply failure</li> </ul>	<ol style="list-style-type: none"> <li>1. Verify AC power.</li> <li>2. Check all connections. Clean or repair as required.</li> <li>3. Check battery condition and replace as required.</li> <li>4. Check charger voltage is 27VDC at red/blue battery wires. Replace drive controller.</li> <li>5. Verify power supply voltage of 36VDC and replace as required.</li> </ol>
DEAD BATTERY	Extremely low UPS batteries – no automatic operation - batteries below 21V	Occurs when battery voltage has dropped to less than 21V. At this level, batteries have about 10% charge. Gate will automatically open or close depending upon setting chosen. No additional automatic function is possible, but limited push button control is available down to 18V.	Refer to solutions above.
HYSECURITY BAD POWER	Critically low 24V supply power. This message can occur only on initial start up if power is critically low.	DC power is below 14V – no control functions will be allowed at all.	Refer to solutions above.
No display, LED blinking	SmartTouch 725 Controller is receiving power, but battery voltage is very low.	Several possible causes: <ul style="list-style-type: none"> <li>• AC power has been shut off from the operator for too long and the batteries are drained.</li> <li>• Wiring problem.</li> <li>• Operator may be in standby mode.</li> <li>• Batteries no longer hold a charge.</li> <li>• Failed SmartTouch 725 Controller.</li> <li>• Failed power supply or drive module.</li> <li>• Disconnected com (HSP) wire between SmartTouch 725 Controller and drive module.</li> </ul>	Refer to solutions above.

# Troubleshooting/Alerts/Faults/Errors

**Table 26. SmartTouch 725 Controller - Alerts**

Display Condition	Description Alert, Error or Fault	Possible Causes	Solutions
ALERT 1 FORCE OPEN	Gate forced open. Alarm will sound.	Gate has been forced off the full close limit and is being prevented from re-closing.	Will self-clear after an open or close input.
ALERT 2 DRIFT CLOSED	Gate drifted closed.	Gate has drifted off the full open limit and is being prevented from re-opening.	Will self-clear after an open or close input.
ALERT 3 EXCESS DRIFT	Gate drift in transit - Advisory only	Alert appears if gate drifts three times in a five minute period.	Check track to make sure it is level.
ALERT 4 THERMAL OVERLOAD	Thermal overload alert. When alert is triggered, gate can only “fully open” until alert is cleared.	Motor drive heat sink exceeds 195°F. Alert temporarily disables operator, but automatically resets itself when it cools down. May also occur if the heatsink temperature is 70°F higher than ambient temperature.	Check gate hardware. Alert automatically clears when temperature drops below threshold.
ALERT 5 BOTH LIM ACTIVE	Both limit sensors are on at the same time.	<ul style="list-style-type: none"> <li>Short in wiring or drive module connection.</li> <li>Failed limit sensor.</li> <li>Limit sensors unplugged from drive board.</li> </ul>	<ul style="list-style-type: none"> <li>Repair any wiring issues.</li> <li>Check limit sensors and replace as required.</li> </ul>
ALERT 6 LIM NOT RELEASED (Swing only)	The limit did not release when the operator was commanded to move.	<ul style="list-style-type: none"> <li>Loose taper clamp.</li> <li>Arm assembly binding.</li> <li>Failed limit switch.</li> </ul>	<ul style="list-style-type: none"> <li>Tighten taper clamp.</li> <li>Check limit sensors and replace as required.</li> <li>Verify arm condition.</li> </ul>
ALERT 7 FREQ SHIFT FAULT*	Hy5B detects a frequency change outside normal range.	Likely causes are poor integrity of loops or metallic objects within range.	Check lead and roadway loop wires for problems. Replace if necessary.
ALERT 8 LOOP SHORTED*	Hy5B detects a loop shorted to ground.	Caused by inadequate insulation of loop wires.	Refer to solution above.
ALERT 9 LOOP OPEN*	Hy5B detects a lack of continuity in loop wire.	Caused by broken loop wire or wire has come unplugged from detector.	Refer to solution above.
ALERT 10 I2C BUS ERROR*	Communication error detected to a Hy5B vehicle detector.	Caused by removal of Hy5B or lack of integrity of socket connection.	Remove and re-install the Hy5B and press RESET. Replace Hy5B, if necessary.
ALERT 11 DETECTOR FAULT*	A problem detected within a Hy5B vehicle detector.	Caused by a fault within Hy5B.	Refer to solution above.
ALERT 12 ON TOO LONG*	An input loop (Hy5B or box detector output) is active for more than 5 minutes.	Caused when SmartTouch 725 Controller sees an active loop for more than 5 minutes. “Active” loop can be actual or false.	Check traffic patterns at site. Loop and lead in wires should be checked for problems or replaced.

Note: Alerts table continues on next page.

\* This message will also indicate which detector the alert applies to: Exit Loop (ELD), Inside Obstruction Loop (IOLD), Outside Obstruction Loop (OOLD), or Center Loop (CLD).

# Troubleshooting/Alerts/Faults/Errors

**Table 26. SmartTouch 725 Controller - Alerts**

Display Condition	Description Alert, Error or Fault	Possible Causes	Solutions
ALERT 13 STIFF GATE	A gate takes more power to move over time.	Caused by degrading gate hardware or debris in track. This alert appears in history log. It does not have any effect with regard to opening or closing gate.	Check and correct gate hardware as required.
ALERT 14 STUCK GATE	The gate cannot move at all.	Caused by broken gate hardware or ice/snow buildup.	Check and correct gate hardware as required. Clear ice and snow.
ALERT 15 MISSED LIMIT (Slide only)	Limit magnet is missing or is not detected.	<ul style="list-style-type: none"> <li>Limit magnet fell off or limit sensor wires are damaged.</li> <li>Limit magnet not installed in correct location.</li> </ul>	<ol style="list-style-type: none"> <li>Make sure limit magnet is properly fastened.</li> <li>Check limit sensor to make sure it is reading magnet.</li> <li>Change sensor if it or its wires are damaged.</li> </ol>
ALERT 18 CHANGE BATTERY	24VDC UPS batteries need to be replaced. Buzzer will chirp every minute until UPS batteries are replaced.	Batteries are not taking a charge properly.	Replace the 24VDC UPS batteries.
ALERT 22 INTLOCK FAILURE	Interlock/Sequential Gate communication lost. Alert auto clears when communication between two operators is restored.	<ul style="list-style-type: none"> <li>Appears when communication connection is lost for more than 5 seconds between interlocked or sequenced gate operators.</li> <li>Solo operator has Sequential gate set to ON.</li> </ul>	<ol style="list-style-type: none"> <li>Check cable connections and wiring. Make sure both operators are working properly with same, current software versions.</li> <li>Verify Dual Gate and Sequential Gate are both set to (0) on a solo operator.</li> </ol>
ALERT 28 BATTERY DISCONNECTED	Battery disconnected from drive module.	Dead or disconnected batteries detected by SmartTouch 725 Controller. Operator may still function on AC power but will not have battery backup. Battery fuse may be blown.	Replace or reconnect batteries. Replace fuse if needed.
ALERT 29 MOTOR CUR TRAP	Drive board stopped motor due to large current spike.	<ul style="list-style-type: none"> <li>Gate hit an object or hardware is degrading causing it to be difficult to move.</li> <li>Gearbox issue.</li> </ul>	<ol style="list-style-type: none"> <li>Drop the chain to verify gate can be moved by hand.</li> <li>Run the operator with the chain disengaged and verify it runs and sounds normal.</li> <li>Reconnect the chain and cycle the gate.</li> </ol>

\* This message will also indicate which detector the alert applies to: Exit Loop (ELD), Inside Obstruction Loop (IOLD), Outside Obstruction Loop (OOLD), or Center Loop (CLD).

# Troubleshooting/Alerts/Faults/Errors

**Table 27. SmartTouch 725 Controller - Faults**

Display Condition	Description Alert, Error or Fault	Possible Causes	Solutions
FAULT 1 MOTOR RUN TIME (SWING ONLY)	The motor is on longer than the maximum run time selected.	<ul style="list-style-type: none"> <li>• Taper clamp slipping</li> <li>• Missing target or failed limit sensor</li> </ul>	<ol style="list-style-type: none"> <li>1. Tighten taper clamp.</li> <li>2. Check limit sensors. Replace as required.</li> <li>3. Increase Max Run Timer.</li> </ol>
FAULT 2 BLUEBUS P#	Learned BlueBus sensor is missing or not working.	<p>This fault can only occur if BlueBus sensor check fails.</p> <p>Display will show BlueBus device that is missing.</p>	<ol style="list-style-type: none"> <li>1. Check learned BlueBus sensors are connected.</li> <li>2. Correct malfunctioning sensor.</li> </ol>
FAULT 4 GATE NO LOAD	SmartTouch 725 Controller detects no load on operator. Gate is non-operational while this fault is triggered.	<ul style="list-style-type: none"> <li>• Motor wires disconnected.</li> <li>• DC switch off.</li> <li>• Drive board may have failed.</li> <li>• Motor may be damaged or faulty.</li> </ul>	<ol style="list-style-type: none"> <li>1. Check DC motor wires condition and connection to drive module.</li> <li>2. Turn DC power switch on.</li> <li>3. Tighten taper clamp.</li> <li>4. Press RESET to clear fault.</li> </ol>
FAULT 14 STUCK GATE	SmartTouch 725 Controller could not overcome stuck gate after 3 attempts. Gate is non-operational while this fault is triggered.	Caused by broken gate hardware or ice/snow buildup. No movement was detected by motor encoder.	<ol style="list-style-type: none"> <li>1. Check and correct gate hardware as required.</li> <li>2. Press RESET to clear fault.</li> <li>3. Make sure that motor wires are connected.</li> </ol>

# Troubleshooting/Alerts/Faults/Errors

**Table 28. SmartTouch 725 Controller - Errors**

Display Condition	Description Alert, Error or Fault	Possible Causes	Solutions
ERROR 1 DIRECTION ERROR	SmartTouch 725 Controller detects operator ran in wrong direction.	Limit sensor plugs switched on drive module.	<ol style="list-style-type: none"> <li>1. Switch limit sensor plugs or reset operator handing Left Hand/ Right Hand.</li> <li>2. Press RESET to clear fault.</li> </ol>
ERROR 3 Hy5B FAILED*	SmartTouch 725 Controller detects communication error with a Hy5B vehicle detector.	Caused by Hy5B removal or socket connection integrity.	<ol style="list-style-type: none"> <li>1. Press RESET.</li> <li>2. Remove and re-install Hy5B.</li> <li>3. Replace Hy5B, if needed.</li> </ol>
ERROR 4 Dual Gate COMM	SmartTouch 725 Controller detects a communication error between primary and secondary in a dual gate installation.	<p>Several possible causes:</p> <ul style="list-style-type: none"> <li>• Primary/Secondary communication cable is installed incorrectly.</li> <li>• Primary/Secondary not configured properly through Installer Menu.</li> <li>• Operator is not properly earth grounded.</li> <li>• Primary/Secondary communication cable installed in same conduit as high-voltage AC power.</li> <li>• One operator is powered off.</li> <li>• Different software versions between operators. Check software version currently loaded in operator by pressing RESET.</li> </ul>	<ol style="list-style-type: none"> <li>1. Correct communication cable.</li> <li>2. Verify one operator is set as Primary and the other is set as Secondary.</li> <li>3. Install ground rod per NEC/NFPA standard.</li> <li>4. Install communication cables in a low voltage conduit.</li> <li>5. Ensure AC power is present at both operators and all power switches are On.</li> <li>6. Make sure both operators are running same software version.</li> </ol>
ERROR 5 No display	Display is blank, but the error appears in the log and means that SmartTouch 725 Controller detects a serious internal error.	Internal software/hardware error. Report any instance of this error to HySecurity Technical Support.	<ol style="list-style-type: none"> <li>1. Set AC &amp; DC switches to OFF and then to ON.</li> <li>2. Update to latest firmware version.</li> <li>3. Replace SmartTouch 725 Controller.</li> </ol>

Note: Errors table continues on next page.

\* This message will also indicate which detector the alert applies to: Exit Loop (ELD), Inside Obstruction Loop (IOLD), Outside Obstruction Loop (OOLD), or Center Loop (CLD).

# Troubleshooting/Alerts/Faults/Errors

**Table 28. SmartTouch 725 Controller - Errors**

Display Condition	Description Alert, Error or Fault	Possible Causes	Solutions
ERROR 6 DRIVE BOARD COMM	Indicates communication failure between drive module and SmartTouch 725 Controller.	Drive module communication failed or the drive module may have failed.	<ol style="list-style-type: none"> <li>1. Update controller firmware to latest version.</li> <li>2. Verify connection between SmartTouch 725 Controller and drive module (HSP1).</li> <li>3. Replace drive module.</li> </ol>
ERROR 7 MENU CHECKSUM	Firmware issue exists that may require factory reset.	Corrupt firmware or data.	Call Nice Technical Support for assistance.
ERROR 8 RPM SENSOR	RPM sensor disconnected.	Motor Encoder wires are damaged or unplugged.	Check wiring from motor to drive module.
ERROR 9 BATTERY DISCONNECT	SmartTouch 725 Controller detects no battery connected.	<p>Batteries are disconnected, or a wiring fault exists.</p> <p>Only appears when the batteries are disconnected and the only input power is solar panels.</p>	<ol style="list-style-type: none"> <li>1. Connect battery harness to drive module.</li> <li>2. Correct any issues with battery wiring.</li> <li>3. Check fuse on drive module.</li> </ol>

**Table 29. BLDC Drive Board Status LEDs**

Status LED 1	Status LED 2	Status LED 3	Status LED 4	Description	Operator Fault
ON	ON	ON	BLINK	All Systems Normal	None
ON	OFF	ON	BLINK	Motor Drive Communication Fault	Error-6: Drive board firmware or hardware fault. Call Tech Support.
ON	ON	OFF	BLINK	No Communication with SmartTouch 725 board	Error-6: Communication issue with drive board. Check cable connections between boards.
OFF	OFF	OFF	OFF	Main Microprocessor Not Running	Error-6: No power input. Internal Fault. Call Tech Support.
All other combinations: reserved for future use.				Not Implemented	Unknown Fault

## Appendix - French Translations

English	French
<p><b>IMPORTANT SAFETY INSTRUCTIONS</b>  <b>WARNING – To reduce the risk of injury or death:</b></p>	<p><b>INSTRUCTIONS DE SÉCURITÉ IMPORTANTES</b>  <b>AVERTISSEMENT – Pour réduire les risques de blessures et de mort :</b></p>
<p>1. READ AND FOLLOW ALL INSTRUCTIONS.</p>	<p>1. LISEZ CETTE NOTICE ET CONFORMEZ-VOUS AUX MISES EN GARDE</p>
<p>2. Never let children operate or play with gate controls. Keep the remote control away from children.</p>	<p>2. Ne laissez jamais les enfants manoeuvrer les commandes de la barrière ou jouer avec celles-ci. Laissez la télécommande hors de la portée des enfants.</p>
<p>3. Always keep people and objects away from the gate. <b>NO ONE SHOULD CROSS THE PATH OF THE MOVING GATE.</b></p>	<p>3. Tenez toujours à l'écart de la barrière toute personne ou tout objet avoisinant. <b>IL NE FAUT JAMAIS PASSER DANS LA TRAJECTOIRE D'UNE BARRIÈRE EN MOUVEMENT.</b></p>
<p>4. Test the gate operator monthly. The gate <b>MUST</b> reverse on contact with a rigid object or stop when an object activates the non-contact sensors. After adjusting the force or the limit of travel, retest the gate operator. Failure to adjust and retest the gate operator properly can increase the risk of injury or death.</p>	<p>4. Vérifiez le fonctionnement de l'ouvre-barrière une fois par mois. Le sens de la course <b>DOIT</b> s'inverser lorsque la barrière entre en contact avec un objet dur ou la barrière <b>DOIT</b> s'arrêter lorsqu'un objet active les capteurs sans contact. Vérifiez à nouveau l'ouvre-barrière après tout réglage de la force de déclenchement ou du seuil de fin de course. Un réglage incorrect de l'ouvre-barrière ou l'omission de vérifier à nouveau le fonctionnement de l'ouvre-barrière peut causer des blessures, voire la mort.</p>
<p>5. Use the manual release only when the gate is not moving.</p>	<p>5. Utilisez le déverrouillage manuel uniquement lorsque le portail ne bouge pas.</p>
<p>6. <b>KEEP GATES PROPERLY MAINTAINED.</b> Read the user's manual. Have a qualified service person make repairs to gate hardware.</p>	<p>6. <b>ASSUREZ-VOUS QUE LA BARRIÈRE EST CORRECTEMENT ENTRETENUE.</b> Lisez le manuel de l'utilisateur. Confiez la réparation du matériel de la barrière à un technicien qualifié.</p>
<p>7. The entrance is for vehicles only. Pedestrians must use separate entrance.</p>	<p>7. La voie d'accès est réservée aux véhicules seulement. Les piétons doivent utiliser une voie d'accès différente.</p>
<p>8. <b>SAVE THESE INSTRUCTIONS.</b></p>	<p>8. <b>CONSERVEZ CES INSTRUCTIONS.</b></p>

## Appendix - French Translations

English	French
2.3 Install the gate operator only when:	2.3 N'installez l'ouvre-barrière que si:
a. The operator is appropriate for the construction of the gate and the usage Class of the gate,	a. L'ouvre-barrière est approprié pour la structure et la classe d'utilisation de la barrière;
b. All openings of a horizontal slide gate are guarded or screened from the bottom of the gate to a minimum of 1.83 m (6 ft) above the ground to prevent a 57.2 mm (2-1/4 inch) diameter sphere from passing through the openings anywhere in the gate, and in that portion of the adjacent fence that the gate covers in the open position,	b. Toutes les ouvertures de la barrière coulissante sont protégées ou grillagées du bas de la porte jusqu'à un minimum de 1,83 m (6 pi) du sol si bien qu'une sphère de 57,2 mm (2 1/4 po) de diamètre ne peut passer par une ouverture au niveau de la barrière et de la portion de la clôture adjacente que la barrière couvre en position ouverte;
c. All exposed pinch points are eliminated or guarded, and	c. Tous les points de pincement sont éliminés ou protégés;
d. Guarding is supplied for exposed rollers.	d. Des protections sont fournies pour les galets exposés.
2.4 The operator is intended for installation only on gates used for vehicles. Pedestrians must be supplied with a separate access opening. The pedestrian access opening shall be designed to promote pedestrian usage. Locate the gate such that persons will not come in contact with the vehicular gate during the entire path of travel of the vehicular gate.	2.4 L'ouvre-barrière est destiné à n'être installé que sur des barrières utilisées pour les véhicules. Il faut fournir une autre voie d'accès aux piétons. La voie d'accès pour les piétons doit être conçue pour favoriser le passage des piétons. Placez la barrière de sorte que personne ne puisse entrer en contact avec la barrière pour les véhicules sur l'ensemble de sa trajectoire
2.5 The gate must be installed in a location so that enough clearance is supplied between the gate and adjacent structures when opening and closing to reduce the risk of entrapment. Swinging gates shall not open into public access areas.	2.5 Pour réduire les risques de coincement lors de l'ouverture et de la fermeture, la barrière doit être installée dans un endroit où la barrière et les structures avoisinantes sont suffisamment éloignées l'une de l'autre. Les barrières battantes ne doivent pas ouvrir dans une zone d'accès public.
2.6 The gate must be properly installed and work freely in both directions prior to the installation of the gate operator. Do not over-tighten the operator clutch or pressure relief valve to compensate for a damaged gate.	2.6 La barrière doit être bien installée et fonctionner librement dans les deux directions avant d'entreprendre l'installation de l'ouvrebarrière. Ne serrez pas trop l'embrayage ou la soupape de suppression de l'ouvre-barrière pour compenser une barrière endommagée.

## Appendix - French Translations

English	French
<p>2.7 Controls intended for user activation must be located at least 1.83 m (6 ft) away from any moving part of the gate and where the user is prevented from reaching over, under, around or through the gate to operate the controls. Exception: Emergency access controls only accessible by authorized personnel (e.g. fire, police, EMS) may be placed at any location in the line-of-sight of the gate.</p>	<p>2.7 Les commandes destinées à l'activation par l'utilisateur doivent être situées à au moins 1,83 m (6 pi) des pièces mobiles de la barrière et à un endroit où l'utilisateur ne peut pas atteindre les commandes par le dessus, par le dessous, par les côtés et au travers de la barrière. Exception : Les commandes d'accès d'urgence accessibles au personnel autorisé seulement (p. ex. pompier, policier, SMU) peuvent être placées à tout endroit dans le champ de visibilité de la barrière.</p>
<p>2.8 The Stop and/or Reset button must be located in the line of-sight of the gate. Activation of the reset control shall not cause the operator to start.</p>	<p>2.8 Le bouton d'arrêt, le bouton de réenclenchement ou ces deux boutons doivent être situés dans le champ de visibilité de la barrière. L'activation des commandes de réenclenchement ne doit pas mettre en marche l'ouvrebarrière.</p>
<p>2.9 A minimum of two (2) WARNING SIGNS shall be installed, in the area of the gate. Each placard is to be visible by persons located on the side of the gate on which the placard is installed.</p>	<p>2.9 Au moins deux panneaux de mise en garde doivent être installés dans la zone de la barrière. Chaque étiquette doit être visible des personnes situées de chaque côté de la barrière sur laquelle l'étiquette est installée.</p>
<p>2.10 For gate operators utilizing a non-contact sensor:</p>	<p>2.10 Pour les ouvre-barrières qui fonctionnent avec des capteurs:</p>
<p>a. See instructions on the placement of noncontact sensors for each Type of application,</p>	<p>a. Voir les instructions sur le positionnement des capteurs sans contact pour chaque type d'utilisation.</p>
<p>b. Care shall be exercised to reduce the risk of nuisance tripping, such as when a vehicle, trips the sensor while the gate is still moving, and</p>	<p>b. Des précautions doivent être prises pour réduire les risques de déclenchement inutile, comme lorsqu'un véhicule déclenche le capteur alors que la barrière est encore en mouvement.</p>
<p>c. One or more non-contact sensors shall be located where the risk of entrapment or obstruction exists, such as the perimeter reachable by a moving gate or barrier.</p>	<p>c. Un capteur sans contact ou plus doit être situé où il existe un risque de coincement ou d'obstruction, comme dans l'espace que peut occuper la barrière lorsqu'elle est en mouvement.</p>

## Appendix - French Translations

English	French
2.11 For a gate operator utilizing a contact sensor:	2.11 Pour les ouvre-barrières qui fonctionnent avec des capteurs:
a. One or more contact sensors shall be located where the risk of entrapment or obstruction exists, such as at the leading edge, trailing edge, and postmounted both inside and outside of a vehicular horizontal slide gate.	a. Au moins un capteur de contact doit être situé où il existe un risque de coincement ou d'obstruction, comme sur le bord d'ouverture, sur le bord de fermeture et sur les poteaux montés sur l'intérieur ou l'extérieur d'une barrière coulissante pour véhicules.
b. A hardwired contact sensor shall be located and its wiring arranged so that the communication between the sensor and the gate operator is not subjected to mechanical damage.	b. Un capteur de contact doit être installé et câblé de sorte à éviter que la communication entre le capteur et l'ouvrebarrière soit gênée par des dommages mécaniques.
c. A wireless device such as one that transmits radio frequency (RF) signals to the gate operator for entrapment protection functions shall be located where the transmission of the signals are not obstructed or impeded by building structures, natural landscaping or similar obstruction. A wireless device shall function under the intended end-use conditions.	c. Un dispositif sans fil, comme un appareil qui transmet des signaux de radiofréquence (RF) à l'ouvre-barrière pour prévenir le coincement, doit être situé à un endroit où la transmission des signaux ne sera pas obstruée ou gênée par des structures, des arbres ou d'autres obstacles similaires. Un dispositif sans fil doit fonctionner selon les conditions d'utilisation finale prévues.
d. One or more contact sensors shall be located on the inside and outside leading edge of a swing gate. Additionally, if the bottom edge of a swing gate is greater than 152 mm (6 inches) but less than 406 mm (16 inches) above the ground at any point in its arc of travel, one or more contact sensors shall be located on the bottom edge.	d. Au moins un capteur de contact doit être situé sur les bords d'ouverture intérieur et extérieur d'une barrière battante. De plus, si le dessous d'une barrière battante est situé à plus de 152 mm (6 po) mais à moins de 406 mm (16 po) du sol à l'un des points de sa trajectoire, au moins un capteur de contact doit être situé sur le bord inférieur.

# Warranty

1. Warranty. Nice North America LLC ("Nice") warrants that at the time of sale each Nice or HySecurity -branded gate operator ("Product") that it sells will, in all material respects, conform to its then applicable specification and will be free from defects in material and manufacture.

The following additional durational warranties apply to Nice or HySecurity branded Product, depending on whether (1) the Product is purchased through an authorized distributor and (2) whether a timely and complete Product registration is submitted to Nice.

It is therefore important that you register your Product with Nice, online at [www.hysecurity.com/warranty](http://www.hysecurity.com/warranty), within the 60-day period described below.

## 1(a) Nice Products Purchased Through Authorized Distributors and Properly Registered

For any gate operator Product that is purchased from an authorized Nice distributor (this excludes product purchased through internet resellers or any distributor not authorized by Nice), if the Product registration is completed by the Dealer/Installer or End User within 60 days of the date of purchase, the following warranty terms will apply. Nice warrants that the Product will remain serviceable under this warranty for the following periods:

- i) HySecurity brand hydraulic gate operator hydraulics, controls, and mechanical components: Five Years or 500,000 gate cycles (whichever occurs first) after the date of installation;
- ii) HySecurity hydraulic wedge operator hydraulics and controls: Five Years or 500,000 cycles (whichever occurs first) after the date of installation. Wedge mechanical components: Two Years after the date of installation;
- iii) Nice or HySecurity brand commercial grade electromechanical pad-mounted slide and swing operators such as SwingSmart 535 and SlideSmart 535: Five Years or 500,000 cycles (whichever occurs first) after the date of installation, except that commercial grade electromechanical pad-mounted slide and swing operators used for single family residential purposes shall have a warranty term of Seven Years after the date the product was shipped by Nice;
- iv) Nice brand residential grade pad mount swing and slide gate operators such as Juno and Vanguard 3501: Three years after the date of installation,
- v) Nice brand electromechanical linear actuator Swing operators: Three Years after the date of installation;
- vi) HySecurity electromechanical surface mount wedge operator electronics: Two Years or 500,000 gate cycles (whichever occurs first), after the date of installation;
- vii) Electromechanical barrier arm operators: Two years or 1,000,000 gate cycles (whichever occurs first) after the date of installation, provided that the preceding Five Year warranty period in (i), (ii), and (iii) above will not extend beyond seven years from the date that the product was shipped by Nice, and the Two Year warranty period in (ii), (iv), (v), and (vi) above will not extend beyond four years from the date that the product was shipped by Nice.

The preceding warranty durations do not apply to the products or components described below (viii-xi), which have a shorter warranty period:

- viii) Hydraulic gate operator drive wheels, including XtremeDrive™ wheels and rack: Two Years from date of installation;
- ix) AC and DC power supplies, chargers, and inverters: Two Years from date of installation, except batteries;
- x) Batteries: One Year from date of shipment by Nice;
- xi) Components subject to normal wear including, but not limited to, chains, belts, idler wheels, sprockets and fuses: One Year from date of installation.

## 1(b) Nice Products Not Purchased Through an Authorized Distributor or Not Properly Registered within 60 Days

For any Product that is not purchased from an authorized distributor or for which the Product registration was not completed by the Dealer/Installer/End User within sixty (60) days of the date of purchase, the following warranty will apply: Nice warrants that the Product will remain serviceable under this warranty for the following periods, which begin on the date that the Product was shipped by Nice:

- (i) All gate operators: One Year or 100,000 gate cycles, whichever occurs first.
- ii) AC and DC power supplies, chargers, or inverters: One Year from date of installation.
- iii) Hydraulic gate operator drive wheels: One Year from date of installation.

## 1(c) Replacement Parts

Nice warrants that replacement parts for Products (whether new or reconditioned) will remain serviceable under this warranty for One Year from the date that the part was shipped by Nice or the remaining period of the Product warranty, whichever is longer.

## 1(d) Limitations and Exclusions Applicable to Each of the Preceding Warranties.

The preceding warranties shall not apply to equipment that has been (1) installed, maintained, or used improperly or contrary to instructions; (2) subjected to negligence, accident, vandalism, or damaged by severe weather, wind, flood, fire, terrorism or war; or (3) damaged through improper operation, maintenance, storage or abnormal or extraordinary use or abuse. Any modification made to products will void the warranty unless the modifications are approved in writing by Nice in advance of the modification (this exclusion does not apply to normal installation of approved accessories and/or protective devices or sensors). It is the responsibility of the Distributor, Dealer/Installer, or End User to ensure that the software version in the product is maintained to the latest revision level.

The preceding warranties do not extend to accessories when those items carry another manufacturer's name plate and are not a part of the base model. Nice disclaims all warranties for such accessory components, which carry only the original warranty, if any, of their original manufacturer. Nice hereby assigns its rights under such manufacturer warranties—to the extent that such rights exist and are assignable—to Buyer.

The warranties made by Nice herein extend to Nice's Distributors, to the Dealer/Installer, and to the first End User of the product following installation. They do not extend to subsequent purchasers.

The warranties herein do not apply to Mighty Mule-branded products and components.

## 2. Exclusion of Other Warranties.

The warranties contained in Section 1 are the exclusive warranties given by Nice and supersede any prior, contrary or additional representations, whether oral or written. Any prior or extrinsic representations or agreements are discharged or nullified. NICE HEREBY DISCLAIMS AND EXCLUDES ALL OTHER WARRANTIES—WHETHER EXPRESS, IMPLIED, OR STATUTORY—INCLUDING ANY WARRANTY OF MERCHANTABILITY, ANY WARRANTY OF FITNESS FOR A PARTICULAR PURPOSE, ANY LIABILITY FOR INFRINGEMENT, AND ANY WARRANTIES OTHERWISE ARISING FROM COURSE OF DEALING, COURSE OF PERFORMANCE, OR USAGE OF TRADE.

## 3. Buyer's Exclusive Remedies for Any Nonconformity.

If a Nice Product fails to conform to the warranties in Section 1, Buyer must notify and order replacement parts from the Distributor through which the Product was purchased within a reasonable time and in no event more than thirty (30) days after the discovery of the nonconformity. Nice will investigate and, in the event of a breach, will provide, within a reasonable period of time, one of the following remedies to be selected by Nice in its sole and absolute discretion:

- (1) repair or replacement of any nonconforming Products or Product components or
- (2) refund of the price upon return of the nonconforming items. Nice reserves the right to supply used or reconditioned material for all warranty claims. Nice will not be considered to be in breach of or default under this Warranty because of any failure to perform due to conditions beyond its reasonable control, including any force majeure event. This warranty does not cover any incidental expenses, including fines or penalties, temporary security, labor, shipping, travel time or standby time that are incurred for inspection or replacement of any nonconforming items. As a condition of warranty coverage, warranty claims must be submitted in accordance with the procedures described on the Nice form, "RMA Procedures."

THE REMEDY SELECTED BY NICE IN ACCORDANCE WITH THIS PARAGRAPH SHALL BE THE EXCLUSIVE AND SOLE REMEDY OF BUYER FOR ANY BREACH OF WARRANTY.

## 4. Exclusion of Consequential and Incidental Damages.

NICE SHALL NOT BE LIABLE FOR ANY INCIDENTAL, SPECIAL, OR CONSEQUENTIAL DAMAGES, WHETHER RESULTING FROM NONDELIVERY OR FROM THE USE, MISUSE, OR INABILITY TO USE THE PRODUCT OR FROM DEFECTS IN THE PRODUCT OR FROM NICE'S OWN NEGLIGENCE. This exclusion applies regardless of whether such damages are sought for breach of warranty, breach of contract, negligence, or strict liability. This exclusion does not apply to claims for bodily injury or death.

## 5. Severability.

If any provision of this warranty is found to be invalid or unenforceable, then the remainder shall have full force and effect.

## 6. Proprietary Rights.

Nice retains and reserves all right, title, and interest in the intellectual property rights of its products, including any accompanying proprietary software. No ownership of any intellectual property rights in the products or accompanying software is transferred to Distributor, Dealer/Installer, or End User.

## 7. Applicable Law.

This warranty will be interpreted, construed, and enforced in all respects in accordance with the laws of the State of Washington, without reference to its choice of law principles. The U.N. Convention on Contracts for the International Sale of Goods will not apply to this warranty.

# Specifications

## SWINGSMART™ 535 MODEL, AC OR SOLAR

<b>Model</b>	SwingSmart 535
<b>Single or Twin</b>	Single leaf
<b>Duty Cycle</b>	Continuous
<b>Horsepower</b>	Equivalent to 1/2 hp
<b>Drive</b>	Electromechanical - 24V Brushless DC motor with direct drive gear train
<b>Open/Close Time</b>	Open/Close speed set independently
<b>Gate Length Max.</b>	20 ft (6 m) each leaf
<b>Gate Weight Max.</b>	1,300 lb (590 kg) for 12 ft (4 m) leaf; 800 lb (363 kg) for a 16 ft (5 m) leaf; 600 lb (272 kg) for a 20 ft (6 m) leaf
<b>UPS Battery Backup Cycles</b>	Field configurable to fail open or secure when batteries deplete. Standard battery backup gate travel: Two 12V 8Ah batteries. Up to 300 cycles after AC power loss. Extended battery backup gate travel: Two 12V 35Ah batteries. Up to 1,000 cycles after AC power loss.*
<b>Temperature Rating</b>	-13° to 158° F (-25° to 70° C)
<b>Operating Voltage</b>	24VDC
<b>Input Voltage</b>	Switch select 115V or 208-230V, 60/50 Hz; Solar: 24V solar panels
<b>Accessory Power</b>	24VDC at each input & SS relay (2A accumulative)
<b>Included Accessories</b>	One Nice EPMOB through-beam photo eye with BlueBUS technology, and two 8Ah batteries for backup power and OXI MegaCode receiver.
<b>Communication</b>	BlueBUS, USB, Ethernet, T4, RS-485, Bluetooth, OXI receiver
<b>User Controls</b>	SmartTouch 725 Controller with 70+ configurable settings. 32 character OLED display and 7 tactile buttons, or Bluetooth smartphone interface, for programming.
<b>Inputs</b>	15 inputs including 5 control inputs, 2 dedicated entrapment sensor inputs, 3 user programmable inputs, a BlueBUS port, and 4 Hy5B vehicle detectors sockets. Optional SmartTouch™ I/O Expansion module for 8 additional user programmable inputs.
<b>Relays</b>	3 configurable user relays: Two - 30VDC, 2A solid state. One 250VAC, 20A electromechanical; Optional SmartTouch I/O Expansion module for 8 additional relay outputs.
<b>Finish</b>	Zinc rich primer with black powder coated chassis. High impact copolymer cover.
<b>ETL Listed (UL 325)</b>	Usage Class I, II, III, IV
<b>Warranty</b>	5 year (7 year single-family residential) w/product registration

\* The actual number of gate cycles available from battery depends upon gate resistance to travel, cycle length, battery size, state of charge and health, ambient temperature, accessory power draw, and frequency of gate cycles during power outage.

### Contact Information:

Visit [support.hysecurity.com](http://support.hysecurity.com) for Installation manuals, replacement part instructions, part diagrams and more.

Qualified Nice | HySecurity distributors are experienced and trained to assist in resolving installation problems. For the name of a qualified distributor near you, call HySecurity at 800-321-9947. \*Before contacting your distributor or HySecurity Technical Support, obtain the serial number of your operator.



**Technical Support**

253-201-2918  
Monday - Friday, 6:00 a.m. - 4:00 p.m. PST

**Nice North America | HySecurity**

Gate & Barrier Division  
6705 S 209th St, Ste 101  
Kent, WA, 98032



**Niceforyou.com**