

# Mercury 310

SolarBOX and ACBox  
with Mercury 310 Controller  
**User Guide**

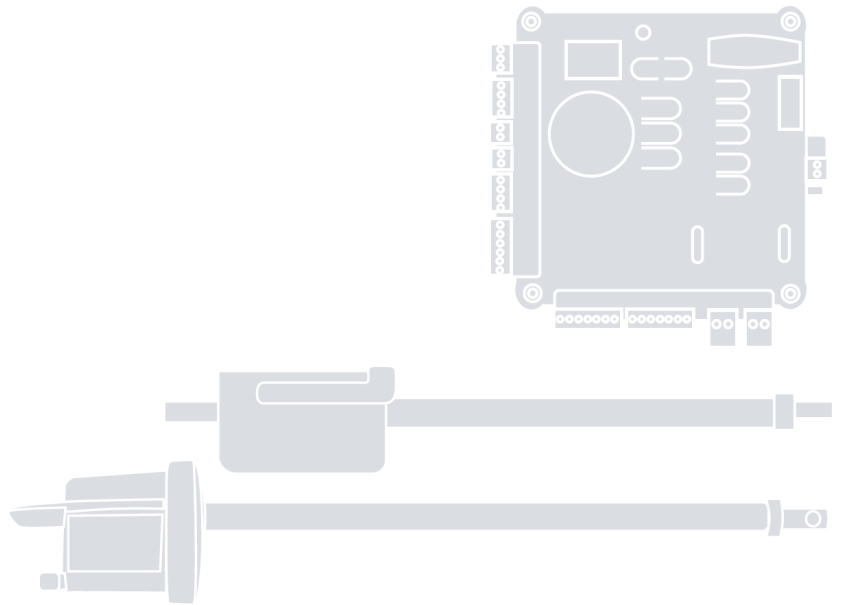

**Controller**

EN - User Guide

**Nice**

# MERCURY 310 Controller

## User Guide

---

## CONTENTS

<b>1. Introduction .....</b>	<b>3</b>
1.1 ACBOX 310 Control Box .....	4
1.2 SolarBOX 310 Control Box.....	4
<b>2. Definitions and Terms .....</b>	<b>5</b>
<b>3. Important Safety Information.....</b>	<b>6</b>
<b>4. User Controls &amp; Indicators.....</b>	<b>14</b>
4.1 Gate Control Buttons .....	15
4.2 Power Status LEDs .....	16
4.3 Fail-safe and Alarm Buttons.....	17
<b>5. OXI Radio and Transmitter Setup .....</b>	<b>18</b>
5.1 Deleting Transmitters.....	19
<b>6. Error and Stop Codes .....</b>	<b>20</b>
6.1 Error Codes .....	20
6.2 Stop Codes .....	21
6.3 Sensor LED Flash Codes .....	21
6.4 Radio Programming Display Codes ..	21
<b>7. Manual Operation.....</b>	<b>22</b>
7.1 Apollo 816 Actuator.....	22
7.2 Titan 912 Linear Actuator .....	23
<b>8. Maintenance .....</b>	<b>24</b>

# MERCURY 310 Controller

## User Guide

### 1. INTRODUCTION

#### NOTICE

The information in this user guide is provided under the assumption that the gate system has been installed and set up by an automated gate installation professional aware of all necessary safety and mechanical requirements.

It is very important to heed safety warnings, as an improperly operated gate system can cause serious injury or death to persons or animals. **READ ALL SAFETY WARNINGS AND CAUTIONS!**

Thank you for choosing a HySecurity | Nice automatic gate opener system! This user guide provides the following information to the end user:

- Important safety information
- Description of the user controls
- Manual linear actuator release instructions
- Error and Stop codes to aid in troubleshooting

Operation is the same for both dual and single gate installations. There are other features that may have been installed, such as loop sensors or remote control devices, so it is important for you to refer to your professional automated gate installer for important information regarding such features.

#### NOTICE

The SolarBOX 310 control box features a lock and key for the external gate control button on the chassis. The cover may also be secured with a padlock if your installer was instructed to do so.

Ensure that the installer hands you the keys and shows you how to use them. Store them in a secure place.



#### WARNING

Disconnect the operator from power (both DC/Solar & Battery) when installing any accessory or external entrapment sensor.

#### Contact Information:

Visit <https://support.hysecurity.com/hc/en-us> for installation manuals, replacement part instructions, part diagrams and more. Qualified Nice | HySecurity distributors are experienced and trained to assist in resolving installation problems.

For the name of a qualified distributor near you, call Nice | HySecurity at 800-321-9947. \*Before contacting your distributor or Nice | HySecurity Technical Support, obtain the serial number of your operator.

# MERCURY 310 Controller

## User Guide

### 1.1 ACBOX 310 Control Box

The ACBOX 310 is powered by a AC-to-DC power supply with a rechargeable 12V back-up battery. To open, unlatch the two latches and open cover as shown (Figure 1).

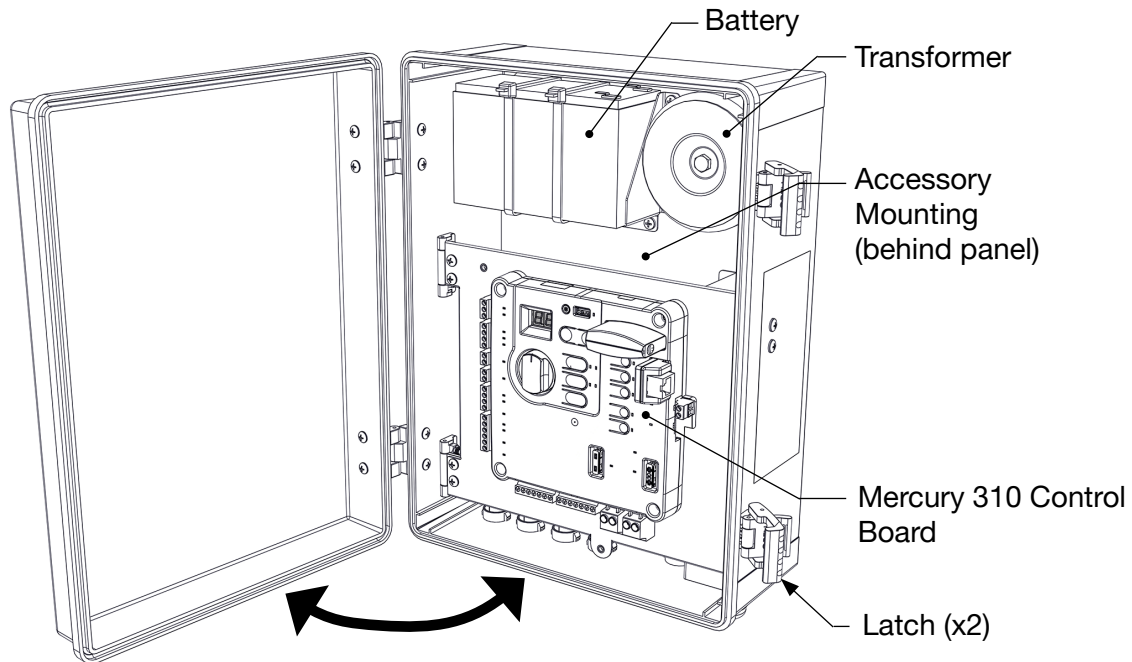

**FIGURE 1: ACBOX 310 Control Box Features**

### 1.2 SolarBOX 310 Control Box

The SolarBOX 310 is powered by a solar panel, with internal space for a rechargeable 12V back-up battery. To open, unlock (if locked), then swing out cover and pull it downward to remove it from the chassis (Figure 2).

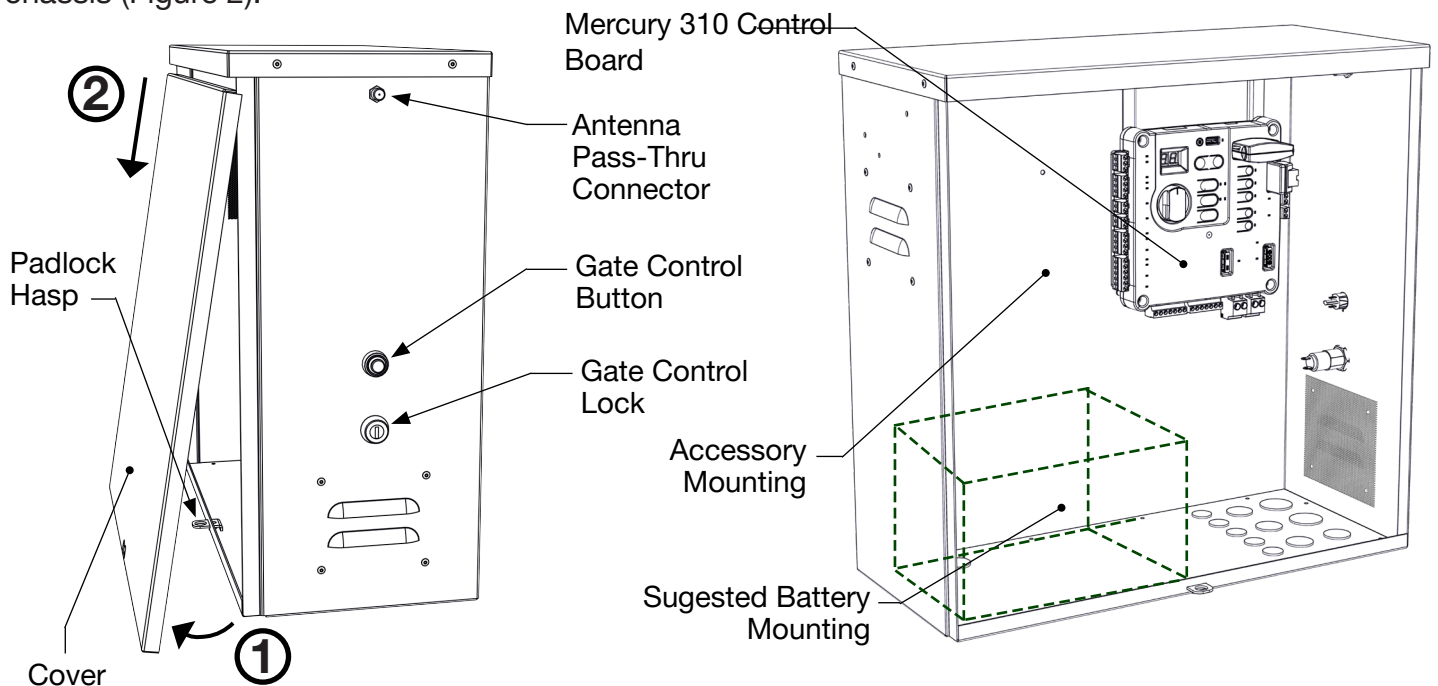

**FIGURE 2: SolarBOX 310 Control Box Features**

# MERCURY 310 Controller

## User Guide

## 2. DEFINITIONS AND TERMS

<b>Linear Actuator</b>	The motor driven device attached to the gate, which mechanically opens the gate.
<b>Controller</b>	The electronic device in the control box used to control the gate functions.
<b>Control Box</b>	The fixed enclosure where the control board, power connections, and actuator connections are located.
<b>Close-Direction</b>	The direction the gate moves when it is closing.
<b>Close Limit</b>	The gate position where the gate is programmed to stop after a CLOSE command.
<b>Edge Sensor</b>	A safety device, which uses a pressure sensitive strip placed along an edge to sense when the edge contacts an object.
<b>Entrapment Zone</b>	Any area where the gate comes within 16” of an immovable object thus presenting a possible entrapment hazard to people and animals.
<b>Close-Direction</b>	The direction the gate moves when it is closing.
<b>Open Limit</b>	The gate position where the gate is programmed to stop after an OPEN command.
<b>Photo Eye</b>	A safety device, which uses the interruption of a beam of light to indicate the presence of an object in an entrapment zone.
<b>Steet Side</b>	The side of the gate installation outside the gated property. Same as “Public Side”.
<b>Secure Side</b>	The side of the gate installation inside the gated property. Same as “Private Side”.
<b>Loop Sensor</b>	A loop of wire buried in the ground which senses the presence of metal objects (i.e. vehicles).
<b>AC Power</b>	Electrical power (Alternating Current) from a common mains power source.
<b>DC Power</b>	Electrical power (Direct Current) from a battery or solar panel.
<b>Solar Power</b>	DC power (Direct Current) from a solar panel.
<b>Single Gate</b>	A gate system with only one gate.
<b>Dual Gate</b>	A gate system with two gates operating together.

# MERCURY 310 Controller

## User Guide

### 3. IMPORTANT SAFETY INFORMATION

#### SAFETY MESSAGES

The safety messages below inform you about potential hazards that can result in injury. Safety messages specifically address level of exposure to operator and are preceded by one of four words: **DANGER**, **WARNING**, **CAUTION**, or **NOTICE**.

#### **DANGER**

Indicates a hazardous situation which, if not avoided, **WILL** result in **DEATH** or **SERIOUS INJURY**.

#### **WARNING**

Indicates a hazardous situation which, if not avoided, **COULD** result in **DEATH** or **SERIOUS INJURY**.

#### **CAUTION**





Indicates a hazardous situation which, if not avoided, **COULD** result in **MINOR** or **MODERATE INJURY**.

#### **NOTICE**

Addresses practices not related to personal injury. Indicates damage to equipment is probable if the hazardous situation is not avoided.

#### COMMON INDUSTRIAL SYMBOLS

These international safety symbols may appear on product or in its literature to alert of potential personal injury hazards. Obey all safety messages that follow these symbols to avoid possible injury or death.

Symbol	Safety Hazard
	Attention - Take Notice
	Danger - Keep Away
	Entrapment Zone
	Possible Pinch Point

#### IMPORTANT SAFETY INSTRUCTIONS

Hazards, associated with automatic gates, can be reduced with proper site design, installation, and use. Installers, maintenance crews, and owners/users must read and follow the safety requirements found in HySecurity® product manuals.



It is important that only qualified installers handle installation of HySecurity Gate vehicular gate operators. A “qualified” installer has one of the following:



1. A minimum of three years experience installing similar equipment.
2. Proof of attending a HySecurity Technical Training seminar within the past three years.
3. Significant manufacturer endorsements of technical aptitude in gate operator installation and operation.

Underwriter Laboratories (UL) and the American Society for Testing and Materials (ASTM) are responsible for current safety standards and regulations regarding gate operators and automated gates. All aspects of gate installation must comply with the appropriate safety standard. For the most up-to-date ASTM F2200 Gate and Fence Standards, refer to [www.astm.org](http://www.astm.org). For UL 325 Safety Standard, refer to [www.ul.com](http://www.ul.com). Consult local government agencies for up-to-date rules and regulations as certain municipalities have established licensing, codes or regulations that regulate automated gate system design and installation.

#### GENERAL SAFETY INFORMATION

A gate operator is only a component in a gate system. The other parts of the gate system can include the gate, the external safety sensors, access controls, and vehicle detectors. To have a gate system that provides for safety, security, and reliable operation it is essential these components operate together as a system. It is the responsibility of the system designer and/or installer to ensure any safety or operational issues have been addressed.

# MERCURY 310 Controller

## User Guide

### **WARNING**

To reduce the risk of injury or death:

1. READ AND FOLLOW ALL INSTRUCTIONS.
2. Never let children operate or play with gate controls. Keep the remote control away from children.
3. Always keep people and objects away from the gate. NO ONE SHOULD CROSS THE PATH OF THE MOVING GATE.
4. Test the gate operator monthly. The gate MUST reverse on contact with a rigid object or stop when an object activates the non-contact sensors. After adjusting the force or the limit travel, retest the gate operator. Failure to adjust and retest the gate operator can increase the risk of injury or death.
5. Use the manual release only when the gate is not moving.
6. KEEP GATES PROPERLY MAINTAINED. Read the user's manual. Have a qualified service person make repairs to gate hardware.
7. The entrance is for vehicles only. Pedestrians must use separate entrance.
8. SAVE THESE INSTRUCTIONS.

### IDENTIFYING GATE OPERATOR CATEGORY AND UL 325 USAGE CLASS

The UL 325 standard covers gate operators. Within this safety standard several Usage Classes are described that define different types of installations where gate operators can be applied. Some operators are restricted in their usage application. Appropriate Usage Classes are shown in the Specifications.

Class I



Class I: Intended for use in a location of one to four single family dwellings or a parking area associated with one to four single family dwellings.

Class II



Class II: Intended for use in a commercial location or building such as a multi-family housing units (five or more single family units) hotels, garages, retail stores or other buildings servicing general public.

Class III



Class III: Intended for use in an industrial location or building such as factories or loading docks or other locations not accessible by the general public.

Class IV



Class IV: Intended for use in guarded industrial locations or buildings such as an airport security area or other restricted access location, not servicing general public, in which access is monitored by security personnel or via closed circuitry.

# MERCURY 310 Controller

## User Guide

### VEHICULAR TRAFFIC ONLY

#### WARNING

This automatic gate operator is not designed nor is it intended for pedestrian traffic. Vehicular gate operators must by their nature be powerful to function reliably. This power can cause injury or death. Accordingly, direct all pedestrian traffic to a separate walk-through gate.

#### Install this gate operator only when:

- The operator is appropriate for the construction of the gate and the usage Class of the gate.
- All openings of a horizontal slide gate are guarded or screened from the bottom of the gate to a minimum of 1.83 m (6 ft) above the ground to prevent a 57.2 mm (2-1/4 in) diameter sphere from passing through the openings anywhere in the gate, and in that portion of the adjacent fence that the gate covers in the open position.
- All exposed pinch points are eliminated or guarded.
- Guarding is supplied for exposed rollers.

The operator is intended for installation only on gates used for vehicles. Pedestrians must be supplied with a separate access opening. The pedestrian access opening shall be designed to promote pedestrian usage. Locate the gate such that persons will not come in contact with the vehicular gate during the entire path of travel of the vehicular gate.

The gate must be installed in a location so that enough clearance is supplied between the gate and adjacent structures when opening and closing to reduce the risk of entrapment. Swinging gates shall not open into public access areas.

The gate must be properly installed and work freely in both directions prior to the installation of the gate operator. Do not over-tighten the operator clutch or pressure relief valve to compensate for an improperly installed, improperly functioning, or damaged gate.

Permanently mounted controls intended for user activation must be located at least 1.83 m (6 ft) away from any moving part of the gate and where the user is prevented from reaching over, under, around, or through the gate to operate the controls.

- Exception: Emergency access controls only accessible by authorized personnel (e.g. fire, police, EMS) may be placed at any location in the line-of-sight of the gate.

The Stop and/or Reset button must be located in the line-of-sight of the gate. Activation of the reset control shall not cause the operator to start.

A minimum of two (2) WARNING SIGNS shall be installed, in the area of the gate. Each placard is to be visible by persons located on the side of the gate on which the placard is installed.

#### For gate operators utilizing a non-contact sensor (Photo Eye):

- See instructions on the placement of non-contact sensors for each type of application.

- Care shall be exercised to reduce the risk of nuisance tripping, such as when a vehicle trips the sensor while the gate is moving.
- One or more non-contact sensors shall be located where the risk of entrapment or obstruction exists, such as the perimeter reachable by a moving gate or barrier.

#### For a gate operator utilizing a contact sensor (Edge):

- One or more contact sensors shall be located where the risk of entrapment or obstruction exists, such as at the leading edge, trailing edge, and post mounted both inside and outside of a vehicular horizontal slide gate.
- A hardwired contact sensor shall be located and its wiring arranged so that the communication between the sensor and the gate operator is not subjected to mechanical damage.
- A wireless device such as one that transmits radio frequency (RF) signals to the gate operator for entrapment protection functions shall be located where the transmission of the signals are not obstructed or impeded by building structures, natural landscaping or similar obstruction. A wireless device shall function under the intended end-use conditions.
- One or more contact sensors shall be located on the inside and outside leading edge of a swing gate. Additionally, if the bottom edge of a swing gate is greater than 152 mm (6 in) but less than 406 mm (16 in) above the ground at any point in its arc of travel, one or more contact sensors shall be located on the bottom edge.

### USE OF VEHICLE DETECTORS

Use of vehicle detectors (loop detectors) is strongly encouraged to prevent damage to vehicles caused by gates closing on them. This is not considered to be a safety item as vehicle detectors cannot provide protection to pedestrians. In some situations, photoelectric devices may be used as vehicle detectors, but should be wired accordingly.

### GATE CONSTRUCTION AND SAFETY

Gate construction plays a very important role in ensuring the safety of any automated gate system. The standard for gate construction is ASTM F2200. Below are key areas to address in gate design for safety. For complete information consult the standard. Copies of the standard are available at:

<https://www.astm.org/Standards/F2200.htm>.

# MERCURY 310 Controller

## User Guide

---

Another source of information is available from DASMA, the Door and Access System Manufacturer's Association. The Association publishes Technical Data Sheets, one of which concerns ASTM F2200. For more information, see:

<http://www.dasma.com/PDF/Publications/TechDataSheets/OperatorElectronics/TDS370.pdf>.

### General Requirements for Gate Construction:

- Gates shall be constructed in accordance with the provisions given for the appropriate gate type listed. Refer to ASTM F2200 for additional gate types.
- Gates shall be designed, constructed and installed to not fall over more than 45 degrees from the vertical plane, when a gate is detached from the supporting hardware.
- Gates shall have smooth bottom edges, with vertical bottom edged protrusions not exceeding 0.50 in (12.7 mm) other than the Exceptions listed ASTM F2200.
- The minimum height for barbed wire shall not be less than 6 ft (1.83 m) above grade. The minimum height for barbed tape shall not be less than 8 ft (2.44 m) above grade.
- An existing gate latch shall be disabled when a manually operated gate is retrofitted with a powered gate operator.
- A gate latch shall not be installed on an automatically operated gate.
- Protrusions shall not be permitted on any gate. Consult ASTM F2200 for exceptions.
- Gates shall be designed, constructed and installed such that their movement shall not be initiated by gravity when an automatic operator is disconnected.
- For pedestrian access in the vicinity of an automated vehicular gate, a separate pedestrian gate shall be provided. The pedestrian gate shall be installed in a location such that a pedestrian shall not come in contact with a moving vehicular access gate. A pedestrian gate shall not be incorporated into an automated vehicular gate panel.
- Any non-automated gate that is to be automated shall be upgraded to conform to the provisions of this specification.
- This specification shall not apply to gates generally used for pedestrian access and to vehicular gates not to be automated.
- Any existing automated gate, when the operator requires replacement, shall be upgraded to conform to the provisions of this specification in effect at that time.

### The following provisions shall apply to Class I, Class II, Class III, and Class IV vehicular horizontal swing gates:

Gates shall be designed, constructed and installed so as not to create an entrapment area between the gate and the supporting structure or other fixed object when the

gate moves toward the fully open position, subject to the following provisions.

The width of an object (such as a wall, pillar or column) covered by a swing gate when in the open position shall not exceed 4 inches (102 mm), measured from the centerline of the pivot point of the gate. Exception: For a gate that is not in compliance with this provision, the defined area shall be subject to the entrapment protection provisions of UL 325.

Except for the zone specified above the distance between a fixed object such as a wall, pillar or column, and a swing gate when in the open position shall not be less than 16 inches (406 mm). Exception: For a gate that is not in compliance with this provision, the defined area shall be subject to the entrapment protection provisions of UL 325.

### EXTERNAL ENTRAPMENT PROTECTION SENSORS

Most Nice | HySecurity gate operators are equipped with a Type A, Inherent Entrapment Sensor (IES). UL 325 Safety Standard compliance requires an additional means of entrapment protection that includes installation of external entrapment protection sensors, the number of which depends on entrapment hazards that exist at each particular installation.

To comply with UL 325, the following external sensors may be used:

- Contact sensors, such as edge sensors
- Non-contact sensors, such as photo eyes
- Built-in Type C device (Mercury 310 only)

Site designer or installer can choose photo eyes, edge sensors, internal Type C sensor, or a combination of these devices. Whatever devices are used, protection in both opening and closing directions of gate travel must be provided, as well as and where a risk of entrapment is present.

UL 325 Safety Standard for automatic sliding gates specifically requires that edge sensors, photo eyes, or a combination of both devices be installed to protect against pedestrian entrapment in BOTH directions of gate travel and wherever entrapment hazards exist.

**PHOTO EYES:** One or more non-contact sensor (photo eyes) shall be located where entrapment risk or obstruction exists, such as perimeter reachable by a moving gate.

Care shall be exercised to reduce the risk of nuisance tripping, such as when a vehicle trips the sensor while the gate is moving.

# MERCURY 310 Controller

## User Guide

---

**EDGE SENSORS:** One or more contact sensors (edge sensors) shall be located at leading edge, trailing edge, and post-mounted, both inside and outside of a sliding gate.

One or more contact sensors shall be located on the inside and outside leading edge of a swing gate. Additionally, if the bottom edge of a swing gate is greater than 6"(152mm) but less than 16"(406mm) above the ground at any point in its arc of travel, one or more contact sensors shall be located on the bottom edge.

**SENSOR SECURITY:** A hard-wired contact sensor shall be located and its wiring arranged so that communication between sensor and gate is not subjected to mechanical damage.

**TYPE A ENTRAPMENT PROTECTION:** In Type A entrapment protection, the controller monitors the electrical resistance of the actuator motors, so if a moving gate comes up against the physical resistance of an immovable object, it will cause the gate to stop, hence limiting the force.

**TYPE C ENTRAPMENT PROTECTION:** In Type C entrapment protection, the controller monitors the actuator encoder output, and if there is an unexpected decrease in speed, it will cause the gate to stop, hence limiting the force.

**SENSOR FUNCTION and COMMUNICATION:** A wireless sensor that transmits its signal to gate operator must be located so its signal is not impeded by building structures or other obstructions. All sensors must be installed so that they function as intended for end-use conditions.

**UL 325 LISTING:** Edge sensors and photo eyes must be tested and labeled as "Recognized Components" or otherwise certified to UL 325 requirements in order to be deemed acceptable for use in a gate operator. Study Important Safety Instructions and consider your specific installation to determine where greatest entrapment risks exist. Locate edge sensors and/or photo sensors accordingly. Be certain that a sufficient number of sensors are used so that pedestrians are protected from entrapment in both directions of gate travel and all hazard areas are fully protected. Most HySecurity gate operators require external entrapment sensors that utilize Normally Closed (NC) contact means of monitoring. HySecurity gate operators utilizing the SmartTouch Controller require external entrapment sensors that have a 10k Ohm or 4-wire pulsed monitoring scheme. Refer to UL website at [www.ul.com](http://www.ul.com) for most up-to-date list of gate operator safety standards (UL 325). Mercury 310 controller can monitor 10k sensors as well as BlueBus photo eyes.



### CAUTION

A contact or non-contact sensor is also required to protect against possible entrapment if gate opens to a position less than 16 inches (40.6 cm) from any object, such as a post or wall.

---

## RECOMMENDED EXTERNAL ENTRAPMENT PROTECTION SENSORS LIST

### UL 325 Standard:

- The operator shall monitor for the presence of every device at least once during each open and close cycle (32.1.8).
- It shall not be possible to make simple modifications in the field by adding, suppressing or changing, either on the operator or external entrapment protection device(s), to bypass, interfere with, or otherwise defeat the monitoring function. (32.1.10).
- Entrapment zones are now defined for each gate type (4.23, 4.24, 4.29, 4.34).

**Swing Gates:** To enable fully automatic operation, all SWING gate operators will require a minimum of ONE monitored external entrapment protection sensor to protect entrapment zones in either the open or close direction of travel. However, an additional monitored sensor is required if there is a risk of entrapment in both directions of gate travel.

**Preferred solution for swing gates:** A photo eye for the close direction and/or a hard-wired wraparound edge sensor on the leading edge of the gate, which protects for both directions of gate travel.

## IMPORTANT

**Installers must assess each specific site and install sensors that protect all potential entrapment zones.**

For more information visit Gate Safety at [www.hysecurity.com/gatesafety](http://www.hysecurity.com/gatesafety) or see latest operator manuals at <https://support.hysecurity.com/hc/en-us>

# MERCURY 310 Controller

## User Guide

### NOTICE

The following sensors have been tested with Nice | HySecurity gate operators by an independent laboratory and certified to comply with UL 325 7th Edition. Select sensors from this list for UL compliant gate automation solutions. Contact the sensor manufacturer for specific recommendations for use.

Recommended Sensors					Compatible Control Boards				
	Mfg. Part # or Model	Brand	Nice   HySecurity Part #	Max. Range	Smart Touch	Smart DC	SmartTouch 725	1050	Mercury 310
Photo Eyes (Retroreflective)	E3K-R10K4-NR-1	Omron	MX000999	40 ft	•	•	•		
	NIR-50-325	EMX	-	45 ft	•	•	•	•	•
	IRB-RET	EMX	-	53 ft	•	•	•	•	•
	E-931-S50RRGQ	Seco-Larm	-	46 ft	•	•	•		•
Photo Eyes (Thru-Beam)	Blue Bus Era Photo Eyes	Nice   Hysecurity	EPMB/A EPMOB/A	45 ft			•	•	•
	OVS-50TNR	Optex	-	33 ft	•	•			
	IRB-MON	EMX	MX3990	65 ft	•	•	•		•
	E-960-D90GQ	Seco-Larm	-	90 ft	•	•	•		•
Edge Sensors	Sentir Series	ASO Safety	"AS1502-* AS1501-**"		•	•	•	•	•
	CPT210-2U-#-T2	Miller Edge	-		•	•	•	•	•
Edge Sensors Converters	Hy2NC (Converts 10K to NC Monitoring)	HySecurity	MX4018		•	•			
	GEM103 (Converts 10K to Pulsed Monitoring)	Miller Edge	-					•	
Edge Wireless Kits	iGAZE RE Kit	Transmitter Solutions	-		•	•	•	•	•
	WEL-200	EMX	-		•	•	•	•	•
Multi-Input Module	The Solution - MIM-62	Miller Edge	-		•	•	•		•

### SWING GATE POTENTIAL ENTRAPMENT ZONES

1. Leading Edge
2. Bottom Edge Entry/Exit
3. Posts
4. Post Pivot/Pinch Points
5. Arm Movement

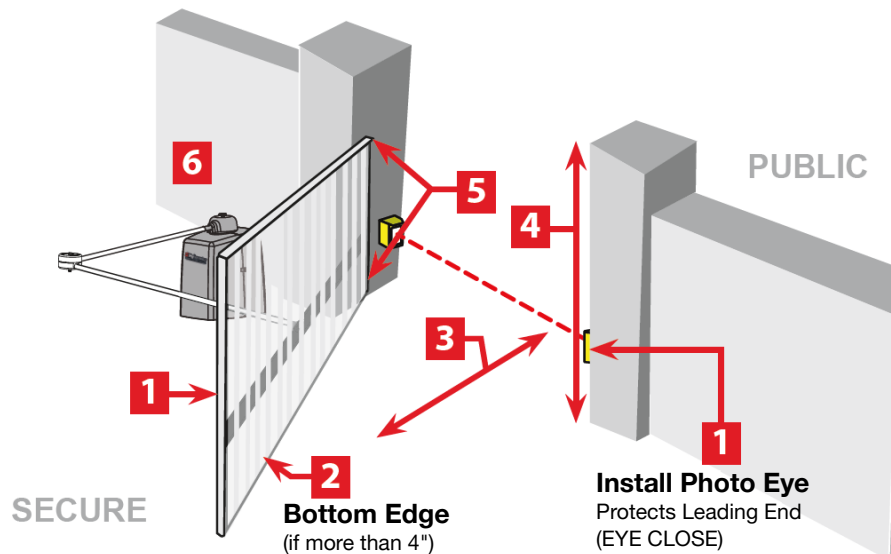

# MERCURY 310 Controller

## User Guide

### ELECTRICAL SAFETY

- Turn gate operator and all circuit breakers OFF before performing maintenance on the gate operator or making contact with output receptacles.
- Never insert any objects into output receptacles during operation. The possibility exists of electrical shock, electrocution, or death.
- Never let power wires lay in water.
- Never use damaged or worn wire when connecting equipment. Inspect for cuts in the insulation.
- Never grab or touch a live power cord or cable with wet hands. The possibility exists of electrical shock, electrocution, or death.
- Always make certain that proper power has been selected for the job. See Cable Selection Chart in this manual.

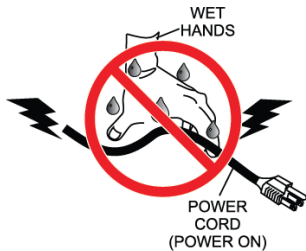

### GROUNDING SAFETY

- Always make sure that electrical circuits are properly grounded to a suitable earth ground (ground rod) per the National Electrical Code (NEC) and local codes. Severe injury or death by electrocution can result from operating an unground operator.
- Never use gas piping as an electrical ground.



### BATTERY SAFETY

HySecurity 535 operators use sealed Absorbed Glass Mat (AGM) batteries and HySecurity highly recommends replacing used batteries with new AGM-type batteries.

#### CAUTION

Batteries used with HySecurity gate operators contain materials considered hazardous to the environment. Proper battery disposal is required by federal law. Refer to *Hazardous Waste Regulations* federal guidelines.

### To reduce risk of fire or injury to persons:

- Observe polarity between batteries and charging circuit.
- Never mix battery sizes, types, or brands. Charging circuit on HySecurity DC operators is designed for AGM-type batteries, not flooded lead acid-type batteries.
- Exercise care in handling batteries. Be aware metal found in rings, bracelets, and keys can conduct electricity, short batteries, and cause potential injury.
- Do not open or mutilate batteries. Battery cells contain corrosive materials which may cause burns and other injuries. Material within batteries is toxic.
- Always dispose of batteries properly. Do not place batteries in fire. Battery cells may explode. Follow federal guidelines for proper disposal of hazardous waste.
- Always keep battery cables in good working condition. Repair or replace all worn cables.
- Replace batteries according to instructions found in DC Battery Replacement.
- Do not charge a frozen battery. Battery can explode. If frozen, warm the battery to at least 61°F (16°C).



### ENVIRONMENTAL SAFETY/HAZARDOUS MATERIAL AND PROPER DISPOSAL

Decommissioning is a controlled process used to safely retire a piece of equipment that is no longer serviceable. If the equipment poses an unacceptable and unreparable safety risk due to wear or damage or is no longer cost effective to maintain (beyond life-cycle reliability) and is to be decommissioned (demolition and dismantlement), be sure to follow rules below.



- Do not pour waste or oil directly onto the ground, down a drain or into any water source.
- Contact your country's Department of Public Works or recycling agency in your area and arrange for proper disposal of any electrical components, waste or oil associated with this equipment.
- When the life cycle of this equipment is over, remove battery and bring to appropriate facility for lead reclamation. Use safety precautions when handling batteries that contain sulfuric acid.

# MERCURY 310 Controller

## User Guide

- When the life cycle of this equipment is over, it is recommended that the frame and all other metal and plastic parts be sent to a recycling center.

Metal and plastic recycling involves the collection of metal and plastic from discarded products and its transformation into raw materials to use in manufacturing a new product.

Recyclers and manufacturers alike promote the process of recycling metal and plastic. Using a metal and plastic recycling center promotes energy cost savings.

### WIND LOAD

When the IES (type A sensor) trips, it sends a signal to gate operator to stop and reverse direction. This feature may be falsely triggered in excessively windy conditions because wind itself, acting over surface area of gate panel, can provide necessary force to trigger IES.

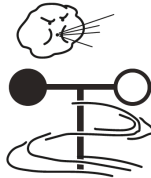

### **!** CAUTION

Do not adjust IES sensitivity/Force setting to accommodate for inappropriately designed gate panels. Loss of IES sensitivity increases mechanical wear on gate hardware and gate operator. It may also pose a safety hazard. Compensating for wind loads by adjusting IES may set IES sensitivity to a level which, when encountering an obstruction, ignores the obstruction and fails to reverse direction.

### MAINTENANCE OF GATE SYSTEMS

To keep your automated gate system performing both safely and reliably it is important to ensure that the components of that system are functioning properly.

#### At least monthly:

- Disconnect the gate operator and manually move the gate through its range of travel. Note any squeaks from rollers or hinges or areas of binding. The gate should travel smoothly and quietly throughout its range. If it does not, contact a gate professional to correct the problem.
- Reconnect the gate operator and perform the following tests:
  - With the gate opening, block any photo eyes and/or depress any safety edges used to protect the open direction. The gate should stop and/or reverse.
  - With the gate closing, block any photo eyes and/ or depress any safety edges used to protect the close direction. The gate should stop and/or reverse.
  - Using a suitable obstruction in the path of the gate (a solid, immovable object), run the gate in the open direction until it contacts the obstruction. The gate should stop and reverse, or it will just stop if a Type C sensor is engaged before the Type A sensor is tripped.
  - Using a suitable obstruction in the path of the gate (a solid, immovable object), run the gate in the close direction until it contacts the obstruction. The gate should stop and reverse, or it will just stop if a Type C sensor is engaged before the Type A sensor is tripped.

# MERCURY 310 Controller

## User Guide

### 4. USER CONTROLS & INDICATORS

- **READ ALL THE SAFETY WARNINGS AND CAUTIONS** on the previous pages before proceeding to operate the gate system!
- This user manual will cover basic operation of the manual operator controls, as well as maintenance and troubleshooting that may be performed by the end user.
- Figure 2, below, shows the Mercury 310 interface with the user specific controls and indicators in green callouts.

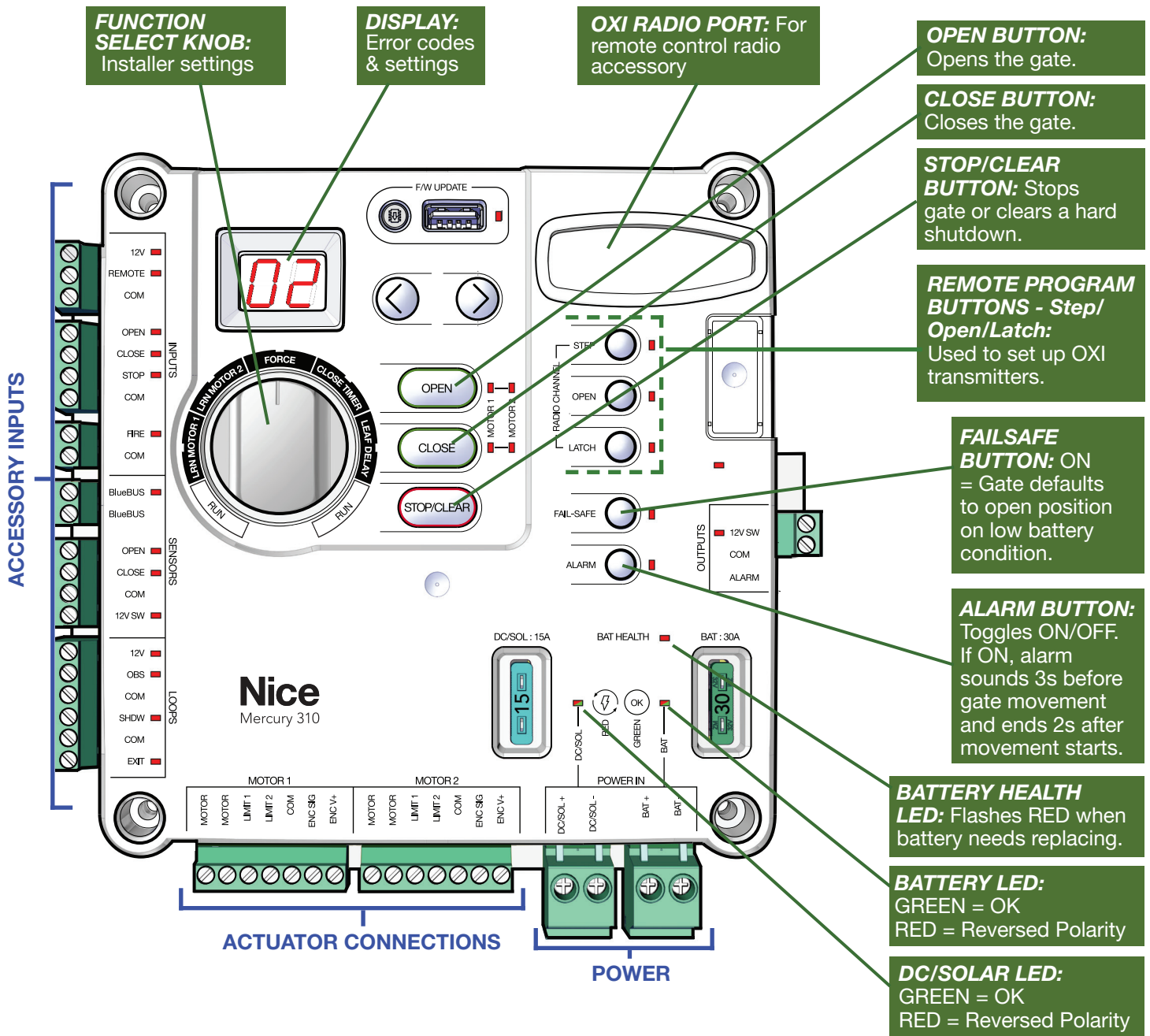

FIGURE 3: Mercury 310 Control Board Interface Features

# MERCURY 310 Controller

## User Guide

### 4.1 Gate Control Buttons

The OPEN, CLOSE, and STOP/CLEAR buttons are used to operate the gate from the control box. Each is described below.

#### OPEN Button

**Press and release** to open the gate.

#### NOTICE

Pressing the OPEN button on a closing gate will reverse gate direction and open the gate.

#### CLOSE Button

**Press and release** to close the gate.

#### NOTICE

Pressing the CLOSE button on an opening gate will reverse gate direction and close the gate.

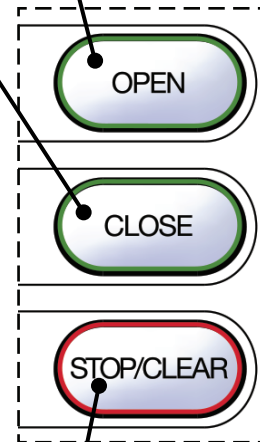

#### STOP/CLEAR Button

- **Press and release** to stop the gate.
- **Press and release** to clear a hard shutdown.
- **Press and hold (3s)** to clear the sensor registry.
- **Press and hold Stop/Clear with Fail-Safe button (3s)** for factory reset to default settings.

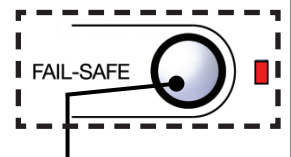

#### NOTICE

- A hard shutdown is when the moving gate encounters an immovable object or a sensor is tripped and the gate system shuts down as a safety measure.
- Hard shutdown will only occur when the Type A sensor is tripped twice, or if a sensor input trips, followed by one Type A sensor trip.

#### CAUTION

DO NOT reset a hard shutdown without first determining what obstructed the gate or tripped a sensor to cause the shutdown and that the situation has been safely resolved!

# MERCURY 310 Controller

## User Guide

### 4.2 Power Status LEDs

The power indication LEDs display the power status for the solar, DC, and battery power sources, and each is described below.

#### Battery Health LED

##### RED LED:

- Glows solid when battery health is OK.
- Flashes when:
  1. No battery connected;
  2. Battery fuse is blown; or
  3. Battery voltage is too low (<10.5V).

#### NOTICE

Battery replacement should only be performed by a professional installer.

#### DC/Solar Power LED

**GREEN** = ON and polarity OK.

**RED** = Polarity reversed.

**OFF** = No power or 15A fuse blown or other hardware failure.

#### Battery Power LED

**GREEN** = ON and polarity OK.

**RED** = Polarity reversed.

**OFF** = No power or other hardware failure.

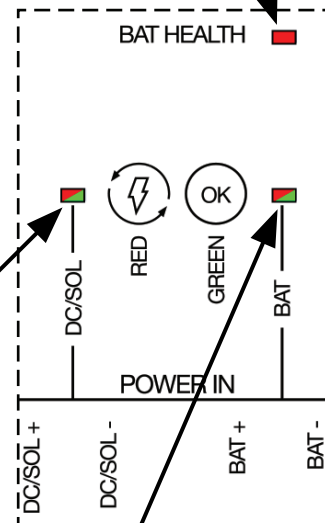

# MERCURY 310 Controller

## User Guide

### 4.3 Fail-safe and Alarm Buttons

The Fail-safe and Alarm buttons operate as described below. These should be set according to user preference.

#### FAILSAFE Button (On/Off)

**RED LED = ON:**

Fail-safe is enabled, and gate will automatically move to the *open limit* if the battery voltage falls below a certain limit.

**RED LED = OFF:**

Fail-secure is enabled and the gate will automatically move to the close limit if the battery voltage falls below a certain limit.

#### NOTICE

An automatically opened gate might not be desirable if gate *security* has a priority over gate access. See **Section 6** for instructions for manually opening a gate in the event of a power failure.

**RED LED = FLASHING:**

When FLASHING, fail-safe or fail-secure is currently activated.

#### NOTICE

- Activation of fail-safe/secure only occurs when the controller is battery powered. This can occur on controllers powered from an AC-DC power supply when AC power is removed.
- Reset of fail-safe/secure will occur automatically when certain conditions are met. If the controller is powered from an AC-DC power supply, then the fail-safe/secure will reset when AC power is restored. If the controller is powered from a battery, then the fail-safe/secure will reset when the battery voltage is above a certain limit for 10 minutes.
- Reset of fail-safe/secure can be done manually when activated by pressing the fail-safe button. However, the fail-safe/secure may be activated again if the battery voltage is still below a certain limit.

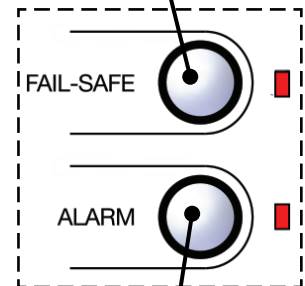

#### ALARM Button (On/Off)

**RED LED = ON:**

When ON, the warn-before-operate alarm will sound for three (3) seconds before the gate starts moving when an OPEN or CLOSE command is made, either by pressing the gate buttons or when a sensor, such as a ground loop, is tripped. The alarm will continue to sound for two (2) seconds after the gate starts moving, then turn off.

#### CAUTION

The alarm connected to the Mercury 310 Controller should never be disconnected! This alarm functions as the entrapment alarm and is a requirement under UL325 regulations.

#### NOTICE

Alarm will sound during safety critical scenarios regardless of this setting.

# MERCURY 310 Controller

## User Guide

### 5. OXI RADIO AND TRANSMITTER SETUP

If the OXIMGC/A receiver module is installed, program transmitters (remote controls) for gate operation as described:

#### IMPORTANT NOTICE

Transmitters (remote controls) must be “learned” by the OXIMGC/A radio receiver before other radio accessories (i.e., wireless keypads) to avoid errors. To reset in event of an error, press & hold down the Program button (on top of OXIMGC/A) and release after green LED flashes five (5) times, then re-learn a remote before other devices.

#### STEP Button (Radio Channel)

Used to program a remote control button to operate like a garage door opener (1st press = Open, 2nd press = STOP, 3rd press = CLOSE). To program:

1. Press and hold the STEP button on the Mercury for 1 second and release.
2. Within 2 seconds, press and hold the desired button on the remote until “dn” is displayed on the Mercury controller.

If programming is successful, **dn** (done) is displayed, the STEP LED will flash twice, and the alarm will chirp for successful pairing. If programming fails, error code **ER + 08** is displayed.



OXIMGC/A Radio Receiver Module & 3-Button Remote

#### OPEN Button (Radio Channel)

Used to program a remote control button to open the gate:

1. Press and hold the OPEN button on the Mercury for 1 second and release.
2. Within 2 seconds, press and hold the desired button on the remote until “dn” is displayed on the Mercury controller.

If programming is successful, **dn** (done) is displayed, the STEP LED will flash twice, and the alarm will chirp for successful pairing. If programming fails, error code **ER + 08** is displayed.

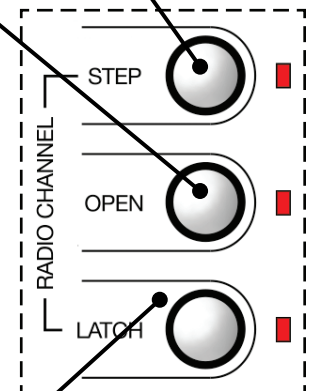

#### NOTICE

The Open function will only open a gate or reverse a closing gate; it will not have any effect on a gate in Hard Shutdown.

#### LATCH Button (Radio Channel)

Programs remote button to “latch” gate in open or closed position until button is pressed a second time.

1. Press and hold the LATCH button on the Mercury for 1 second and release.
2. Within 2 seconds, press and hold the desired button on the remote until “dn” is displayed on the Mercury controller.

If programming is successful, **dn** (done) is displayed, the STEP LED will flash twice, and the alarm will chirp for successful pairing. If programming fails, error code **ER + 08** is displayed.

#### NOTICE

Latch function will be ignored on a moving gate or a gate stopped in mid-travel. The audio alarm will “chirp” whenever Latch transmitter is activated or gate is locked and an operate command is received and ignored.

# MERCURY 310 Controller

## User Guide

### 5.1 Deleting Transmitters

Transmitters (remote controls) may be deleted from the programming of the OXIMGC/A radio receiver using the Mercury 310 Radio Buttons as follows:

#### **Delete ALL Transmitters:**

Simultaneously press and hold down the Step, Open, and Latch buttons for at least three (3) seconds, until **rE** (Remote Erase All) is displayed. All three LEDs will flash twice.

- If deletion is successful, **dn** (done) is shown in Mercury display.
- If deletion fails, **Er + 09** is shown in Mercury display.

#### **Delete SINGLE Button from Transmitter:**

Press and hold any one of three channel buttons on the Mercury 310 controller for at least three (3) seconds until **rD** (Remote Delete) is displayed, then press the button on the remote to be deleted.

- If deletion is successful, **dn** (done) is shown in Mercury display.
- If deletion fails, **Er + 09** is shown in Mercury display.

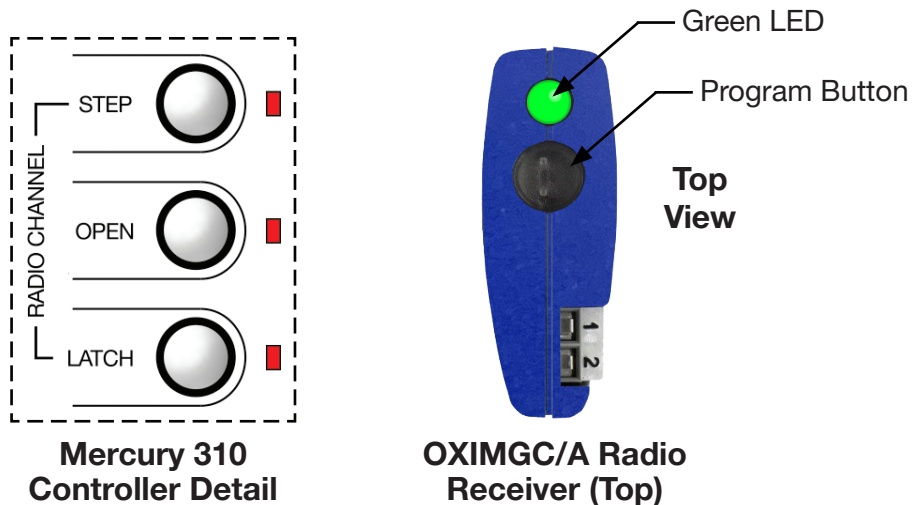

*Mercury 310 Radio Programming Buttons and OXIMGC/A Controls*

# MERCURY 310 Controller

## User Guide

## 6. ERROR AND STOP CODES

### 6.1 Error Codes

Error codes are very useful for communicating information to your gate installer in the event of a gate error. When there is an error, the display will alternately flash Er and a two number code, as shown in the Display column in the table below.

Display	Code	Error Condition	Possible Cause	
Er	01	01	<ul style="list-style-type: none"> <li>Learn limits started without motor 1 connected.</li> <li>Normal gate operation - motor not detected after start.</li> </ul>	<ul style="list-style-type: none"> <li>Motor not connected to motor 1 connector.</li> <li>Wiring fault.</li> <li>Defective motor.</li> <li>Mechanical release is open (Titan 912L).</li> </ul>
	02	02	<ul style="list-style-type: none"> <li>Learn limits started without motor 2 connected.</li> <li>Normal gate operation - motor not detected after start.</li> </ul>	<ul style="list-style-type: none"> <li>Motor not connected to motor 1 connector.</li> <li>Wiring fault.</li> <li>Defective motor.</li> <li>Mechanical release is open (Titan 912L).</li> </ul>
	03	03	Normal gate operation - Encoder frequency below nominal.	<ul style="list-style-type: none"> <li>Obstruction preventing gate movement.</li> <li>Wiring fault.</li> <li>Defective encoder.</li> </ul>
	04	04	Normal gate operation - Motor current exceeds force threshold.	<ul style="list-style-type: none"> <li>Obstruction preventing gate movement.</li> <li>Wiring fault.</li> <li>Defective motor.</li> </ul>
	05	05	IES Type A activated twice prior to reaching a limit.	<ul style="list-style-type: none"> <li>Obstruction preventing gate movement.</li> <li>Defective motor.</li> </ul>
	06	06	Learn limits started when the motor is at limit.	<ul style="list-style-type: none"> <li>Learn limits started when motor is at limit.</li> <li>Wiring fault.</li> </ul>
	07	07	Learn limits started and an encoder is not detected.	<ul style="list-style-type: none"> <li>Learn limits started and an encoder not detected.</li> <li>Wiring fault.</li> </ul>
	08	08	Programming OXI Step, Open, or Latch to key FOB failed.	<ul style="list-style-type: none"> <li>OXI not plugged in.</li> <li>Key FOB Button not pushed.</li> <li>Key FOB Button not detected by OXI receiver.</li> </ul>
	09	09	Erasing single button or all FOBs failed.	<ul style="list-style-type: none"> <li>OXI not plugged in.</li> <li>Key FOB Button not pushed.</li> <li>Key FOB Button not detected by OXI receiver.</li> </ul>
	10	10	<ul style="list-style-type: none"> <li>OXI not connected.</li> <li>OXI communication error with Mercury</li> </ul>	OXI not plugged in.
	11	11	Battery voltage too low.	<ul style="list-style-type: none"> <li>Battery voltage below 12.5V without gate cycle during battery health check.</li> <li>Battery voltage below 12.0V with gate cycle during battery health check.</li> </ul>
	12	12	12V Regulator Failure.	Defective component.
	13	13	Accessory power (unswitched) fuse tripped.	Excessive current draw. (Disconnect accessory power, restart controller, reconnect.)
	14	14	Accessory power (switched) fuse tripped.	Excessive current draw. (Disconnect accessory power, restart controller, reconnect.)
	15	15	Alarm fuse tripped.	Excessive current draw. (Disconnect accessory power, restart controller, reconnect.)

# MERCURY 310 Controller

## User Guide

### 6.1 Error Codes (continued)

Display	Code	Error Condition	Possible Cause	
Er	16	16	24V Power Supply failure.	Defective component. (Only for Mercury 500 series.)
	17	17	Lock fuse failure.	Excessive current draw. (Only for Mercury 500 series.)
	18	18	Open & Close Limits active at same time.	Open & Close Limits both active. Check connections.
	19	19	DC input voltage too high at motor start.	<ul style="list-style-type: none"> <li>DC input voltage is greater than 25V and no battery is connected.</li> <li>AC/DC power supply problem.</li> </ul>
	20	20	Battery input voltage too high. <b>NOTE:</b> Error 20 available only in Mercury 310 Firmware version h7.01.	DC/SOL connector swapped with BAT connector. Verify wiring for power input connectors.

### 6.2 Stop Codes

When a gate stops because of an input, one of the following two digit codes will show in the display to indicate which input caused the gate to stop.

Display	Code	Description
oE	oE	<b>Open Entrapment:</b> Entrapment sensor connected to Open Sensor input is active and preventing gate from opening.
cE	cE	<b>Close Entrapment:</b> Entrapment sensor connected to the Close Sensor input is active and preventing gate from closing.
bo	bo	<b>BlueBus Open:</b> BlueBus device in Open direction is active and preventing gate from opening.
bc	bc	<b>BlueBus Close:</b> BlueBus device in Close direction is active and preventing gate from closing.
FS	FS	<b>Fail-Safe (or Fail-Secure):</b> BlueBUS Close sensor preventing gate operation.

### 6.3 Sensor LED Flash Codes

LEDs indicate the status of inputs and outputs as follows:

- LED **OFF** = Inactive
- LED **ON** = Active
- LED **FLASHING** = Error or preventing operation

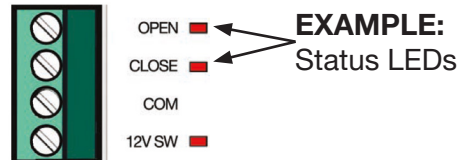

### 6.4 Radio Programming Display Codes

When programming the OXI receiver and remote(s), the current program status is displayed (see table below).

Display	Code	Description
rA	rA	<b>Remote Add:</b> Learn a single remote button.
rd	rd	<b>Remote Delete:</b> Remove a single button function from a remote.
rE	rE	<b>Remote Erase All:</b> Erase all remotes from OXI radio.

# MERCURY 310 Controller

## User Guide

### 7. MANUAL OPERATION

To manually open the gate in the event of a full power outage, follow the instructions in this section according to the type of actuator in your kit.

#### 7.1 Apollo 816 Actuator

##### Manual Release Instructions: Apollo 816 Linear Actuator

1. Pull the R-Clip from the hole in the hitch pin (See illustration below).
2. Pull the hitch pin from the gate bracket and actuator arm.
3. Swing the actuator assembly entirely out of the way and the gate can now be moved by hand.
4. Reverse the procedure to re-affix the actuator to the gate.

##### NOTICE

This procedure will only work if the gate has been installed using the hitch pin and R-clip. Contact your gate installer to disconnect or replace other hardware configurations.

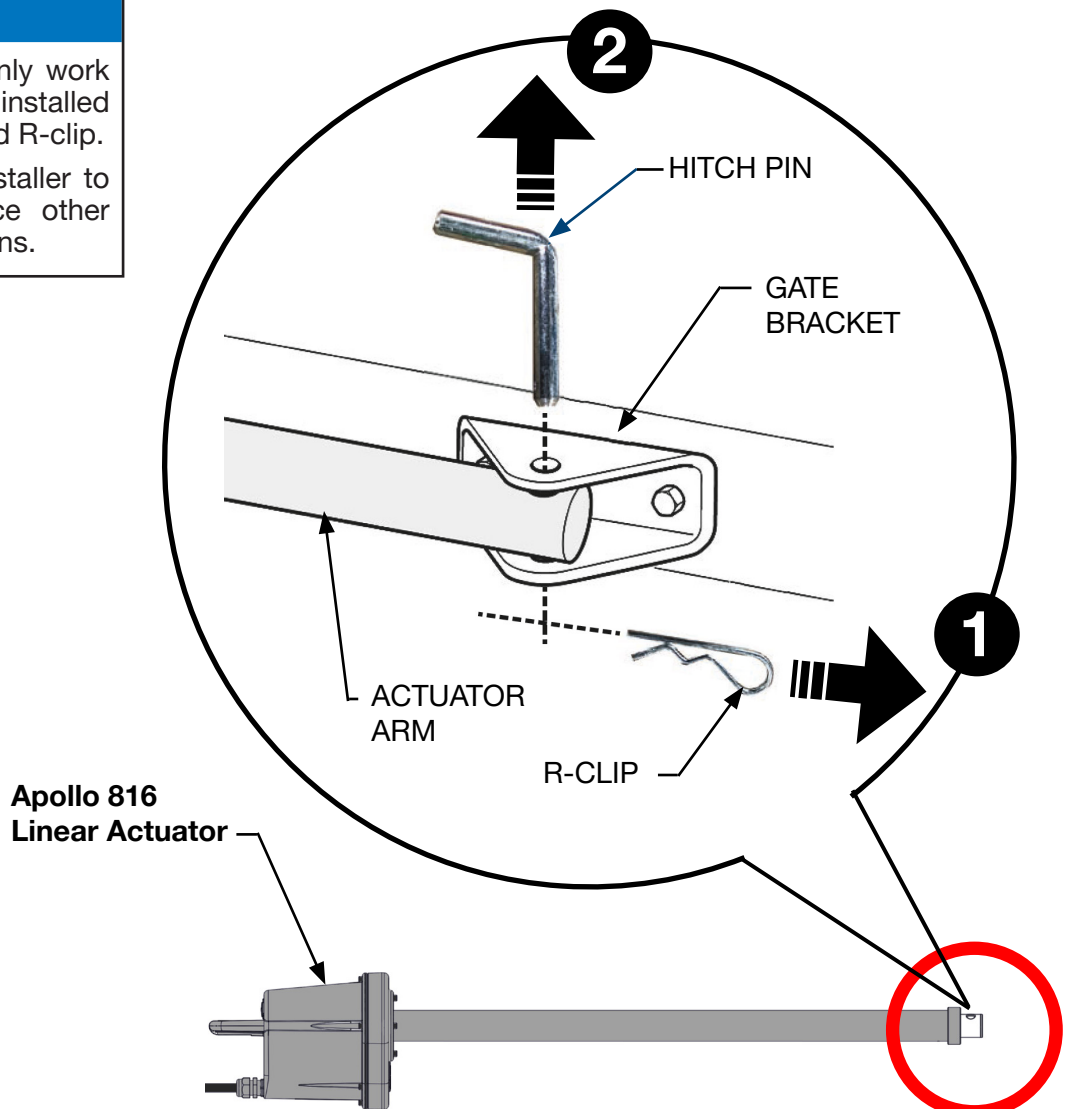

# MERCURY 310 Controller

## User Guide

### 7.2 Titan 912 Linear Actuator

#### Manual Release Instructions: TITAN 916 Linear Actuator

1. Lift up the rubber key cap (See illustration below).
2. Insert key and turn 90° clockwise.
3. Lift up the mechanical release.
4. After mechanical release is opened, the actuator arm can now be freely extended, and the gate can now be moved by hand.
5. To re-enable the actuator, reverse the above instructions.

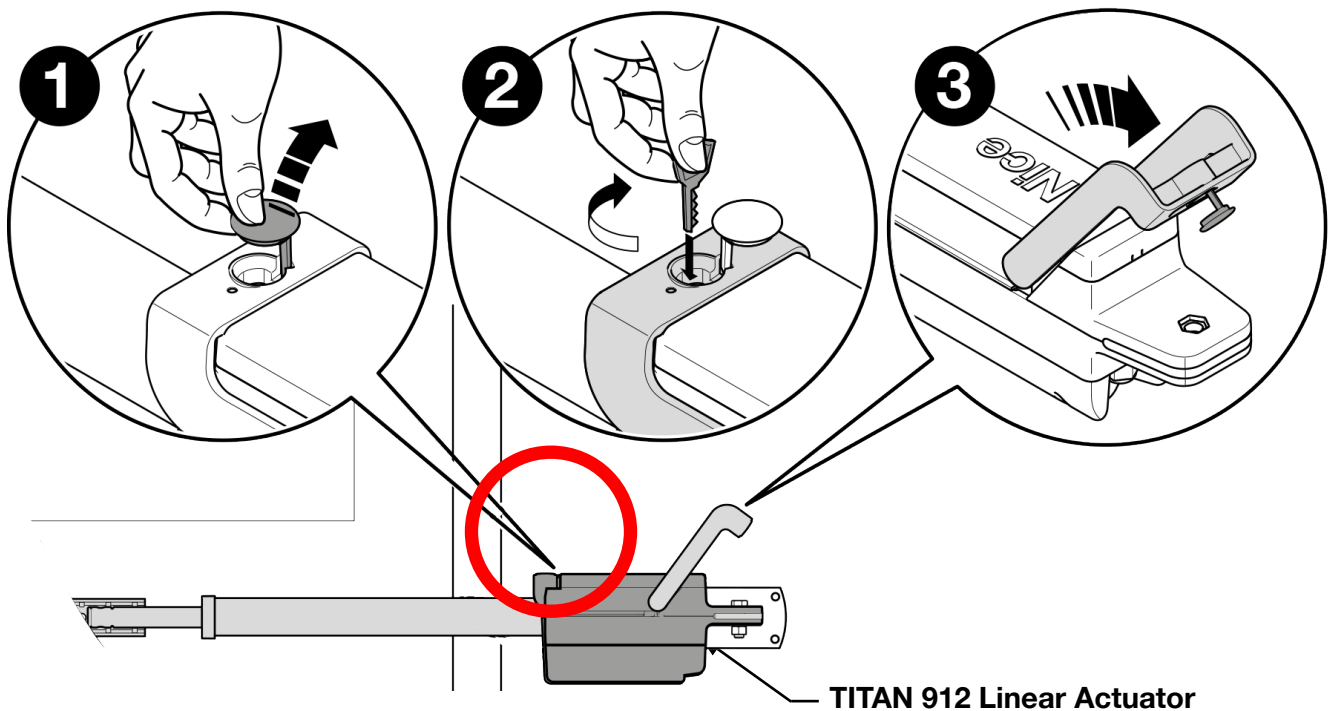

#### **CAUTION**

While it is entirely possible to use the gate system with the TITAN 912 actuator unlocked, it is inadvisable in order to ensure security and safety. Be sure to store the actuator key in a secure place that will be remembered when needed.

# MERCURY 310 Controller

## User Guide

### 8. MAINTENANCE

It is important to ensure that the components of that system are functioning properly. Below are tables indicating maintenance actions for the user and for the gate installer.

User Monthly Maintenance Operations	
Component	Maintenance Action
<b>Gate</b>	Visually inspect gate system for damage, wear, and corrosion.
<b>Gate Travel</b>	Disconnect gate operator and manually move the gate through its range of travel. Note any squeaks from rollers or hinges or areas of binding. Gate should travel smoothly and quietly throughout range. If not, contact a gate professional. Reattach actuator to gate.
<b>Photo Eyes: Open Direction</b>	With the gate opening, block any photo eyes and/or depress any safety edges used to protect the open direction. The gate should stop and/or reverse.
<b>Photo Eyes: Close Direction</b>	With the gate closing, block any photo eyes and/or depress any safety edges used to protect the close direction. The gate should stop and/or reverse.
<b>Inherent Entrapment Systems</b>	<ul style="list-style-type: none"> <li>➔ <b>Open direction:</b> Using a suitable obstruction in the path of the gate (a solid, immovable object), run the gate in the open direction until it contacts the obstruction. The gate should stop and reverse.</li> <li>➔ <b>Close direction:</b> Using a suitable obstruction in the path of the gate (a solid, immovable object), run the gate in the close direction until it contacts the obstruction. The gate should stop and reverse.</li> </ul>

Installer Maintenance Schedule			
Component	Maintenance Action	6 Months	Annually
<b>Alarm</b>	Activation of all devices and systems to test alarm response.	X	X
<b>Backup System</b>	Check operation of gate upon loss of AC power, if connected to mains power.	X	X
<b>Battery</b>	Batteries checked for leakage or loose connections. Battery replacement every two years.	X	X
<b>Fire Dept</b>	Emergency vehicle access device checked for proper operation.	X	X
<b>Loop(S)</b>	If installed, check vehicular reverse and shadow loops for proper operation.	X	X
<b>Release</b>	Check manual release for proper operation.	X	X
<b>Photo Eyes</b>	Activation of all photoeyes by interrupting the photo beam to test gate and alarm responses.	X	X
<b>Gate</b>	Inspect for damage.		X
<b>Hardware</b>	Check screws and nuts for condition and tightness.		X

# MERCURY 310 Controller

## User Guide

DOCUMENT REVISIONS		
NAME	Description of CHANGE	DATE
Curtis Harvey	Rev 3: Mercury 310 user guide.	12/10/2020
Curtis Harvey	Rev A: Final release to production.	07/10/2021
Curtis Harvey	Rev B: Updated sensor list (optex) and P/N on last page.	02/01/2022
Curtis Harvey	Rev C: Updated Failsafe, Batt health, and added Error 20.	05/12/2022
Jeff Farmer	Rev D: Added OXIMGC/A and MTS3 information.	01/15/2026

INSTALLATION INFORMATION AND SIGN-OFFS
<hr/> <p>Installation Acceptance</p>
<hr/> <p>Address where opener is located</p>
<hr/> <p>Installer name, number and address</p>
<hr/> <p>End user name and telephone number</p>



**Customer Service**

760-438-7000  
Monday—Friday, 5:00 a.m. — 4:00 p.m. PST

**Nice North America LLC**

5919 Sea Otter Place, Suite 100  
Carlsbad, CA 92010



**Niceforyou.com**