

1500 LA

816 actuator with
636 control board

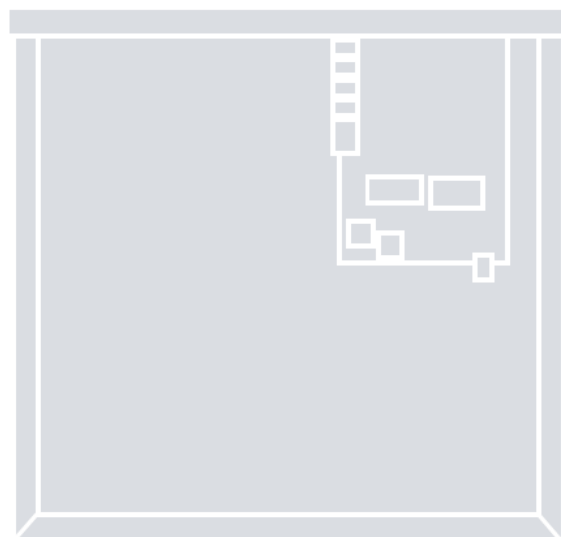

Linear actuator

EN - Installation and programming manual

Nice

1500 LA

Installation and Programming Manual

TABLE OF CONTENTS

SECTION 1: 1500 SYSTEM OVERVIEW	3
1.1 636 CONTROL BOARD FEATURES	3
SECTION 2: 1500 LA PARTS IDENTIFICATION	5
SECTION 3: SAFETY AND UL325 USAGE CLASSES	5
SECTION 4: INSTALLATION SAFETY.....	11
SECTION 5: TOOLS & MATERIALS NEEDED	11
5.1 TOOLS REQUIRED	11
5.2 RECOMMENDED BATTERY SPECIFICATIONS.....	11
SECTION 6: ACTUATOR MECHANICAL INSTALLATION.....	12
SECTION 7: CBOX636 INSTALLATION.....	19
SECTION 8: ACTUATOR WIRING & CONNECTIONS.....	21
8.1 816 ACTUATOR CABLE HARNESS AND BATTERY CONNECTIONS.....	22
SECTION 9: BATTERY CHARGING OPTIONS: AC & Solar	26
9.1 120VAC ELECTRICAL WIRING AND SAFETY	26
9.2 HIGH VOLTAGE WIRE GAUGE REQUIREMENTS	27
9.3 AC-TO-DC CHARGER CONNECTIONS	27
9.4 SOLAR PANEL CONNECTIONS.....	28
9.5 SETTING OPEN/CLOSE LIMITS.....	30
9.6 RECEIVER/TRANSMITTER INSTALLATION & PROGRAMMING.....	32
SECTION 10: 636 CONTROL BOARD FEATURES	36
10.1 EMERGENCY BYPASS CONNECTOR.....	36
10.2 636 CONTROL BOARD CONTROLS, SWITCHES, & FUSES.....	37
10.3 DIP SWITCH SETTINGS	38
10.4 ACCESSORY CONNECTORS	39
SECTION 11: APPENDIX	40
11.1 CALCULATING SOLAR REQUIREMENTS.....	40
11.2 MAINTENANCE SCHEDULE	41
11.3 SYSTEM TROUBLESHOOTING	42
11.4 INSTALLATION CHECKLIST	43
11.5 PART DRAWINGS	44
SECTION 12: WARRANTY	49

1500 LA

Installation and Programming Manual

SECTION 1: 1500 SYSTEM OVERVIEW

Congratulations on selecting a Nice 1500 LA Series gate operator using the 636 control board and 816 LA actuator. With proper selection, system design, installation and maintenance this operator should provide years of reliable operation.

EXTREMELY IMPORTANT!

Anyone who installs, assists with installation or otherwise facilitates the installation in any manner should thoroughly read and understand this manual in its entirety before any attempt is made to actually begin the installation process.

1.1 636 CONTROL BOARD FEATURES

The 636 control board offers the following features:

- Simple installation and configuration
- Dual gate capable
- Low power consumption for longer battery life in solar configurations
- Voltage output (+12VDC) connectors to power various added accessories
- Emergency bypass connector
- Settings for timer to close, sensitivity, gate reversal after timeout, close timer, and open, stop, close controls
- LEDs for configuration and troubleshooting
- Accepts standalone receiver for remote control operation

1500 LA Installation and Programming Manual

CBOX636 SPECIFICATIONS

OPERATOR KIT	Single Gate: CBOX636 and 816-1 Dual Gate: CBOX636, 816-1, and 816-2
OPERATING VOLTAGE	12 VDC
STANDBY CURRENT	10 mA
ACCESSORY POWER	12 VDC
POWER SOURCES	12VDC battery (and optional solar panel for charging)
OPEN/CLOSE TIME (TO 90°)	14 - 16 (gate dependant)
TEMPERATURE RATING	-4° to 122° F (-20° to 50° C)
GATE WEIGHT MAXIMUM	600 lbs. (272 kg)
GATE LENGTH MAXIMUM	16 feet (5 meters)
USER CONTROLS	636 control board
CONTROL BOX DIMENSIONS (inches)	18x18x8
ACCESSORY INPUTS	3x Step-by-Step Inputs, 2x Edge Sensor, Shadow, Safety, Fee Exit, Emergency Bypass
REMOTE CONTROL	Nice 1-channel 318MHz MegaCode receiver

816 LA ACTUATOR SPECIFICATIONS

DRIVE	Electromechanical
GATE LENGTH MAX.	16 ft (5 m) leaf
GATE WEIGHT MAX	600 lb (272 kg)
OPEN/CLOSE TIME (TO 90°)	14 - 16 seconds (adjustable)
TEMPERATURE RATING	-4° to 122° F (-20° to 50° C)
OPERATING VOLTAGE	12VDC
ACTUATOR DIMENSIONS	42" retracted - 66" extended
USER CONTROLS	636, 936, or 1050 control board
LISTED TO UL325	936 & 1050 Control Boards: Usage Class I, II,

816 LA ACTUATOR PARTS LIST

PART#	DESCRIPTION	QTY
816-1	ACTUATOR WITH 12 FOOT HARNESS	1
816-2 (DUAL GATE ONLY)	ACTUATOR WITH 42 FOOT HARNESS	1
1116	PIVOT ARM	1
10025215	GATE BRACKET	1
1125	ACTUATOR BOLT KIT	1

- 816-1 - ACTUATOR WITH 12' HARNESS
- 816-2 - ACTUATOR WITH 42' HARNESS

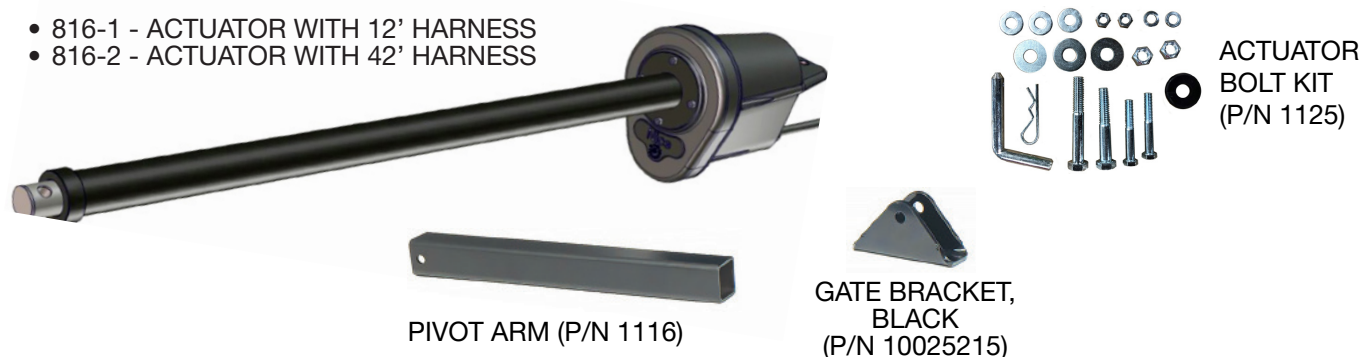

1500 LA Installation and Programming Manual

SECTION 2: 1500 LA PARTS IDENTIFICATION

1500 LA PARTS LIST		
PART#	DESCRIPTION	QTY
CBOX636	1500 Series Control Box with 636 Control Board	1
MGR	1-Channel MegaCode gate receiver	1
ABF/A	Antenna for 318N Receiver	1
273C	Gate Warning Signs	2
75500019	Cable Ties (for Warning Signs)	4



GATE OPERATOR CONTROL BOX
(P/N CBOX636)



1-CHANNEL RECEIVER
(P/N MGR)



RECEIVER ANTENNA
(P/N ABF/A)



WARNING SIGNS
(P/N 273C)



CABLE TIES (P/N 75500019)
(FOR WARNING SIGNS)

SECTION 3: SAFETY AND UL325 USAGE CLASSES

The UL325 standard covers gate operators. Within this safety standard several Usage Classes are described that define different types of installations where gate operators can be applied. Some operators are restricted in their usage application. All Nice USA operators are approved for use in all four UL325 Usage Classes. Appropriate Usage Classes are shown in the specifications.

CLASS I RESIDENTIAL GATE OPERATOR

Intended for use in a location of one to four single family dwellings or a parking area associated with one to four single family dwellings.



CLASS III INDUSTRIAL/LIMITED ACCESS GATE OPERATOR

Intended for use in an industrial location or building such as factories or loading docks or other locations not intended to service general public.



CLASS II COMMERCIAL/GENERAL ACCESS GATE OPERATOR

Intended for use in a commercial location or building such as a multi-family housing units (five or more single family units) hotels, garages, retail stores or other buildings servicing general public.



CLASS IV RESTRICTED ACCESS GATE OPERATOR

Intended for use in guarded industrial locations or buildings such as an airport security area or other restricted access location, not servicing general public, in which access is monitored by security personnel or via closed circuitry.



1500 LA

Installation and Programming Manual

IMPORTANT!

- The gate operator installation is NOT a “do-it-yourself” project. Contract a qualified gate operator installation company to install this system to ensure a safe and reliable installation.
- It is the responsibility of the property owner to ensure the installer is qualified to carry out the installation in a safe and professional manner.
- Consult local government agencies for latest rules and regulations to satisfy licensing, codes or regulations for automated gate system design and installation.

SAFETY, WARNINGS, AND CAUTIONS

A gate operator is only a component in a gate system. The other parts of the gate system can include:

- the gate
- the external entrapment sensors
- access controls
- vehicle detectors

To have a gate system that provides safety, security, and reliable operation it is essential these components operate together as a system. It is the responsibility of the system designer and/or installer to ensure any safety or operational issues have been addressed.



DANGER!

TO REDUCE THE RISK OF SEVERE INJURY, DEATH, OR PROPERTY DAMAGE READ AND FOLLOW ALL SAFETY INSTRUCTIONS. SAVE THESE INSTRUCTIONS!

- Never let children operate or play with gate controls. Keep the remote control away from children.
- Always keep people and objects away from the gate. No one should cross the path of the moving gate.
- Test the gate operator monthly. Gate must reverse on contact with a rigid object or stop when an object activates the non-contact sensors. After adjusting the force or the limit of travel, retest the gate operator. Failure to adjust and retest the gate operator properly can increase the risk of injury or death.
- Use the emergency release only when gate is not moving.
- Keep gates properly maintained. Read the user’s manual. Have a qualified service person make repairs to gate hardware.
- The entrance is for vehicles only. Pedestrians must use separate entrance.
- Save these instructions.

UL325 USAGE CLASSES

The UL325 standard covers gate operators. Within this safety standard several Usage Classes are described that define different types of installations where gate operators can be applied. Some operators are restricted in their usage application. All Nice USA operators are approved for use in all four UL325 Usage Classes. Appropriate Usage Classes are shown in the Specifications.

CLASS I RESIDENTIAL GATE OPERATOR: Intended for use in a location of one to four single family dwellings or a parking area associated with one to four single family dwellings.

CLASS II COMMERCIAL/GENERAL ACCESS GATE OPERATOR: Intended for use in a commercial location or building such as a multi-family housing units (five or more single family units) hotels, garages, retail stores or other buildings servicing general public.

CLASS III INDUSTRIAL/LIMITED ACCESS GATE OPERATOR: Intended for use in an industrial location or building such as factories or loading docks or other locations not intended to service general public.

CLASS IV RESTRICTED ACCESS GATE OPERATOR: Intended for use in guarded industrial locations or buildings such as an airport security area or other restricted access location, not servicing general public, in which access is monitored by security personnel or via closed circuitry.

VEHICULAR TRAFFIC ONLY

This automatic gate operator is not designed nor is it intended for pedestrian traffic. Vehicular gate operators must by their nature be powerful to function reliably. This power can cause injury or death. Accordingly, direct all pedestrian traffic to a separate walk-through gate.

GATE INSTALLATION REQUIREMENTS

Install this gate operator only when:

- The operator is appropriate for the construction of the gate and the usage Class of the gate;
- All openings of a horizontal slide gate are guarded or screened from the bottom of the gate to a minimum of 1.83 meters (6 feet) above the ground to prevent a 57.2 mm (2-1/4 inches) diameter sphere from passing through the openings anywhere in the gate, and the portion of the adjacent fence that the gate covers in the open position.
- All exposed pinch points are eliminated or guarded.
- Guarding is supplied for exposed rollers).

1500 LA

Installation and Programming Manual

PEDESTRIAN TRAFFIC

The operator is intended for installation only on gates used for vehicles. Pedestrians must be supplied with a separate access opening. The pedestrian access opening shall be designed to promote pedestrian usage. Locate the gate such that persons will not come in contact with the vehicular gate during the entire path of travel of the vehicular gate.

GATE CLEARANCES

The gate must be installed in a location so that enough clearance is supplied between the gate and adjacent structures when opening and closing to reduce entrapment risk. Swinging gates shall not open into public access areas.

GATE CONDITION

The gate must be properly installed and work freely in both directions prior to gate operator installation. Don't change operator force sensitivity settings to compensate for an improperly installed, improperly functioning, or damaged gate.

GATE CONTROL ACCESS

Permanently mounted controls intended for user activation must be located at least 1.83 m (6 ft) away from any moving part of the gate and where the user is prevented from reaching over, under, around or through the gate to operate the controls. Exception: Emergency access controls only accessible by authorized personnel (e.g. fire, police, EMS) may be placed at any location in the line-of-sight of the gate.

STOP/START BUTTON LOCATION

The Stop and/or Reset button must be located in the line-of-sight of the gate. Activation of the reset control shall not cause the operator to start.

WARNING SIGNS

A minimum of two (2) WARNING SIGNS shall be installed, in the area of the gate. Each placard is to be visible by persons located on the side of the gate on which the placard is installed.

PHOTO EYE SENSORS

For gate operators using a non-contact sensor (Photo Eye):

- See instructions on the placement of non-contact sensors for each type of application.
- Care shall be exercised to reduce the risk of nuisance tripping, such as when a vehicle, trips the sensor while the gate is still moving, and...
- One or more non-contact sensors shall be located where the risk of entrapment or obstruction exists, such as the perimeter reachable by a moving gate or barrier.

CONTACT SENSORS (EDGE)

For a gate operator utilizing a contact sensor (Edge):

- One or more contact sensors shall be located where entrapment or obstruction risks exists, such as at the leading edge, trailing edge, and post-mounted both inside and outside of a vehicular horizontal slide gate.
- A hardwired contact sensor shall be located and its wiring arranged so that the communication between the sensor and the gate operator is not subjected to mechanical damage.
- A wireless device such as one that transmits radio frequency (RF) signals to the gate operator for entrapment protection functions shall be located where the transmission of the signals are not obstructed or impeded by building structures, natural landscaping or similar obstruction. A wireless device shall function under the intended end-use conditions.
- One or more contact sensors shall be located on the inside and outside leading edge of a swing gate. Additionally, if the bottom edge of a swing gate is greater than 152 mm (6 in) but less than 406 mm (16 in) above the ground at any point in its arc of travel, one or more contact sensors shall be located on the bottom edge.

USE OF VEHICLE DETECTORS

Use of vehicle detectors (loop detectors) is strongly encouraged to prevent damage to vehicles caused by gates closing on them. This is not considered to be a safety item as vehicle detectors cannot provide protection to pedestrians. In some situations, photoelectric devices may be used as vehicle detectors, but should be wired accordingly.

GATE CONSTRUCTION & SAFETY

Gate construction plays a very important role in ensuring the safety of any automated gate system. The standard for gate construction is ASTM F2200. Below are key areas to address safety in gate design. For complete information consult the standard. Copies of the standard are available at:

<https://www.astm.org/Standards/F2200.htm>

Another source of information is available from DASMA, the Door and Access System Manufacturer's Association. The Association publishes Technical Data Sheets, one of which concerns ASTM F2200. For more information, see:

<http://www.dasma.com/PDF/Publications/TechDataSheets/OperatorElectronics/TDS370.pdf>

1500 LA

Installation and Programming Manual

GENERAL GATE CONSTRUCTION REQUIREMENTS:

GATE TYPES

Gates shall be constructed in accordance with the provisions given for the appropriate gate type listed. Refer to ASTM F2200 for additional gate types.

DETACHED GATES

Gates shall be designed, constructed and installed to not fall over more than 45 degrees from the vertical plane, when a gate is detached from the supporting hardware.

GATE BOTTOM EDGE

Gates shall have smooth bottom edges, with vertical bottom edged protrusions not exceeding 0.50 inch (12.7 mm) when other than the exceptions listed ASTM F2200.

BARBED WIRE/TAPE HEIGHT

The minimum height for barbed wire shall not be less than 6 ft. (1.83 m) above grade. The minimum height for barbed tape shall not be less than 8 ft. (2.44 m) above grade.

EXISTING GATE LATCHES

An existing gate latch shall be disabled when a manually operated gate is retrofitted

GATE LATCH RESTRICTIONS

A gate latch shall not be installed on an automatically operated gate.

GATE PROTRUSIONS

Protrusions shall not be permitted on any gate. Consult ASTM F2200 for exceptions.

GRAVITY AND GATE MOVEMENT

Gates shall be designed, constructed and installed such that their movement shall not be initiated by gravity when an automatic operator is disconnected.

PEDESTRIAN GATES

For pedestrian access in the vicinity of an automated vehicular gate, a separate pedestrian gate shall be provided. The pedestrian gate shall be installed in a location such that a pedestrian shall not come in contact with a moving vehicular access gate. A pedestrian gate shall not be incorporated into an automated vehicular gate panel.

UPGRADING NON-AUTOMATIC GATES

Any non-automated gate that is to be automated shall be upgraded to conform to the provisions of this specification.

PEDESTRIAN AND NON-AUTOMATIC GATES

This specification shall not apply to gates generally used for pedestrian access and to vehicular gates not to be automated.

UPGRADING EXISTING AUTOMATED GATES

Any existing automated gate, when the operator requires replacement, shall be upgraded to conform to the provisions of this specification in effect at that time.

VEHICULAR HORIZONTAL SLIDE GATE REQUIREMENTS:

CLASS I, II AND III VEHICULAR HORIZONTAL SLIDE GATES:

The following provisions shall apply to Class I, Class II and Class III vehicular horizontal slide gates:

Exposed Rollers

All weight bearing exposed rollers 8 feet (2.44 m), or less, above grade shall be guarded or covered

Guarding or Screening Gate Openings

All openings shall be designed, guarded, or screened from the bottom of the gate to the top of the gate or a minimum of 72 inch (1.83 m) above grade, whichever is less, to prevent a 2 1/4 inch (57 mm) diameter sphere from passing through the openings anywhere in the gate, and in that portion of the adjacent fence that the gate covers in the open position. The gate panel shall include the entire section of the moving gate, including any back frame or counterbalance portion of the gate.

Gaps Between Gate Frames and Other Objects

A gap, measured in the horizontal plane parallel to the roadway, between a fixed stationary object nearest the roadway (such as a gate support post) and the gate frame when the gate is in either the fully open position or the fully closed position, shall not exceed 2 1/4 inch (57 mm). Exception: All other fixed stationary objects greater than 16 inch (406 mm) from the gate frame shall not be required to comply with this section.

Class I, Class II and Class III Gate Stops

Positive stops shall be required to limit travel to the designed fully open and fully closed positions. These stops shall be installed at either the top of the gate, or at the bottom of the gate where such stops shall horizontally or vertically project no more than is required to perform their intended function.

Gate Lateral Stability

All gates shall be designed with sufficient lateral stability to assure that the gate will enter a receiver guide. Consult ASTM F2200 for details on various gate panel types.

CLASS IV VEHICULAR HORIZONTAL SLIDE GATES:

The following provisions shall apply to Class IV vehicular horizontal slide gates:

Guarded or Covered Rollers

All weight bearing exposed rollers 8 feet (2.44 m), or less, above grade shall be guarded or covered.

1500 LA

Installation and Programming Manual

Class IV Gate Stops

Positive stops shall be required to limit travel to the designed fully open and fully closed positions. These stops shall be installed at either the top of the gate, or at the bottom of the gate where such stops shall horizontally or vertically project no more than is required to perform their intended function.

CLASS I, II, AND III HORIZONTAL SWING GATES:

The following provisions shall apply to Class I, Class II, and Class III horizontal swing gates:

Avoiding Entrapment Areas

Gates shall be designed, constructed and installed so as not to create an entrapment area between the gate and the supporting structure or other fixed object when the gate moves toward the fully open position, subject to the following provisions.

Open Gate Size Restrictions

The width of an object (such as a wall, pillar or column) covered by a swing gate when in the open position shall not exceed 4 inch (102 mm), measured from the centerline of the pivot point of the gate. Exception: For a gate that is not in compliance with this provision, the defined area shall be subject to the entrapment protection provisions of UL 325.

Open Gate Minimum Distance to Objects

Except for the zone specified in Open Gate Size Restriction (above) the distance between a fixed object such as a wall, pillar or column, and a swing gate when in the open position shall not be less than 16 inch (406 mm). Exception: For a gate that is not in compliance with this provision, the defined area shall be subject to the entrapment protection provisions of UL 325.

Class IV Installations

Class IV vehicular horizontal swing gates shall be designed, constructed and installed in accordance with security related parameters specific to the application in question.

MAINTENANCE OF GATE SYSTEMS

To keep your automated gate system performing both safely and reliably it is important to ensure that the components of that system are functioning properly. At least monthly:

GATE TRAVEL TESTING

Disconnect the gate operator and manually move the gate through its range of travel. Note any squeaks from rollers or hinges or areas of binding. The gate should travel smoothly and quietly throughout its range. If it does not, contact a gate professional to correct the problem.

SAFETY DEVICE TESTING

Reconnect gate operator and perform the following tests:

PHOTO EYE BLOCKAGE TEST

With the gate opening, block any photo eyes and/or depress any safety edges used to protect the open direction. The gate should stop, or, stop and reverse.

EDGE CONTACT TEST

With the gate closing, block any photo eyes and/or depress any safety edges used to protect the close direction. The gate should stop, or, stop and reverse.

OBSTRUCTION TEST - OPENING

Using a suitable obstruction in the path of the gate (a solid, immovable object), run the gate in the open direction until it contacts the obstruction. The gate should stop and reverse.

ENTRAPMENT PROTECTION

The UL325 standard for gate operators requires a minimum of two independent entrapment protection means for each entrapment zone. An entrapment zone is defined as follows: For slide gates, any locations between a moving gate and a counter opposing edge or surface where entrapment is possible up to a height of 6 ft. (1.83 m) above grade. Such locations occur if at any point in travel if the gap between a moving gate and the fixed counter opposing edges or surfaces is less than 16 inch (406 mm).

For swing gates, locations between a moving gate or moving, exposed operator components and a counter opposing edge or surface where entrapment is possible up to 6 feet (1.83m) above grade. Such locations occur if during any point in travel:

- a. The gap between the bottom of a moving gate and the ground is greater than 4 inch (101.6 mm) and less than 16 inch (406 mm); or
- b. The distance between the center line of the pivot and the end of the wall, pillar, or column to which it is mounted when in the open or closed position exceeds 4 inch (101.6 mm). Any other gap between a moving gate and fixed counter opposing edges or surfaces or other fixed objects is less than 16 inch (406 mm) (examples are walls, curbs, berms or other immovable objects).
- c. Potential entrapment zones may be identified before installation for swing gates, but there may be other entrapment zones presented by the actual installation and adjacent structures or landscape that must be protected as well. All Nice gate operators feature an Inherent Entrapment System (IES) (UL325 Type A) that monitors the force on the gate during travel. This system protects in both the open and close direction and reverses on contact with an obstruction. This IES system serves as one of the means of entrapment protection.

1500 LA

Installation and Programming Manual

External sensors must be used to protect against entrapment at each location where an entrapment zone exists. The minimum number of external sensors required to enable automatic operation of the swing gate is one sensor in the close direction (provided the gate in the open direction presents no risk of entrapment.)

The gate operator tests for the presence of at least one functioning sensor, and if not found, the operator will only run using continuous pressure on an Open/Close button, either on the controller, or an external device.

SENSORS AND ACCESSORIES

Instructions have been provided for installation of the photo eye transmitter/receiver pair per UL325 requirements, but there are other sensors that should be used to avoid entrapment scenarios.

- Non-contact and contact sensors must be installed individually or in combination with each other to provide external entrapment protection.
- Care should be exercised to reduce the risk of nuisance tripping, such as when a vehicle trips the sensor while the gate is still moving, and one or more non-contact sensors shall be located where the risk of entrapment or obstruction exists, such as the perimeter reachable by a moving gate or barrier.
- A hardwired contact sensor shall be located and its wiring arranged so that the communication between the sensor and the gate operator is not subjected to mechanical damage.
- A wireless contact sensor such as one that transmits radio frequency (RF) signals to the gate operator for entrapment protection functions shall be located where the transmission of the signals are not obstructed or impeded by building structures, natural landscaping or similar obstruction.

1500 LA Installation and Programming Manual

SECTION 4: INSTALLATION SAFETY

IMPORTANT!

- The gate operator installation is NOT a “do-it-yourself” project. Contract a qualified gate operator installation company to install this system to ensure a safe and reliable installation.
- Property owner is responsible to ensure installer is qualified to make a safe and professional installation.
- Consult local government agencies for up-to-date rules and regulations to satisfy licensing, codes or regulations that regulate automated gate system design and installation.
- The gate being modified should be level and plumb and the gate should open easily and evenly.
- Nice swing gate systems are NOT intended for installation on an incline.



CAUTION!

- Disconnect power at the control panel before making any electric service power connections.
- Be aware of all moving parts and avoid close proximity to any pinch points.

SECTION 5: TOOLS & MATERIALS NEEDED

5.1 TOOLS REQUIRED

Below is a list of tools and materials necessary for installation of the actuator and control box:

- Welder, unless optional bolt-on pivot arm (P/N 446) is used.
- Basic hand tools (screwdrivers, wrenches, pliers, etc..)
- Bubble Level (for ensuring pivot arm and actuator are level).
- Framing square (for determining pivot arm location)
- Wire cutters/strippers
- Drill and assorted size bits
- Hardware for mounting control box
- Electrical conduits, grommets, asphalt patch, etc. as needed

5.2 RECOMMENDED BATTERY SPECIFICATIONS

The following are required to install and program the CBOX636:

- 12VDC battery to power the control board
- An AC-to-DC fully automatic charger and/or solar panel to charge the battery.

Nice offers AC-to-DC converters and solar panel solutions for charging 12VDC batteries. Recommended battery specifications are as follows:

RECOMMENDED 12VDC BATTERY SPECIFICATIONS
12 Volt DC Output
Sealed lead acid starter battery
Terminal posts on top (not sides)
35 AMP hours or larger for AC charging applications
70 AMP hours or larger for Solar charging applications & Longer Backup

1500 LA Installation and Programming Manual

SECTION 6: ACTUATOR MECHANICAL INSTALLATION

1A INSTALL PIVOT ARM TO GATE: PULL-TO-OPEN

1. Securely mount the pivot arm to the hinge post (IMAGE 1A-1).
2. If necessary, cut pivot arm for correct placement of the actuator mounting hole. Measurements are taken from the center of pivot of the gate hinge.
3. It is strongly recommended to weld the pivot arm to the hinge post.

NOTE: Welding is much preferred but Nice offers an optional bolt-on pivot arm (P/N 446) for when welding is not possible.



CAUTION!

NEVER WELD PARTS TO THE GATE OR POSTS WHEN THE CONTROL BOARD IS POWERED TO AVOID IRREPAIRABLE DAMAGE TO THE CIRCUIT BOARD!

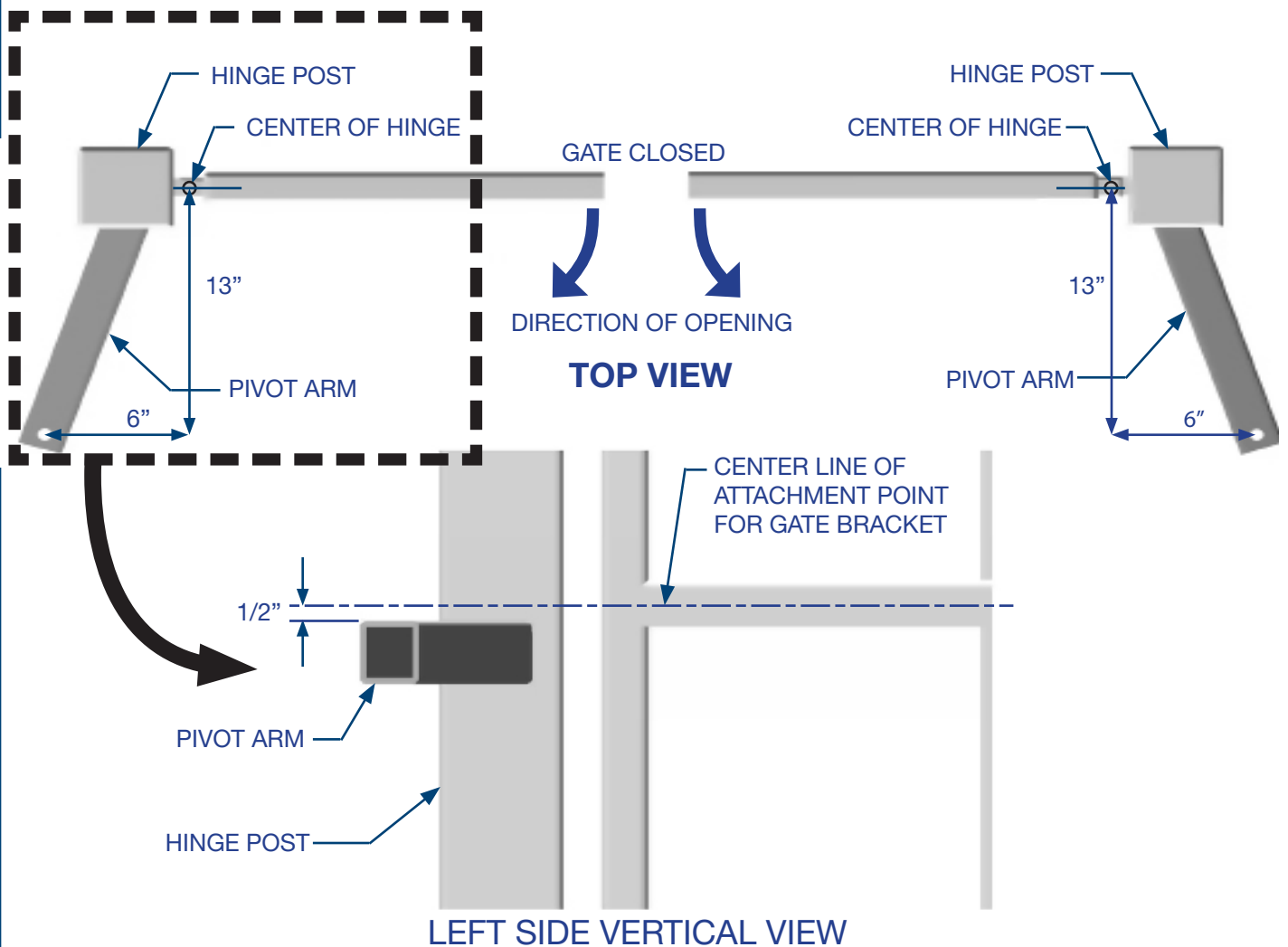

IMAGE 1A-1: "PULL TO OPEN" PIVOT ARM INSTALLATION

1500 LA Installation and Programming Manual

1B INSTALL PIVOT ARM TO GATE: PUSH-TO-OPEN

1. Securely mount the pivot arm to the hinge post (IMAGE 1B-1).
2. If necessary, cut pivot arm for correct placement of the actuator mounting hole. Measurements are taken from the center of pivot of the gate hinge.
3. It is strongly recommended to weld the pivot arm to the hinge post.

NOTE: Welding is much preferred but Nice offers an optional bolt-on pivot arm (P/N 446) for when welding is not possible.



CAUTION!

NEVER WELD PARTS TO THE GATE OR POSTS WHEN THE CONTROL BOARD IS POWERED TO AVOID IRREPAIRABLE DAMAGE TO THE CIRCUIT BOARD!

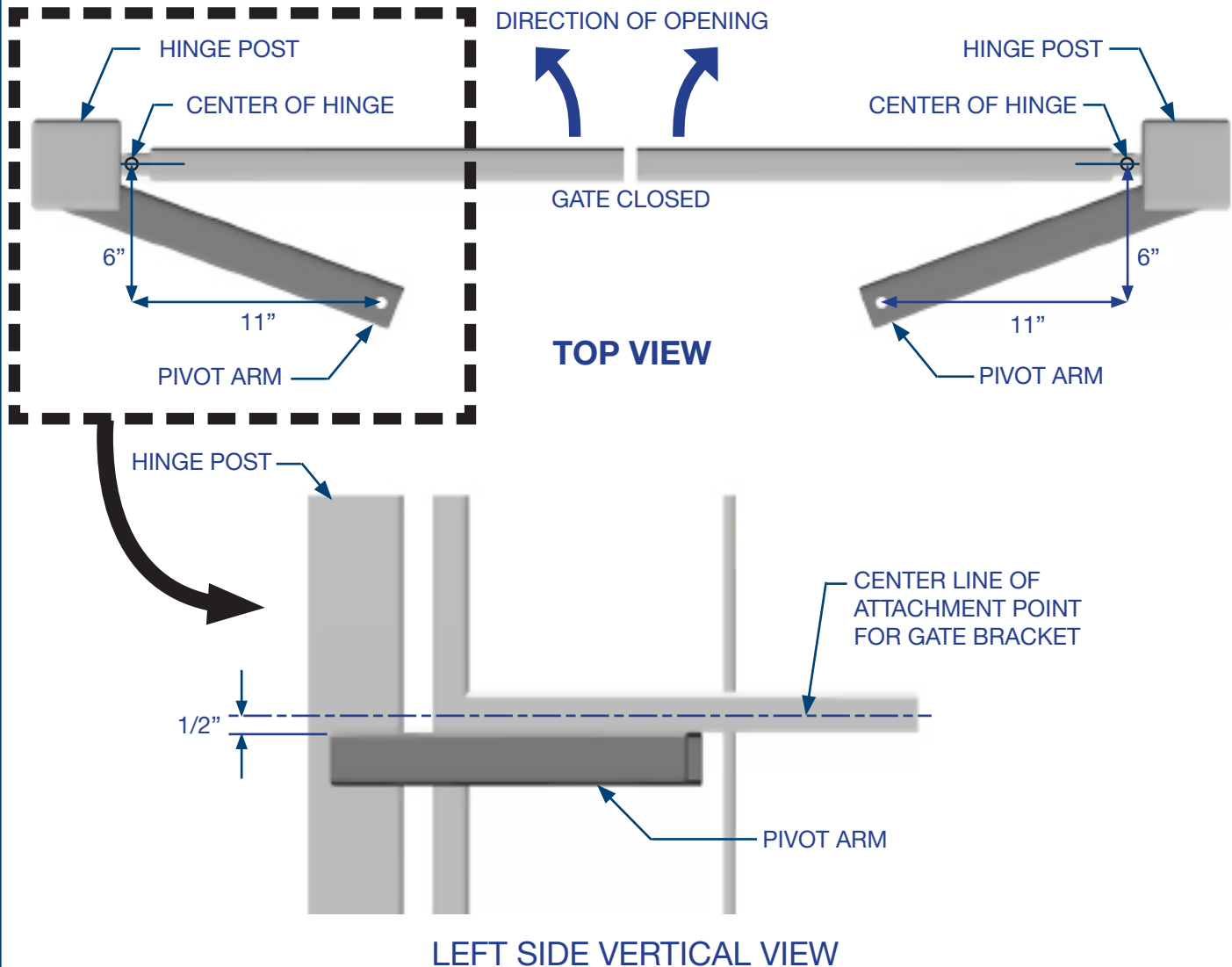

IMAGE 1B-1: "PUSH TO OPEN" PIVOT ARM INSTALLATION

1500 LA Installation and Programming Manual

2

MOUNT ACTUATOR TO PIVOT ARM

1. Mount the actuator to the pivot arm as shown (IMAGE 2-1). Note that the washer goes above the actuator flange.
2. Tighten the lock nut to prevent movement or shifting when the actuator is running. This will also prevent excessive “bounce” or “wobble” when the gate stops moving.

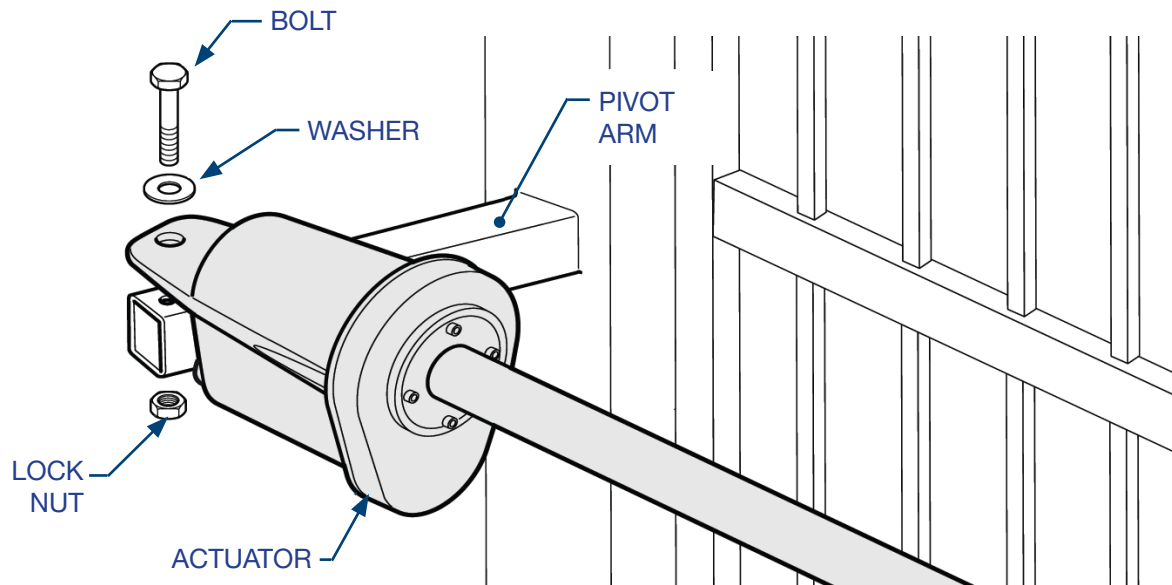

IMAGE 2-1: ACTUATOR INSTALLATION

1500 LA Installation and Programming Manual

3

AFFIX GATE BRACKET TO ACTUATOR ARM

If security is of the utmost importance then the bracket may be connected to the actuator arm using the 1/2" x 3" bolt, washer, and lock nut (IMAGE 3-1).

However, to enable quick manual opening of the gate in case of power failure, it is recommended to use the quick release hitch pin with R-clip (IMAGE 3-2).

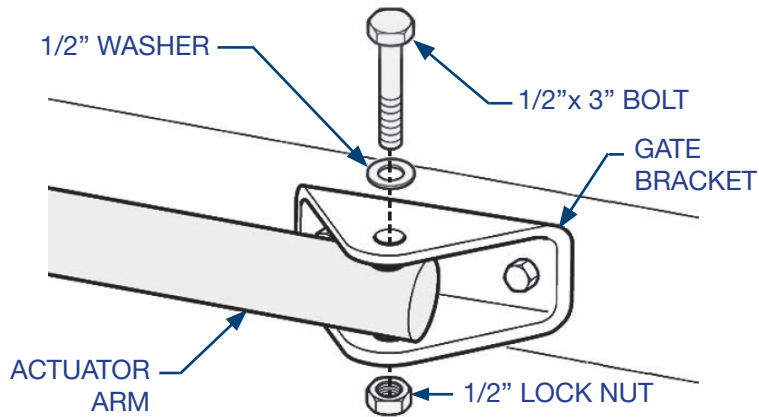

IMAGE 3-1: GATE BRACKET TO ACTUATOR USING BOLT, WASHER, & NUT

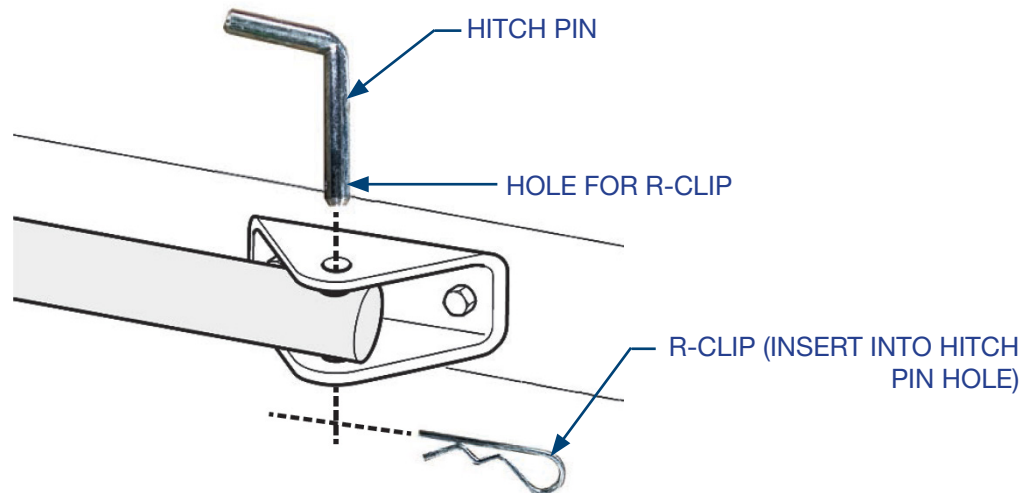

IMAGE 3-2: GATE BRACKET TO ACTUATOR USING HITCH PIN AND R-CLIP

1500 LA Installation and Programming Manual

3: AFFIX GATE BRACKET TO ACTUATOR ARM (CONT.)

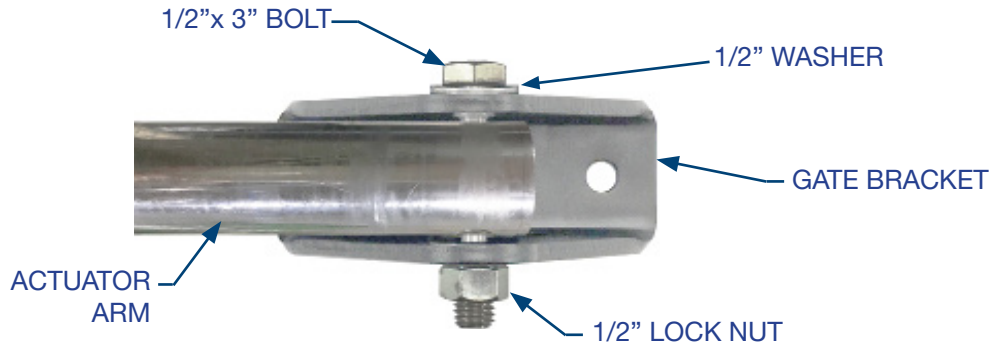

IMAGE 3-3: GATE BRACKET WITH BOLT, WASHER, NUT

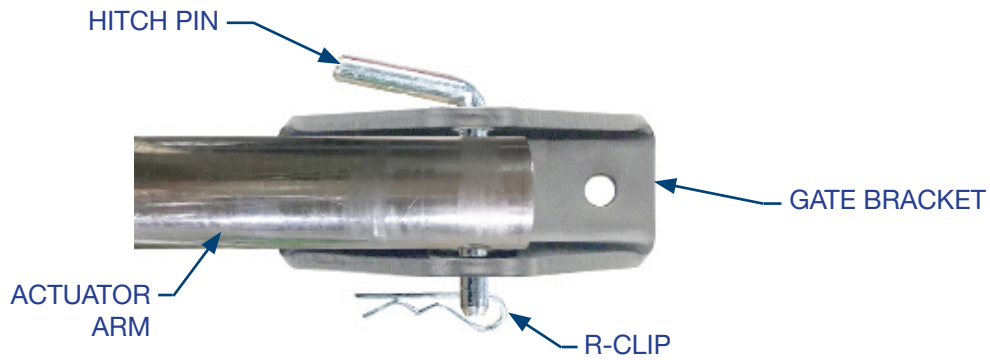

IMAGE 3-4: GATE BRACKET WITH HITCH PIN AND R-CLIP

1500 LA Installation and Programming Manual

4

POSITION GATE BRACKET ON GATE

1. Place gate in:
 - a) OPEN position for PULL-TO-OPEN configuration (IMAGE 4-1).
 - b) CLOSED position for PUSH-TO-OPEN configurations (IMAGE 4-2).
2. With actuator arm fully retracted, rotate entire actuator on the pivot arm around until the gate bracket attached to the actuator is positioned on a supporting structure of gate.
3. Mark position of gate bracket on gate or clamp into position.

NOTES:

- Do not attach gate bracket to gate pickets. Attach only to structural supports.
- If unsure of exact bracket location, tack weld or clamp until gate can be tested.

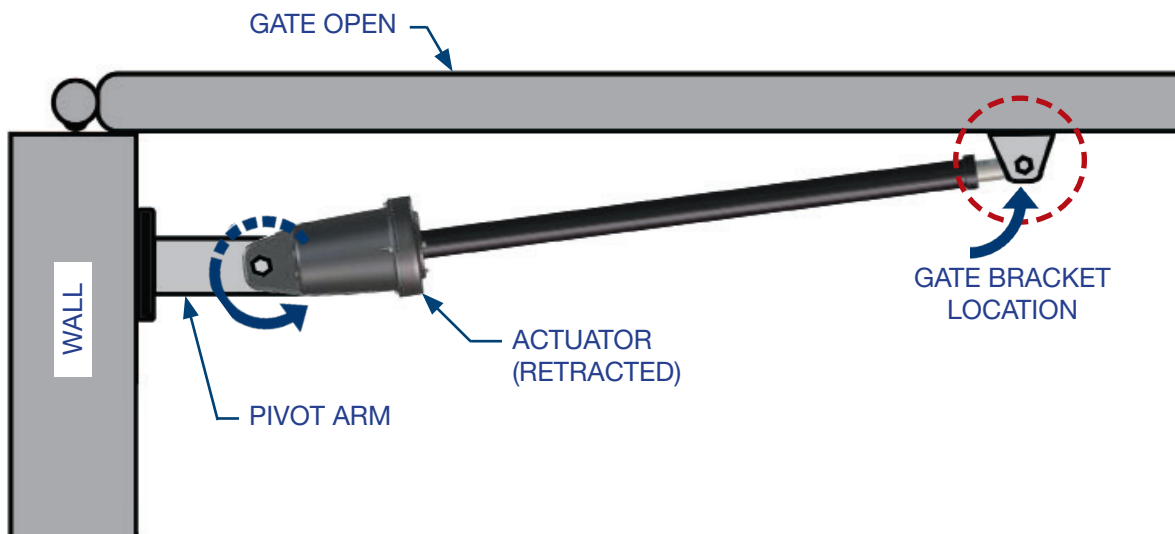

IMAGE 4-1: GATE BRACKET LOCATION (PULL-TO-OPEN)

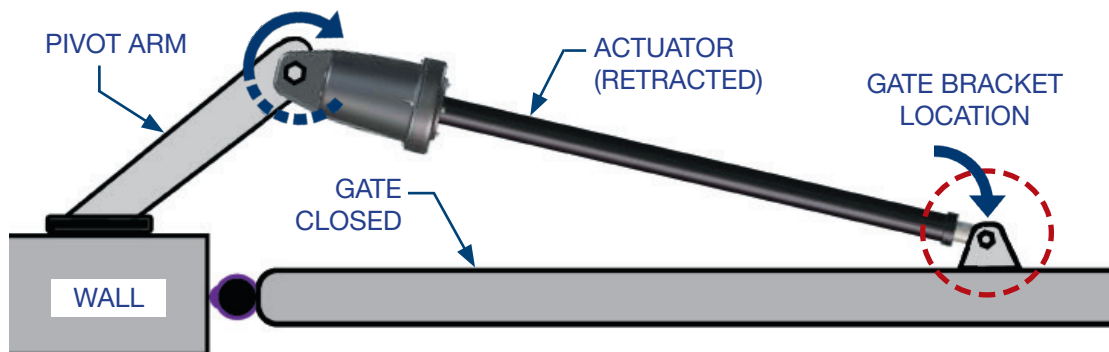

IMAGE 4-2: GATE BRACKET LOCATION (PUSH-TO-OPEN)

1500 LA Installation and Programming Manual

5 AFFIX GATE BRACKET TO GATE

1. Weld the gate bracket to the gate supporting structure (IMAGE 5-1).



CAUTION!

NEVER WELD PARTS TO THE GATE OR POSTS WHEN THE CONTROL BOARD IS POWERED TO AVOID IRREPAIRABLE DAMAGE TO THE CIRCUIT BOARD!

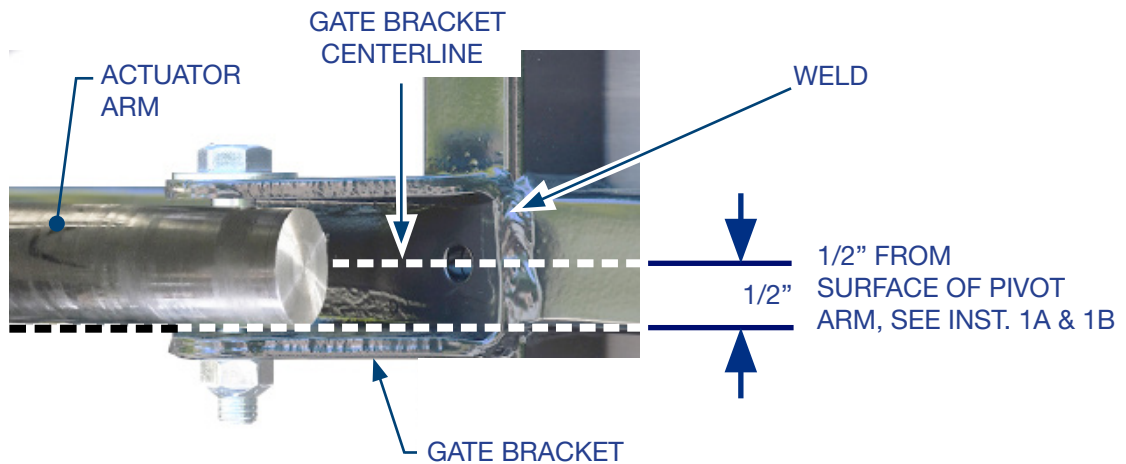

IMAGE 5-1: GATE BRACKET WELDED TO GATE

IMPORTANT! Ensure bracket centerline is 1/2" above the top of the pivot arm.

2. If welding is not possible, drill two holes to match bracket and affix with two 3/8"x2.5" screws and 3/8" nuts included in the kit (IMAGE 5-2).

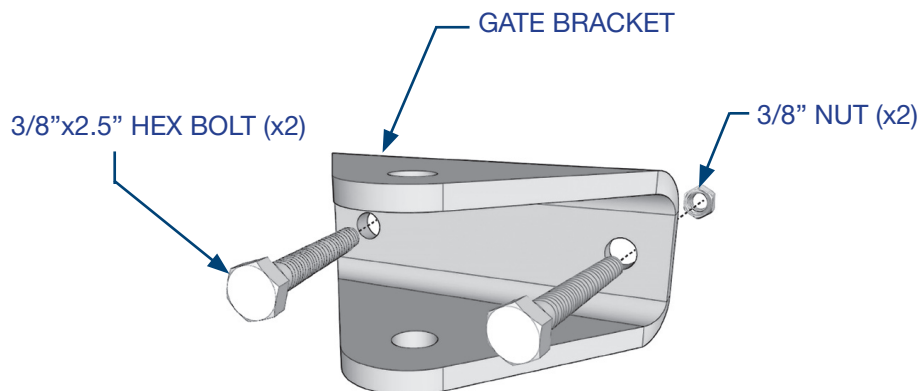

IMAGE 5-2: GATE BRACKET AND HARDWARE

IMPORTANT! Use a bubble level to assure after mounting that actuator is level and plumb.

1500 LA Installation and Programming Manual

SECTION 7: CBOX636 INSTALLATION

6 MOUNT CONTROL BOX

1. Mount control box on same side as primary actuator (for dual gate systems, same side as the actuator with shorter harness) and at least six feet away from pivot arm (IMAGE 6-1).
2. Set battery inside of control box with terminals toward the front.

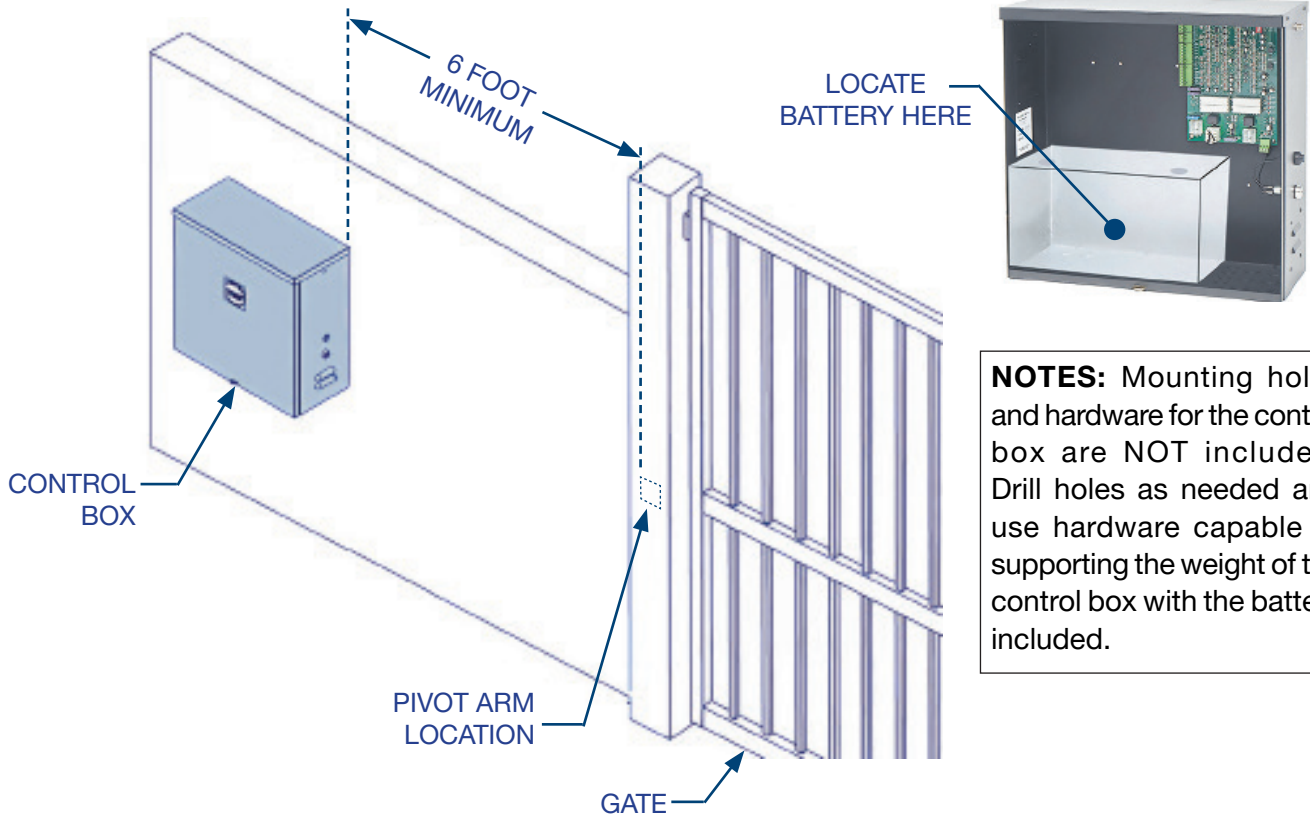

IMAGE 6-1: CONTROL BOX MOUNTING LOCATION

NOTE: IMAGE 6-1 shows a typical install. The control box may be installed on either side of the wall depending on which direction the gate opens or where a person monitoring the gate will be located.



CAUTION!

DO NOT MOUNT THE CONTROL BOX WHERE THE PERSON USING THE PUSH BUTTON ON SIDE OF BOX CAN COME IN CONTACT WITH THE GATE!

1500 LA Installation and Programming Manual

7

RUN ACTUATOR CABLE(S) TO CONTROL BOX

Run the cable of the actuator closest to the control box through a hole (with rubber grommet) drilled in the bottom on the control box. If necessary, entry may be made elsewhere on the control box.

If a dual gate installation:

1. Dig a trench across the driveway deep enough to accommodate the longer harness cable from the actuator farthest from the control box.
2. Run the cable through an appropriate conduit and lay this in the trench.
3. Cover the trench and use asphalt patch if needed.
4. Run the 2nd cable into a hole (with rubber grommet) into the bottom of the control box.

NOTE: Ensure the cable(s) reaches into the control box sufficiently to reach the MOTOR inputs on the control board.

1500 LA

Installation and Programming Manual

SECTION 8: ACTUATOR WIRING & CONNECTIONS

There are two actuator input connectors on the 636 control board, MASTER and SLAVE. The MASTER connector is used for single gate systems, and the SLAVE is used when a second actuator is used for a dual gate configuration.

For a single gate system, the unused SLAVE connector is populated by a connector with jumpers (FIGURE 8-1).

Pull-to-Open (Standard) and Push-to-Open configurations use different wiring in the actuator harness/connector to reverse limit detection (PINS 1 & 2) and motor direction (PINS 3 & 4).

NOTE: Refer to INSTRUCTION 2B for instructions for rewiring connector for Push-To-Open configurations.

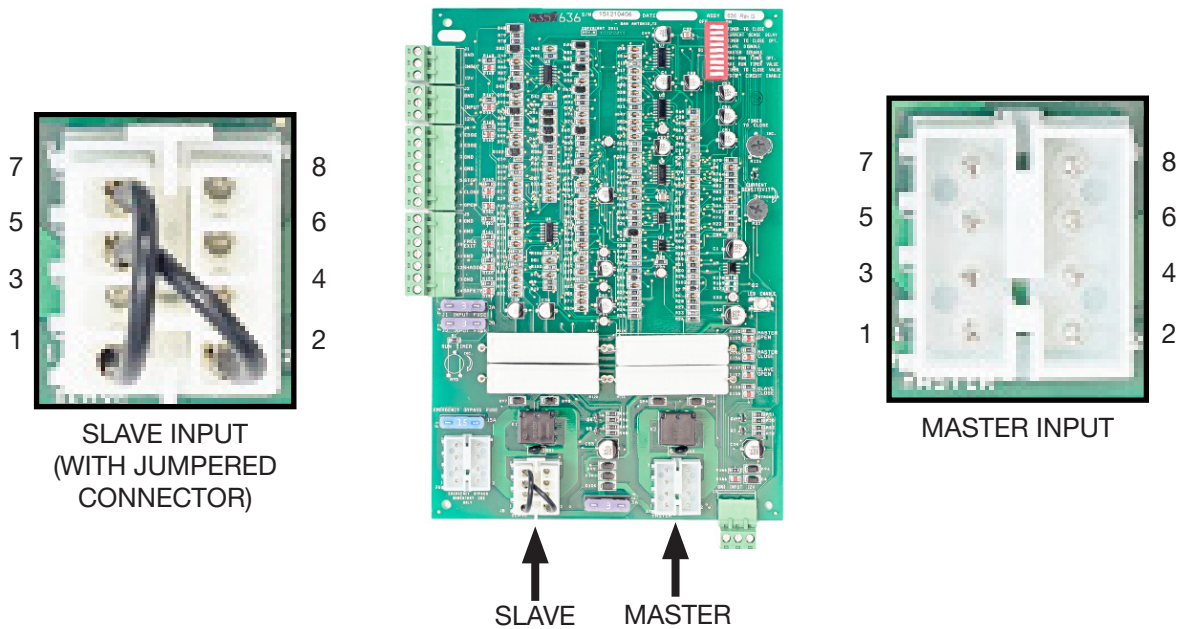

FIGURE 8-1: ACTUATOR CONNECTORS

NOTE: The unused SLAVE connector is populated with jumpered connector for single gate system, as shown in FIGURE 8-1. This jumpered connector is removed if the SLAVE connector is used for a second actuator.

ACTUATOR WIRING (PULL-TO-OPEN)		
PIN	COLOR	FUNCTION
1	ORANGE	Open Limit Input
2	WHITE	Close Limit Input
3	BLACK	Motor -
4	RED	Motor +
5	GREEN	Limit Switch Common
6	---	N/C
7	BLACK	Battery Negative
8	RED	Battery Positive
	BLUE	Encoder

ACTUATOR WIRING (PUSH-TO-OPEN)		
PIN	COLOR	FUNCTION
1	WHITE	Close Limit Input
2	ORANGE	Open Limit Input
3	RED	Motor +
4	BLACK	Motor -
5	GREEN	Limit Switch Common
6	---	N/C
7	BLACK	Battery Negative
8	RED	Battery Positive
	BLUE	Encoder

1500 LA Installation and Programming Manual

8.1 816 ACTUATOR CABLE HARNESS AND BATTERY CONNECTIONS

The 816 actuator cable harness is shipped with connector and battery leads already installed for connecting to the 636 control board and battery for PULL-TO-OPEN systems. For PUSH-TO-OPEN configurations, it is necessary to rewire the actuator connector (see INSTRUCTION 8B).

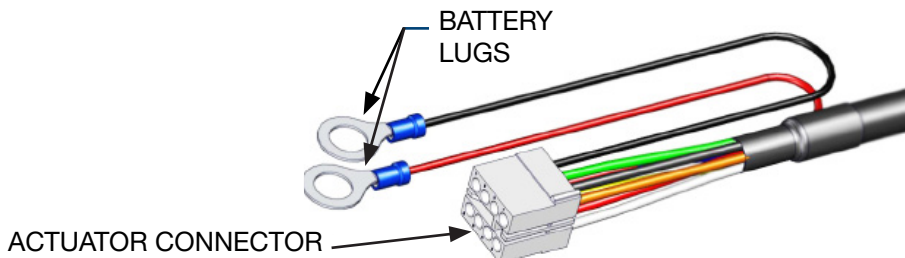

FIGURE 8-2: 816 EXISTING CONNECTOR & BATTERY LEADS ON 816 ACTUATOR CABLE

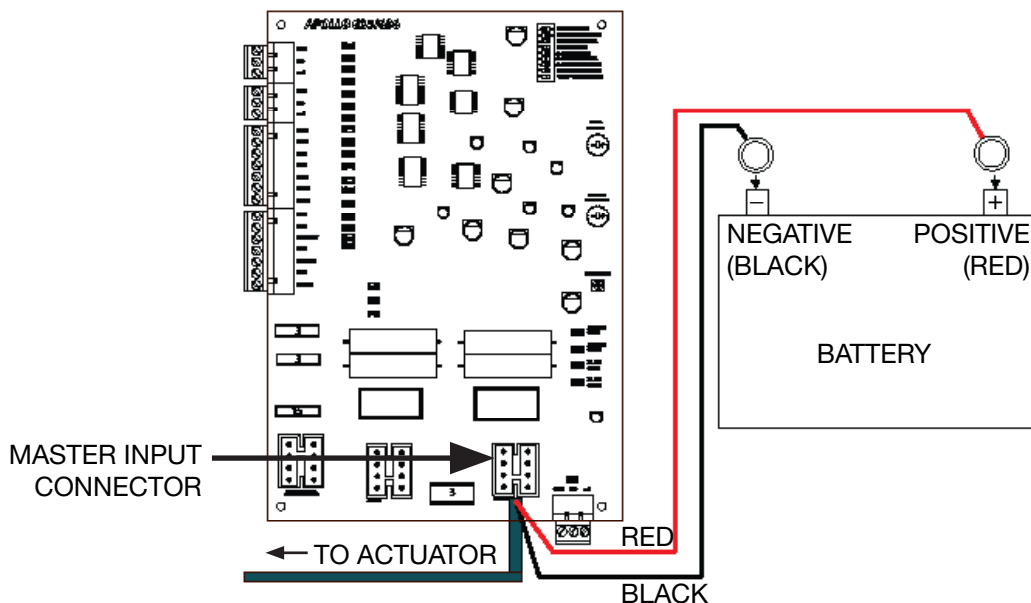

FIGURE 8-3: BATTERY CONNECTION FROM ACTUATOR HARNESS (SINGLE GATE SHOWN)

NOTES:

- For dual gate systems, once the primary actuator harness battery leads are connected to the battery, it is not necessary to connect the battery leads of the secondary actuator cable harness.
- The actuator closest to the control box (with shortest actuator harness), is connected to the MASTER (MOTOR 1) connector on the control board.
- The actuator farthest from the control box (longest harness) is connected to the SLAVE (MOTOR 2) connector.
- Note that wiring connections are different for Pull-to-Open and Push-to-Open installations.

1500 LA Installation and Programming Manual

8A

ACTUATOR CONNECTIONS: PULL-TO-OPEN

1. Locate the MASTER and SLAVE input connectors on the 636 control board per FIGURE 8-1.
2. Plug the primary actuator harness connector into the MASTER connector on the 636 control board (IMAGE 8A-1).
3. Connect the two battery lugs of the primary actuator cable from the actuator harness(es) to the battery; red to positive (+) and black to negative (-).
4. For dual gate configurations, remove the existing jumpered connector from the SLAVE connector, then plug the secondary actuator (with longer harness) into the SLAVE connector. Do not use the battery cables from the secondary actuator cable, as the primary actuator cable battery cables have already been connected in Step 3.

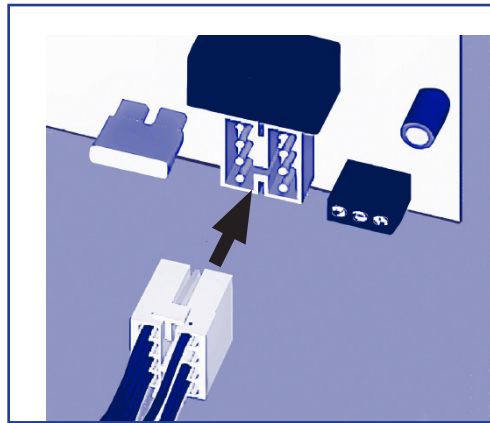
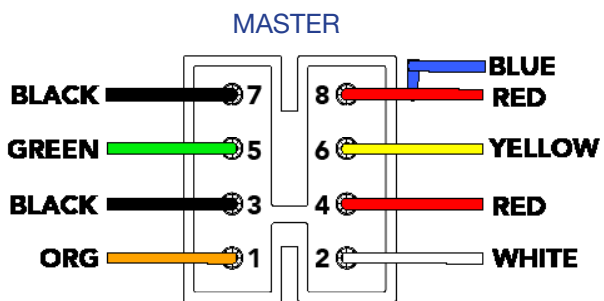

IMAGE 8A-1: SINGLE GATE - PULL-TO-OPEN WIRING

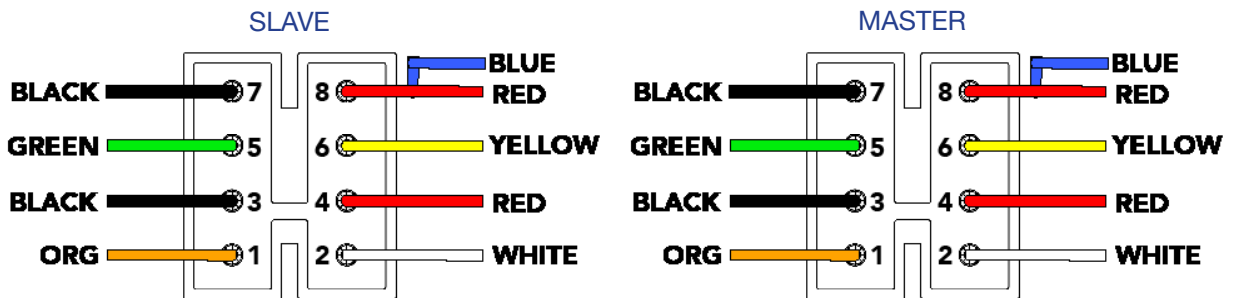

IMAGE 8A-1: DUAL GATE - PULL-TO-OPEN WIRING

1500 LA Installation and Programming Manual

8B

ACTUATOR CONNECTIONS: PUSH-TO-OPEN

PUSH-TO-OPEN configurations require that the actuator connectors be rewired as follows:

1. Reverse wires on pins 1 and 2 (orange & white, limit switch wires), IMAGE 8B-1.
2. Reverse wires on pins 3 and 4 (black & red, motor wires), IMAGE 8B-1.

NOTE: See next page for tips on rewiring the Tyco connector.

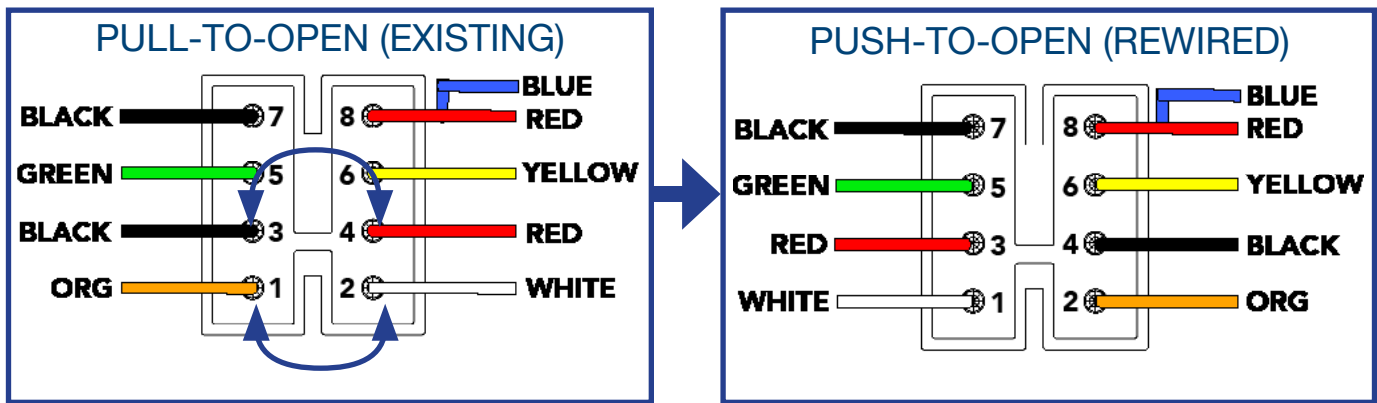

IMAGE 8B-1: HARNESS REWIRING FOR PUSH-TO-OPEN INSTALLATIONS

3. Locate the MASTER and SLAVE input connectors on the 636 control board per FIGURE 8-2.
4. Plug the primary (shorter harness) actuator connector into the MASTER connector on the 636 control board.
5. For dual gate configurations, remove the existing jumpered connector from the SLAVE connector, then plug the secondary actuator (longer harness) into the SLAVE connector.
6. Connect the two battery lugs from the MASTER actuator harness to the battery; red to positive (+) and black to negative (-). See FIGURE 8-3.

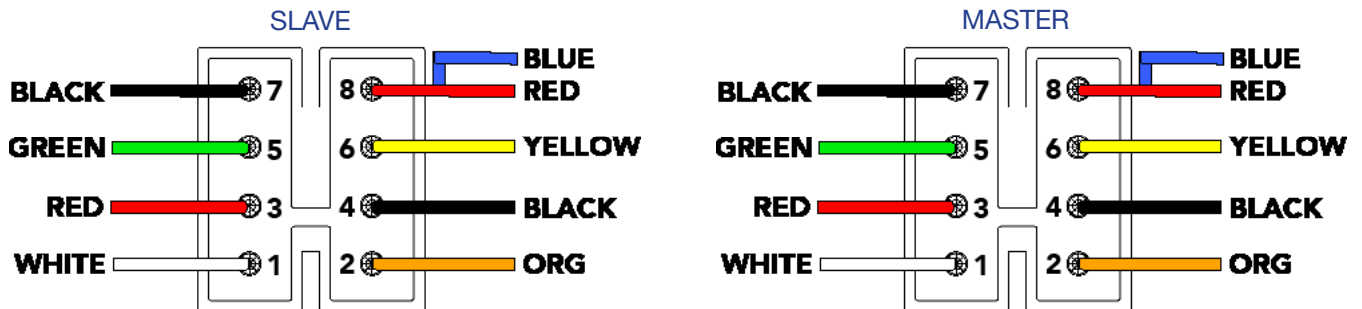

IMAGE 8B-2: DUAL GATE - PUSH-TO-OPEN WIRING

1500 LA Installation and Programming Manual

TIPS: REWIRING TYCO CONNECTORS

Switch wires by removing the pin/wire from Tyco connector and reinserting into new position using a very small screwdriver or the Tyco extraction tool (TE P/N 305183, follow manufacturers instructions). To use a small screwdriver instead of the extraction tool, see below:



TYCO PIN EXTRACTION/INSERTION TOOL

1. Change wires by inserting small screwdriver into the front of connector next to the pin/wire as shown below, pushing in tab on pin, then pulling pin/wire from rear of connector. After reinserting into new position, tab should snap into place and hold the wire pin in place.

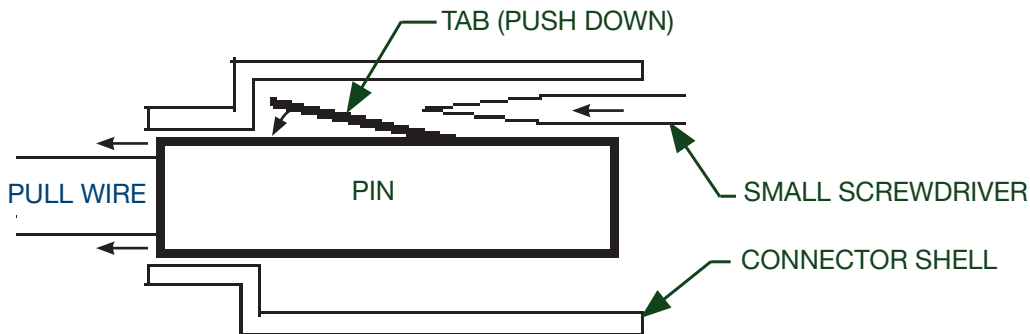

REMOVING PIN/WIRE WITH SMALL SCREWDRIVER (SIDE VIEW)

9

ATTACH WARNING SIGNS TO GATE

1. Place the warning signs (IMAGE 9-1) on outside and inside of gate in high visibility locations (eye height) to warn of entrapment dangers. If signs cannot be attached to gate, ensure they are as visible as possible to pedestrians and anyone operating the gate.
2. Use two tie wraps per sign, or alternative means, to securely affix signs to the gate.

IMAGE 9-1: GATE ENTRAPMENT WARNING SIGN



1500 LA

Installation and Programming Manual

SECTION 9: BATTERY CHARGING OPTIONS: AC & SOLAR

The control board is powered once the actuator(s) harness battery wires are connected to the 12 VDC battery (see INSTRUCTIONS 8A and 8B), but the battery itself must be recharged using either a battery charging device or solar panel(s).

- If AC electrical power will be run to the control box to allow the use of an AC-DC charger to recharge the battery, refer to wiring and safety information below. See INSTRUCTION 10 for AC-DC charger information.
- If solar panels are used, refer to INSTRUCTIONS 11A and 11B.

9.1 120VAC ELECTRICAL WIRING AND SAFETY



CAUTION!

DO NOT WIRE AC POWER TO THE CONTROL BOARD! THE CONTROL BOARD OPERATES ON DC POWER ONLY!

- Disconnect power to the gate operator by manually opening its dedicated circuit breaker before making any mechanical or electrical adjustments.
- Use a 20 amp dedicated circuit breaker for each installed gate operator.
- Open dedicated circuit breaker supplying power to gate operator before a new installation or making any modifications to an existing installation of this gate operator.
- All wiring connections must be made by a qualified individual.
- Run individual circuits in separate U.L. Listed conduits. Do not combine high voltage (120vac) power wiring and low voltage (+12vdc to +24vdc) control wiring in the same conduits.



DANGER!

TO REDUCE THE RISK OF SEVERE INJURY AND DEATH FOLLOW ALL SAFETY PROCEDURES!



DANGER!

DO NOT WIRE AC MAINS POWER TO METAL CONTROL BOX WITHOUT EARTH GROUND CONNECTION!

IF AC POWER IS BEING RUN INTO THE CONTROL BOX FOR CONVERSION TO DC, IT IS RECOMMENDED THAT THE GATE OPERATOR SYSTEM SHOULD BE GROUNDED THROUGH THE EARTH GROUND IN THE AC MAINS WIRING SYSTEM (GREEN WIRE). This ground connection will prevent dangerous currents from appearing on the metal control box, the actuator, or the gate itself.

Nice recommends an 8 foot copper rod driven all the way into the ground with a copper clamp and 12ga copper wire minimum.

Connect ground wire to the control box by drilling a hole in the control box, removing the powder coating around the hole, and bonding the copper ground wire to that area with a bolt.

1500 LA

Installation and Programming Manual

9.2 HIGH VOLTAGE WIRE GAUGE REQUIREMENTS

Use Table 9-1, below, to determine high voltage wire size requirements. Distance shown in the chart is measured from the operator to the power source. If power wiring is greater than the maximum distance shown, a service feeder is recommended. When large gauge wire is used, a separate junction box must be installed for the operator connection.

Wire table is based on stranded copper wire. Wire run calculations are based on a 110 VAC power source with a 3% voltage drop on the power line, plus an additional 10% reduction in distance to allow for other electrical losses in the system.

TABLE 9-1: MAXIMUM RUN PER WIRE GAUGE						
110V/AWG GAUGE	14	12	10	8	6	4
MAX RUN	180 FT (54.8m)	280 FT (85.3m)	460 FT (140m)	700 FT (213.3m)	1150 FT (350.5m)	1800 FT (548.6m)

9.3 AC-TO-DC CHARGER CONNECTIONS

Nice offers an AC-DC battery charger (P/N 404c) as shown in IMAGE 10-1. If using a different charger, refer to the manufacturers instructions for installation.

10

CONNECT AC-DC CHARGER TO BATTERY

1. Attach the battery cables from the charger (IMAGE 4-1) to the battery terminals; red to positive (+) and black to negative (-).
2. Plug the charger into an appropriate AC source (see previous page for AC power safety warnings).



IMAGE 10-1: AC-TO-DC BATTERY CHARGER (P/N 404C)

1500 LA Installation and Programming Manual

9.4 SOLAR PANEL CONNECTIONS

11A SOLAR PANEL CONNECTION - Up TO 10W

Any solar panel rated at 10W (watts) or smaller, may be installed directly to the battery as follows:

1. Assemble solar panel mounting bracket and panel with included hardware.
2. Locate solar panel out of shadows of surrounding buildings, walls, etc. and orient to collect the maximum sunlight energy throughout the year. In the northern hemisphere, mount panels at upward angle of about 45 degrees with panel oriented south. In the southern hemisphere orient the panel to face north.
3. Connect battery lugs directly to the battery (red wire to positive and black wire to negative).

NOTE: For all solar panels rated above 10 Watts, an external charge regulator *must* be used. Nice offers a regulator (P/N SG-4) for this purpose. See INSTRUCTION 11B for installation instructions for the SG-4 regulator.

1500 LA Installation and Programming Manual

11B SOLAR PANEL CONNECTION - above 10 WATTS

Solar panels rated above 10W **must** be connected to a charge regulator, which in turn then connects to the battery to enable battery charging. Nice offers a regulator (P/N SG-4) for this purpose. For other regulators, follow the manufacturers instructions. Connect any solar panel above 10W using the SG-4 regulator as follows:

1. Assemble solar panel mounting bracket and panel with included hardware.
2. Locate solar panel out of shadows of surrounding buildings, walls, etc. and orient to collect the maximum sunlight energy throughout the year. In the northern hemisphere, mount panels at upward angle of about 45 degrees with panel oriented south. In the southern hemisphere orient the panel to face north.
3. Drill two holes into a vertical surface in the CBOX chassis matching the two mounting tabs on the regulator. Mount the SG-4 with appropriate hardware to fix it in place.

CAUTION! Do not attach wires to battery until STEP 5.

4. Connect:
 - Solar panel RED wire to regulator YELLOW wire.
 - Solar panel BLACK wire to **either** regulator BLACK wire.
 - Battery cable RED wire (positive) to regulator RED wire.
 - Battery cable BLACK wire (negative) to other regulator BLACK wire.
5. Attach both battery lugs to the battery (red to positive and black to negative).

NOTES:

- Wire-to-wire connections may use wire nuts, crimp caps, or butt connectors, as long as the connections are secure.
- It is permissible to cut off 8" to 10" (or so) of the solar panel wires (with battery lugs) in order to use for attaching the regulator to the battery.
- The SG-4 prevents reverse current leakage at night, so a blocking diode is not required in the system.
- A negative earth ground at the battery is recommended for most effective lightning protection.
- The SG-4 can be mounted outdoors, but do not expose to ambient temperatures above 140°F (60°C).
- Ensure that water is able drain from inside the case if it becomes wet.

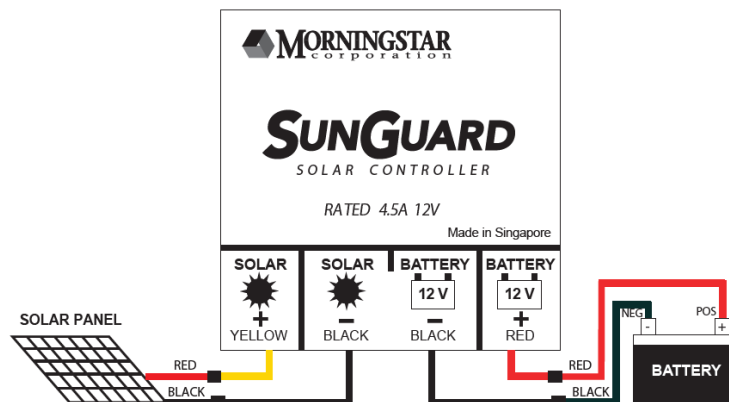

IMAGE 11B-1: P/N SG-4 SOLAR PANEL REGULATOR WIRING

1500 LA Installation and Programming Manual

9.5 SETTING OPEN/CLOSE LIMITS

12A SETTING MASTER GATE OPEN/CLOSE LIMITS

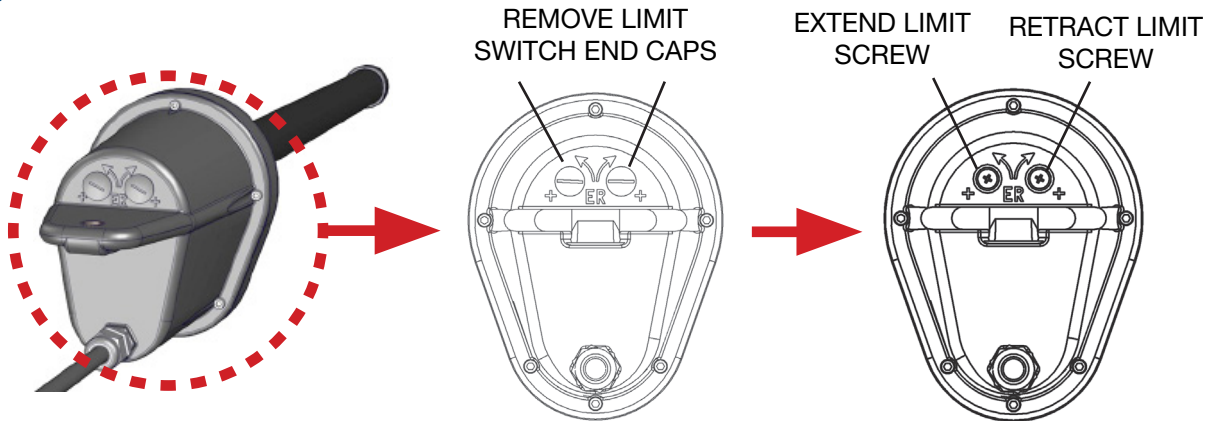

IMAGE 12A-1: 816 ACTUATOR LIMIT SWITCH LOCATIONS

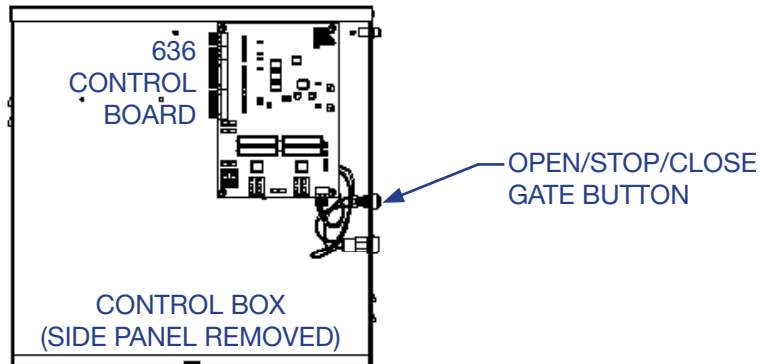

IMAGE 12A-2: OPEN/STOP/CLOSE BUTTON LOCATION ON CBOX636 (SIDE VIEW)

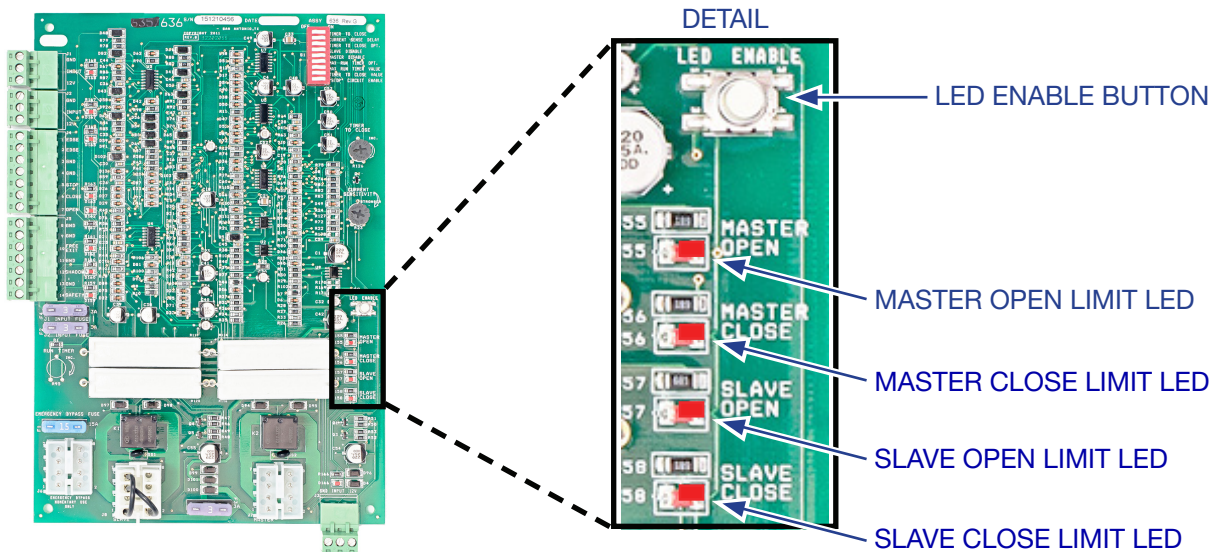

IMAGE 12A-3: OPEN/CLOSE LIMIT LEDS ON 636 CONTROL BOARD

(Continued)

1500 LA

Installation and Programming Manual

12A: SET MASTER GATE OPEN/CLOSE LIMITS (CONT.)

(Continued)

After connection of actuator and battery leads, the gate should now open or close when the black button on the control box (see FIGURE 12A-2) is pressed.

NOTE: For dual gate installations, leave the SLAVE actuator disconnected until after the MASTER actuator has been limit adjusted. See INSTRUCTION 6B for SLAVE adjustment instructions.

1. Remove the cap(s) from the limit screws on the actuator (IMAGE 12A-1).
2. With the gate in the closed position depress the LED ENABLE button on 636 board (IMAGE 12A-3). You should see the MASTER CLOSE limit LED illuminate.
3. Using the black button on the side of the control box (IMAGE 12A-2), cycle the operator to the open position. If the actuator does not stop before reaching the fully open position depress the black button to stop the motor in the desired open position.
4. Adjust the retract (pull to open) or extend (push to open) limit as shown on previous page. Turn the limit screw until the MASTER OPEN limit LED illuminates (while holding the LED enable button).
 - EXTEND more: Turn the limit screw counterclockwise
 - EXTEND less: Turn the limit screw clockwise
 - RETRACT more: Turn the limit screw clockwise
 - RETRACT less: Turn the limit screw counterclockwise
5. If installing a dual gate system, proceed to INSTRUCTION 12B. If installing a single gate configuration, proceed to INSTRUCTION 13.

12B SETTING SLAVE GATE OPEN/CLOSE LIMITS

1. After following instructions in INSTRUCTION 12A for adjusting limit switch of the MASTER actuator, follow the steps below to set the SLAVE gate actuator.
2. Once the MASTER gate actuator is set, disconnect it from board and plug the SLAVE gate harness into the MASTER side of the circuit board.
3. Follow the same steps to set the limit for the SLAVE as done for the MASTER actuator.
4. Once both actuators are set, plug the MASTER gate actuator into the master connector on the board and SLAVE gate actuator into the slave connector on the board.
5. Proceed to INSTRUCTION 13.

1500 LA Installation and Programming Manual

9.6 RECEIVER/TRANSMITTER INSTALLATION & PROGRAMMING

13 INSTALL MGR RECEIVER AND ANTENNA



IMAGE 13-1: MGR RECEIVER

1. Install the MGR radio receiver (IMAGE 13-1) inside the control box (hardware not included), ensuring that receiver harness is able to reach the 636 control board.
2. Refer to IMAGE 13-2 and remove the empty connector at J1.
3. Plug the radio harness connector into the vacant J1 connector (IMAGE13-2).

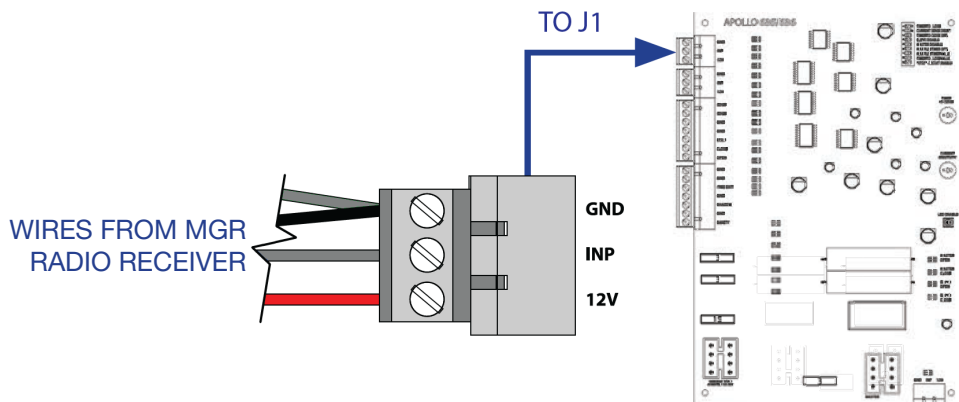

IMAGE 13-2: MGR RECEIVER TO 636 CONTROL BOARD CONNECTION

MGR WIRE HARNESS TO 636		
MGR	WIRE COLOR	636
TERM. 1	RED	12VDC
TERM. 2	BLACK	GND
TERM. 3	GRAY	
TERM. 4	GRAY	INPUT

1500 LA Installation and Programming Manual

14

PROGRAMMING TRANSMITTERS FOR MGR

1. Open the receiver cover by removing the screws, squeezing the sides of the case and rotating upward (IMAGE 14-1).

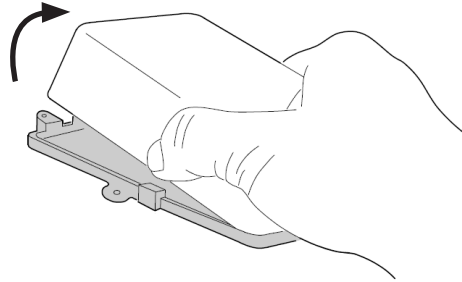

IMAGE 14-1: REMOVE 318N RECEIVER COVER

2. The program button labeled S1 is used to program transmitters to channel one (IMAGE 14-2).

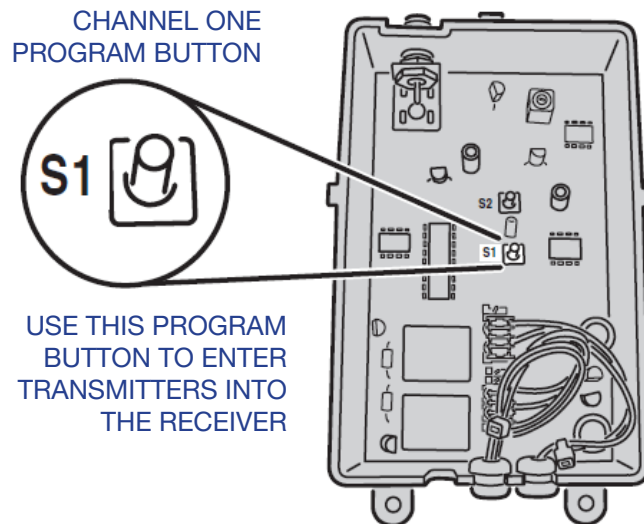

IMAGE 14-2: PROGRAM BUTTON S1

1500 LA Installation and Programming Manual

14: PROGRAMMING TRANSMITTERS FOR MGR

(Continued)

3. Momentarily press the receiver program button (IMAGE 14-3). The red programming LED will light if there is room in the receiver memory for additional transmitters (40 maximum per receiver). The LED stays on for about 5 seconds. **A transmitter must be entered while the LED is on.**

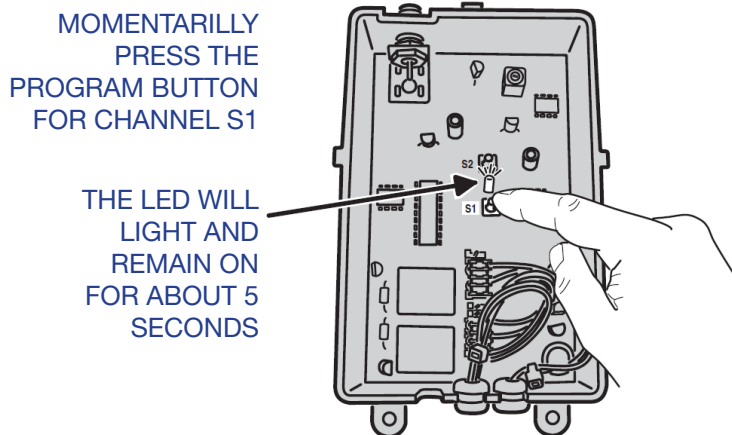
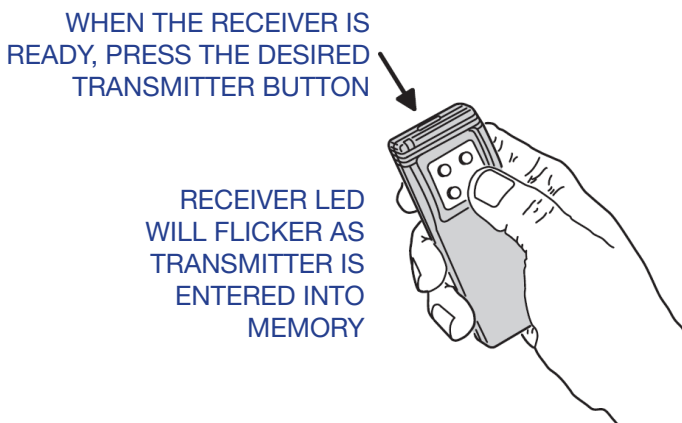

IMAGE 14-3: PRESS AND HOLD PROGRAM BUTTON S1 UNTIL LED TRUNS ON

4. Press the desired transmitter button for less than 2 seconds (IMAGE 14-4). The LED will flicker indicating that the receiver has accepted the transmitter.



NOTE: Be sure to press the receiver program button for less than 2 seconds.

IMAGE 14-4: PRESS DESIRED TRANSMITTER BUTTON FOR LESS THAN 2 SECONDS

IMPORTANT! Operator will not activate when the receiver is being programmed from the transmitter, but it will activate the next time the transmitter is activated after programming.

5. Repeat Step 3 and Step 4 for each transmitter used with this receiver. Be sure to press the receiver program button **each time a new transmitter or a different transmitter buton on a multi-button transmitter is pressed.**

NOTE: If the LED does not turn on when the receiver program button is pressed, the receiver memory is full. Use the erase function (Info 1) to remove undesired transmitters from the receiver memory.

1500 LA Installation and Programming Manual

15

INFO 1: DELETING A TRANSMITTER FROM MEMORY

1. Press and hold the receiver program button (IMAGE 14-5). The LED will flash (counting number of transmitters in memory), and then will blink one more time to indicate that the transmitters have all been erased from memory.

IMPORTANT! All transmitters are erased at the same time.

2. When the LED stops flashing, release the receiver program button.

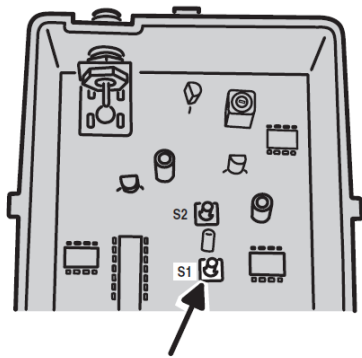

PRESS AND HOLD RECEIVER
PROGRAM BUTTON FOR DURATION
OF DELETION PROCESS

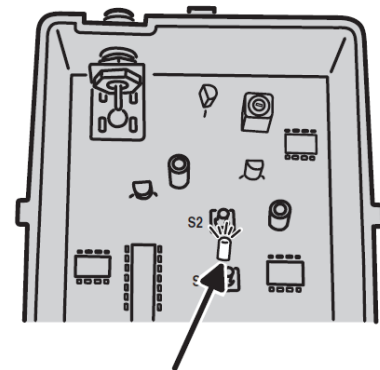

LED WILL FLASH, COUNTING TOTAL NUMBER
OF TRANSMITTERS IN MEMORY. THEN IT
WILL BLINK ONCE TO INDICATE THAT THEY
HAVE ALL BEEN ERASED FROM MEMORY.

IMAGE 14-5: ERASING TRANSMITTERS FROM MEMORY

1500 LA Installation and Programming Manual

SECTION 10: 636 CONTROL BOARD FEATURES

10.1 EMERGENCY BYPASS CONNECTOR

16

USING THE EMERGENCY BYPASS CONNECTOR

The emergency bypass connector is used to open the gate(s) even if the control box open/close gate button is locked. Instructions for use are as follows:

1. Unplug the motor harness from the Master (or Slave) Connector and momentarily insert into the Emergency Bypass Connector to open the gate.

NOTE: Using the emergency bypass connector only applies motor power to the actuator(s) to open the gate(s), with no limit function, closing function, or other setting options.

2. Make sure to unplug the connector from the emergency bypass before the gate fully opens and binds.
3. In the event the motor is not disconnected quickly enough, the blue 15 amp fuse (see IMAGE 17-1) will protect the circuit board from damage and should be replaced when the original problem is fixed.

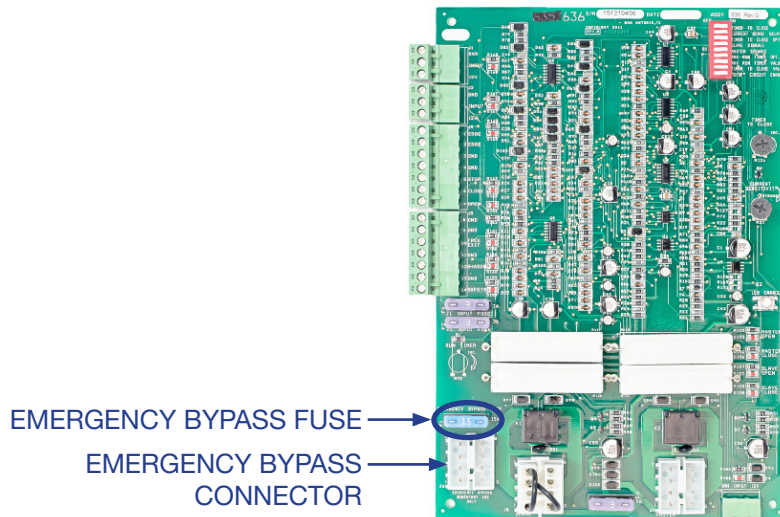

IMAGE 17-1: EMERGENCY BYPASS CONNECTOR AND FUSE LOCATIONS

1500 LA Installation and Programming Manual

10.2 636 CONTROL BOARD CONTROLS, SWITCHES, & FUSES

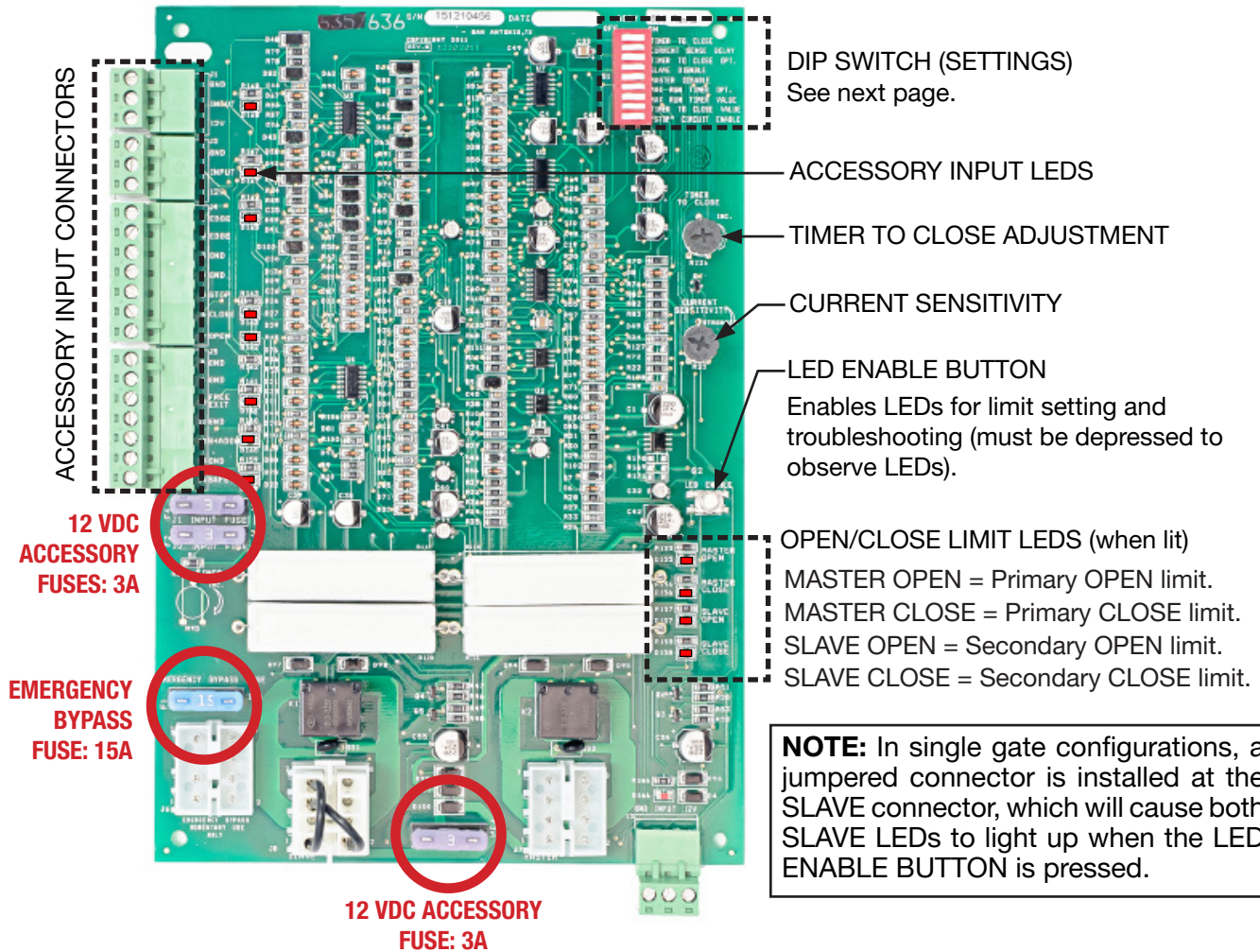

FIGURE 10-1: 636 CONTROL BOARD CONTROLS, SWITCHES, & FUSES

TIMER TO CLOSE ADJUSTMENT

Rotate clockwise to increase time before gate closes, and counter-clockwise to decrease time before gate closes. If program switch #3 is on, the gate must activate the open limit switch in order for the timer to close to operate.

CURRENT SENSITIVITY

Rotate clockwise to decrease sensitivity (more force) and counter-clockwise to increase sensitivity (less force).

WARNING: The current sensitivity should be adjusted to prevent injury in the event of someone being entrapped in the gate. This feature should be periodically tested to assure proper operation. Refer to SAFETY PRECAUTIONS in SECTION 3.

ACCESSORY INPUT LEDS

A lit red LED to the right of an accessory input indicates that the accessory is connected and functioning.

1500 LA

Installation and Programming Manual

10.3 DIP SWITCH SETTINGS

DIP SWITCH SETTINGS

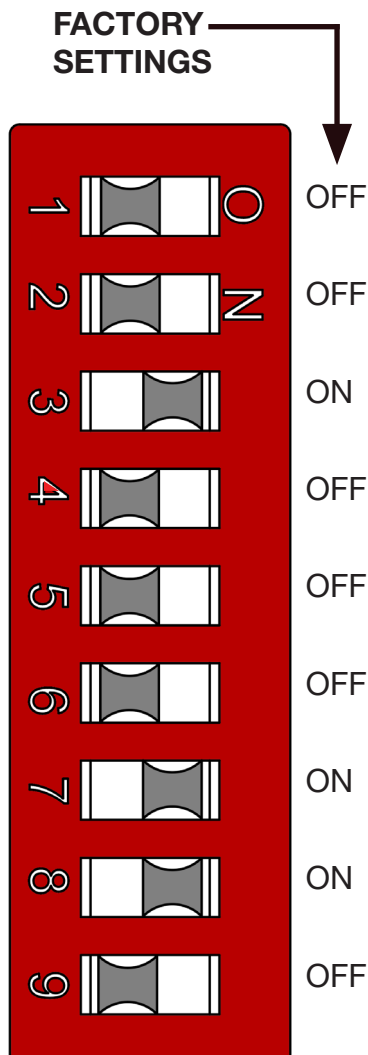

1 - **TIMER TO CLOSE** - Automatically closes gate

- ON - Close timer enabled
- OFF - Close timer disabled (FACTORY)

2 - **CURRENT SENSITIVITY OPTION** - Delays current sensing from start up

- ON - 4 second delay
- OFF - 2 second delay (FACTORY)

3 - **TIMER TO CLOSE OPTION**

- ON - timer to close works only when open limit switch is activated (FACTORY)
- OFF - timer to close works from any open gate position

4 - **SLAVE DISABLE**

- ON - disables slave side of dual board
- OFF - enables slave side of dual board (FACTORY)

5 - **MASTER DISABLE**

- ON - disables master side of dual board
- OFF - Enables master side of dual board (FACTORY)

6 - **MAXIMUM RUN TIMER OPTION**

- ON - stops and reverses gate if run timer times out before closing
- OFF - stops gate if run timer times out before closing (FACTORY)

7 - **MAXIMUM RUN TIMER VALUE**

- ON - 40 seconds (FACTORY)
- OFF - 20 seconds

8 - **TIMER TO CLOSE VALUE**

- ON - 20 to 70 seconds (adjustable) (FACTORY)
- OFF - 10 to 35 seconds (adjustable)

9 - **OPEN, STOP, CLOSE CONTROL ENABLE**

- ON - allows for open, stop, close unit (optional) to operate gate
- OFF - normal operation (If 9 is on, terminals 4 & 5 must be normally closed for proper operation.) (FACTORY)

1500 LA

Installation and Programming Manual

10.4 ACCESSORY CONNECTORS

A number of accessory inputs are provided on the 636 control board as shown below:

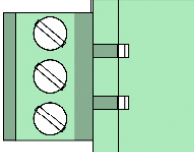
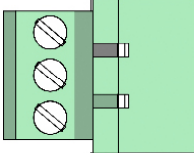
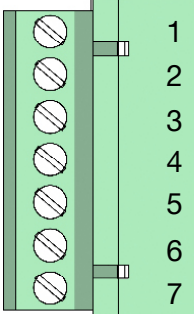
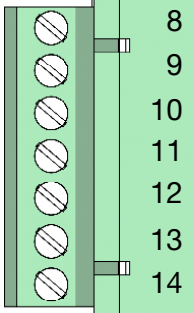
	GND	GND - Supplied Battery Ground
	INP	J1 INPUT - Step by Step activation
	12V	12V - Supplied battery voltage (protected with 3AMP fuse)
	GND	GND - Supplied Battery Ground
	INP	J2 INPUT - Step by Step activation
	12V	12V - Supplied battery voltage (protected with 3AMP fuse)
	1	EDGE EDGE - Reverse edge input. Stop and reverse gate if closing, resets close timer if gate open.
	2	EDGE EDGE - Reverse edge input. Stop and reverse gate if closing, resets close timer if gate open.
	3	GND GND - Supplied Battery Ground
	4	GND GND - Supplied Battery Ground
	5	STOP STOP - Stop input from a 3 button station
	6	CLOSE CLOSE - Close input from a 3 button station
	7	OPEN OPEN - Open input from a 3 button station
	8	GND GND - Supplied Battery Ground
	9	GND GND - Supplied Battery Ground
	10	FREE EXIT FREE EXIT - Opens gate if closed, stops and reverses gate if closing, resets close timer if gate is open.
	11	GND GND - Supplied Battery Ground
	12	SHADOW SHADOW - Resets close timer when gate is open (also referred to as under gate loop)
	13	GND GND - Supplied Battery Ground
	14	SAFETY SAFETY - Resets close timer if gate is open, stops and reverses if gate is closing. Does not open a closed gate.

1500 LA Installation and Programming Manual

SECTION 11: APPENDIX

11.1 CALCULATING SOLAR REQUIREMENTS

17

CALCULATING SOLAR REQUIREMENTS

- Estimate gate traffic measured in open/close cycles per the **Watt/Cycle Chart** below and refer to the notes.

SOLAR PANEL WATT/CYCLE CHART							
DAILY CYCLES	1-10	1-20	1-30	1-40	1-60	1-80	80+
5 Watt Solar Panel	x						
10 Watt Solar Panel		x					
15 Watt Solar Panel (requires regulator)			x				
20 Watt solar Panel (requires regulator)				x			
30 Watt Solar Panel (requires regulator)					x		
40 Watt Solar Panel (requires regulator)						x	
1.5 Amp Battery Charger						x	
10 Amp Battery Charger							x

NOTES:

- The **Solar Panel Watt/Cycle Chart** is only a guide. Other gate operator configurations may reduce or increase the daily power usage.
- For all solar panels rated above 10 Watts, an external charge regulator must be used.
- For dual gate operators, double the amount of required solar wattage.
- If a standard electrical outlet is not available for trickle charging, a licensed electrician will be required for proper electrical hookup.

- Estimate the amount of sunlight available per the Solar Map at right.
- Use the solar wattage calculator found on the HySecurity website at <https://support.hysecurity.com/hc/en-us/articles/360057403914> to determine battery and solar panel size needed to serve the installation in question.

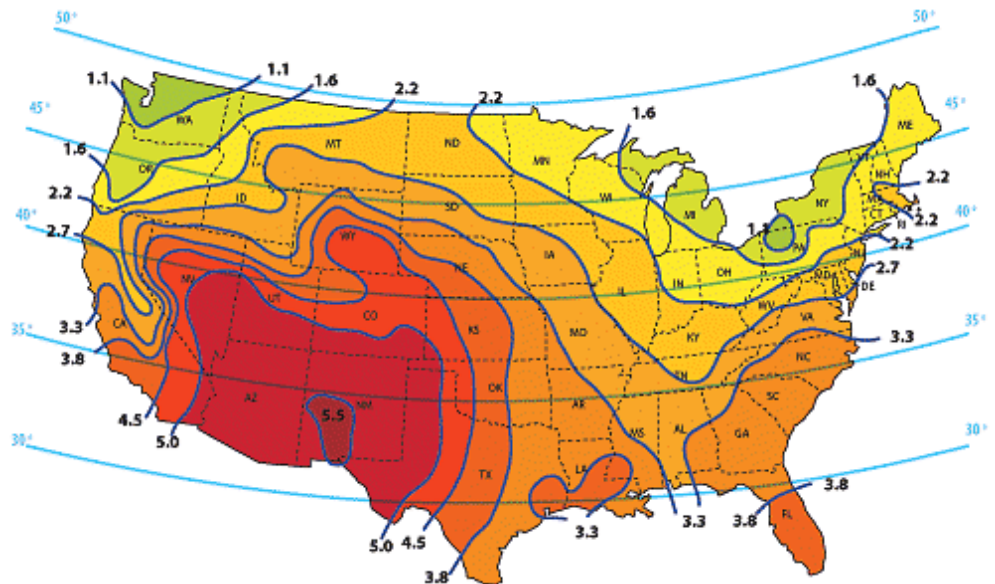

1500 LA Installation and Programming Manual

11.2 MAINTENANCE SCHEDULE

MAINTENANCE SCHEDULE			
	Maintenance Action	6 Months	Annually
BATTERY	Check the batteries for any leakage or loose connections. It is recommended that batteries be replaced every two years.	X	X
EMERGENCY BYPASS	Check emergency bypass function for proper operation. See SECTION 10.1 for more information.	X	X
GATE	Inspect for damage.		X
LOOP(S)	Check vehicular reverse and shadow loops for proper operation.	X	X
MOUNTING HARDWARE	Check screws and nuts.		X
PHOTO EYES	Use a hand held cylinder (approx. 2" [5cm] diameter and 12" [30cm] in length) and pass between photo eye line of sight. Pass cylinder through line of sight near transmitter, pass cylinder through line of sight near receiver, pass cylinder through line of sight halfway between transmitter and receiver. Gate should stop and reverse on detection. Check for humidity, oxidation, and foreign bodies (such as insects) and remove from chassis. Clean housings and front plate. Do not use alcohol, benzene, abrasives or other cleaning products. Use only a slightly dampened soft cloth to clean transmissive panels or lenses.	X	X

1500 LA Installation and Programming Manual

11.3 SYSTEM TROUBLESHOOTING

SYSTEM TROUBLESHOOTING	
Problem	Possible Solution
Gate opens a short distance, then stops and reverses.	<ul style="list-style-type: none"> • Check the UL/Edge input on the gate controller. • Ensure limit LEDs are functioning properly. • Check for obstructions. • Adjust Force Settings.
Gate opens but will not close.	<ul style="list-style-type: none"> • Check the input LEDs. Any ON will hold the gate open and indicates a problem with a keying device. Exception is "STOP". • Check limit LEDs. Check limits for failures. Replace as necessary. • Check the loop detectors. Any activated safety devices can hold the gate open and indicates a problem with the loop detector or ground loop.
Gate opens by itself.	Check accessory inputs and clear them as necessary.
636 status LEDs will not light up.	Check battery voltage and replace if necessary.
Gate moves in direction opposite expected.	Reverse the actuators Red and Black motor wires connected to the 636 control board.
Open limit LED glows when gate is closed, and close limit LED glows when gate is open.	Reverse the actuators Orange and White encoder wires connected to the 636 control board.

1500 LA

Installation and Programming Manual

11.4 INSTALLATION CHECKLIST

- The installer and customer must each ensure that all of the following actions have been completed.
- Left box is for installer check off and the right box is for customer check off.

INSTALLATION CHECKLIST		
<input type="checkbox"/>	<input type="checkbox"/>	The gate has been checked to make sure it is level and moves freely in both directions.
<input type="checkbox"/>	<input type="checkbox"/>	Potential pinch areas have been guarded so as to be inaccessible.
<input type="checkbox"/>	<input type="checkbox"/>	If pedestrian traffic is expected, a separate pedestrian gate has been installed, a minimum of seven feet from the gate. The customer has been informed that all pedestrian traffic must use the pedestrian gate.
<input type="checkbox"/>	<input type="checkbox"/>	Warning signs have been installed on each side of the gate in highly visible locations. The customer has been informed that these signs must remain at all times.
<input type="checkbox"/>	<input type="checkbox"/>	There are no controls installed within 6 feet of the gate.
<input type="checkbox"/>	<input type="checkbox"/>	The installer has properly adjusted the obstruction sensing feature and has tested the gate to make sure that the gate stops and reverses a short distance with minimal resistance applied (Approximately 40 lbs. on a swing gate, at the end of the gate).
<input type="checkbox"/>	<input type="checkbox"/>	The installer has instructed the customer in the proper use of the gate operator and reviewed all of the operational functions, obstruction sensing devices, warning beeper and reset, etc.
<input type="checkbox"/>	<input type="checkbox"/>	The installer has instructed the customer in the proper way of disconnecting the operator. Manual disconnect must never be used while the gate is in motion. The power must be turned off and battery disconnected before disengaging the operator.
<input type="checkbox"/>	<input type="checkbox"/>	The installer has reviewed all safety instructions with the customer, and has left the safety instructions and owner's manual for their reference.
<input type="checkbox"/>	<input type="checkbox"/>	The installer has answered any questions the customer has regarding the operation of the gate operator and gate operator safety precautions.
<input type="checkbox"/>	<input type="checkbox"/>	The installer has explained to the customer that a regular maintenance schedule for both the gate and the gate operator is recommended.
<input type="checkbox"/>	<input type="checkbox"/>	The installer has given any keys for the control box to the customer and explained how to manually open the gate in the event of a loss of power.

1500 LA Installation and Programming Manual

11.5 PART DRAWINGS

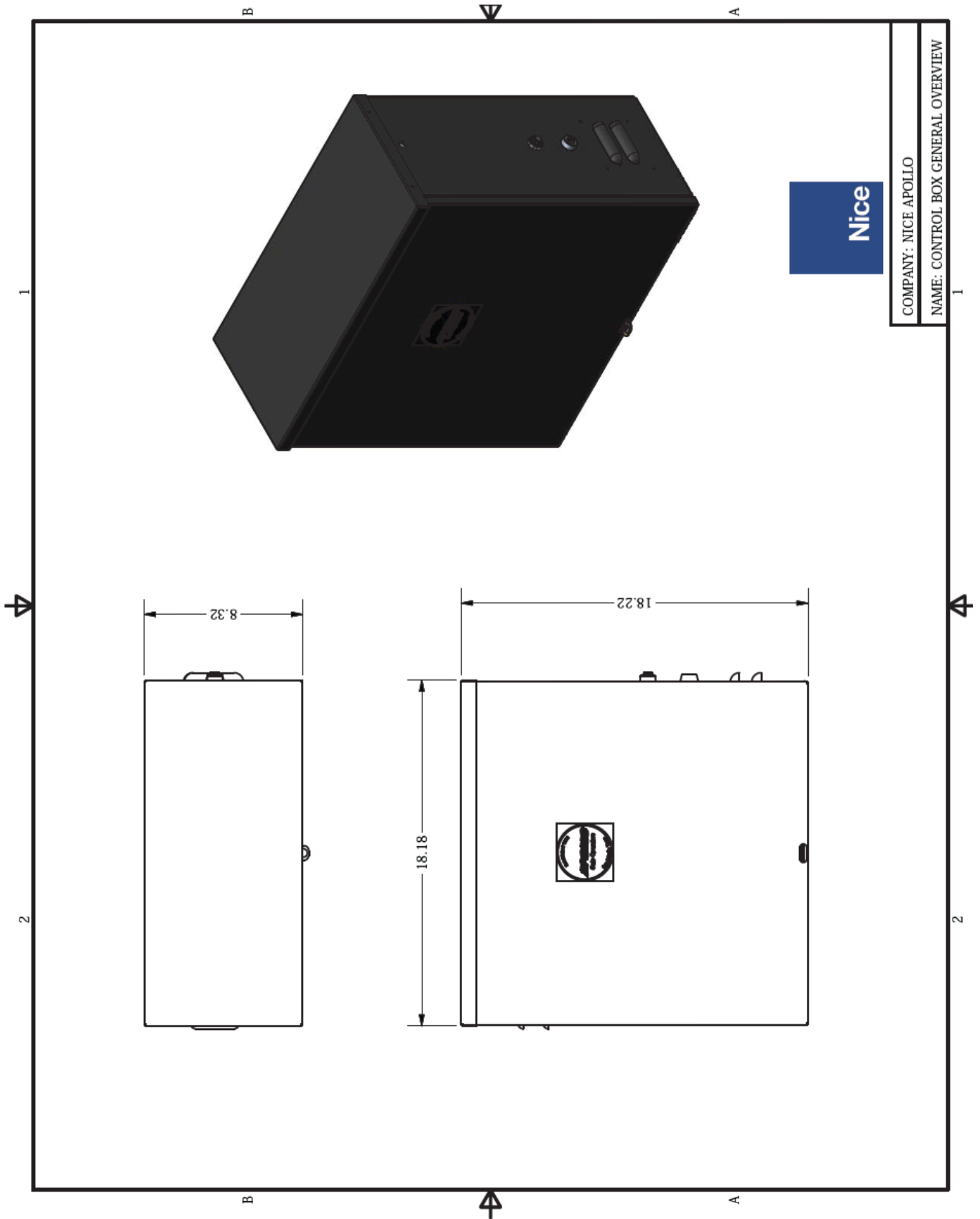

1500 LA Installation and Programming Manual

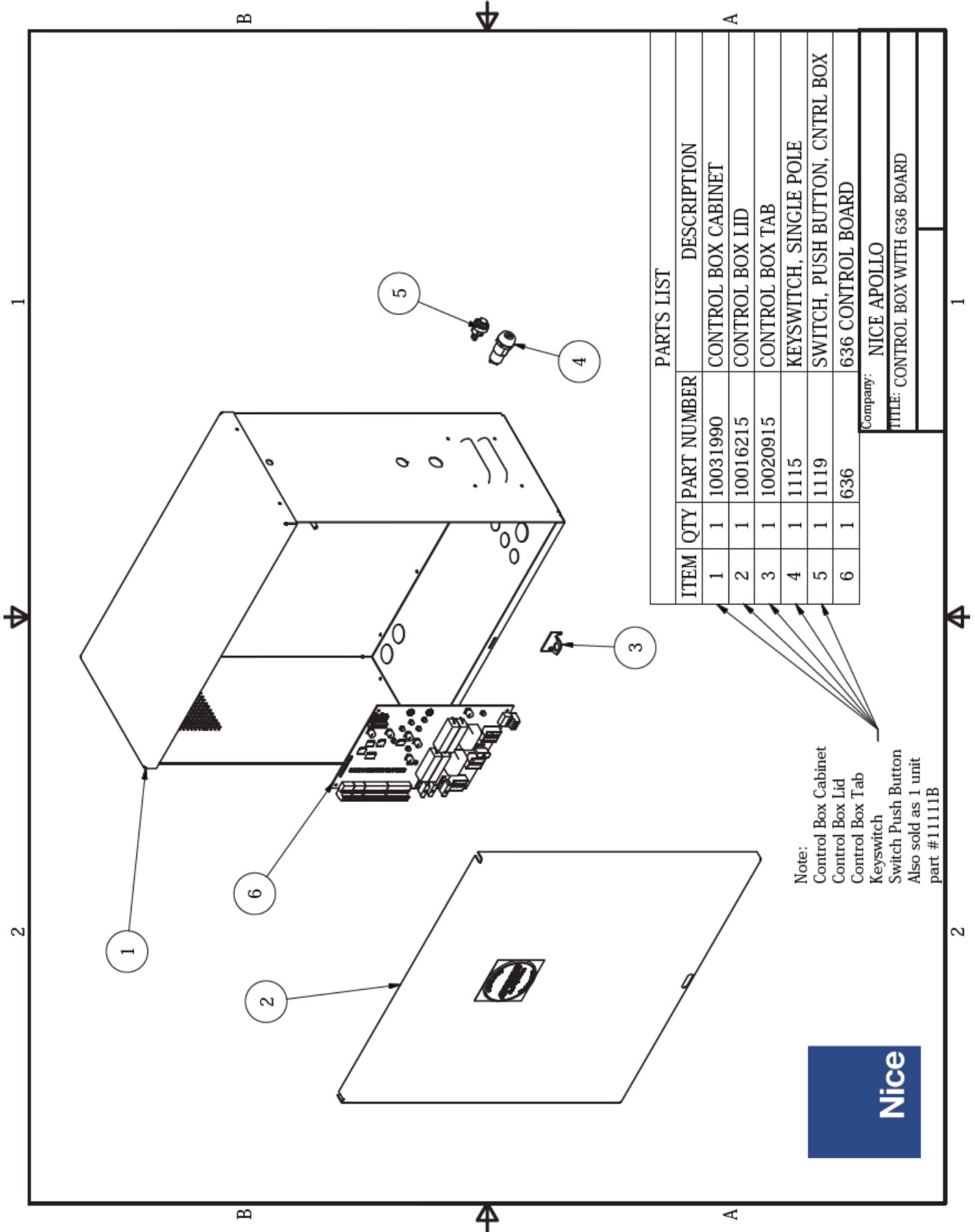

ITEM	QTY	PART NUMBER	DESCRIPTION
1	1	10031990	CONTROL BOX CABINET
2	1	10016215	CONTROL BOX LID
3	1	10020915	CONTROL BOX TAB
4	1	11115	KEYSWITCH, SINGLE POLE
5	1	11119	SWITCH, PUSH BUTTON, CNTRL BOX
6	1	636	636 CONTROL BOARD

Company: NICE APOLLO
 TITLE: CONTROL BOX WITH 636 BOARD

Note:
 Control Box Cabinet
 Control Box Lid
 Control Box Tab
 Keyswitch
 Switch Push Button
 Also sold as 1 unit
 part #11111B

1500 LA Installation and Programming Manual

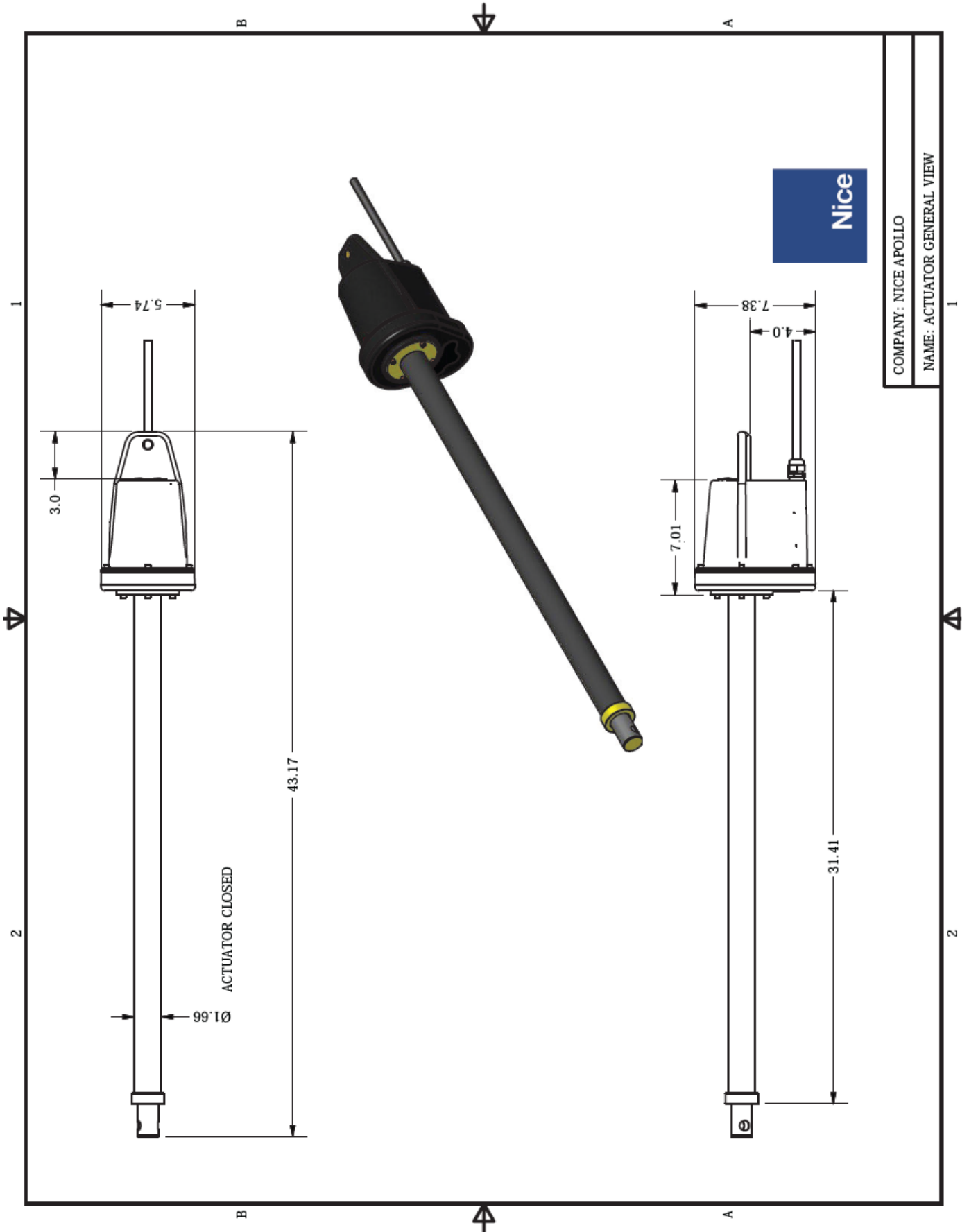

1500 LA Installation and Programming Manual

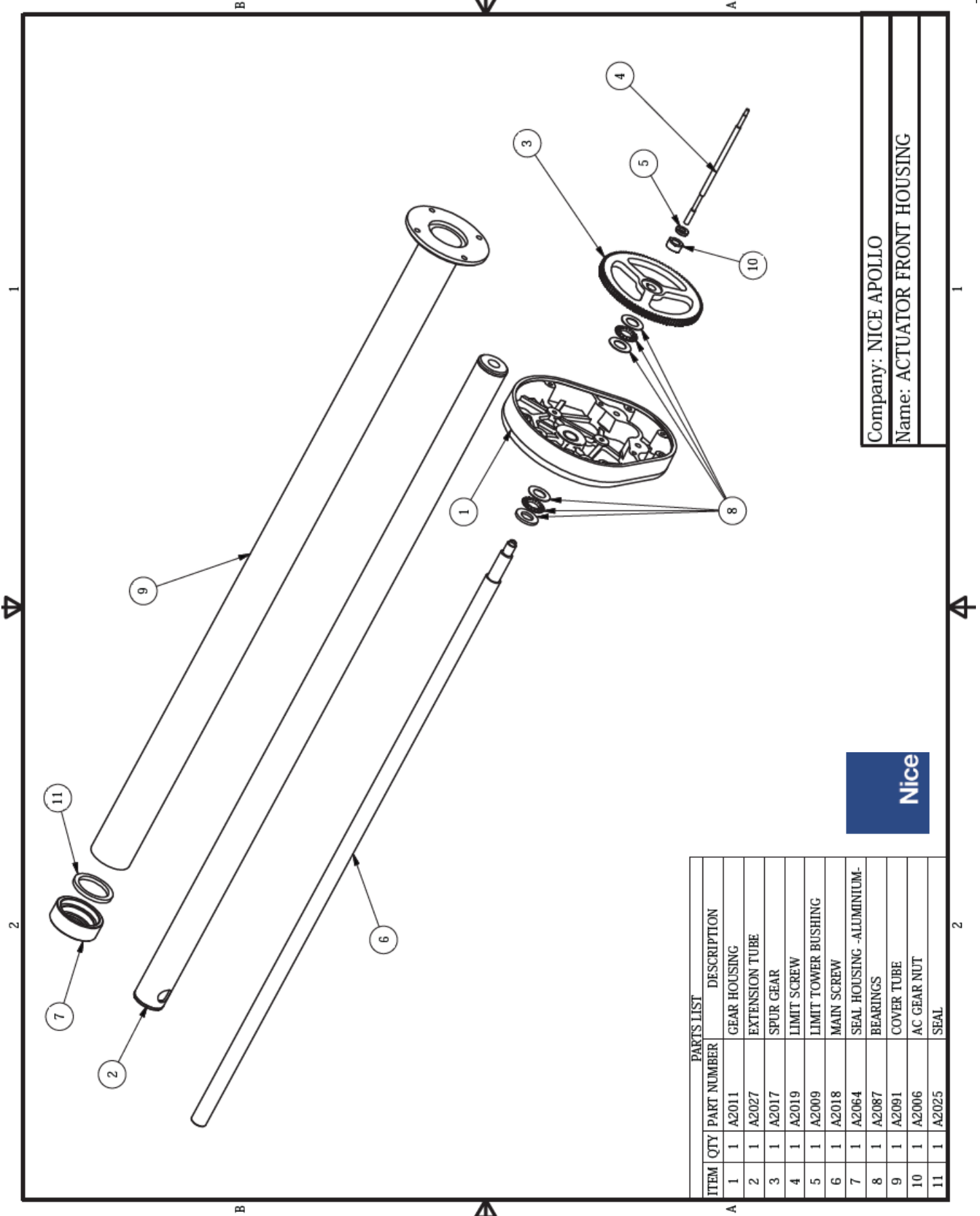

Company: NICE APOLLO
Name: ACTUATOR FRONT HOUSING



PARTS LIST	
ITEM	DESCRIPTION
1	GEAR HOUSING
2	EXTENSION TUBE
3	SPUR GEAR
4	LIMIT SCREW
5	LIMIT TOWER BUSHING
6	MAIN SCREW
7	SEAL HOUSING - ALUMINIUM-
8	BEARINGS
9	COVER TUBE
10	AC GEAR NUT
11	SEAL

1500 LA Installation and Programming Manual

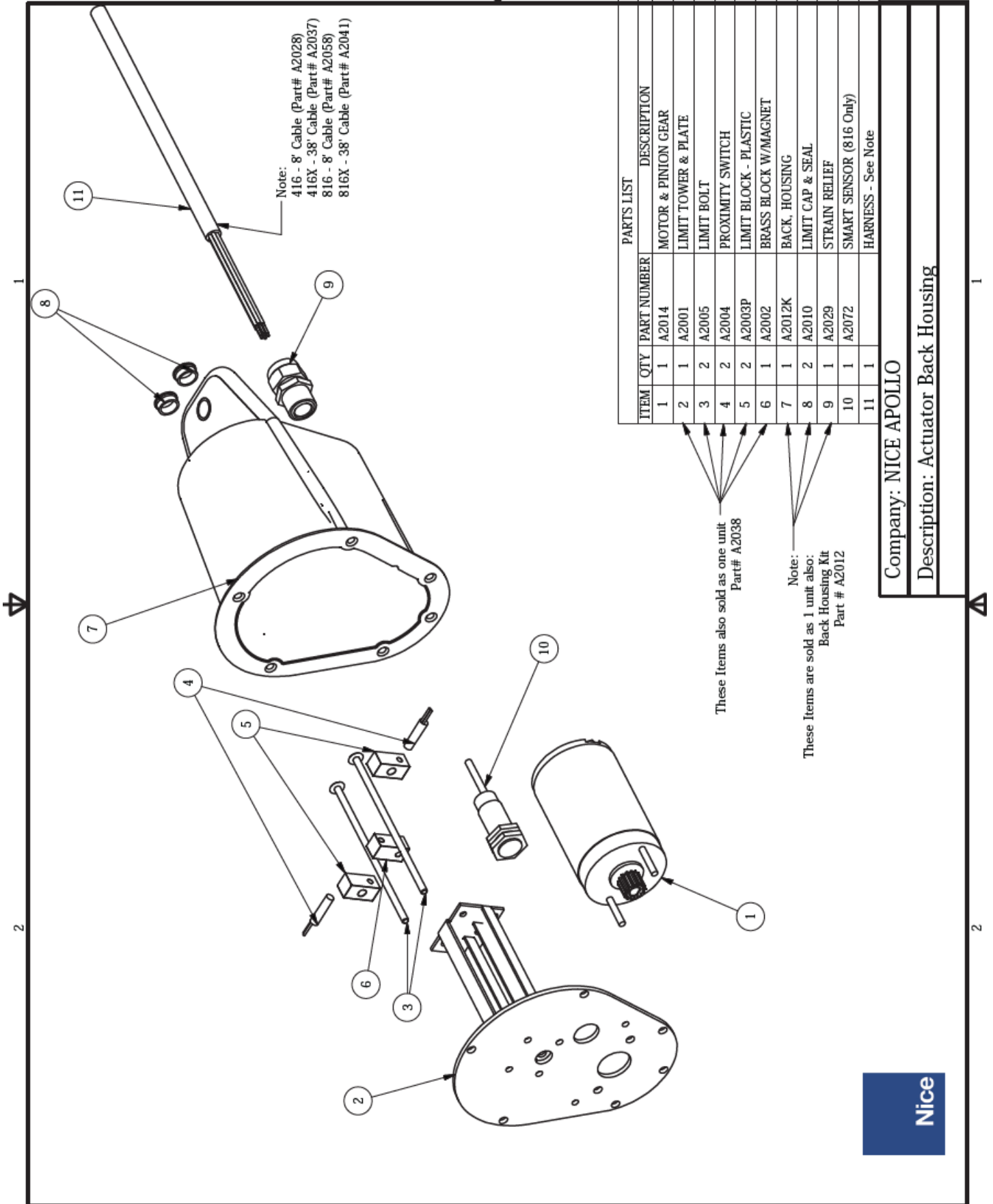

ITEM	QTY	PART NUMBER	DESCRIPTION
1	1	A2014	MOTOR & PINION GEAR
2	1	A2001	LIMIT TOWER & PLATE
3	2	A2005	LIMIT BOLT
4	2	A2004	PROXIMITY SWITCH
5	2	A2003P	LIMIT BLOCK - PLASTIC
6	1	A2002	BRASS BLOCK W/MAGNET
7	1	A2012K	BACK, HOUSING
8	2	A2010	LIMIT CAP & SEAL
9	1	A2029	STRAIN RELIEF
10	1	A2072	SMART SENSOR (816 Only)
11	1		HARNESS - See Note

These Items also sold as one unit
Part# A2038

Note:
These Items are sold as 1 unit also:
Back Housing Kit
Part # A2012

Company: NICE APOLLO

Description: Actuator Back Housing



1500 LA Installation and Programming Manual

SECTION 12: WARRANTY

1. Warranty. Nice North America LLC ("Nice") warrants that at the time of sale each Nice or HySecurity-branded gate operator ("Product") that it sells will, in all material respects, conform to its then applicable specification and will be free from defects in material and manufacture.

The following additional durational warranties apply to Nice or HySecurity branded Product, depending on whether (1) the Product is purchased through an authorized distributor and (2) whether a timely and complete Product registration is submitted to Nice.

It is therefore important that you register your Product with Nice, online at www.hysecurity.com/warranty, within the 60-day period described below.

1(a) Nice Products Purchased Through Authorized Distributors and Properly Registered

For any gate operator Product that is purchased from an authorized Nice distributor (this excludes Product purchased through internet resellers or any distributor not authorized by Nice), if the Product registration is completed by the Dealer/Installer or End User within 60 days of the date of purchase, the following warranty terms will apply. Nice warrants that the Product will remain serviceable under this warranty for the following periods:

- i) HySecurity brand hydraulic gate operator hydraulics, controls, and mechanical components: Five Years or 500,000 gate cycles (whichever occurs first) after the date of installation;
- ii) HySecurity hydraulic wedge operator hydraulics and controls: Five Years or 500,000 cycles (whichever occurs first) after the date of installation. Wedge mechanical components: Two Years after the date of installation;
- iii) Nice or HySecurity brand commercial grade electromechanical pad-mounted slide and swing operators such as SwingSmart 535 and SlideSmart 535: Five Years or 500,000 cycles (whichever occurs first) after the date of installation, except that commercial grade electromechanical pad-mounted slide and swing operators used for single family residential purposes shall have a warranty term of Seven Years after the date the product was shipped by Nice;
- iv) Nice brand residential grade pad mount swing and slide gate operators such as Juno and Vanguard 3501: Three years after the date of installation;
- v) Nice brand electromechanical linear actuator Swing operators: Three Years after the date of installation;
- vi) HySecurity electromechanical surface mount wedge operator electronics: Two Years or 500,000 gate cycles (whichever occurs first), after the date of installation;
- vii) Electromechanical barrier arm operators: Two years or 1,000,000 gate cycles (whichever occurs first) after the date of installation, provided that the preceding Five Year warranty period in (i), (ii), and (iii) above will not extend beyond seven years from the date that the product was shipped by Nice, and the Two Year warranty period in (ii), (iv), (v), and (vi) above will not extend beyond four years from the date that the product was shipped by Nice.

The preceding warranty durations do not apply to the products or components described below (viii-xi), which have a shorter warranty period:

- viii) Hydraulic gate operator drive wheels, including XtremeDrive™ wheels and rack: Two Years from date of installation;
- ix) AC and DC power supplies, chargers, and inverters: Two Years from date of installation, except batteries;
- x) Batteries: One Year from date of shipment by Nice;
- xi) Components subject to normal wear including, but not limited to, chains, belts, idler wheels, sprockets and fuses: One Year from date of installation.

1(b) Nice Products Not Purchased Through an Authorized Distributor or Not Properly Registered within 60 Days

For any Product that is not purchased from an authorized distributor or for which the Product registration was not completed by the Dealer/Installer/End User within sixty (60) days of the date of purchase, the following warranty will apply:

Nice warrants that the Product will remain serviceable under this warranty for the following periods, which begin on the date that the Product was shipped by Nice:

- i) All gate operators: One Year or 100,000 gate cycles, whichever occurs first.
- ii) AC and DC power supplies, chargers, or inverters: One Year from date of installation.
- iii) Hydraulic gate operator drive wheels: One Year from date of installation.

1(c) Replacement Parts

Nice warrants that replacement parts for Products (whether new or reconditioned) will remain serviceable under this warranty for One Year from the date that the part was shipped by Nice or the remaining period of the Product warranty, whichever is longer.

1(d) Limitations and Exclusions Applicable to Each of the Preceding Warranties.

The preceding warranties shall not apply to equipment that has been (1) installed, maintained, or used improperly or contrary to instructions; (2) subjected to

negligence, accident, vandalism, or damaged by severe weather, wind, flood, fire, terrorism or war; or (3) damaged through improper operation, maintenance, storage or abnormal or extraordinary use or abuse. Any modification made to products will void the warranty unless the modifications are approved in writing by Nice in advance of the modification (this exclusion does not apply to normal installation of approved accessories and/or protective devices or sensors). It is the responsibility of the Distributor, Dealer/Installer, or End User to ensure that the software version in the product is maintained to the latest revision level.

The preceding warranties do not extend to accessories when those items carry another manufacturer's name plate and are not a part of the base model. Nice disclaims all warranties for such accessory components, which carry only the original warranty, if any, of their original manufacturer. Nice hereby assigns its rights under such manufacturer warranties—to the extent that such rights exist and are assignable—to Buyer.

The warranties made by Nice herein extend to Nice's Distributors, to the Dealer/Installer, and to the first End User of the product following installation. They do not extend to subsequent purchasers.

The warranties herein do not apply to Mighty Mule-branded products and components.

2. Exclusion of Other Warranties.

The warranties contained in Section 1 are the exclusive warranties given by Nice and supersede any prior, contrary or additional representations, whether oral or written. Any prior or extrinsic representations or agreements are discharged or nullified. NICE HEREBY DISCLAIMS AND EXCLUDES ALL OTHER WARRANTIES—WHETHER EXPRESS, IMPLIED, OR STATUTORY—INCLUDING ANY WARRANTY OF MERCHANTABILITY, ANY WARRANTY OF FITNESS FOR A PARTICULAR PURPOSE, ANY LIABILITY FOR INFRINGEMENT, AND ANY WARRANTIES OTHERWISE ARISING FROM COURSE OF DEALING, COURSE OF PERFORMANCE, OR USAGE OF TRADE.

3. Buyer's Exclusive Remedies for Any Nonconformity.

If a Nice Product fails to conform to the warranties in Section 1, Buyer must notify and order replacement parts from the Distributor through which the Product was purchased within a reasonable time and in no event more than thirty (30) days after the discovery of the nonconformity. Nice will investigate and, in the event of a breach, will provide, within a reasonable period of time, one of the following remedies to be selected by Nice in its sole and absolute discretion:

- (1) repair or replacement of any nonconforming Products or Product components or
- (2) refund of the price upon return of the nonconforming items. Nice reserves the right to supply used or reconditioned material for all warranty claims. Nice will not be considered to be in breach of or default under this Warranty because of any failure to perform due to conditions beyond its reasonable control, including any force majeure event. This warranty does not cover any incidental expenses, including fines or penalties, temporary security, labor, shipping, travel time or standby time that are incurred for inspection or replacement of any nonconforming items. As a condition of warranty coverage, warranty claims must be submitted in accordance with the procedures described on the Nice form, "RMA Procedures." THE REMEDY SELECTED BY NICE IN ACCORDANCE WITH THIS PARAGRAPH SHALL BE THE EXCLUSIVE AND SOLE REMEDY OF BUYER FOR ANY BREACH OF WARRANTY.

4. Exclusion of Consequential and Incidental Damages.

NICE SHALL NOT BE LIABLE FOR ANY INCIDENTAL, SPECIAL, OR CONSEQUENTIAL DAMAGES, WHETHER RESULTING FROM NONDELIVERY OR FROM THE USE, MISUSE, OR INABILITY TO USE THE PRODUCT OR FROM DEFECTS IN THE PRODUCT OR FROM NICE'S OWN NEGLIGENCE. This exclusion applies regardless of whether such damages are sought for breach of warranty, breach of contract, negligence, or strict liability. This exclusion does not apply to claims for bodily injury or death.

5. Severability.

If any provision of this warranty is found to be invalid or unenforceable, then the remainder shall have full force and effect.

6. Proprietary Rights.

Nice retains and reserves all right, title, and interest in the intellectual property rights of its products, including any accompanying proprietary software. No ownership of any intellectual property rights in the products or accompanying software is transferred to Distributor, Dealer/Installer, or End User.

7. Applicable Law.

This warranty will be interpreted, construed, and enforced in all respects in accordance with the laws of the State of Washington, without reference to its choice of law principles. The U.N. Convention on Contracts for the International Sale of Goods will not apply to this warranty.

1500 LA Installation and Programming Manual

INSTALLATION INFORMATION AND SIGN-OFFS

Installation Acceptance

Address where opener is located

Installer name, number and address

End user name and telephone number

Contact Information: Visit <https://hysecurity.com/technical-support/> for installation manuals, replacement part instructions, part diagrams and more. Qualified HySecurity distributors are experienced and trained to assist in resolving installation problems. For the name of a qualified distributor near you, call HySecurity at 800-321-9947. *Before contacting your distributor or HySecurity Technical Support, obtain the serial number of your operator.

1500 LA

Installation and Programming Manual

Customer Service

760-438-7000

Monday – Friday, 5:00 a.m. – 4:00 p.m. PST

Nice North America LLC

5919 Sea Otter Place, Suite 100

Carlsbad, CA 92010

The logo consists of a solid black square with the word "Nice" written in white, bold, sans-serif font inside it.

Nice

Niceforyou.com