

SwingSmart™ 535

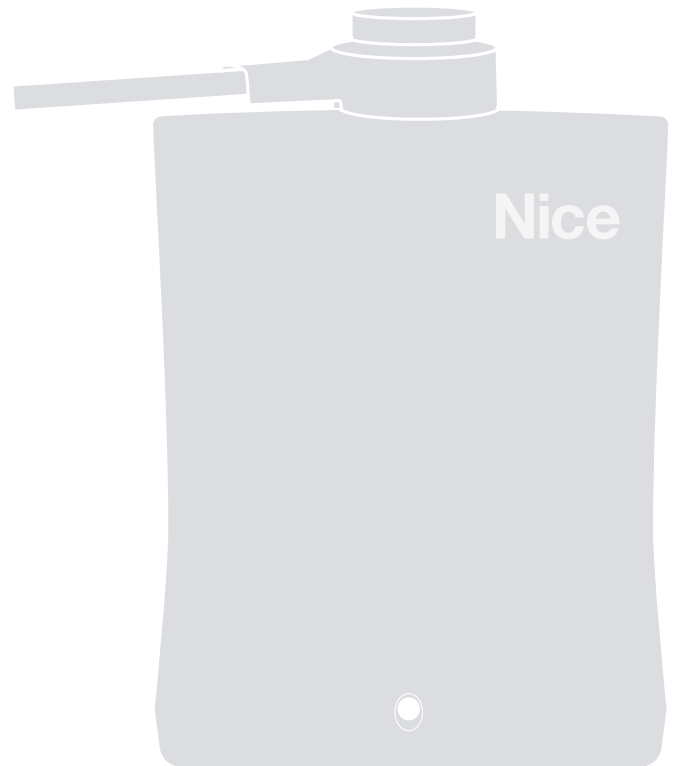

Swing Gate Operator

Installation and Programming Manual

Nice

Table of Contents

SwingSmart 535

Table of Contents	2	Connect to The HySecurity Installer App	37
Safety Requirements	3 - 10	Maintenance	38
Features	11	Firmware Updates and Debug Data	39
Unpack the Operator	12	Troubleshooting/Alerts/Faults/Errors	40 - 46
Operator Position	13	Appendix A - Vehicle Detector Loops	47 - 48
Prepare an Installation Site	14 - 15	Appendix B - French Translations	49 - 52
Install Arm Assembly	16 - 17	Warranty	54
Install and Adjust the Limit Sensors	18 - 19	Specifications	55
Attach Back Cover	20		
Attach Top Cap and Adjust Taper Clamp	21		
Wiring and Power	22 -23		
Controller Connections	24		
User Interface	25		
Initial Setup	26		
Operator Configurations	27		
Bi-Parting Gate Setup	28		
Controller Inputs	29		
Entrapment Sensor Wiring - BlueBUS	30		
Entrapment Sensor Wiring	31		
List of Entrapment Sensors	32		
Set IES Sensitivity	33		
SmartTouch 725 - Hy5B Module	34		
Relay Outputs - Basic	35		
OXI MegaCode Installation & Programming	36		

For Installation manuals, replacement part instructions, part diagrams and more visit support.hysecurity.com.

The Advanced Manual is available in digital form at the link above and physical copies from distributors. It includes additional information about the SwingSmart 535. For example, the HySecurity installer app, menu options, installation configurations, solar installations, I/O expansion board, external entrapment sensors, loop detectors, maintenance, and more.

Safety Requirements

SAFETY MESSAGES

The safety messages below inform you about potential hazards that can result in injury. Safety messages specifically address level of exposure to operator and are preceded by one of four words: DANGER, WARNING, CAUTION or NOTICE.

DANGER

Indicates a hazardous situation which, if not avoided, **WILL** result in **DEATH** or **SERIOUS INJURY**.

WARNING

Indicates a hazardous situation which, if not avoided, **COULD** result in **DEATH** or **SERIOUS INJURY**.

CAUTION

Indicates a hazardous situation which, if not avoided, **COULD** result in **MINOR** or **MODERATE INJURY**.

NOTICE

Addresses practices not related to personal injury. Indicates damage to equipment is probable if the hazardous situation is not avoided.

COMMON INDUSTRIAL SYMBOLS

These international safety symbols may appear on product or in its literature to alert of potential personal injury hazards. Obey all safety messages that follow these symbols to avoid possible injury or death.

Symbol	Safety Hazard
	Attention - Take Notice
	Danger - Keep Away
	Entrapment Zone
	Possible Pinch Point

Safety Requirements

IMPORTANT SAFETY INSTRUCTIONS

Hazards, associated with automatic gates, can be reduced with proper site design, installation, and use. Installers, maintenance crews, and owners/users must read and follow the safety requirements found in Nice® product manuals.



It is important that only qualified installers handle installation of HySecurity Gate vehicular gate operators. A “qualified” installer has one of the following:



1. A minimum of three years experience installing similar equipment.
2. Proof of attending a HySecurity Technical Training seminar within the past three years.
3. Significant manufacturer endorsements of technical aptitude in gate operator installation and operation.

Underwriter Laboratories (UL) and the American Society for Testing and Materials (ASTM) are responsible for current safety standards and regulations regarding gate operators and automated gates. All aspects of gate installation must comply with the appropriate safety standard. For the most up-to-date ASTM F2200 Gate and Fence Standards, refer to www.astm.org. For UL 325 Safety Standard, refer to www.ul.com. Consult local government agencies for up-to-date rules and regulations as certain municipalities have established licensing, codes or regulations that regulate automated gate system design and installation.

GENERAL SAFETY INFORMATION

A gate operator is only a component in a gate system. The other parts of the gate system can include the gate, the external safety sensors, access controls, and vehicle detectors. To have a gate system that provides for safety, security, and reliable operation it is essential these components operate together as a system. It is the responsibility of the system designer and/or installer to ensure any safety or operational issues have been addressed.

WARNING

To reduce the risk of injury or death:

1. READ AND FOLLOW ALL INSTRUCTIONS.
2. Never let children operate or play with gate controls. Keep the remote control away from children.
3. Always keep people and objects away from the gate. **NO ONE SHOULD CROSS THE PATH OF THE MOVING GATE.**
4. Test the gate operator monthly. The gate **MUST** reverse on contact with a rigid object or stop when an object activates the non-contact sensors. After adjusting the force or the limit of travel, retest the gate operator. Failure to adjust and retest the gate operator properly can increase the risk of injury or death.
5. Use the manual release only when the gate is not moving.
6. **KEEP GATES PROPERLY MAINTAINED.** Read the user's manual. Have a qualified service person make repairs to gate hardware.
7. The entrance is for vehicles only. Pedestrians must use separate entrance.
8. **SAVE THESE INSTRUCTIONS.**

Safety Requirements

IDENTIFYING GATE OPERATOR CATEGORY AND UL 325 USAGE CLASS

The UL 325 standard covers gate operators. Within this safety standard several Usage Classes are described that define different types of installations where gate operators can be applied. Some operators are restricted in their usage application. Appropriate Usage Classes are shown in the Specifications.

Class I



Class I: Intended for use in a location of one to four single family dwellings or a parking area associated with one to four single family dwellings.

Class II



Class II: Intended for use in a commercial location or building such as a multi-family housing units (five or more single family units) hotels, garages, retail stores or other buildings servicing general public.

Class III

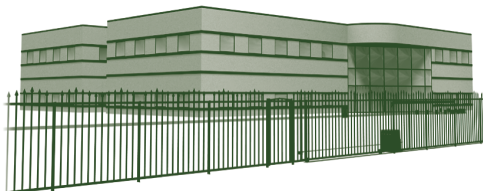

Class III: Intended for use in an industrial location or building such as factories or loading docks or other locations not accessible by the general public.

Class IV

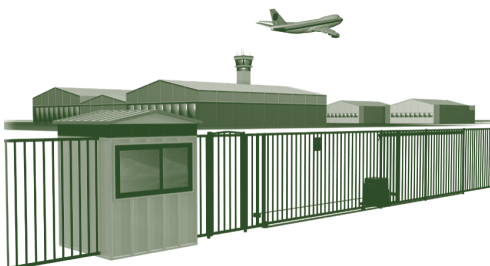

Class IV: Intended for use in guarded industrial locations or buildings such as an airport security area or other restricted access location, not servicing general public, in which access is monitored by security personnel or via closed circuitry.

Safety Requirements

WARNING

This automatic gate operator is not designed nor is it intended for pedestrian traffic. Vehicular gate operators must by their nature be powerful to function reliably. This power can cause injury or death. Accordingly, direct all pedestrian traffic to a separate walk-through gate.

VEHICULAR TRAFFIC ONLY

Install this gate operator only when:

- The operator is appropriate for the construction of the gate and the usage Class of the gate.
- All openings of a horizontal slide gate are guarded or screened from the bottom of the gate to a minimum of 1.83 m (6 ft) above the ground to prevent a 57.2 mm (2-1/4 in) diameter sphere from passing through the openings anywhere in the gate, and in that portion of the adjacent fence that the gate covers in the open position.
- All exposed pinch points are eliminated or guarded.
- Guarding is supplied for exposed rollers.

The operator is intended for installation only on gates used for vehicles. Pedestrians must be supplied with a separate access opening. The pedestrian access opening shall be designed to promote pedestrian usage. Locate the gate such that persons will not come in contact with the vehicular gate during the entire path of travel of the vehicular gate.

The gate must be installed in a location so that enough clearance is supplied between the gate and adjacent structures when opening and closing to reduce the risk of entrapment. Swinging gates shall not open into public access areas.

The gate must be properly installed and work freely in both directions prior to the installation of the gate operator. Do not over-tighten the operator clutch or pressure relief valve to compensate for an improperly installed, improperly functioning, or damaged gate.

Permanently mounted controls intended for user activation must be located at least 1.83 m (6 ft) away from any moving part of the gate and where the user is prevented from reaching over, under, around or through the gate to operate the controls.

- Exception: Emergency access controls only accessible by authorized personnel (e.g. fire, police, EMS) may be placed at any location in the line-of-sight of the gate.

The Stop and/or Reset button must be located in the line-of-sight of the gate. Activation of the reset control shall not cause the operator to start.

A minimum of two (2) WARNING SIGNS shall be installed, in the area of the gate. Each placard is to be visible by persons located on the side of the gate on which the placard is installed.

For gate operators utilizing a non-contact sensor (Photo Eye):

- See instructions on the placement of non-contact sensors for each type of application.
- Care shall be exercised to reduce the risk of nuisance tripping, such as when a vehicle trips the sensor while the gate is still moving.
- One or more non-contact sensors shall be located where the risk of entrapment or obstruction exists, such as the perimeter reachable by a moving gate or barrier.

For a gate operator utilizing a contact sensor (Edge):

- One or more contact sensors shall be located where the risk of entrapment or obstruction exists, such as at the leading edge, trailing edge, and postmounted both inside and outside of a vehicular horizontal slide gate.
- A hardwired contact sensor shall be located and its wiring arranged so that the communication between the sensor and the gate operator is not subjected to mechanical damage.
- A wireless device such as one that transmits radio frequency (RF) signals to the gate operator for entrapment protection functions shall be located where the transmission of the signals are not obstructed or impeded by building structures, natural landscaping or similar obstruction. A wireless device shall function under the intended end-use conditions.
- One or more contact sensors shall be located on the inside and outside leading edge of a swing gate. Additionally, if the bottom edge of a swing gate is greater than 152 mm (6 in) but less than 406 mm (16 in) above the ground at any point in its arc of travel, one or more contact sensors shall be located on the bottom edge.

USE OF VEHICLE DETECTORS

Use of vehicle detectors (loop detectors) is strongly encouraged to prevent damage to vehicles caused by gates closing on them. This is not considered to be a safety item as vehicle detectors cannot provide protection to pedestrians. In some situations, photoelectric devices may be used as vehicle detectors, but should be wired accordingly.

Safety Requirements

GATE CONSTRUCTION AND SAFETY

Gate construction plays a very important role in ensuring the safety of any automated gate system. The standard for gate construction is ASTM F2200. Below are key areas to address in gate design for safety. For complete information consult the standard. Copies of the standard are available at:

<https://www.astm.org/Standards/F2200.htm>.

Another source of information is available from DASMA, the Door and Access System Manufacturer's Association. The Association publishes Technical Data Sheets, one of which concerns ASTM F2200. For more information, see:

<http://www.dasma.com/PDF/Publications/TechDataSheets/OperatorElectronics/TDS370.pdf>.

General Requirements for gate construction:

- Gates shall be constructed in accordance with the provisions given for the appropriate gate type listed. Refer to ASTM F2200 for additional gate types.
- Gates shall be designed, constructed and installed to not fall over more than 45 degrees from the vertical plane, when a gate is detached from the supporting hardware.
- Gates shall have smooth bottom edges, with vertical bottom edged protrusions not exceeding 0.50 in (12.7 mm) other than the Exceptions listed ASTM F2200.
- The minimum height for barbed wire shall not be less than 6 ft (1.83 m) above grade. The minimum height for barbed tape shall not be less than 8 ft (2.44 m) above grade.
- An existing gate latch shall be disabled when a manually operated gate is retrofitted with a powered gate operator.
- A gate latch shall not be installed on an automatically operated gate.
- Protrusions shall not be permitted on any gate. Consult ASTM F2200 for exceptions.
- Gates shall be designed, constructed and installed such that their movement shall not be initiated by gravity when an automatic operator is disconnected.
- For pedestrian access in the vicinity of an automated vehicular gate, a separate pedestrian gate shall be provided. The pedestrian gate shall be installed in a location such that a pedestrian shall not come in contact with a moving vehicular access gate. A pedestrian gate shall not be incorporated into an automated vehicular gate panel.
- Any non-automated gate that is to be automated shall be upgraded to conform to the provisions of this specification.
- This specification shall not apply to gates generally used for pedestrian access and to vehicular gates not to be automated.

The following provisions shall apply to Class I, Class II, Class III, and Class IV vehicular horizontal slide gates:

All weight bearing exposed rollers 8 ft (2.44 m), or less, above grade shall be guarded or covered.

All openings shall be designed, guarded, or screened from the bottom of the gate to the top of the gate or a minimum of 72 inch (1.83 m) above grade, whichever is less, to prevent a 2-1/4 inch (57 mm) diameter sphere from passing through the openings anywhere in the gate, and in that portion of the adjacent fence that the gate covers in the open position. The gate panel shall include the entire section of the moving gate, including any back frame or counterbalance portion of the gate.

A gap, measured in the horizontal plane parallel to the roadway, between a fixed stationary object nearest the roadway (such as a gate support post) and the gate frame when the gate is in either the fully open position or the fully closed position, shall not exceed 2-1/4 inches (57 mm).

- Exception: All other fixed stationary objects greater than 16 inches (406 mm) from the gate frame shall not be required to comply with this section.

Positive stops shall be required to limit travel to the designed fully open and fully closed positions. These stops shall be installed at either the top of the gate, or at the bottom of the gate where such stops shall horizontally or vertically project no more than is required to perform their intended function.

All gates shall be designed with sufficient lateral stability to assure that the gate will enter a receiver guide. Consult ASTM F2200 for details on various gate panel types.

Safety Requirements

- Any existing automated gate, when the operator requires replacement, shall be upgraded to conform to the provisions of this specification in effect at that time.

MAINTENANCE OF GATE SYSTEMS

To keep your automated gate system performing both safely and reliably it is important to ensure that the components of that system are functioning properly.

At least monthly:

- Disconnect the gate operator and manually move the gate through its range of travel. Note any squeaks from rollers or hinges or areas of binding. The gate should travel smoothly and quietly throughout its range. If it does not, contact a gate professional to correct the problem.
- Reconnect the gate operator and perform the following tests:
 - With the gate opening, block any photo eyes and/or depress any safety edges used to protect the open direction. The gate should stop and/or reverse.
 - With the gate closing, block any photo eyes and/or depress any safety edges used to protect the close direction. The gate should stop and/or reverse.
 - Using a suitable obstruction in the path of the gate (a solid, immovable object), run the gate in the open direction until it contacts the obstruction. The gate should stop and reverse.
 - Using a suitable obstruction in the path of the gate (a solid, immovable object), run the gate in the close direction until it contacts the obstruction. The gate should stop and reverse.

ENTRAPMENT PROTECTION

The UL 325 standard for gate operators requires a minimum of two independent entrapment protection means for each entrapment zone.

An entrapment zone is defined as follows:

For swing gates, locations between a moving gate or moving, exposed operator components and a counter opposing edge or surface where entrapment is possible up to 6 ft (1.83 m) above grade. Such locations occur if during any point in travel:

- The gap between the bottom of a moving gate and the ground is greater than 4 inches (101.6 mm) and less than 16 inches (406 mm); or
- The distance between the center line of the pivot and the end of the wall, pillar, or column to which it is mounted when in the open or closed position exceeds 4 inches (101.6 mm). Any other gap between a moving gate and fixed counter opposing edges or surfaces or other fixed objects is less than 16 inches (406 mm) (examples are walls, curbs, berms or other immovable objects).

All Nice gate operators feature an Inherent Entrapment System (IES) (UL 325 Type A) that monitors the force on the gate during travel. This system protects in both the open and close direction and reverses on contact with an obstruction. The IES serves as one of the means of entrapment protection.

Potential entrapment zones are shown on the next page for swing gates, but keep in mind there may be other entrapment zones presented by the actual installation and adjacent structures or landscape that must be protected as well. External sensors must be used to protect against entrapment at each location where an entrapment zone exists. The minimum number of external sensors required to enable automatic operation of the gate operator is as follows:

- Swing Gates: One external sensor in the direction where an entrapment zone exists (provided there is no risk of entrapment in the other direction).

The gate operator tests for the presence of these sensors, and if the required minimum number is not found, the operator will only run using continuous pressure on an Open/Close button, either on the controller, or an external device.

Safety Requirements

Installers must identify all potential entrapment zones and install sensors that protect these areas.

Review your installation plan for entrapment zones. Install entrapment sensors anywhere within the motion of the gate or gate operator where it has a clearance less than 16 inch (41 cm).

Swing Gate Potential Entrapment Zones

1. Leading Edge
2. Bottom Edge
3. Entry / Exit
4. Posts
5. Post Pivot / Pinch Points
6. Arm Movement

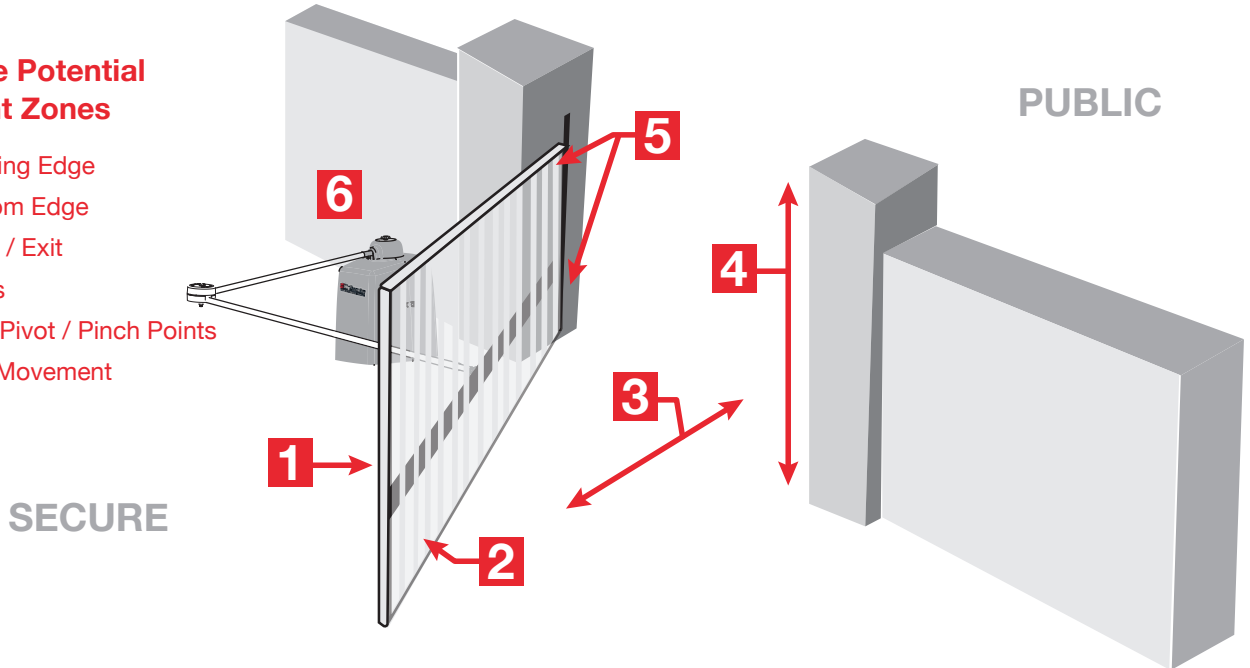

SWING GATE OPEN POSITION ENTRAPMENT ZONES

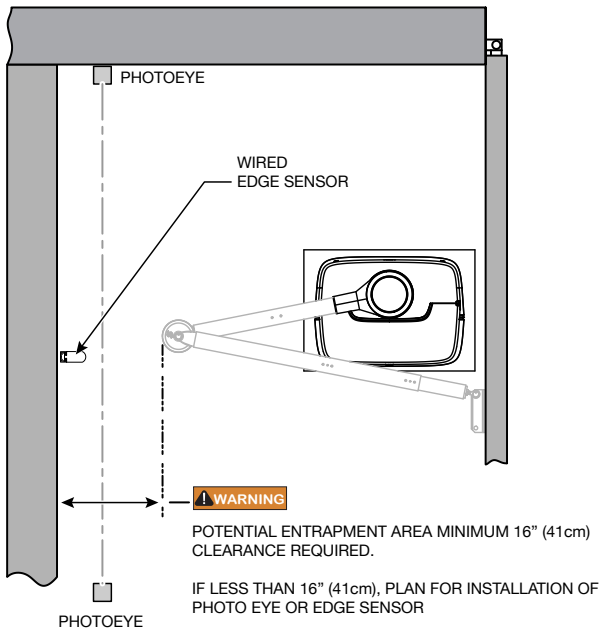

Safety Requirements

STOP BUTTON

The stop button clears entrapment mode and resets some faults, errors, and alerts.

The stop button on 535 family of operators is located on the cover.

Press the stop button while the gate is opening or closing to stop gate travel and disable the automatic close timer. The operator requires a new open or close command to resume function.

Inform all users of the location of the stop button and its function.

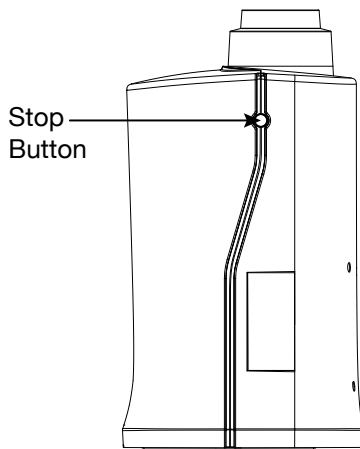

Figure 1. External Stop Button

MANUAL RELEASE

Teach all users how to turn off electric power, loosen the taper clamp, and move the gate manually.

When you set DC power to OFF:

- The motor disengages to stop it from running if an open or close input is activated
- The Motor Switch Off warning appears on the display

To manually open the gate, follow these steps:

1. Use the key to remove the top cap and the front cover.
2. Set the DC switch to OFF.
3. Loosen the taper clamp (Figure 2).
4. Swing the gate(s) open or close from the end of the gate.

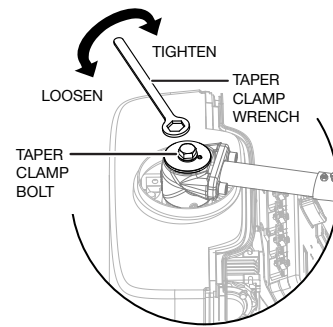

Figure 2. Taper Clamp Bolt and Taper Clamp Wrench

To return SwingSmart to automatic operation, follow these steps:

1. Set the taper clamp. Refer to "Set the Taper Clamp" on page 21.
2. Set the DC power switch to ON.
3. Press STOP or RESET to clear any faults.
4. Attach the front cover and top cap.

Features

INTELLIGENT FEATURES: SmartTouch 725™ Controller

HySecurity installer smartphone app for full control from your phone via Bluetooth.

Save operator configurations and troubleshoot system via installer smartphone app or USB.

User Interface – The SmartTouch 725 controller manages 70+ configurable items in a simple menu driven interface. The controller includes a library of dozens of solutions for relay logic applications.

Three configurable user relays plus optional SmartTouch I/O Expansion module for 8 additional relay outputs.

OLED display – A 32-character OLED provides increased readability for programming and troubleshooting.

Independent adjustment for open and close gate speeds - An easy-to-use menu on the SmartTouch 725 Controller allows the installer to independently vary the open and close speed settings.

Intelligent Inherent Entrapment Sensor (IES) - Any impediment to gate travel is sensed by the system, stopping gate movement per UL 325 Safety Standards. The intelligent system monitors gate power then adapts the IES to trip at an adjustable threshold above normal power.

Hy5B™ 2.0 vehicle detector – Four ports for HySecurity Hy5B 2.0 vehicle detectors, enabling advanced features like automatic gate compensation and loop diagnostics.

Integrated HyNet™ technology provides remote management capabilities over Ethernet: Securely report gate system status, vehicle tailgating, gate hits, failure to operate, and more, in real time to maintain perimeter security. Additionally, configure email alerts to communicate issues to installer, facility or security responders.

Compatible with Nice accessories. OXI MegaCode receiver, ERA and INTI transmitters and BlueBUS photo eyes.

Unpack the Operator

UNPACK THE OPERATOR

1. Open the box and remove the front cover, rear cover, photo eye, and ship-with kit.
2. Check the contents of the ship-with kit:
 - a. Basic Manual
 - b. UL 325 required gate safety signs and zip ties
 - c. Taper clamp wrench
 - d. DASMA gate safety literature
 - e. Rear cover mounting hardware
 - f. Cover keys
 - g. Top cap, top cap shield, and zip ties
 - h. Optional 208/230VAC and 24VDC voltage labels
3. Lift operator using lift handles.

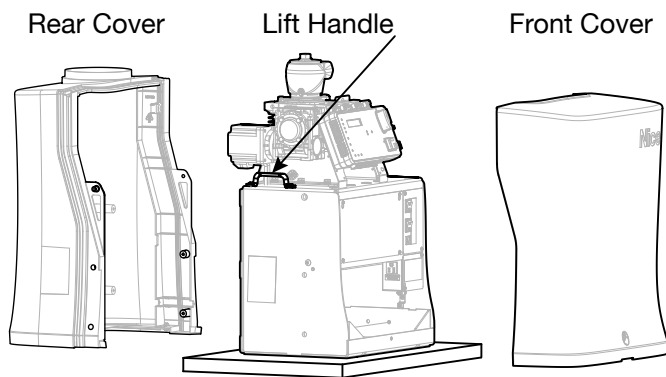

GENERAL OPERATOR DIMENSIONS

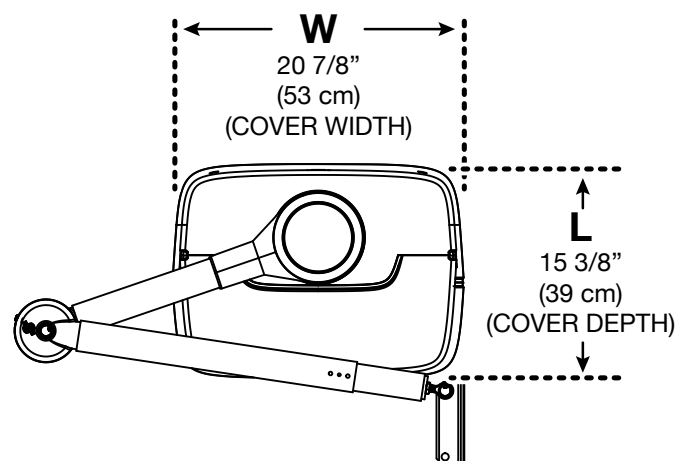
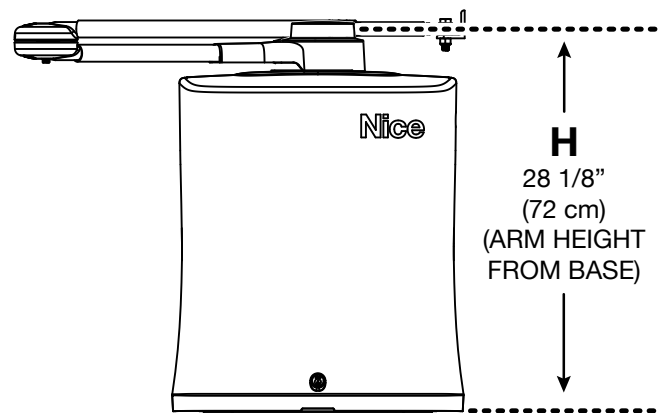

Note: You can mark the slots, conduit area, and output shaft center on the plywood underneath the chassis and then use the plywood as an anchor hole template.

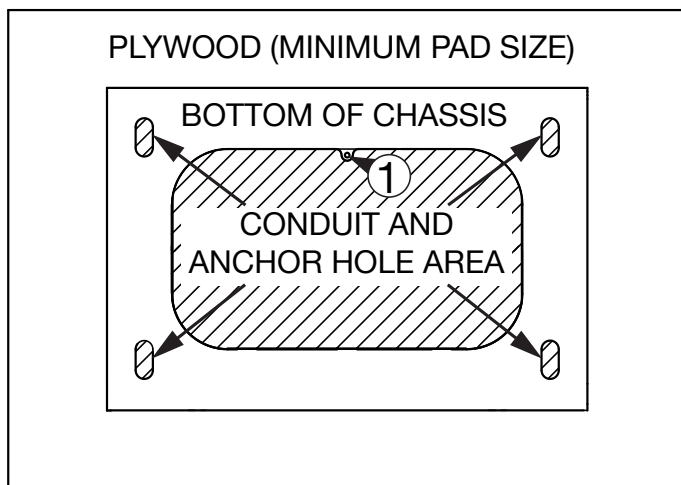

① OUTPUT SHAFT CENTER

Operator Position

NEW INSTALLATION

1. Make sure the pad is completely level before installation.
2. Determine the location of the operator from the gate hinge (Figure 3).
3. Refer to Table 1, Table 2, and the installation site for ideal operator and gate bracket locations.
4. Position the output shaft center at X and Y dimensions from the gate hinge.
5. Refer to Figure 4 for minimum dimensions for a new concrete pad. Refer to Figure 6 for conduit and earth ground requirements.
6. Mark Xg on the gate and mark the anchor hole positions on the concrete pad (Figure 3, Figure 5).
7. Remove the operator and drill holes for four 1/2 inch UNC x 3-1/2 inch wedge style anchors.
8. Install the anchor bolts, mount the operator on the bolts, check the level, and shim as necessary.
9. Put a heavy duty flat washer on each bolt, and tighten the anchor-bolt nuts.
10. Bury the earth ground rod and connect earth ground wire to the chassis ground lug.

RETROFIT INSTALLATION

1. Remove any existing operator and anchor bolts.
2. Check the level of the concrete pad and level it if needed.
3. Position the new SwingSmart 535 operator around the conduit.
4. Mark the new anchor locations (Figure 5).
5. Remove the operator and drill holes for four 1/2 inch UNC x 3-1/2 inch wedge style anchors.
6. Install the anchor bolts, mount the operator on the bolts, put a heavy duty flat washer on each bolt, and tighten the anchor-bolt nuts.
7. Measure X and Y from the output shaft center and use Table 3 to calculate Xg, A, and B.
8. Mark Xg on the gate (Figure 3).
9. Route the earth ground wire and connect it to the earth ground lug.

Note: Use these tables as a starting point. Test gate movement and adjust the arm dimensions to achieve proper geometry.

Short/Medium Gate Installation for Gates up to 13 feet (4 meters)

X	Y	Xg	A	B
12.0 in (30.5 cm)	22.0 in (56 cm)	33.0 in (84 cm)	21.0 in (53 cm)*	28.0 in (71 cm)*
12.0 in (30.5 cm)	24.0 in (61 cm)	35.0 in (89 cm)	22.0 in (56 cm)*	30.0 in (76 cm)*
12.0 in (30.5 cm)	28.0 in (71 cm)	39.0 in (99 cm)	24.5 in (62 cm)*	33.5 in (85 cm)*

*Section of pivot arm must be cut to achieve geometry. Top cap requires 6 in (15 cm) of smaller diameter tube exposed.

Long Gate Installation for Gates up to 20 feet (6 meters)

X	Y	Xg	A	B
16.0 in (38 cm)	32.0 in (81 cm)	47.0 in (119 cm)	29.0 in (74 cm)*	40.5 in (103 cm)
16.0 in (38 cm)	36.0 in (91 cm)	51.0 in (130 cm)	32.0 in (81 cm)	43.0 in (109 cm)
16.0 in (38 cm)	40.0 in (102 cm)	56.0 in (142 cm)	35.5 in (90 cm)	46.0 in (117 cm)

*Section of pivot arm must be cut to achieve geometry. Top cap requires 6 in (15 cm) of smaller diameter tube exposed.

Custom Gate Installation

X	Y	Xg	A	B
—	—	$X + Y - 1 \text{ in}$	$0.63 \cdot Xg$	$0.87 \cdot Xg$

Operator Placement and Gate Arm Geometry for 100° through 120° opening

Degree of Swing	X	Y	Xg	A	B
100	20.0 in (51 cm)	24.0 in (61 cm)	43.0 in (109 cm)	31.5 in (80 cm)	36.0 in (91 cm)
110	26.0 in (66 cm)	24.0 in (61 cm)	43.0 in (109 cm)	32.5 in (83 cm)	40.5 in (103 cm)
120	32.0 in (81 cm)	20.0 in (51 cm)	46.0 in (117 cm)	36.0 in (91 cm)	44.5 in (113 cm)

Maximum A = 38 in (97cm) and Maximum B = 47 in (121cm)

Prepare an Installation Site

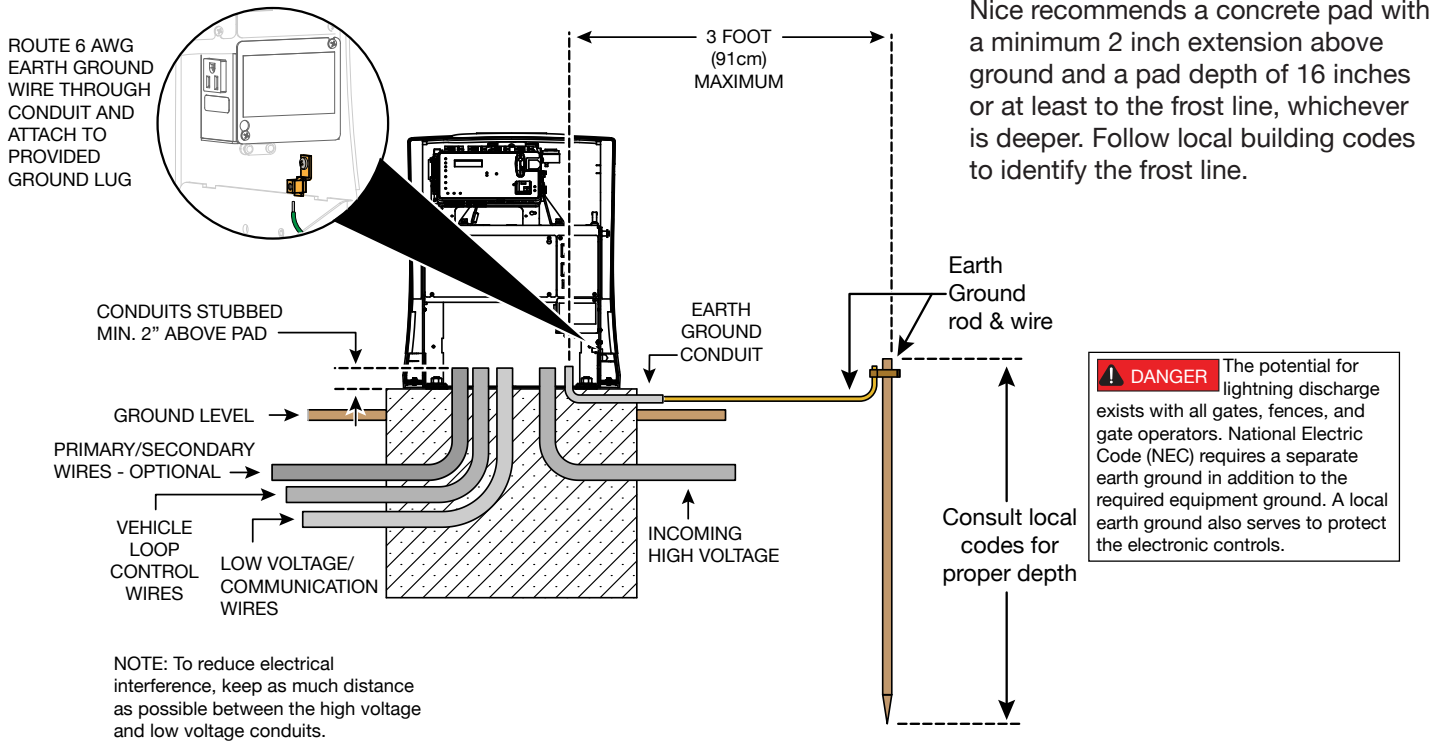

Figure 6. Conduits and Earth Ground

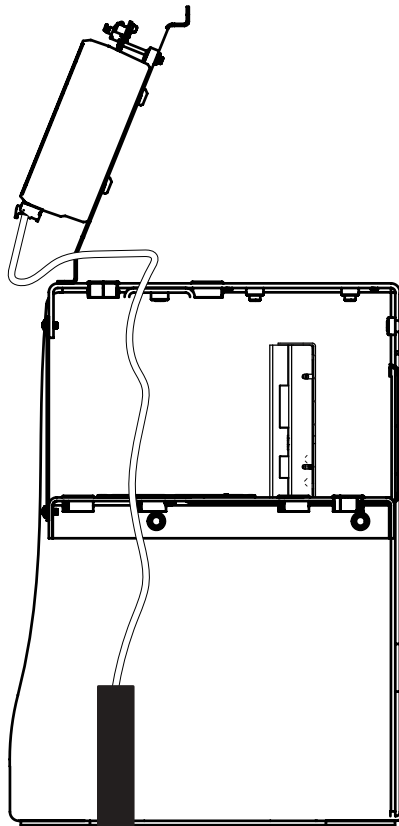

Figure 7. Preferred Control Wire Routing to SmartTouch 725

Install Arm Assembly

NOTICE

Top cap installation requires 6 in (15 cm) length of the small A arm exposed (Figure 31).

1. Set the DC power switch to OFF.
2. Loosen the taper clamp bolt with the taper wrench (Figure 9).
3. Attach the operator arm to the taper clamp (Figure 10).
4. Use Tables 1 through 4 to determine the length of the operator arm (A) and the gate arm (B) (Figure 11).
5. Loosen the set bolt on each arm and set the arms to length. Tighten the set bolts (Figure 12).
6. For safety reasons, secure the gate at the closed position to make sure that it does not move.
7. Position the gate bracket at Xg dimension.
8. Level the arm assembly.
9. Move the end of the assembly to Xg and mark the height so the arm assembly stays level (Figure 13).
10. Clamp the gate bracket at Xg and the marked height (H).
11. Connect the arm assembly to the gate bracket (Figure 14).
12. Make sure that the operator arm is below the gate arm (Section B above Section A, Figure 11).
13. For a bent arm in the closed position, install the set screw in the middle or inner position from the gate. A bent arm in the closed position allows the taper clamp to slip and reduces the risk of damage to the operator in the event of a gate strike (Figure 15 and Figure 16C).
14. For a straight (locked) arm in the closed position, install the set screw in the outer position from the gate. A straight arm in the closed position increases security, but increases the risk of damage to the operator in the event of a gate strike (Figure 15 and Figure 16D).

Note: Straighten the arm instead of overtightening the taper clamp for increased security.

15. Manually swing the gate between open and close. Check the arm assembly geometry and clearance with the operator.
16. Adjust the Xg position or the length of the arms with the set bolts to achieve correct gate geometry (Figure 16A).
17. Weld or bolt the gate bracket at the final position.
18. To set the arm lengths drill 17/64 inch holes through the holes on either side of the set bolts. Then put the 1/4 x 20 bolts through the holes and secure them with the lock nuts (Figure 17).

19. Alternatively, apply a 1/8 inch (3 mm) fillet weld to each seam to permanently set the length of the arm assembly (Figure 17).
20. Remove the set bolts (Figure 12).

Attach WARNING Signs

! WARNING Be sure to place the WARNING signs on the gate. For your records, take a photograph of the completed installation site.

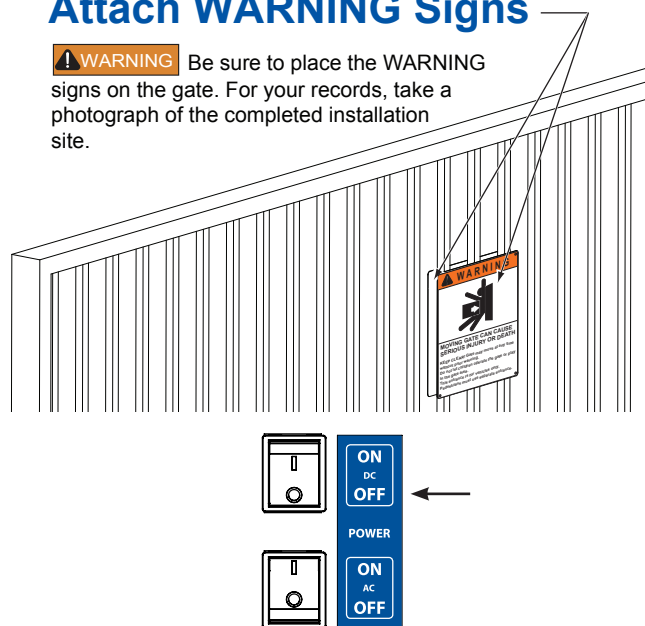

Figure 8. Set the DC Switch to OFF

Install Arm Assembly

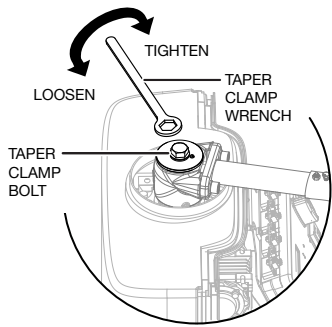

Figure 9. Taper Clamp Bolt and Taper Clamp Wrench

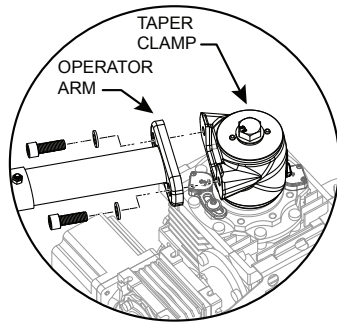

Figure 10. Operator Arm to Taper Clamp

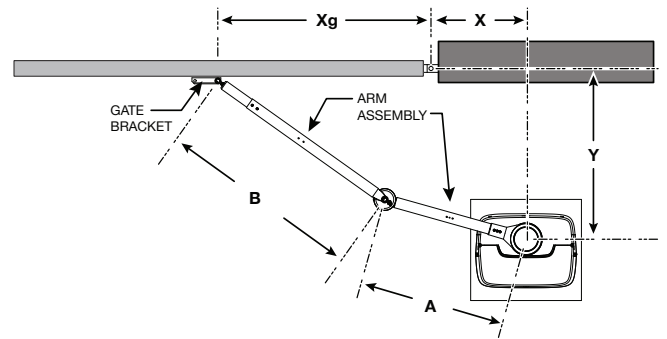

Figure 11. Installation Dimensions

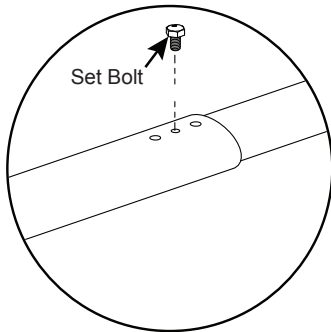
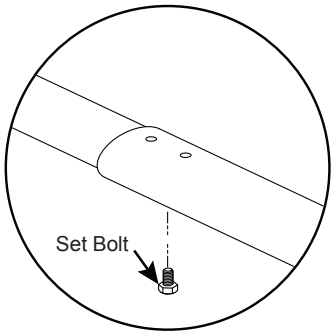

Figure 12. Set Temporary Arm Length

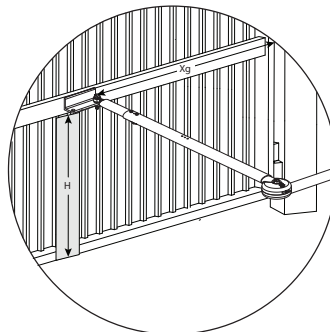

Figure 13. Gate Bracket Height

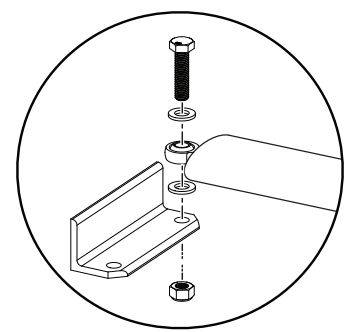

Figure 14. Gate Bracket Hardware

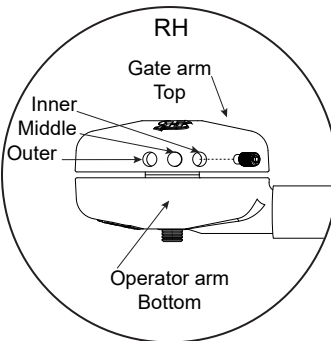
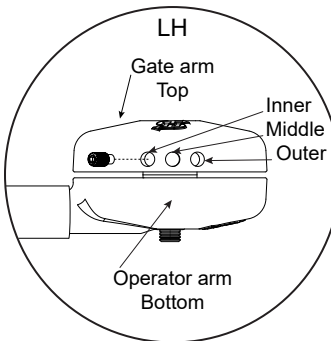

Figure 15. Set Screw Positions

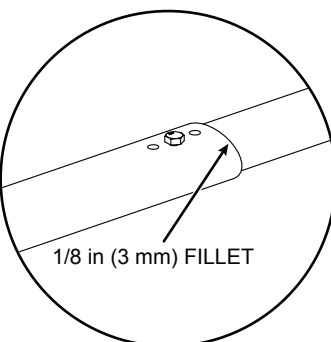
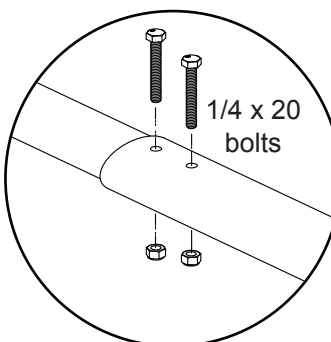

Figure 17. Set Permanent Arm Length

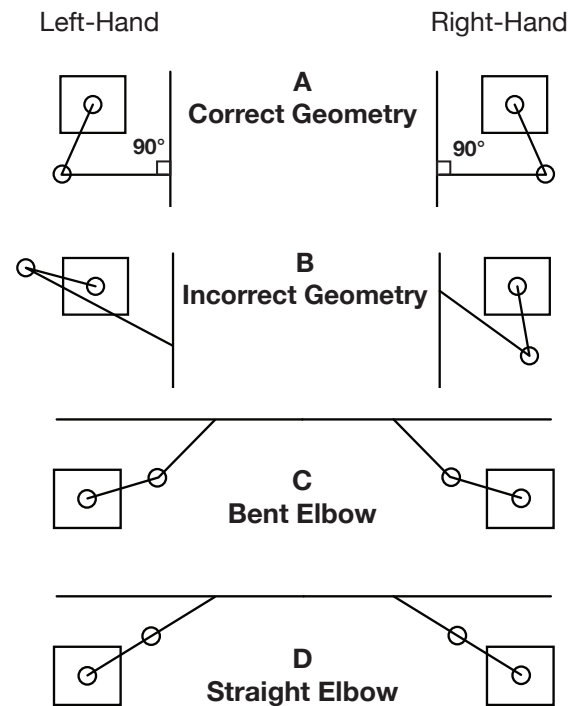

Figure 16. Gate Geometry

Adjust the Limit Sensors

The factory default positions of the limit sensor bracket screws are 1 and 5 for a LEFT-HAND installation (Figure 18).

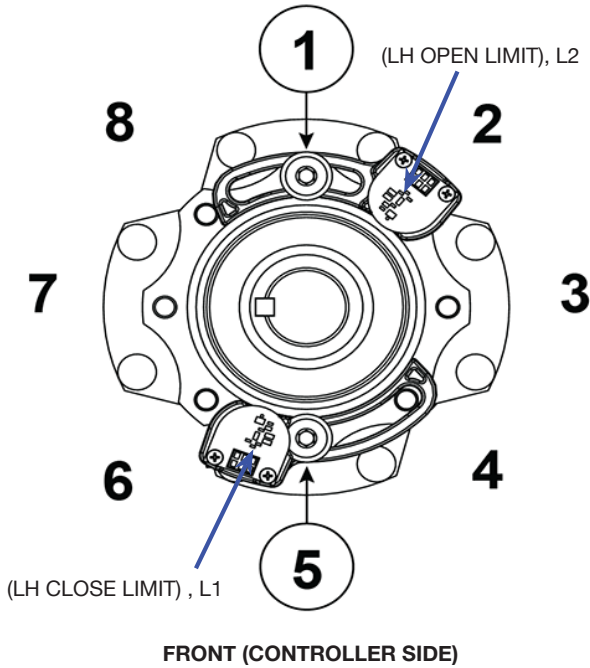

Figure 18. LEFT-HAND Installation

For a Right Hand position, use 5mm Allen wrench and move limit sensor brackets to positions 3 and 7. (Figure 18).

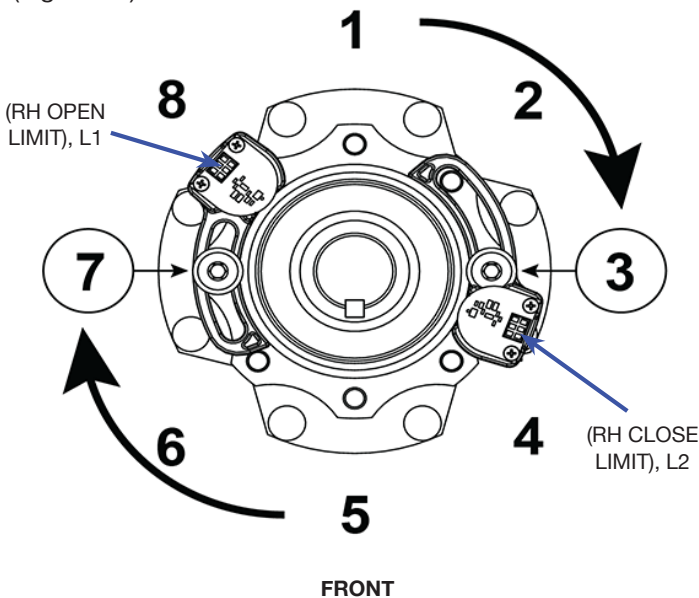
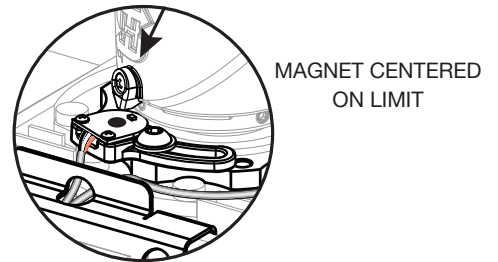

Figure 19. RIGHT-HAND Installation

Note: Some arm geometries will require moving the sensor bracket to the next gearbox hole.

ADJUST THE LIMIT SENSORS

1. Loosen the taper clamp bolt with the taper bolt wrench to allow the gate and arm assembly to rotate freely (Figure 20).
2. Loosen limit sensor bracket screws with a 5 mm allen wrench (Figure 21).
3. Move the gate to the CLOSED position.
4. Center the CLOSED limit sensor under the target magnet. Hold the limit sensor bracket in place and tighten the bolt.



5. Move the gate to the OPEN position.
6. Center the OPEN limit sensor under the target magnet and tighten the bolt.
7. Manually swing the gate between open and close positions. Verify the appropriate LED (Open or Close) is illuminated on the 725 Controller. Verify at full Open & Close positions there is 1-2" gap between gate and physical stops.

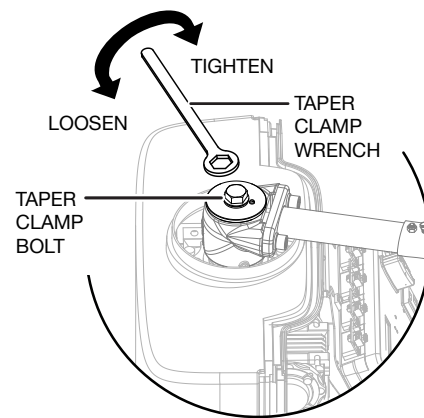

Figure 20. Loosen the Taper Clamp

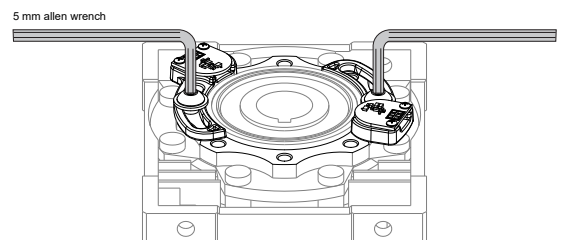

Figure 21. Loosen the Limit Sensor Bracket Bolts

Attach Back Cover

1. Remove the screws holding the operator arm to the taper clamp (Figure 22) and set the arm assembly to the side.

Note: If the incoming power is 208V/230VAC, refer to page 22 to set the voltage switch on the power supply before attaching the back cover.

2. Set the back cover over the taper clamp (Figure 23).

Note: Make sure that the raised tab on the controller mounting bracket is underneath the gasket groove in the back cover (Figure 24).

3. Install M6 hex bolts at the front cover latch posts (Figure 25). Snug, do not overtighten and crush plastic boss.

Note: Do not over tighten and crush the plastic stud.

4. Attach two M5 screws to both sides of the back cover (Figure 26).
5. Attach four M5 screws to the rear of the back cover (Figure 26).
6. Connect wires to stop button (Figure 27).
7. Reattach operator arm and continue to attach top cap instructions.

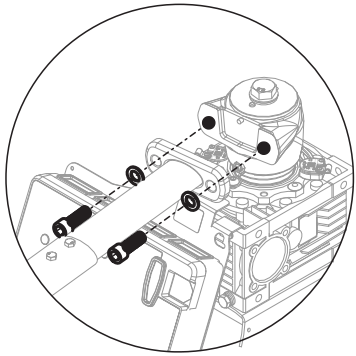

Figure 22. Remove the Operator Arm

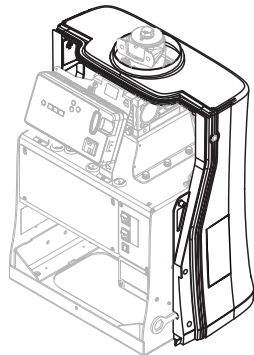

Figure 23. Place the Back Cover

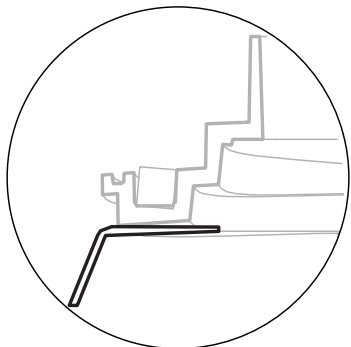

Figure 24. Align Mounting Bracket Tab and Gasket Groove

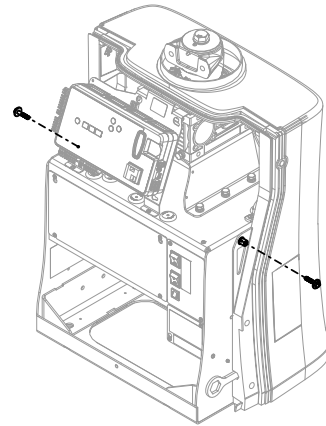

Figure 25. Install M6 Hex Bolts to Latch Posts

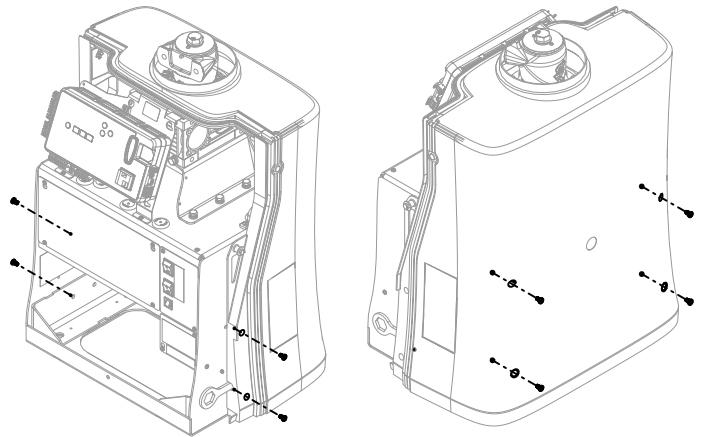

Figure 26. Install M5 Screws to Sides and Back

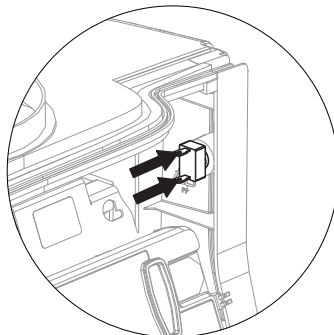

Figure 27. Connect Stop Button

Adjust Taper Clamp and Attach Top Cap

FUNCTION OF THE TAPER CLAMP:

The taper clamp will break free in a gate strike, but not slip during normal operation.

If the site requires free flow of traffic during installation, wait to tighten the taper clamp until you power and program the operator.

SET THE TAPER CLAMP:

1. Taper clamp wrench is supplied in the ship-with kit and is stored on the right side of the operator chassis. (Figure 28)
2. Release the taper clamp by rotating the bolt counterclockwise until it spins freely.
3. Manually swing the gate halfway between the open and close positions.
4. Set the taper clamp by rotating the bolt clockwise until it becomes difficult to turn.
5. To test taper clamp slip, push the end of the gate with 50-75 pounds of force to simulate a gate strike. (Figure 29).
6. If the taper clamp slips, turn the taper clamp bolt clockwise an additional 10-15 degrees..
7. Repeat steps 5 and 6 until the taper clamp does not slip below 50 pounds of force and slips easily above 75 pounds during the gate strike simulation.
8. Return the taper clamp wrench to its storage slot.

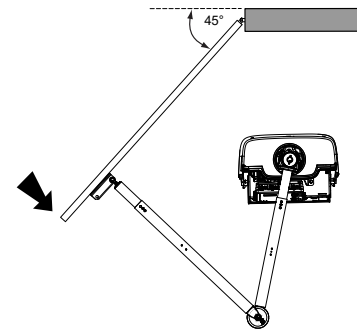

Figure 29. Test the Taper Clamp

TOP CAP SHIELD:

1. Thread zip ties through slots in shield. (Figure 30.).
2. Position the top cap shield underneath the operator arm. (Figure 31.)
3. Secure shield to underside of operator arm with zip ties.
4. Trim the ends of the zip ties. (Figure 32.)
5. Slide the top cap shield against the opening in the back cover and then pull it away less than 1/8 in. (Figure 32.)

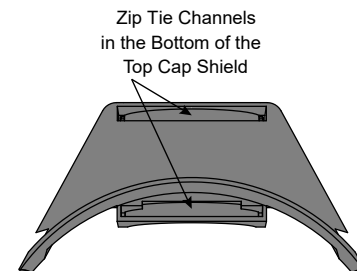

Figure 30. Zip Tie Channels

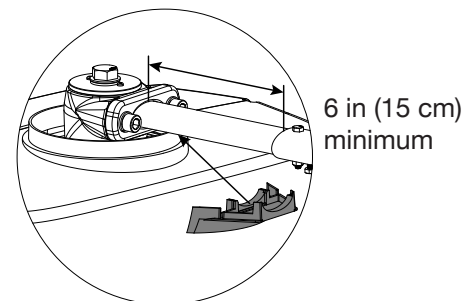

Figure 31. Position the Top Cap Shield

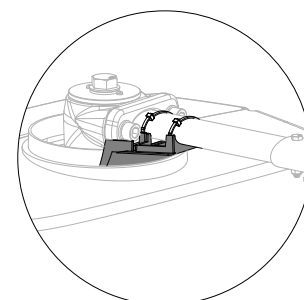

Figure 32. Wrap the Zip Ties Around the Arm

WARNING

Do not *over tighten* the taper clamp. An over tight taper clamp could cause damage to the operator during a gate strike or increase the risk of injury or death to pedestrians caught in an entrapment zone.

NOTICE

Do not under tighten the taper clamp, this could cause the taper clamp to slip during normal operation.

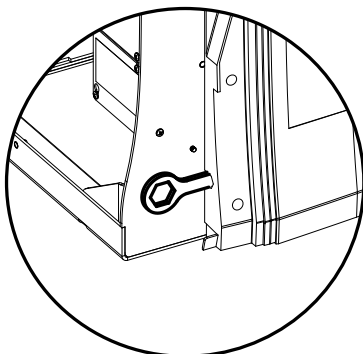

Figure 28. Store the Taper Wrench

Wiring and Power

WIRING 115VAC OR 208/230VAC POWER

- Verify AC power supply wires and low voltage accessory wires run through separate conduits. The input voltage to the AC power supply may cause interference and anomalies in SwingSmart 535 operation if the high voltage wires are routed through the same conduit as the low voltage wires.
- Maximum gate operator current draw is 7.5 Amps on a dedicated 115VAC circuit (20A dedicated circuit is recommended).
- Maximum gate operator current draw is 4 Amps on a dedicated 208/230VAC circuit (20A dedicated circuit is recommended).
- Make sure proper wire gauge is used for the length of the wire run. The following tables show the maximum allowable wire run from the power source to the operator for various wire sizes.

Wire Gauge versus Run			
AC Power	14 gauge wire	12 gauge wire	10 gauge wire
One operator 115V	485 ft (147 m)	775 ft (236 m)	1235 ft (376 m)
Two operators 115V	242 ft (73 m)	387 ft (117 m)	617 ft (188 m)

Wire Gauge versus Run			
AC Power	14 gauge wire	12 gauge wire	10 gauge wire
One operator 208/230V	1375 ft (419 m)	2185 ft (665 m)	3475 ft (1059 m)
Two operators 208/230V	687 ft (209 m)	1092 ft (332 m)	1737 ft (529 m)

NOTICE

Table 5 and Table 6 assume a dedicated circuit with an accessory power load up to 2A. Additional loads require that the wire size be increased or the distance of the run be decreased.

Operators are factory set for incoming power of 115VAC. If 208/230VAC, change the voltage switch on the power supply to 230VAC with a flathead screwdriver (Figure 33 and Figure 34).

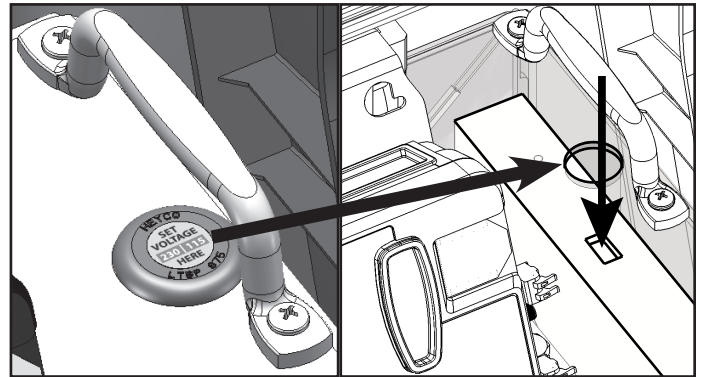

Figure 33. Voltage Switch Access



(Factory Setting)



(Requires Installer Action).

Figure 34. Voltage Switch Positions

Always connect electrical power and ground the operator in accordance with the NFPA 780 & NEC, Article 430 and Article 250. Research and adhere to other local codes that may apply.

WARNING

Applying 208/230VAC power will damage a factory set 115V power supply.

Wiring and Power

DANGER

Turn off AC power at the source (circuit breaker panel) before accessing the wires in the operator junction box. Follow facility Lock Out/Tag Out procedures.

1. Make sure both the DC and AC power switches are in the OFF position.
2. Connect the battery harness to the back bottom left hand corner of the drive module. (Figure 35)
3. Remove the junction box cover. (Figure 36)
4. Connect the incoming power supply wires to the AC or DC (solar) terminal block inside the junction box. Match the wire colors (Figure 37.)

Note: Remember to set the power supply voltage switch to match 115VAC or 208/230VAC (Figure 33-34)

5. Organize all the wire connections and put the cover onto the junction box.
6. For solar installations, remove the power switch mounting plate and disconnect the red (+V) and blue (-V) wires from the power supply. Tape or wire nut the ends separately to prevent shorts (Figure 38).

Note: 535 operators require 24VDC rated solar panels with a maximum open circuit voltage of 48VDC.

7. For 208V/230V or solar (24V) installations, place the label (included in the ship with kit) over the factory default 115V 1Ø label.
8. Set both AC and DC power switches to ON (Figure 39).
9. Firmware version will appear on LCD display and then the Setup Menu.

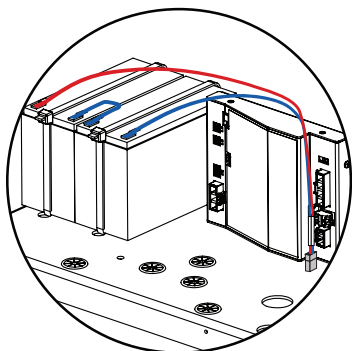

Figure 35. Battery Harness to Drive Module



Figure 36. Junction Box Cover

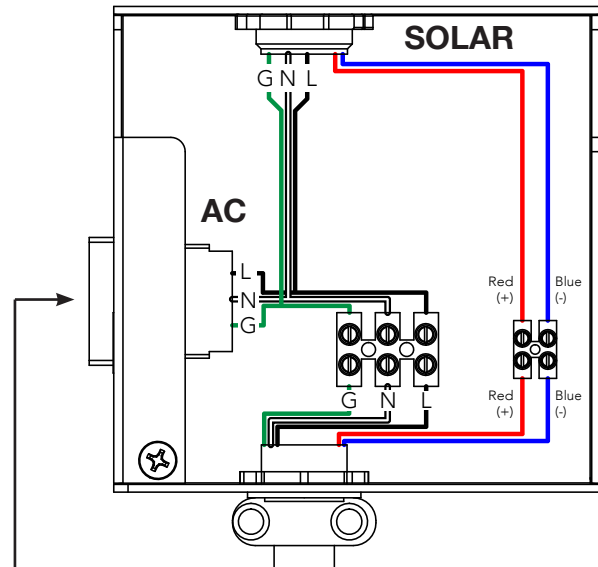

Figure 37. 115VAC/230VAC and Solar DC Terminals

Connect service outlet lead wires to 115VAC only.

WARNING

WARNING: Do not connect AC power to the Red and Blue Solar Panel wires.

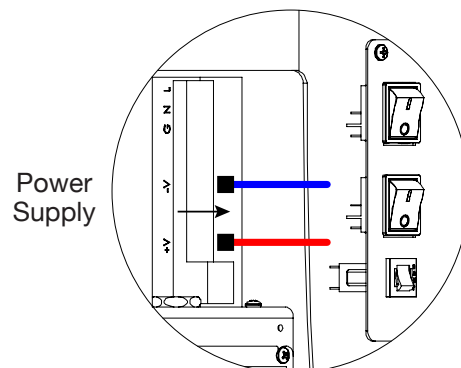

Figure 38. Disconnect DC Power Supply Wires

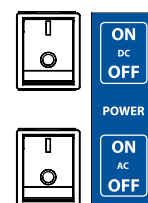

Figure 39. Set Both Power Switches to ON

Controller Connections

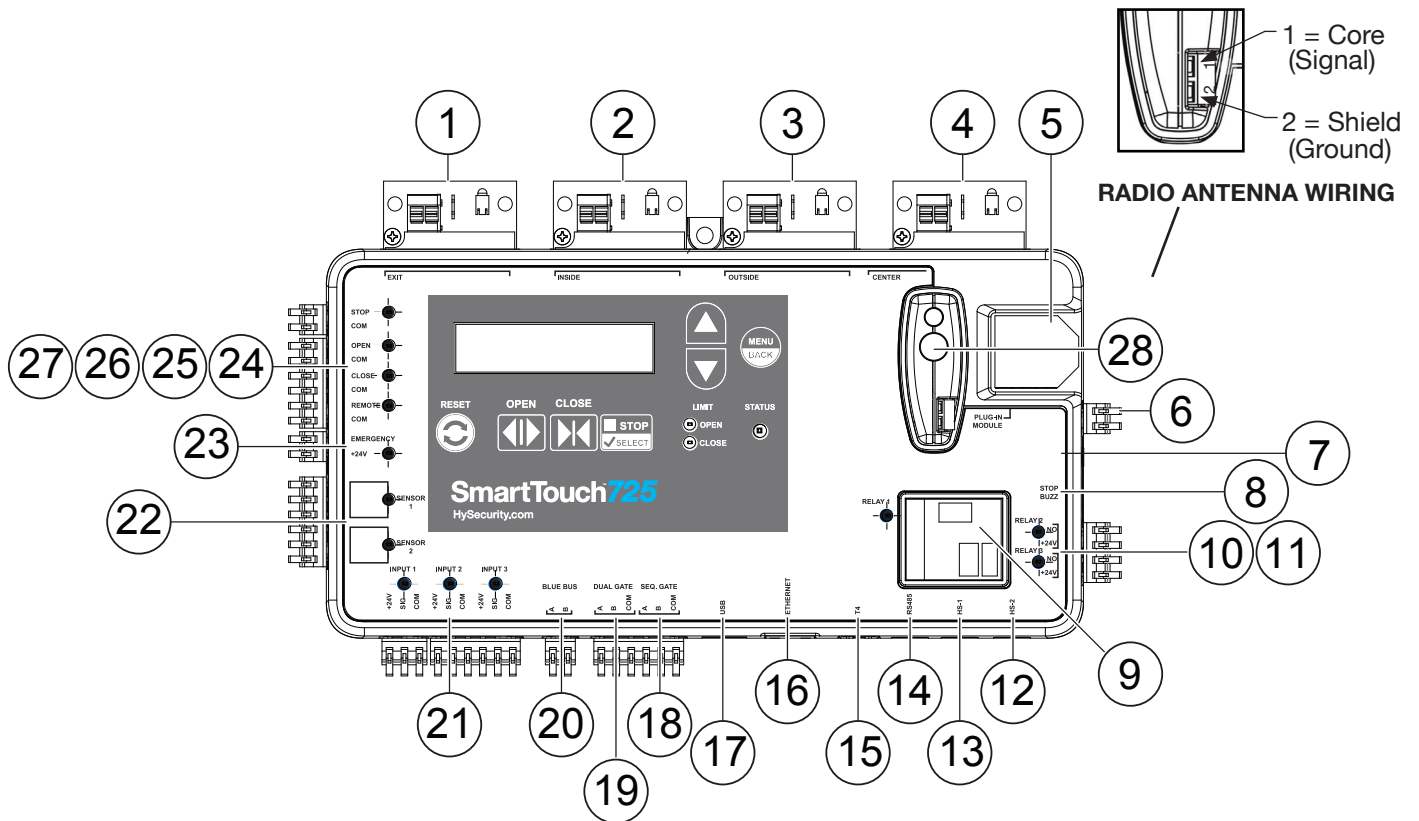

Figure 40. SmartTouch 725 Controller Connections

1. **Hy5B EXIT Loop** – This opens a fully closed gate or reopens a closing gate.
2. **Hy5B INSIDE Loop** – Reversing loop on secure side.
3. **Hy5B OUTSIDE Loop** – Reversing loop on public side.
4. **Hy5B CENTER Loop** – Detect vehicle in swing arc of the gate
5. **(Not Used)**
6. **(Not Used)**
7. **Chassis Ground**
8. **Stop/Buzzer Harness**
9. **Relay 1** – Mechanical relay
10. **Relay 2** – Solid state relay
11. **Relay 3** – Solid state relay
12. **HS-2** – Can connect to expansion module.
13. **HS-1** – Harness connects communication to drive module.
14. **RS485**
15. **T4 Port**
16. **Ethernet**
17. **USB** – Used for firmware updates & fault log download.
18. **Sequenced Gate Connection**
19. **Dual Gate Connection**
20. **BlueBUS** – For use with NICE BlueBUS devices
21. **Programmable Inputs 1-3**
22. **Programmable Sensor Inputs 1-2** – UL325 required external entrapment sensors
23. **Emergency** – Programmable to fire department open or emergency close
24. **Remote** – Programmable for three functions, defaults to step function
25. **Close** – Close only input
26. **Open** – Open only input
27. **Stop** – Stop
28. **OXI MegaCode** – Radio for NICE access control devices.

User Interface

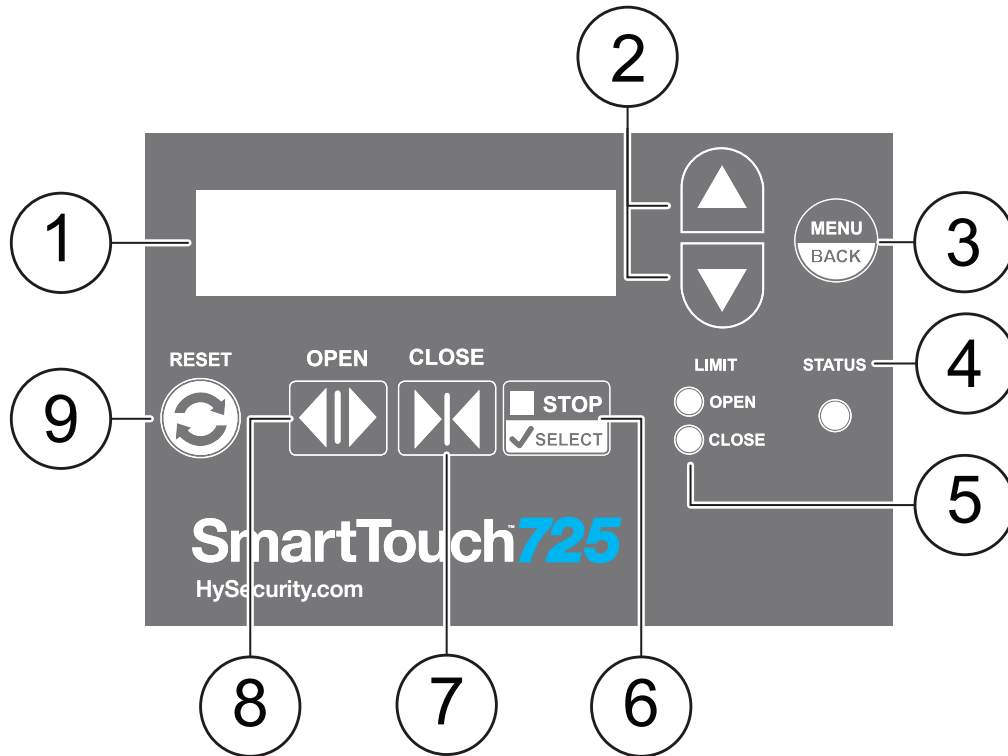

Figure 41. SmartTouch 725 Controller User Interface

1. **OLED Display** – 16 characters per line, 2 line display. Displays current operator status, menus, and alerts/faults/errors. In h6.03 and later firmware, the display will shut off when none of the on board buttons have been pressed for a while. Pressing any button will turn it back on. This is to save power and extend the life of the display.
 2. **Up/Down Arrows** – Navigate through menu and display options while in Menu Mode.
 3. **Menu/Back** – Open the configuration menu from the operator status display. Go back from the current menu (exit the current menu).
 4. **Status LED** – Indicates gate operator status
 - a. Flashing Red – An Alert, Fault, or Error has occurred. Immediately shut down the machine and correct the fault.
 - b. Solid Red – Operator is in Menu Mode
 - c. Flashing Green – Operator is in Run Mode
 - d. Flashing Blue – Operator is pairing with a Bluetooth device.
 - e. Alternating Blue and Red/Green – Operator is communicating with a Bluetooth device.
 5. **Limit Open/Close** – Solid green when target magnet activates limit sensor.
 6. **Stop/Select** – Stops gate travel when in run mode. Press to select current menu option or to confirm setting value.
 7. **Close** – Closes the gate while in Run Mode.
 8. **Open** – Opens the gate while in Run Mode.
 9. **Reset** – Press to clear faults and return to Run Mode. Cannot be used in Menu Mode.
- Note: You can configure the menus on battery power when an external power source is not yet present.

Initial Setup

CONFIGURE THE SETUP MENU (SWING)

The first time the SmartTouch 725 controller power on, you must set USAGE CLASS, GATE HANDING, and LEARN LIMITS before normal operator.

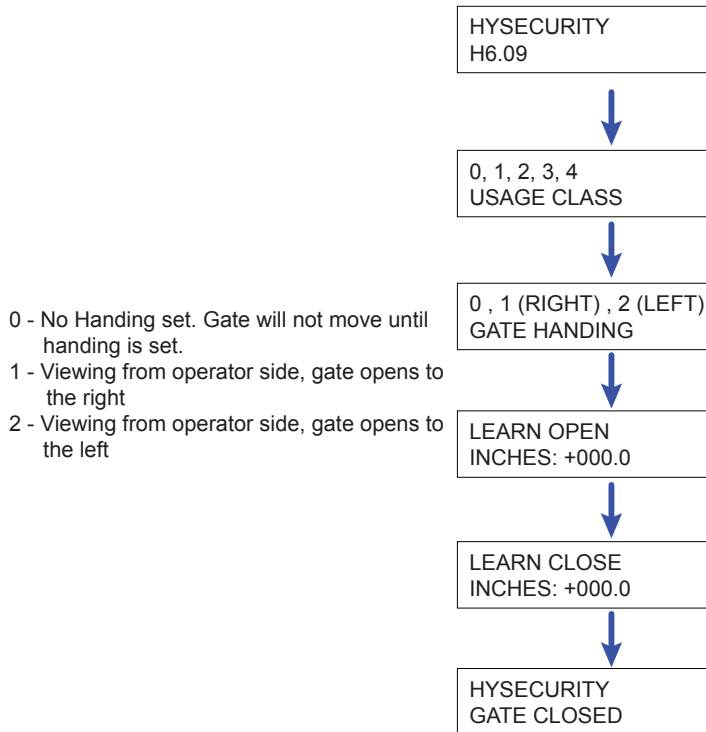

1. Set the DC and AC switches to ON. Firmware version appears on the display and then USAGE CLASS - 0
2. Press SELECT, press the UP or DOWN arrow to navigate to the correct USAGE CLASS (page 5), and press SELECT to accept value.
3. Press the UP or DOWN arrow until GATE HANDING appears on the display, press SELECT, press the UP or DOWN arrow to navigate to the correct option, and press SELECT to accept value.
4. The SmartTouch 725 controller resets, display shows "1 (STARTING) - SCAN BLUEBUS" then shows "SCANNING FOR BLUBUS".
5. After BlueBus Scan, operator display shows "LEARN OPEN - DEGS 000.0".
6. Press the OPEN button and the gate will slowly move to, and stop on, the open limit.
7. Press the stop/select button twice to store the open limit position. Display will show Learn Close.
8. Press the CLOSE button and the gate will slowly move to, and stop on, the close limit.
9. Press the SELECT button twice to store the close limit position. Operator will reset and display Gate Closed.

NAVIGATE THE MENUS

Press MENU/BACK to enter the menus or to exit the current screen (up one level without saving any changes).

Press the UP or DOWN arrow to change the current selection until you find the one you want.

Press SELECT to access the menu or sub-menu. Press SELECT to accept the current option or value.

Note: These navigation instructions are the same throughout the SmartTouch 725 controller menus.

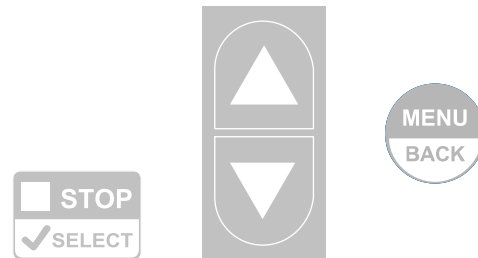

Figure 42. Configuring Setup Menu

Operator Configurations

- **USAGE CLASS:** UL 325 designations 1-4 (refer to Safety Requirements page 5)
- **CLOSE TIMER:** Number of seconds before open gate initiates closure after all inputs are clear.
- **GATE HANDING:** Direction gate opens when viewed from the operator.
- **AC LOSS:** Action operator performs during an AC power loss. (Refer to Advanced Manual)
- **BATTERY TYPE:** Configure if using larger capacity batteries. (Refer to Advanced Manual)
- **OPEN TIME ALERT:** Activates relay (function 8) when gate is open longer than selected time period.
- **LOITERING ALERT:** Activates relay (function 13) when vehicle is over Outside Obstruction Loop with gate closed longer than selected time period.
- **LEARN LIMIT:** Set to 1 to place operator in learn limits mode. Installer must then reset open and close positions.
- **FACTORY DEFAULTS:** Set to 1 to erase all installer entered settings and return to factory defaults.
- **OPERATOR TYPE:** Factory set. Used only if replacing the SmartTouch 725 Controller.
- **MENU PIN:** Allows installer to set a 4-digit security pin to restrict access to SmartTouch 725 controller menus.

OPERATOR CONFIGURATIONS	
USAGE CLASS (0†)	0 (GATE DISABLED) 1 (RESIDENTIAL) 2 (PUBLIC) 3 (INDUSTRIAL) 4 (HIGH-SECURITY)
CLOSE TIMER	0 (OFF)† 1 - 99 (SECONDS)
GATE HANDING	0 (NOT ASSIGNED)† 1 (RIGHT) 2 (LEFT)
AC LOSS	0 (UPS FAIL OPEN) 1 (UPS FAIL CLOSE)† 2 (AUTO OPEN) 3 (NO CLOSE TIMER)
BATTERY TYPE	0 (STANDARD)† 1 (EXTENDED) 2 (MAXIMUM)
OPEN TIME ALERT	0 (0 SECS) 1 (15 SECS) 2 (45 SECS)† 3 (75 SECS) 4 (105 SECS) 5 (135 SECS)
LOITERING ALERT	0 (0 SECS) 1 (15 SECS) 2 (45 SECS) 3 (75 SECS)† 4 (105 SECS) 5 (135 SECS)
LEARN LIMIT	0 (OFF) 1 (ON) †
FACTORY DEFAULTS	0 (CUSTOM) † 1 (RESET TO)
OPERATOR TYPE (12†)	1-17 (OPERATOR TYPE)
MENU PIN (0†)	0 0 0 0

Note: Refer to Appendix in Web version Advanced manual for more details on Operator Configurations

† = Indicates default

BI-Parting Gate Setup

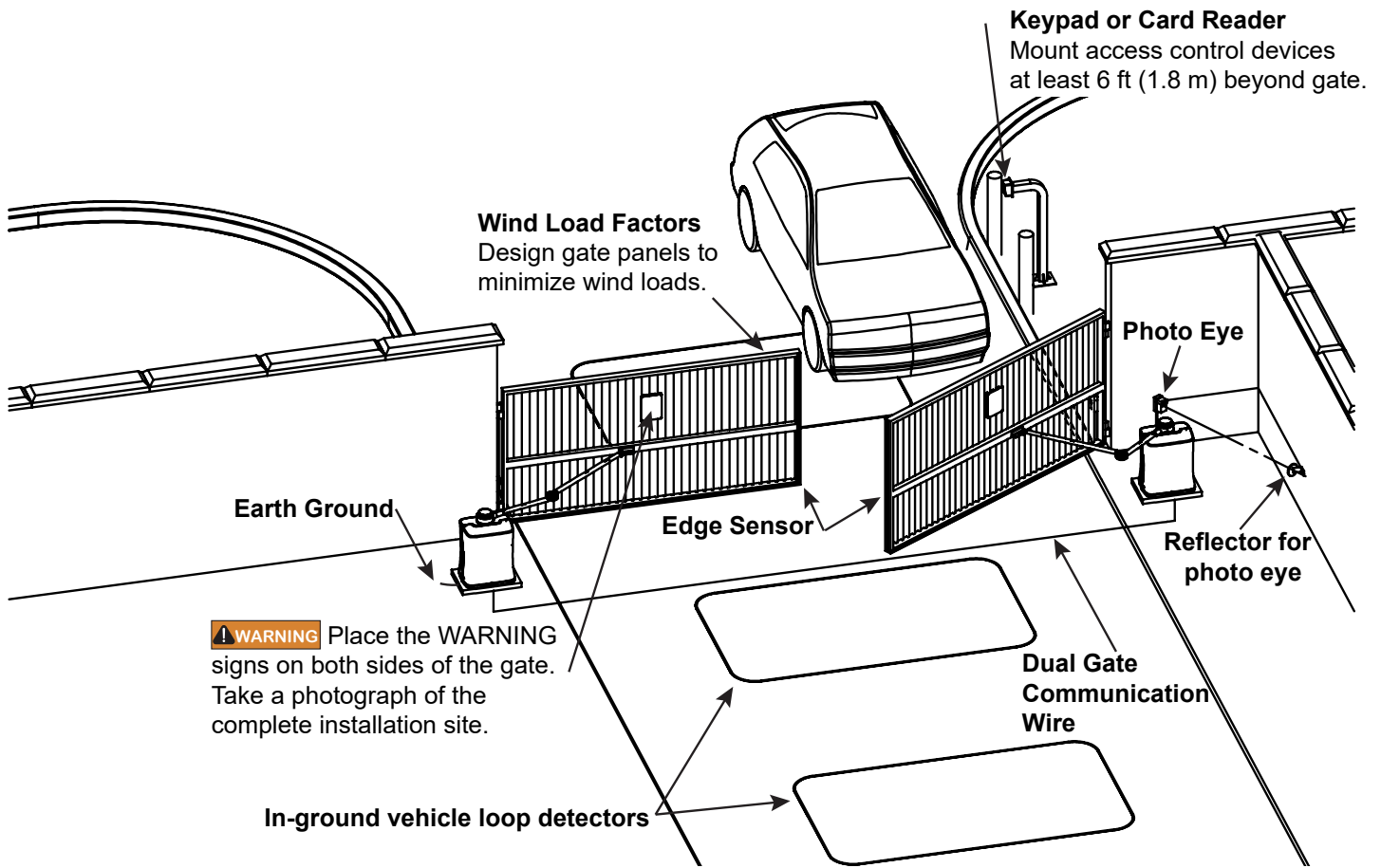

1. Install the primary and secondary operators.
2. Set up external entrapment sensors, vehicle detectors, and other input devices on both operators before you connect the operators.
3. Test cycle the operators independently to make sure there are no problems with gate travel and open/close stops.
4. Install a communication wire between the two operators. Match A-A, B-B, and COM-COM. Install the grounding wire on only one of the controller mounting brackets.

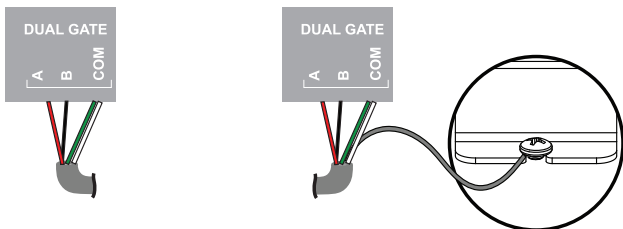
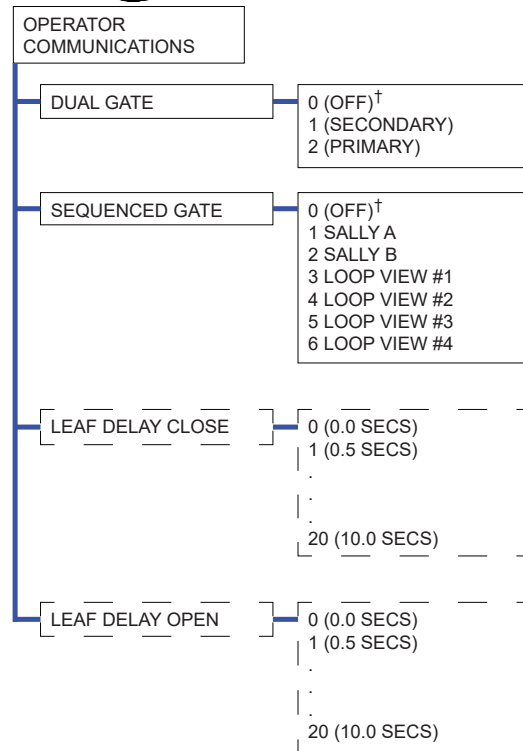

Figure 43. Dual Gate Connection

5. Set one operator as the primary and the other as the secondary.
6. Test the gate operation.
7. Adjust LEAF DELAY CLOSE and LEAF DELAY OPEN if required.



LEAF DELAY OPEN/CLOSE ONLY APPEAR IF THE GATE OPERATOR IS SET UP AS PRIMARY OR SECONDARY.

For Sequenced Gate applications refer to Advanced Manual.

[†] = Indicates default

Controller Inputs

SmartTouch 725 Controller Input Examples Only

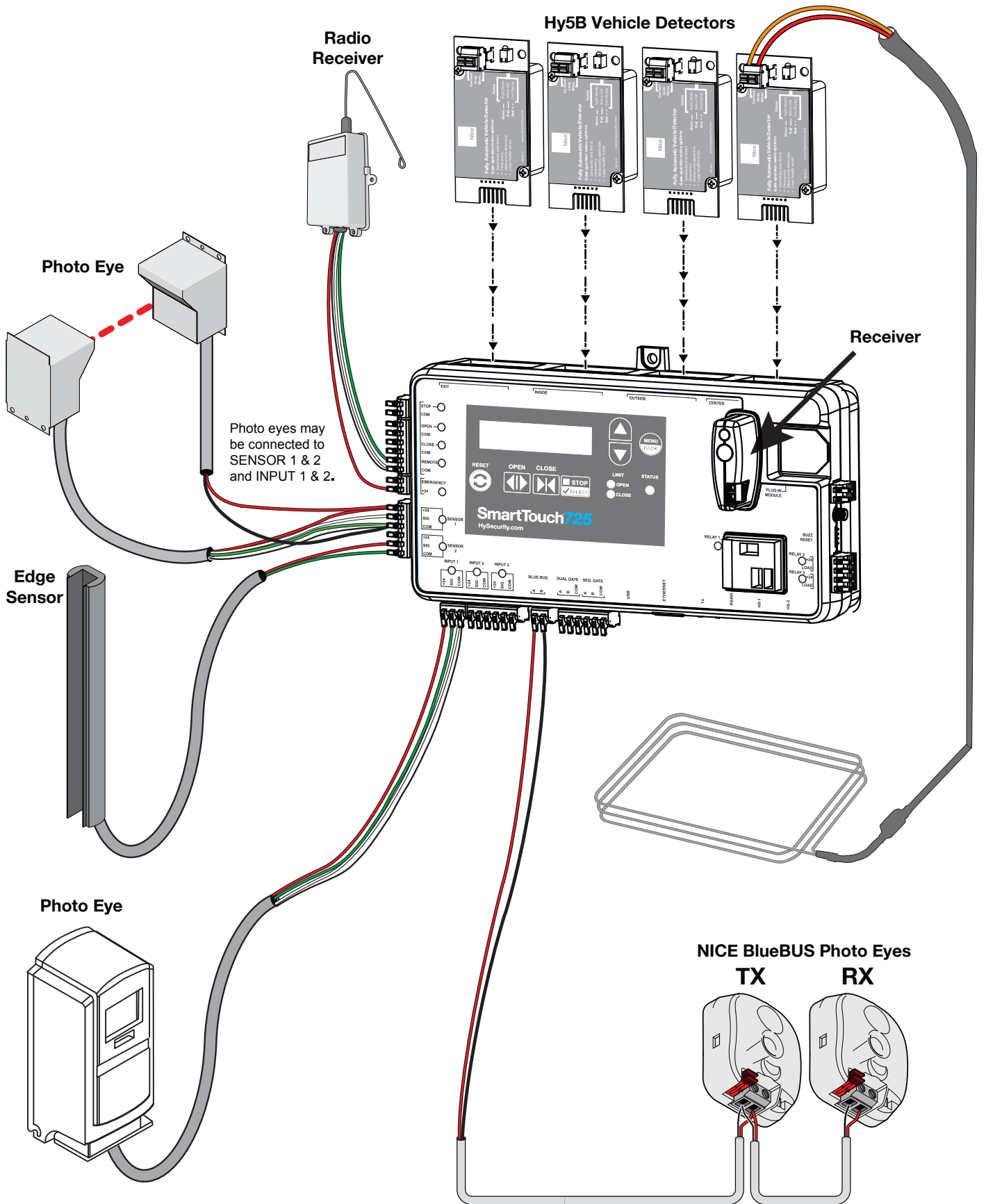

Entrapment Sensor Wiring - Bluebus

Nice provides one BlueBUS thru beam photo eye pair typically used as EYE CLOSE

1. Verify the jumpers on transmitter (TX) and receiver (RX) are in the same positions (Figure 44).
2. Install the BlueBUS photo eyes in appropriate locations for entrapment protection (page 9).
3. Set the AC and DC switches to OFF.
4. Route the wires to the inside of the operator chassis (Figure 7).
5. Install the wires between the TX and RX and then into BlueBUS terminals on the SmartTouch 725 controller (Figure 45)

Note: With BlueBUS technology there are 4 total close direction pairs and 2 open direction pairs available. Refer to Advanced Manual for more information. Pairs may either be connected in parallel to one another or directly to the SmartTouch 725 Controller.

6. Set AC and DC switches to ON.
7. In EXTERNAL COMMUNICATIONS MENU, select

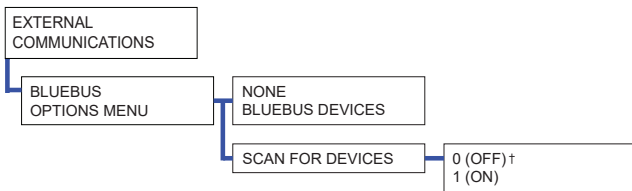

BLUEBUS OPTIONS MENU, and set SCAN FOR DEVICES to 1 (ON).

8. Display will show EYE CLOSE BlueBUS P1 or whatever matches the jumper configuration.
9. In ENTRAPMENT SENSOR RESPONSE menu, set the desired response action for each entrapment type.
10. Test the function of each sensor pair.

RX LED Status Light	Status
Off	No power
3 flashes, pause, repeat	Controller has not memorized the pair
Slow flashes	Good signal

Direction	Pair	Jumper Positions (Pairs must match)	BlueBUS Photo Eye Position
CLOSE	P1		FOTO
OPEN	P5		FOTO 2

Figure 44. BlueBUS and Jumper Designation

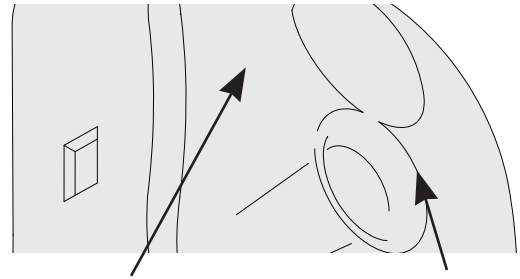

Example jumper position
CLOSE P1

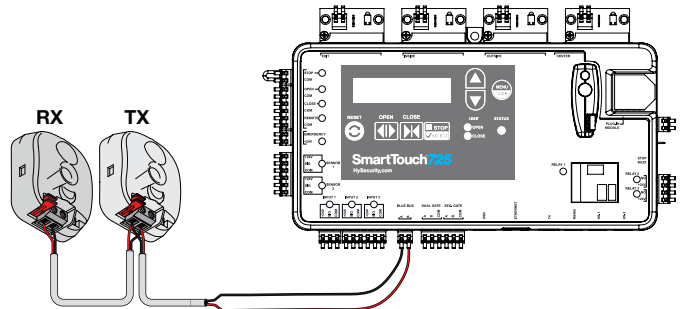

NOTE: Matching wire polarity is not required for BlueBUS photocells.

NOTE: Jumper locations shown here are for a CLOSE P1 installation.

Figure 45. Connect the BlueBUS Photo Eye

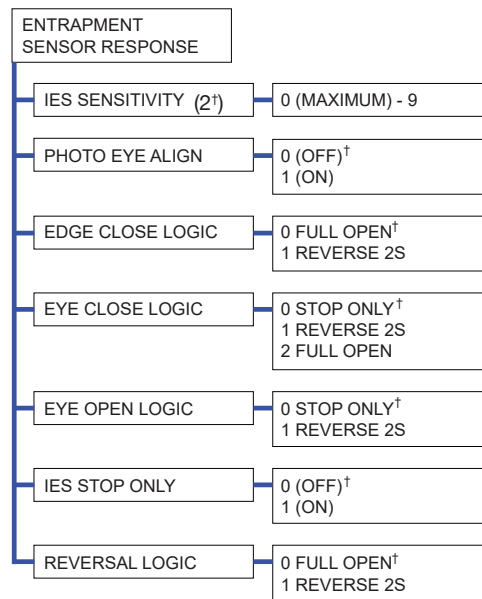

Note: When Photo Eye Align mode is turned on, the display will show all the sensor inputs that are programmed for photo eyes and will show if they are active or not (a 1 indicates the eye is present and aligned and a 0 indicates the eye is not aligned or blocked). Any BlueBus eye will also show up on the display.

† = Indicates default

Additional External Entrapment Sensors

Additional non-BlueBUS non-contact sensors and contact sensors can connect to the SmartTouch 725 Controller.

1. Install the non-BlueBUS entrapment sensor in an appropriate location for entrapment protection (page 9).
2. Set AC and DC switches OFF
3. Route the wires to the inside of the operator chassis (Figure 7).

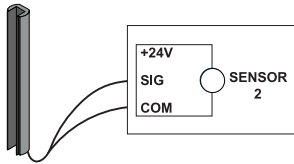
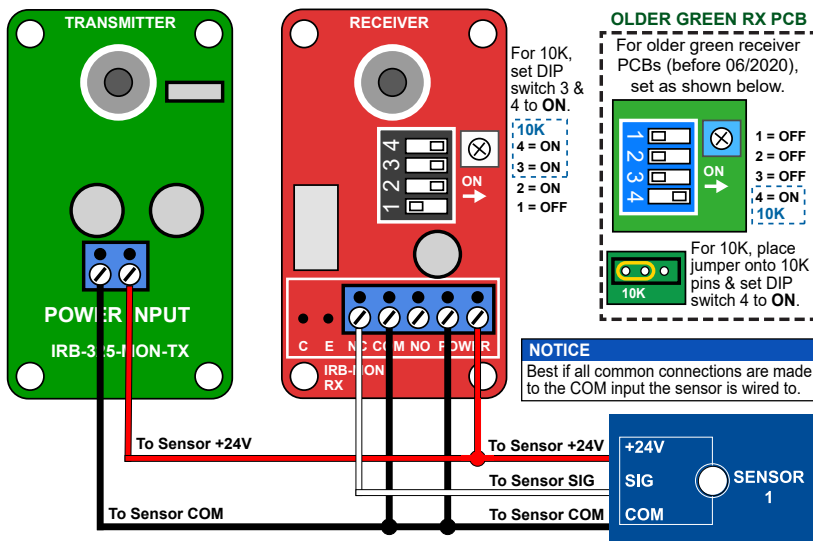

Figure 46. Sensor Connection

4. Install the wires into Sensor #1 or Sensor #2 on the SmartTouch 725 controller (Figure 46).
5. Set AC and DC switches to ON.
6. In PROGRAMMABLE INPUTS menu, select the SENSOR TYPE for each external entrapment sensor. The indicator LED changes to green when sensor is activated or not installed correctly.
7. In ENTRAPMENT SENSOR RESPONSE menu, set the desired response action for each entrapment type.
8. Test the function of each sensor.

PROGRAMMABLE INPUTS	
EMERGENCY INPUT	0 EMERG CLOSE 1 FIRE DEPT OPEN †
SENSOR #1 TYPE	1 NOT USED † 2 EYE CLOSE 3 EDGE CLOSE 4 EYE OPEN 5 EDGE OPEN 6 EDGE BOTH (SWING ONLY)
SENSOR #2 TYPE (1†)	“SEE SENSOR #1 TYPE”
INPUT #1 TYPE	1 NOT USED 2 EYE CLOSE 3 EDGE CLOSE 4 EYE OPEN 5 EDGE OPEN 6 EDGE BOTH (SWING ONLY) 7 NOT USED 8 PARTIAL OPEN (SLIDE ONLY) 9 OPEN INTERLOCK 10 TIME CLK OPEN 11 NOT USED 12 BLK FREE EXIT 13 EXIT LOOP † 14 INSIDE LOOP 15 OUTSIDE LOOP 16 CENTER LOOP 25 OPEN INPUT 26 CLOSE INPUT 27 REMOTE INPUT 43 WINDSPEED
INPUT #2 TYPE (15†)	“SEE INPUT #1 TYPE”
INPUT #3 TYPE (16†)	“SEE INPUT #1 TYPE”



EXAMPLE: EMX IRB-MON Photo Eye Wiring (10K monitoring)

List of Entrapment Sensors

COMPATIBLE EXTERNAL SENSORS

NOTICE

The SmartTouch 725 Controller inputs use 10k or 4-wire pulsed monitoring. Connect sensor using sensor instructions for the compatible output connections. The SmartTouch 725 Controller does not support normally closed inputs.

Table 7. Sensors Tested for Use with Nice and HySecurity Operators

	Mfg. Part #	Mfg.	Details	10k or 4-Wire Pulsed	Part #
Photo Eyes (Retroreflective)	E3K-R10K4-NR-1	Omron	40 ft max range limit	10k	MX000999
	NIR-50-325	EMX	45 ft max range limit	10k	
	IRB-RET	EMX	53 ft max range limit	Both	
	E-931-S50RRGQ	Seco-Larm	46 ft max range limit	10k	
Photo Eyes (Through-Beam)	IRB-MON	EMX	65 ft max range limit	10k	MX3990
	E-960-D90GQ	Seco-Larm	90 ft max range limit	10k	
	BlueBUS	Nice	65 ft max range limit		
Edge Sensors	Sentir Series	ASO Safety	Channel mount, high profile Channel mount, low profile Round, wraparound Square, wraparound	10k	AS1502-0440-05 AS1502-0430-05 AS1501-0760 AS1501-0790
	CPT210-2U-#-T2	Miller Edge	10k resistor termination (replace # with length requirement in feet)	10k	
Edge, Wireless Kits	iGAZE RE Kit	Transmitter Solutions	50 ft line of sight max range limit	10k	
	WEL-200 (kit with receiver and transmitter)	EMX	200 ft line of sight max range limit	Both	

Set IES Sensitivity

To comply with UL 325 Safety Standards, HySecurity operators are equipped with a Type A, Inherent Entrapment Sensor (IES). The IES firmware monitors the average motor current when a gate is in motion and reverses direction of gate travel when the current exceeds a self-adapting threshold.

A spike in motor current can be caused by the gate hitting a pedestrian, a collision with a vehicle, failing gate hardware, extreme wind gust, or any other force applied against the moving gate.

To set the IES sensitivity for your site follow these instructions:

1. Press MENU on the SmartTouch 725 Controller.
2. Press the UP or DOWN arrow to navigate to ENTRAPMENT SENSOR RESPONSE, press SELECT.
3. Press the UP or DOWN arrow to navigate to IES SENSITIVITY, press SELECT.
4. Press the UP or DOWN arrow to choose an IES SENSITIVITY, press SELECT to update the setting.

WARNING

In order to minimize risk of injury, use the lowest IES Sensitivity setting that results in reliable operation.

Note: Settings 0-8 are adaptive and setting 9 is fixed.

5. Press BACK until the display shows the operator status. (Open, Close, or Stop)
6. Run the operator for 3 uninterrupted gate cycles so the IES can adapt to the new setting.
7. To test IES sensitivity, apply force to the moving gate with an immovable obstruction to trigger the IES. Gate will stop motion and reverse for two seconds. "SAFE MODE" appears on the display.

WARNING

Do not risk injury by using any part of your body to test IES Sensitivity

8. If the IES sensitivity requires adjustment based on performance or safety concerns, repeat steps 1 - 7

Note: In Safe Mode, the automatic close timer is disabled, but any open or close input restarts gate motion. Safe Mode clears when full travel reached or Reset button pushed.

Note: A second IES trip before Safe Mode is cleared, results in an Entrapment Mode Alert which can be cleared with a Reset on the controller, an open input, stop input, or stop button on operator cover.

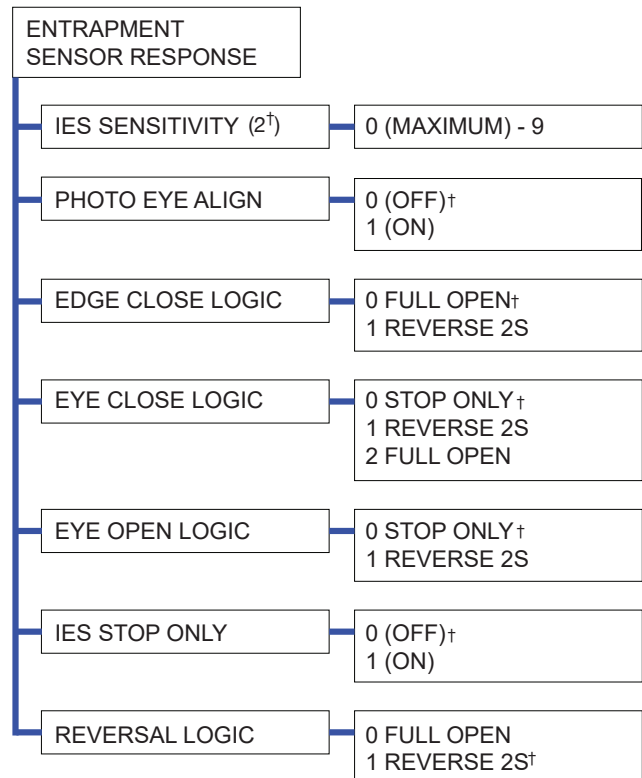

SmartTouch 725 - HY5B Module

INSTALL AN HY5B AND VEHICLE LOOP DETECTOR

There are 4 Hy5B ports on the SmartTouch 725 controller: Free Exit, Outside Obstruction, Inside Obstruction, and Center. Refer to Appendix A for a standard loop layout illustration.

1. Route the loop detector wires through the operator chassis to the SmartTouch 725 Controller.
2. Switch off AC and DC power.
3. Connect the wires to the Hy5B module.
4. Plug the Hy5B into the appropriate port (remove rubber plug).
5. Use zip ties and the holes in the aluminum controller bracket to neatly organize the loop lead wires to keep wires out of the way and prevent them from moving.
6. Switch on AC and DC power. The display will show loop detectors 'Initializing'.
7. In LOOP OPTIONS menu configure the appropriate loop detector settings.

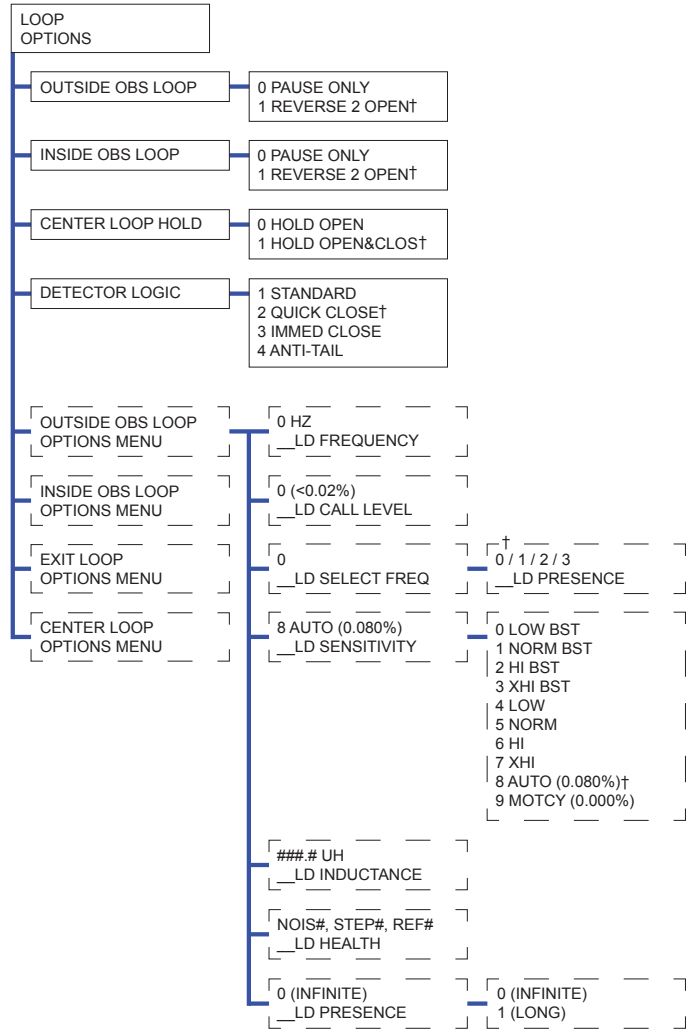
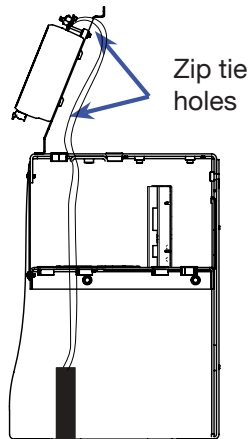
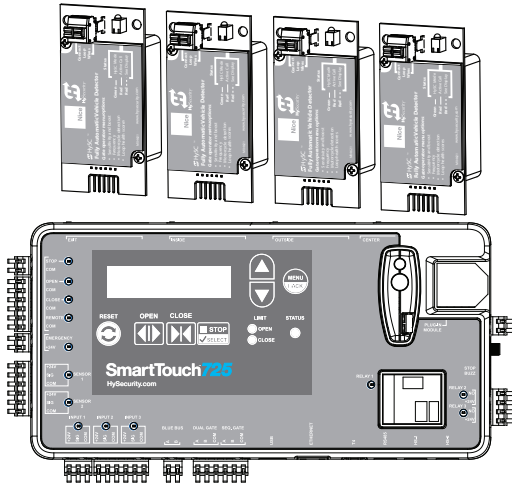

MENU STRUCTURES FOR LOOP OPTIONS ARE VISIBLE AND CONFIGURABLE ONLY WHEN AN HY5B MODULE IS INSTALLED INTO THE SmartTouch 725 CONTROLLER. OOLD, IOLD, ELD, AND CLD SUB-MENUS ARE IDENTICAL.

† = Indicates default

Relay Outputs - Basic

The three relays on the SmartTouch 725 controller are configurable to perform a wide range of options for integration with external devices. **For more information, see Advanced Manual**

1. Install the relay controlled device according to the manufacturer's instructions.
2. Route the relay wires to the SmartTouch 725 Controller (Figure 47).
3. Install the relay wires in the appropriate relay terminals: mechanical (Relay 1) or solid state (Relay 2 and 3) (Figure 48).

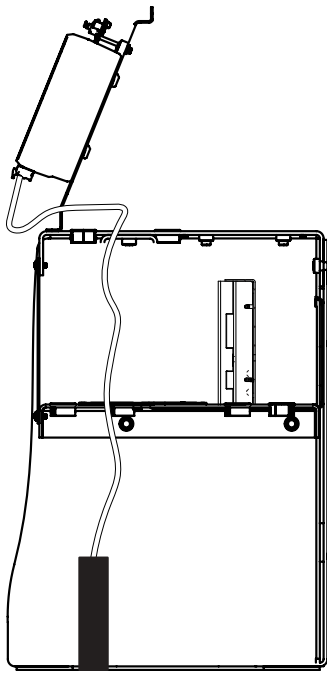

Figure 47. Route Relay Wires

4. Press MENU on the SmartTouch 725 Controller.

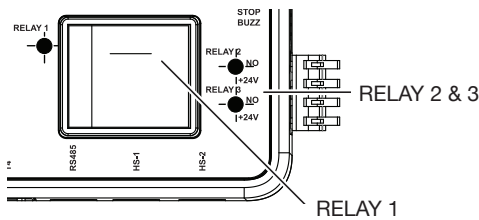
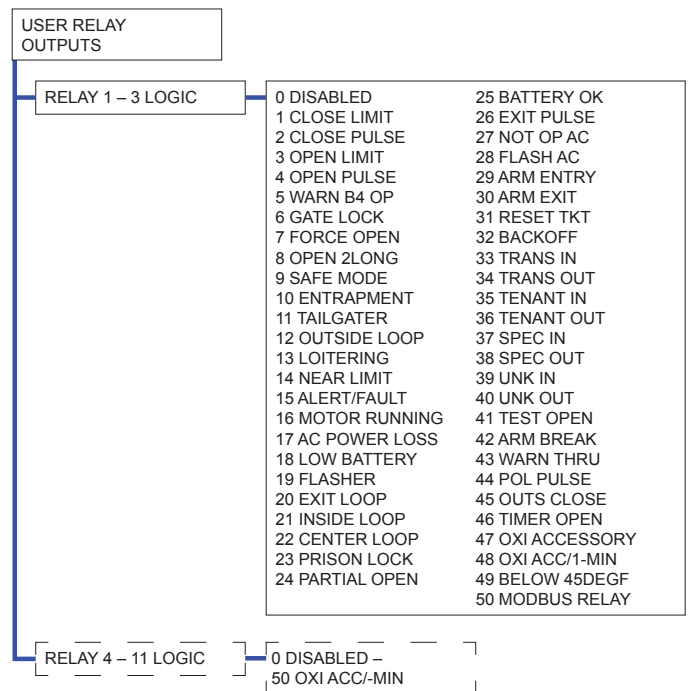
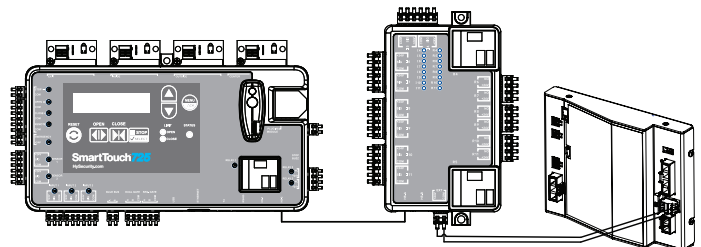

Figure 48. Relay Ports

5. Press the UP or DOWN arrow to navigate to USER RELAY OUTPUTS, press SELECT,
6. Press the UP or DOWN arrow to navigate to RELAY LOGIC, press SELECT.
7. Press the UP or DOWN arrow to highlight the appropriate setting, press SELECT.
8. Press BACK until the SmartTouch 725 controller resets and operator status displays.



RELAY 4 - 11 ARE VISIBLE AND CONFIGURABLE ONLY WITH OPTIONAL I/O EXPANSION MODULE WHICH CONNECTS VIA COMMUNICATION CABLE (MX4330 IN THE I/O EXPANSION MODULE KIT) FROM HS-2 ON THE SMARTTOUCH 725 CONTROLLER TO HS-A ON THE I/O EXPANSION MODULE



•Accessory power limited to 2A at 24VDC.

•Relay Ratings: (1) Mechanical 20A max at 240VAC (Figure 48 Relay 1). (2) Solid State relays 30VDC, 2A max (Figure 48 Relay 2 & 3).

OXI MegaCode Receiver and Programming

Note: The button on the OXI is not needed for programming fobs for the SmartTouch 725 and should not be pressed during the following installation processes.

Install and enable the receiver:

1. Remove the receiver port rubber plug. (Figure 49)
2. Install the receiver. (Figure 50)
3. Install a whip or coaxial antenna into the receiver antenna terminal for better range. Mount any external antenna onto the top of a fixed fence post near the operator.
4. Press MENU on the SmartTouch 725 Controller.
5. Press the UP or DOWN arrow to navigate to EXTERNAL COMMUNICATIONS and press SELECT.
6. Press the UP or DOWN arrow to navigate to OXI RADIO MENU OPTIONS and press SELECT.
7. Press the UP or DOWN arrow to navigate to ENABLE and press SELECT.
8. Press the UP or DOWN arrow to select ON and press SELECT.

Pair a fob:

1. Open OXI RADIO MENU OPTIONS (steps 4 - 6 to install receiver).
2. Press the UP or DOWN arrow to navigate to KEY FOB PAIRING and press SELECT.
3. Press the UP or DOWN arrow to select the function.
4. Press and hold the appropriate button on the fob.
5. Press SELECT. Display will beep and state PAIRED.
6. Repeat steps 2-5 to pair additional fob buttons or fobs.
7. Press MENU until gate status displays.
8. Press the buttons on the fob to test operation.

Remove a single fob in hand:

1. Open OXI RADIO MENU OPTIONS (steps 4 - 6 to install receiver).
2. Press the UP or DOWN arrow to navigate to KEY FOB REMOVAL and press SELECT.
3. Press the UP or DOWN arrow to select 1 (ON).
4. Press and hold the button on the fob and press SELECT to remove.
5. Repeat steps 3 and 4 for every fob button to be removed.

Remove a single fob from a list:

Note: It is important to keep a log of fobs and who is responsible for each for this method.

1. Open OXI RADIO MENU OPTIONS (steps 4 - 6 to install receiver).
2. Press the UP or DOWN arrow to navigate to KEY FOB LIST and press SELECT.
3. Press the UP or DOWN arrow to navigate to the fob number in the list and press SELECT.
4. Press the UP or DOWN arrow to select Y and press SELECT. This removes the fob.

Remove all fobs:

1. Open OXI RADIO MENU OPTIONS (steps 4 - 6 to install receiver).
2. Press the UP or DOWN arrow to navigate to REMOVE ALL KEYS and press SELECT
3. Change the setting to 1 (YES) and press SELECT.

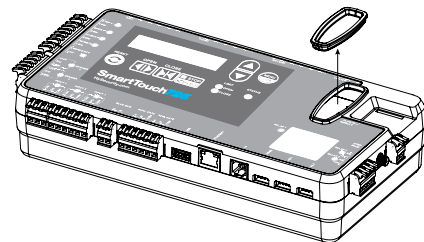

Figure 49. Remove OXI Receive Port Rubber Plug

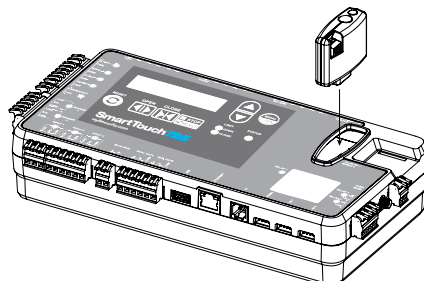

Figure 50. Install OXI Receiver

Connect to the HySecurity Installer APP

Set bluetooth Switch:

1. Set the DC and AC switches to OFF.
2. Remove the rubber plug or OXI receiver from OXI receiver slot (Figure 51).
3. Move the switch to the ON position. (Figure 52).
4. Place the rubber plug in the OXI receiver slot.

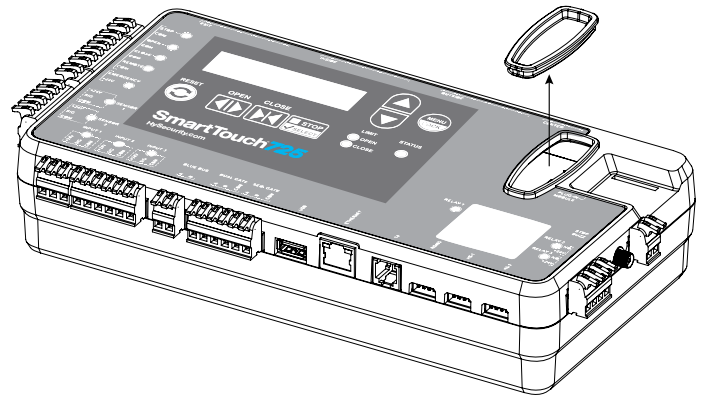

Figure 51. Remove OXI Receiver Cover

Enable bluetooth in the menus:

5. Set the DC and AC Switches to ON.
6. Press MENU on the SmartTouch 725 controller.
7. Press the UP or DOWN arrow to navigate to EXTERNAL COMMUNICATIONS and press SELECT.
8. Press the UP or DOWN arrow to navigate to BLUETOOTH OPTIONS MENU and press SELECT.
9. Press the UP or DOWN arrow to select 1 (ON) and press SELECT.
10. Press the UP or DOWN arrow to show BLE PIN and GATE NAME. Record the PIN and GATE NAME.



Figure 52. Bluetooth Switch

Connect the app and controller:

11. Open the HySecurity Installer App. Always keep the app up-to-date.
12. Tap Connect.
13. Tap the name of the appropriate operator.
14. Enter the PIN from step 10.
15. Connect button changes color to green to indicate good connection.



Figure 53. Bluetooth Enabled Display

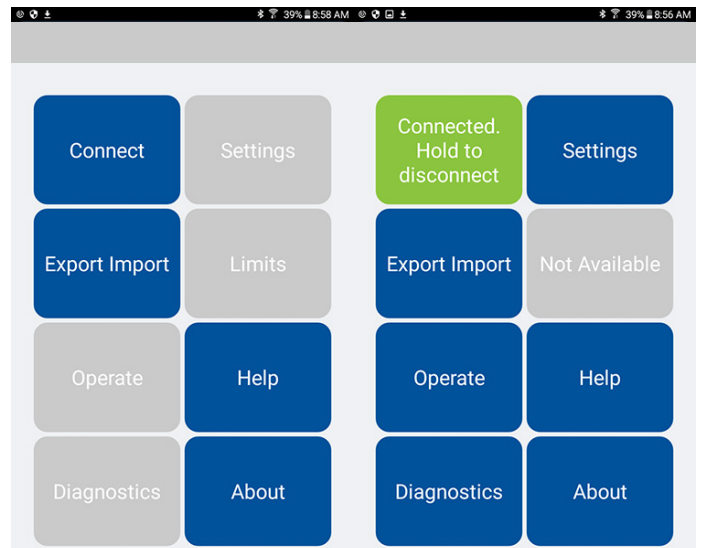

Figure 54. HySecurity Installer App Connect and Disconnect

Note: For improved security BLE is automatically disabled at midnight. Follow above steps to re-enable as needed.

Maintenance

MECHANICAL MAINTENANCE

The SwingSmart 535 requires minimal mechanical maintenance. Check the following on a routine basis:

- Sweep debris out and away from the chassis.
- Check for signs of rust. If any areas of rust are found, reduce spread of corrosion by treating areas with a rust inhibitor.
- Check for wear on taper clamp. Verify limits are set correctly per instructions on page 21 to avoid collision with physical stops which causes unnecessary taper clamp slip. Replace if required.
- Verify condition of swing arm elbow joint.
- Check for damage due to gate strikes. Replace bushings if required. Check the gearbox for leaks.
- Grease swivel joint at gate attachment point.
- Replace worn-out batteries. Refer to "DC Battery Replacement" on page 37.

FUSE REPLACEMENT

A 30A fuse is located next to the battery harness. It requires no maintenance, but if blown due to a power surge, swap it out with a new fuse (Figure 55). ALERT 28 BATT DISCONNECTED indicates a blown fuse or disconnected batteries.

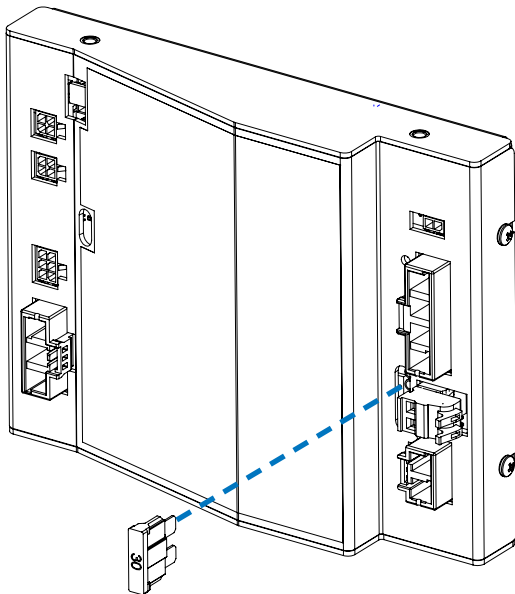

Figure 55. Fuse Replacement

Note: See Advanced Manual for more information.

DC BATTERY REPLACEMENT

Nice provides a one year warranty from the date of shipment for all batteries supplied with the SwingSmart 535 operator.

Display indicators of a low battery include:

- LOW BATTERY or DEAD BATTERY
- ALERT 18 - CHANGE BATTERY
- ALERT 28 - DISCONNECTED BATTERIES. Gate operation is affected by AC power loss.

The two 8Ah batteries are located on the left hand side of the power shelf behind power shelf cover.

To replace the batteries:

1. Remove the front cover.
2. Set the DC and AC power switches to OFF.
3. Remove the power shelf cover.
4. Cut the zip ties on the batteries.
5. Disconnect the blue jumper wire, disconnect the wire harness, and remove the 8Ah batteries.

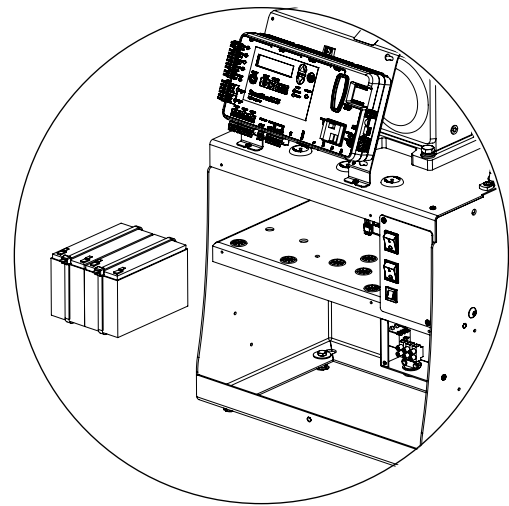

Figure 56. Remove the Batteries

6. Install the new batteries.
7. Connect the red harness wire to the red terminal on left battery.
8. Connect the blue harness wire to the black terminal on the right battery.
9. Connect the blue jumper wire between the batteries.
10. Set the AC and DC switches to ON and replace the front cover.

Note: Properly dispose of used batteries.

Firmware Updates and Debug Data

Download the firmware to a USB drive:

1. Go to support.hysecurity.com, click on Software, click SmartTouch 725 Code h6.##, and click h6.##.cnx to download the firmware file.

2. Connect a USB drive to your computer.

Note: FAT32 is the preferred file system for USB drives used for firmware updates.

3. Navigate to the download folder with the .cnx file.
4. Copy the .cnx file to the root folder of the USB drive.
5. Properly disconnect the USB drive.

Install the firmware:

1. Move the gate to the open position to allow free flow of traffic. The SmartTouch 725 Controller ignores all inputs and outputs during the firmware update.
2. Plug the USB drive into the USB port on the SmartTouch 725 Controller (Figure 57).
3. Press SELECT when USB OPTIONS MENU appears.
4. Press the UP or DOWN arrow to LOAD SW and press SELECT.
5. Press the UP or DOWN arrow to YES and press SELECT.
6. The display shows LOADING FW while the firmware loads. It could take up to 10 minutes to load the firmware.

NOTICE

Do not shut off power. Do not remove the USB or HSP1 communication cable during download. This can cause SmartTouch 725 Controller communication to stop and requires a SmartTouch 725 Controller replacement.

7. The display shows COMPLETE and the controller beeps once when software loading ends.
8. Remove the USB drive.

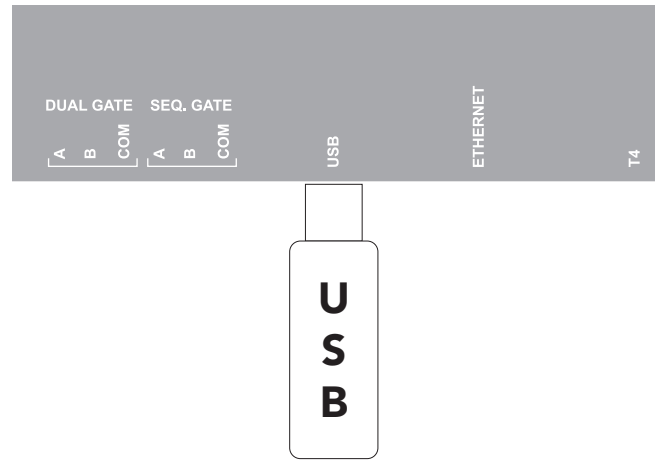
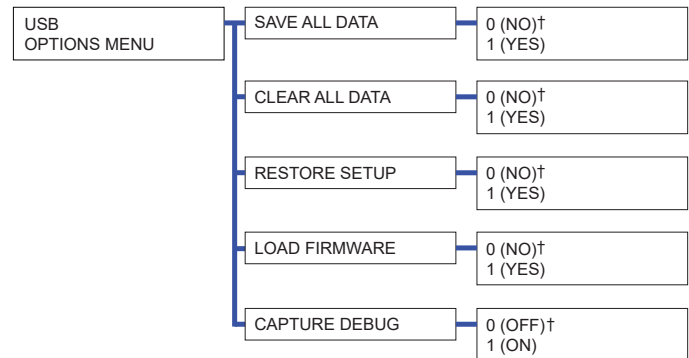

Figure 57. USB Port



SAVE ALL DATA save the event log data, any stored debug data events, and the menu setup file.

CLEAR ALL DATA clears the event log and any stored debug data.

RESTORE SETUP loads a saved menu setup file onto a new SmartTouch 725 controller or operator.

LOAD FIRMWARE loads new firmware after plugging in a USB drive with firmware for updates.

CAPTURE DEBUG saves real time debug data onto a USB drive until the setting is changed to 0 (OFF) or the stop button is pressed. The debug data can be used to determine if there are any intermittent input activations.

† = Indicates default

Troubleshooting/Alerts/Faults/Errors

Table 8. SmartTouch 725 Controller - Troubleshooting

Display Condition	Description Alert, Error or Fault	Possible Causes	Solutions
SAFE MODE	Safe Mode Alert	Occurs when an edge sensor or Inherent Entrapment Sensor (IES) trips. Gate binding, wind, or a faulty edge sensor can cause a false alert. All inputs are still functional during safe mode, but Close Timer is disabled until an operate command is received.	<ol style="list-style-type: none"> 1. Activate any operate command. 2. Remove obstruction. 3. Correct gate hardware. 4. Correct faulty edge sensor. 5. Adjust IES sensitivity.
ENTRAPMENT MODE	Entrapment Mode Alert	<p>Occurs when IES is tripped when gate is already in Safe Mode (two IES trips in one cycle). Operator will not function until it is reset, which can occur by:</p> <ul style="list-style-type: none"> • An Open or Stop command from a push-button control • Pressing STOP button on operator side • Pressing RESET button below display <p>Gate binding, wind, or a faulty edge sensor can cause a false alert. Emergency Close or Fire Open input activation will also stop the gate in Entrapment Mode.</p>	Refer to solutions above.
NO AC POWER	No AC Input Power Advisory only.	AC power is shut off at source (breaker) or is not connected. AC power switch on operator (lower rocker switch) is turned off, or circuit breaker on the operator has tripped. Failed power supply. Power supply selector switch is in the wrong position. May appear on a solar powered operator when there is not enough power output from the panel.	<ol style="list-style-type: none"> 1. Verify Voltage Selector switch is set for the supplied voltage. 2. Set AC switch to On. 3. Reset operator circuit breaker or reset circuit breaker at electrical panel. 4. Verify AC power to operator. Have a licensed electrician check wiring. 5. Check power supply output is 36VDC.
LOADING FW	Firmware is being loaded into SmartTouch 725 Controller.	Firmware is currently being loaded. Display will show which specific processor firmware is loading.	Wait for firmware to finish loading.

Troubleshooting/Alerts/Faults/Errors

Table 9. SmartTouch 725 Controller - Troubleshooting

Display Condition	Description Alert, Error or Fault	Possible Causes	Solutions
LOW 24VDC	Low 24VDC UPS Batteries Advisory only.	Occurs when battery voltage has dropped to less than 22V. At this level, batteries have about 20% charge. Normal function until 21V. <ul style="list-style-type: none"> No AC Power. Wiring / Connector problem Drive module charger failure Power supply failure 	<ol style="list-style-type: none"> Verify AC power. Check all connections. Clean or repair as required. Check battery condition and replace as required. Check charger voltage is 27VDC at red/blue battery wires. Replace drive controller. Verify power supply voltage of 36VDC and replace as required.
DEAD BATTERY	Extremely low UPS batteries – no automatic operation - batteries below 21V.	Occurs when battery voltage has dropped to less than 21V. At this level, batteries have about 10% charge. Gate will automatically open or close depending upon setting chosen. No additional automatic function is possible, but limited push button control is available down to 18V.	Refer to solutions above.
HYSECURITY BAD POWER	Critically low 24V supply power. This message can occur only on initial start up if power is critically low.	DC power is below 14V – no control functions will be allowed at all.	Refer to solutions above.
No display, LED blinking	SmartTouch 725 Controller is receiving power, but battery voltage is very low or operator may be in standby mode.	Several possible causes: <ul style="list-style-type: none"> Operator in standby mode. AC power has been shut off from the operator for too long and the batteries are drained. Wiring problem. Batteries no longer hold a charge. Failed SmartTouch 725 Controller. Failed power supply or drive module. Disconnected com (HSP) wire between SmartTouch 725 controller and drive module. 	<p>Press any button on controller</p> <p>Refer to solutions above.</p>

Troubleshooting/Alerts/Faults/Errors

Table 10. SmartTouch 725 Controller Controller - Alerts

Display Condition	Description Alert, Error or Fault	Possible Causes	Solutions
ALERT 1 FORCE OPEN	Gate forced open. Alarm will sound.	Gate has been forced off the full close limit and is being prevented from re-closing.	Will self-clear after an open or close input.
ALERT 2 DRIFT CLOSED	Gate drifted closed.	Gate has drifted off the full open limit and is being prevented from re-opening.	Will self-clear after an open or close input.
ALERT 4 THERMAL OVERLOAD	Thermal overload alert. When alert is triggered, gate can only “fully open” until alert is cleared.	Motor drive exceeds 212°F. Alert temporarily disables operator, but automatically resets itself when it cools down. May also occur if the heatsink temperature is 70°F higher than ambient temperature.	Check gate hardware. Alert automatically clears when temperature drops below threshold.
ALERT 5 BOTH LIM ACTIVE	Both limit sensors are on at the same time	<ul style="list-style-type: none"> • Short in wiring or drive module connection • Failed limit sensor • limit sensors unplugged from drive board 	<ol style="list-style-type: none"> 1. Repair any wiring issues. 2. Check limit sensors and replace as required.
ALERT 6 LIM NOT RELEASED (Swing only)	The limit did not release when the operator was commanded to move.	<ul style="list-style-type: none"> • Loose taper clamp. • Arm assembly binding. • Failed limit switch 	<ol style="list-style-type: none"> 1. Tighten taper clamp 2. Check limit sensors and replace as required 3. Verify arm condition
ALERT 7 FREQ SHIFT FAULT*	Hy5B detects a frequency change outside normal range.	Likely causes are poor integrity of loops or metallic objects within range.	Check lead and roadway loop wires for problems. Replace if necessary.
ALERT 8 LOOP SHORTED*	Hy5B detects a loop shorted to ground.	Caused by inadequate insulation of loop wires.	Refer to solution above.
ALERT 9 LOOP OPEN*	Hy5B detects a lack of continuity in loop wire.	Caused by broken loop wire or wire has come unplugged from detector.	Refer to solution above.
ALERT 10 I2C BUS ERROR*	Communication error detected to a Hy5B vehicle detector.	Caused by removal of Hy5B or lack of integrity of socket connection.	Remove and re-install the Hy5B and press RESET. Replace Hy5B, if necessary.
ALERT 11 DETECTOR FAULT*	A problem detected within an Hy5B vehicle detector.	Caused by a fault within Hy5B.	Remove and re-install the Hy5B and press RESET. Replace Hy5B, if necessary.
ALERT 12 ON TOO LONG*	An input loop (Hy5B or box detector output) is active for more than 5 minutes.	Caused when SmartTouch 725 Controller sees an active loop for more than 5 minutes. “Active” loop can be actual or false.	Check traffic patterns at site. Loop and lead in wires should be checked for problems or replaced.

* This message will also indicate which detector the alert applies to: Exit Loop (ELD), Inside Obstruction Loop (IOLD), Outside Obstruction Loop (OOLD), or Center Loop (CLD).

Troubleshooting/Alerts/Faults/Errors

Table 11. SmartTouch 725 Controller Controller - Alerts

Display Condition	Description Alert, Error or Fault	Possible Causes	Solutions
ALERT 13 STIFF GATE	A gate takes more power to move over time.	Caused by degrading gate hardware or debris in track. This alert appears in history log. It does not have any effect with regard to opening or closing gate.	Check and correct gate hardware as required.
ALERT 14 STUCK GATE	The gate cannot move at all.	Caused by broken gate hardware or ice/snow buildup.	Check and correct gate hardware as required. Clear ice and snow.
ALERT 15 MISSED LIMIT (Slide Only)	Limit magnet is missing or is not detected.	Limit magnet fell off or target sensor wires are damaged. Limit magnet may not be installed correctly.	<ol style="list-style-type: none"> 1. Make sure limit magnet is properly fastened. 2. Check limit sensor to make sure it is reading magnet. 3. Change sensor if it or its wires are damaged.
ALERT 18 CHANGE BATTERY	24VDC UPS batteries need to be replaced. Buzzer will chirp every minute until UPS batteries are replaced.	Batteries are not taking a charge properly.	Replace the 24VDC UPS batteries
ALERT 22 INTLOCK FAILURE	Interlock/Sequential Gate communication lost. Alert auto clears when communication between two operators is restored.	<ul style="list-style-type: none"> • Appears when communication connection is lost for more than 5 seconds between interlocked or sequenced gate operators. • Solo operator has Sequential gate set to ON. 	<ol style="list-style-type: none"> 1. Check cable connections and wiring. Make sure both operators are working properly with same, current software versions. 2. Verify Dual Gate and Sequential Gate are both set to (0) on a solo operator.

* This message will also indicate which detector the alert applies to: Exit Loop (ELD), Inside Obstruction Loop (IOLD), Outside Obstruction Loop (OOLD), or Center Loop (CLD).

Troubleshooting/Alerts/Faults/Errors

Table 12. SmartTouch 725 Controller Controller - Alerts

Display Condition	Description Alert, Error or Fault	Possible Causes	Solutions
ALERT 28 BATTERY DISCONNECTED	Battery disconnected from drive module.	Dead or disconnected batteries detected by SmartTouch 725 Controller. Operator may still function on AC power but will not have battery backup. Battery fuse may be blown.	Replace or reconnect batteries. Replace fuse if needed.

Table 13. Smart 725 Controller - Faults

Display Condition	Description Alert, Error or Fault	Possible Causes	Solutions
FAULT 1 MOTOR RUN TIME (SWING ONLY)	The motor is on longer than the maximum run time selected.	<ul style="list-style-type: none"> Taper clamp slipping Missing target or failed limit sensor 	<ol style="list-style-type: none"> Tighten taper clamp. Check limit sensors. Replace as required. Increase Max Run Timer.
FAULT 2 SENSOR or INPUT #	Learned BlueBus sensor is missing or not working.	<p>This fault can only occur if BlueBus sensor check fails.</p> <p>Display will show BlueBus device that is missing.</p>	<ol style="list-style-type: none"> Check learned BlueBus sensors are connected. Correct malfunctioning sensor.
FAULT 4 GATE NO LOAD	SmartTouch 725 Controller detects no load on operator. Gate is non-operational while this fault is triggered.	<ul style="list-style-type: none"> Motor wires disconnected. DC switch off. Drive board may have failed. Motor may be damaged or faulty. 	<ol style="list-style-type: none"> Check DC motor wires condition and connection to drive module. Turn DC power switch on. Tighten taper clamp. Press RESET to clear fault.
FAULT 14 STUCK GATE	SmartTouch 725 Controller could not overcome stuck gate after 3 attempts. Gate is non-operational while this fault is triggered.	Caused by broken gate hardware or ice/snow buildup. No movement was detected by motor encoder	<ol style="list-style-type: none"> Check and correct gate hardware as required. Press RESET to clear fault. Make sure that motor wires are connected.

Troubleshooting/Alerts/Faults/Errors

Table 14. SmartTouch 725 Controller - Errors

Display Condition	Description Alert, Error or Fault	Possible Causes	Solutions
ERROR 1 DIRECTION ERROR	SmartTouch 725 Controller detects operator ran in wrong direction.	Limit sensor plugs switched on drive module.	<ol style="list-style-type: none"> 1. Switch limit sensor plugs or reset operator handing Left Hand/ Right Hand. 2. Press RESET to clear fault.
ERROR 3 Hy5B FAILED*	SmartTouch 725 Controller detects communication error with a Hy5B vehicle detector.	Caused by Hy5B removal or socket connection integrity.	<ol style="list-style-type: none"> 1. Press RESET. 2. Remove and re-install Hy5B. 3. Replace Hy5B, if needed.
ERROR 4 Dual Gate COMM	SmartTouch 725 Controller detects a communication error between primary and secondary in a dual gate installation.	<p>Several possible causes:</p> <ul style="list-style-type: none"> • Primary/Secondary communication cable is installed incorrectly. • Primary/Secondary not configured properly through Installer Menu. • Operator is not properly earth grounded. • Primary/Secondary communication cable installed in same conduit as high-voltage AC power. • One operator is powered off. • Different software versions between operators. Check software version currently loaded in operator by pressing RESET. 	<ol style="list-style-type: none"> 1. Correct communication cable. 2. Verify one operator is set as Primary and the other is set as Secondary. 3. Install ground rod per NEC/NFPA standard. 4. Install communication cables in a low voltage conduit. 5. Ensure AC power is present at both operators and all power switches are On. 6. Make sure both operators are running same software version.
ERROR 5 No display	Display is blank, but the error appears in the log and means that SmartTouch 725 Controller detected a serious internal error.	Internal software/hardware error. Report any instance of this error to HySecurity Technical Support.	<ol style="list-style-type: none"> 1. Set AC & DC switches to OFF and then to ON. 2. Update to latest firmware version. 3. Replace SmartTouch 725 Controller.

* This message will also indicate which detector the alert applies to: Exit Loop (ELD), Inside Obstruction Loop (IOLD), Outside Obstruction Loop (OOLD), or Center Loop (CLD).

Troubleshooting/Alerts/Faults/Errors

Table 15. SmartTouch 725 Controller - Errors

Display Condition	Description Alert, Error or Fault	Possible Causes	Solutions
ERROR 6 DRIVE BOARD COMM	Indicates communication failure between drive module and SmartTouch 725 Controller.	Drive module communication failed or the drive module may have failed.	<ol style="list-style-type: none"> 1. Update controller firmware to latest version. 2. Verify connection between SmartTouch 725 Controller and drive module (HSP1). 3. Replace drive module.
ERROR 7 MENU CHECKSUM	Firmware issue exists that may require factory reset.	Corrupt firmware or data.	Call Nice Technical Support for assistance.
ERROR 8 RPM SENSOR	RPM sensor disconnected.	Motor Encoder or wires are damaged or unplugged.	Check wiring from motor to drive module.
ERROR 9 BATTERY DISCONNECT	SmartTouch 725 Controller detects no battery connected.	<p>Batteries are disconnected, or a wiring fault exists.</p> <p>Only appears when the batteries are disconnected and the only input power is solar panels.</p>	<ol style="list-style-type: none"> 1. Connect battery harness to drive module. 2. Correct any issues with battery wiring. 3. Check fuse on drive module.

Table 16. BLDC Drive Board Status LEDs

Status LED 1	Status LED 2	Status LED 3	Status LED 4	Description	Operator Fault
ON	ON	ON	BLINK	All Systems Normal	None
OFF	OFF	OFF	OFF	Main Microprocessor Not Running	Error-6 Drive board firmware may be corrupt. Call Tech Support.
ON	OFF	ON	BLINK	Motor Drive Communication Fault	Error-6 Drive board firmware fault. Call Tech Support.
OFF	ON	ON	BLINK	Not Implemented	Not Implemented
ON	ON	OFF	BLINK	No Communication with SmartTouch 725 board	Error-6 Communication issue with drive board. Check cable connections between boards.

Appendix - Vehicle Detector Loops

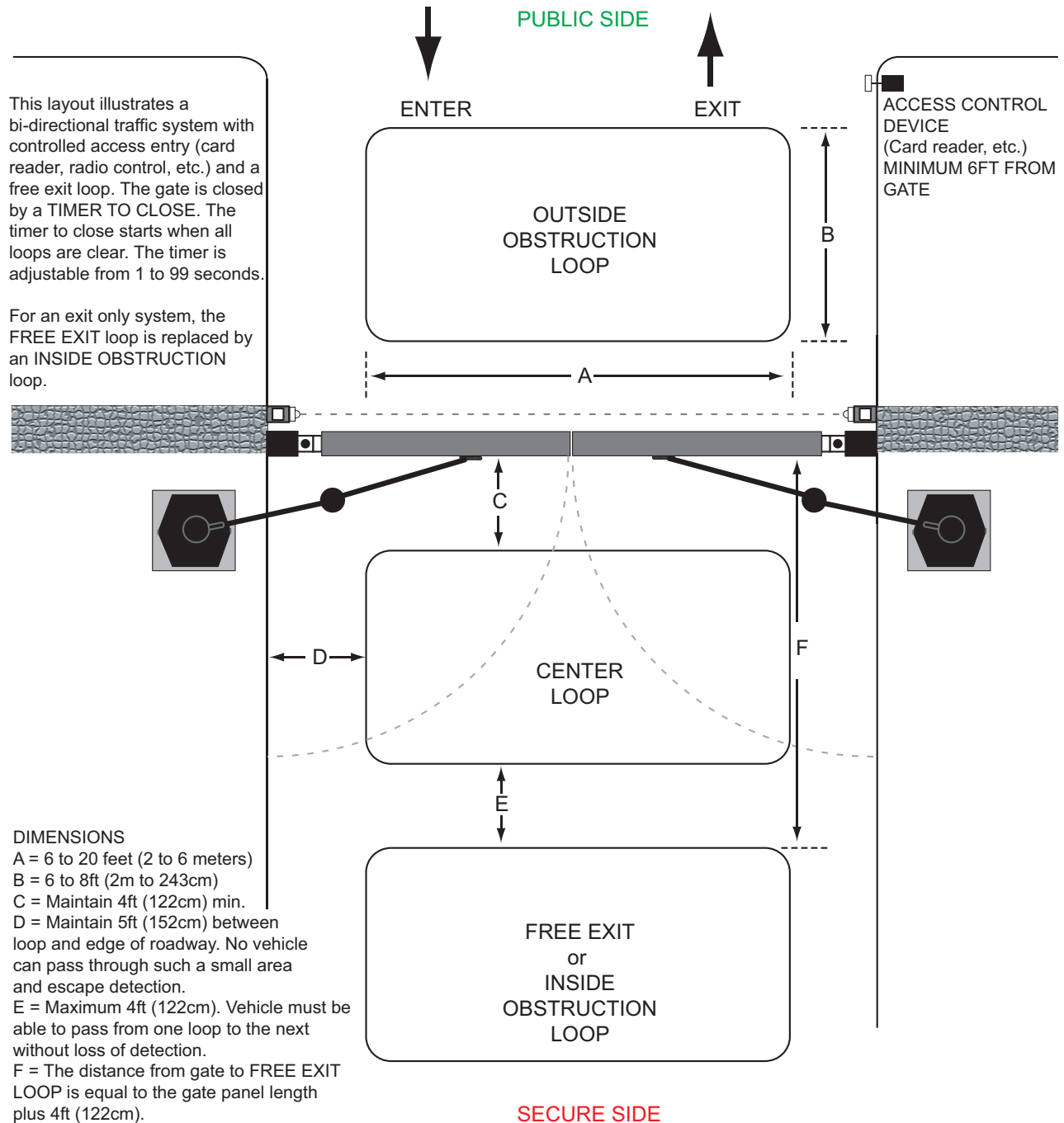

Vehicle Detectors and Loop Layout for Dual Gate Openings less than 28 feet* or Single Gate Openings less than 20 feet*

* NOTE: A minimum of three (3) detectors are required for this type of gate.

Appendix - Vehicle Detector Loops

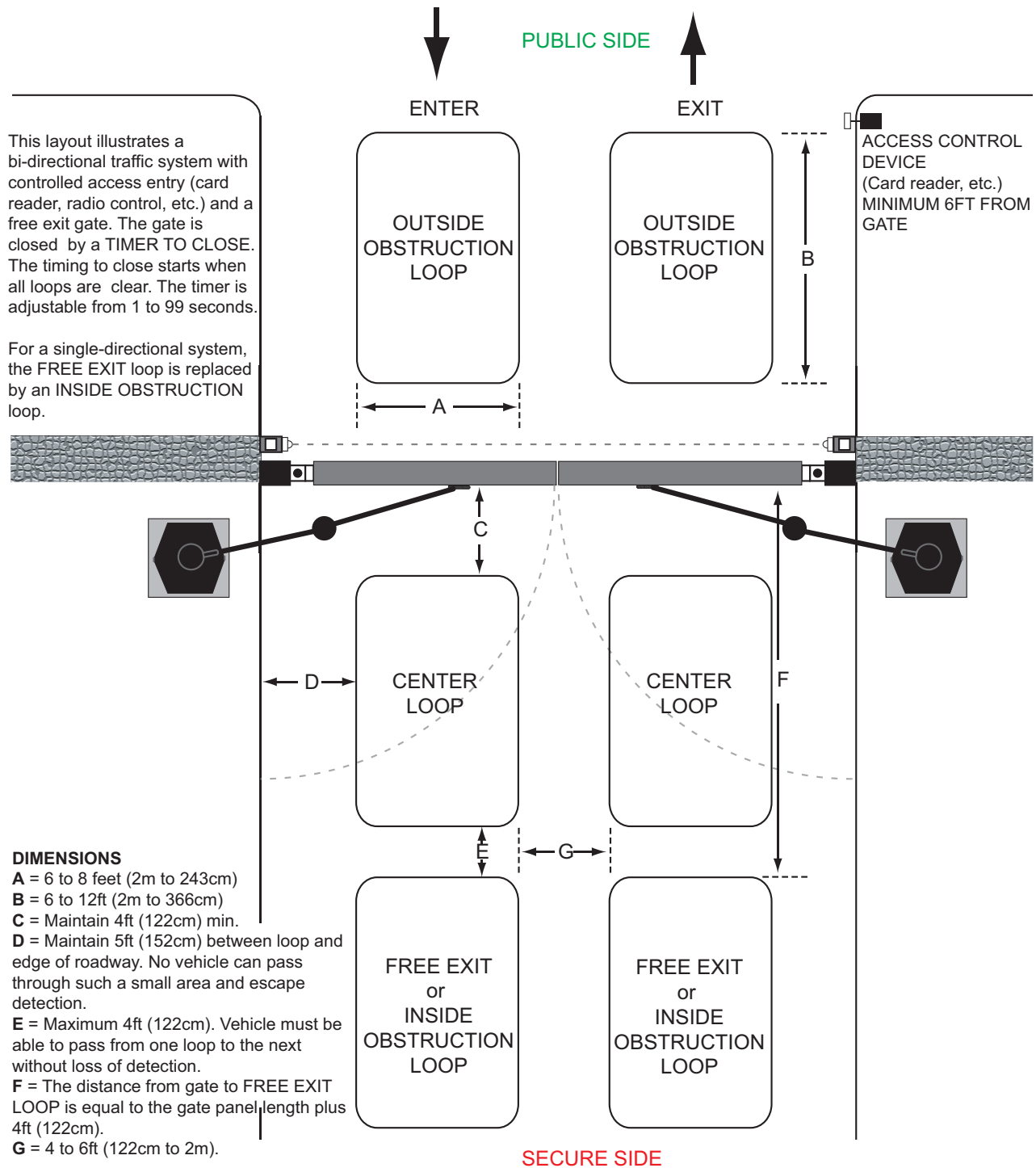

Vehicle Detectors and Loop Layout for Openings greater than 28 feet*

* NOTE: A minimum of three (3) detectors are required for this type of gate.

Appendix B - French Translations

FRENCH TRANSLATIONS

The following French translations provided below are found in the Safety Section located at the beginning of the manual.

English	French
<p>IMPORTANT SAFETY INSTRUCTIONS WARNING – To reduce the risk of injury or death:</p>	<p>INSTRUCTIONS DE SÉCURITÉ IMPORTANTES AVERTISSEMENT – Pour réduire les risques de blessures et de mort :</p>
<p>1. READ AND FOLLOW ALL INSTRUCTIONS.</p>	<p>1. LISEZ CETTE NOTICE ET CONFORMEZ-VOUS AUX MISES EN GARDE</p>
<p>2. Never let children operate or play with gate controls. Keep the remote control away from children.</p>	<p>2. Ne laissez jamais les enfants manoeuvrer les commandes de la barrière ou jouer avec celles-ci. Laissez la télécommande hors de la portée des enfants.</p>
<p>3. Always keep people and objects away from the gate. NO ONE SHOULD CROSS THE PATH OF THE MOVING GATE.</p>	<p>3. Tenez toujours à l'écart de la barrière toute personne ou tout objet avoisinant. IL NE FAUT JAMAIS PASSER DANS LA TRAJECTOIRE D'UNE BARRIÈRE EN MOUVEMENT.</p>
<p>4. Test the gate operator monthly. The gate MUST reverse on contact with a rigid object or stop when an object activates the non-contact sensors. After adjusting the force or the limit of travel, retest the gate operator. Failure to adjust and retest the gate operator properly can increase the risk of injury or death.</p>	<p>4. Vérifiez le fonctionnement de l'ouvre-barrière une fois par mois. Le sens de la course DOIT s'inverser lorsque la barrière entre en contact avec un objet dur ou la barrière DOIT s'arrêter lorsqu'un objet active les capteurs sans contact. Vérifiez à nouveau l'ouvre-barrière après tout réglage de la force de déclenchement ou du seuil de fin de course. Un réglage incorrect de l'ouvre-barrière ou l'omission de vérifier à nouveau le fonctionnement de l'ouvre-barrière peut causer des blessures, voire la mort.</p>
<p>5. Use the emergency release only when the gate is not moving.</p>	<p>5. Ne déclenchez le dispositif de désaccouplement d'urgence que lorsque la barrière ne bouge pas.</p>
<p>6. KEEP GATES PROPERLY MAINTAINED. Read the user's manual. Have a qualified service person make repairs to gate hardware.</p>	<p>6. ASSUREZ-VOUS QUE LA BARRIÈRE EST CORRECTEMENT ENTRETENUE. Lisez le manuel de l'utilisateur. Confiez la réparation du matériel de la barrière à un technicien qualifié.</p>
<p>7. The entrance is for vehicles only. Pedestrians must use separate entrance.</p>	<p>7. La voie d'accès est réservée aux véhicules seulement. Les piétons doivent utiliser une voie d'accès différente.</p>

Appendix B - French Translations

English	French
8. SAVE THESE INSTRUCTIONS.	8. CONSERVEZ CES INSTRUCTIONS.

English	French
2.3 Install the gate operator only when:	2.3 N'installez l'ouvre-barrière que si :
a. The operator is appropriate for the construction of the gate and the usage Class of the gate,	a. l'ouvre-barrière est approprié pour la structure et la classe d'utilisation de la barrière;
b. All openings of a horizontal slide gate are guarded or screened from the bottom of the gate to a minimum of 1.83 m (6 ft) above the ground to prevent a 57.2 mm (2-1/4 inch) diameter sphere from passing through the openings anywhere in the gate, and in that portion of the adjacent fence that the gate covers in the open position,	toutes les ouvertures de la barrière coulissante sont protégées ou grillagées du bas de la porte jusqu'à un minimum de 1,83 m (6 pi) du sol si bien qu'une sphère de 57,2 mm (2 1/4 po) de diamètre ne peut passer par une ouverture au niveau de la barrière et de la portion de la clôture adjacente que la barrière couvre en position ouverte;
c. All exposed pinch points are eliminated or guarded, and	c. tous les points de pincement sont éliminés ou protégés;
d. Guarding is supplied for exposed rollers.	d. des protections sont fournies pour les galets exposés.
2.4 The operator is intended for installation only on gates used for vehicles. Pedestrians must be supplied with a separate access opening. The pedestrian access opening shall be designed to promote pedestrian usage. Locate the gate such that persons will not come in contact with the vehicular gate during the entire path of travel of the vehicular gate.	2.4 L'ouvre-barrière est destiné à n'être installé que sur des barrières utilisées pour les véhicules. Il faut fournir une autre voie d'accès aux piétons. La voie d'accès pour les piétons doit être conçue pour favoriser le passage des piétons. Placez la barrière de sorte que personne ne puisse entrer en contact avec la barrière pour les véhicules sur l'ensemble de sa trajectoire

Appendix B - French Translations

English	French
<p>2.5 The gate must be installed in a location so that enough clearance is supplied between the gate and adjacent structures when opening and closing to reduce the risk of entrapment. Swinging gates shall not open into public access areas.</p>	<p>c) Pour réduire les risques de coincement lors de l'ouverture et de la fermeture, la barrière doit être installée dans un endroit où la barrière et les structures avoisinantes sont suffisamment éloignées l'une de l'autre. Les barrières battantes ne doivent pas ouvrir dans une zone d'accès public.</p>
<p>2.6 The gate must be properly installed and work freely in both directions prior to the installation of the gate operator. Do not over-tighten the operator clutch or pressure relief valve to compensate for a damaged gate.</p>	<p>2.6 La barrière doit être bien installée et fonctionner librement dans les deux directions avant d'entreprendre l'installation de l'ouvre-barrière. Ne serrez pas trop l'embrayage ou la soupape de surpression de l'ouvre-barrière pour compenser une barrière endommagée.</p>
<p>2.7 Controls intended for user activation must be located at least 1.83 m (6 ft) away from any moving part of the gate and where the user is prevented from reaching over, under, around or through the gate to operate the controls. Exception: Emergency access controls only accessible by authorized personnel (e.g. fire, police, EMS) may be placed at any location in the line-of-sight of the gate.</p>	<p>2.7 Les commandes destinées à l'activation par l'utilisateur doivent être situées à au moins 1,83 m (6 pi) des pièces mobiles de la barrière et à un endroit où l'utilisateur ne peut pas atteindre les commandes par le dessus, par le dessous, par les côtés et au travers de la barrière. Exception : Les commandes d'accès d'urgence accessibles au personnel autorisé seulement (p. ex. pompier, policier, SMU) peuvent être placées à tout endroit dans le champ de visibilité de la barrière.</p>
<p>2.8 The Stop and/or Reset button must be located in the line of-sight of the gate. Activation of the reset control shall not cause the operator to start.</p>	<p>2.8 Le bouton d'arrêt, le bouton de réenclenchement ou ces deux boutons doivent être situés dans le champ de visibilité de la barrière. L'activation des commandes de réenclenchement ne doit pas mettre en marche l'ouvrebarrière.</p>
<p>2.9 A minimum of two (2) WARNING SIGNS shall be installed, in the area of the gate. Each placard is to be visible by persons located on the side of the gate on which the placard is installed.</p>	<p>2.9 Au moins deux panneaux de mise en garde doivent être installés dans la zone de la barrière. Chaque étiquette doit être visible des personnes situées de chaque côté de la barrière sur laquelle l'étiquette est installée.</p>
<p>2.10 For gate operators utilizing a non-contact sensor</p>	<p>2.10 Pour les ouvre-barrières qui fonctionnent avec des capteurs</p>
<p>a. See instructions on the placement of non-contact sensors for each Type of application,</p>	<p>a. Voir les instructions sur le positionnement des capteurs sans contact pour chaque type d'utilisation.</p>

Appendix B - French Translations

English	French
<p>b. Care shall be exercised to reduce the risk of nuisance tripping, such as when a vehicle, trips the sensor while the gate is still moving, and</p>	<p>b. Des précautions doivent être prises pour réduire les risques de déclenchement inutile, comme lorsqu'un véhicule déclenche le capteur alors que la barrière est encore en mouvement.</p>
<p>c. One or more non-contact sensors shall be located where the risk of entrapment or obstruction exists, such as the perimeter reachable by a moving gate or barrier.</p>	<p>c. Un capteur sans contact ou plus doit être situé où il existe un risque de coincement ou d'obstruction, comme dans l'espace que peut occuper la barrière lorsqu'elle est en mouvement.</p>
<p>2.11 For a gate operator utilizing a contact sensor</p>	<p>2.11 Pour les ouvre-barrières qui fonctionnent avec des capteurs</p>
<p>a. One or more contact sensors shall be located where the risk of entrapment or obstruction exists, such as at the leading edge, trailing edge, and postmounted both inside and outside of a vehicular horizontal slide gate.</p>	<p>a. Au moins un capteur de contact doit être situé où il existe un risque de coincement ou d'obstruction, comme sur le bord d'ouverture, sur le bord de fermeture et sur les poteaux montés sur l'intérieur ou l'extérieur d'une barrière coulissante pour véhicules.</p>
<p>b. A hardwired contact sensor shall be located and its wiring arranged so that the communication between the sensor and the gate operator is not subjected to mechanical damage.</p>	<p>b. Un capteur de contact doit être installé et câblé de sorte à éviter que la communication entre le capteur et l'ouvrebarrière soit gênée par des dommages mécaniques.</p>
<p>c. A wireless device such as one that transmits radio frequency (RF) signals to the gate operator for entrapment protection functions shall be located where the transmission of the signals are not obstructed or impeded by building structures, natural landscaping or similar obstruction. A wireless device shall function under the intended end-use conditions.</p>	<p>c. Un dispositif sans fil, comme un appareil qui transmet des signaux de radiofréquence (RF) à l'ouvre-barrière pour prévenir le coincement, doit être situé à un endroit où la transmission des signaux ne sera pas obstruée ou gênée par des structures, des arbres ou d'autres obstacles similaires. Un dispositif sans fil doit fonctionner selon les conditions d'utilisation finale prévues.</p>
<p>d. One or more contact sensors shall be located on the inside and outside leading edge of a swing gate. Additionally, if the bottom edge of a swing gate is greater than 152 mm (6 inches) but less than 406 mm (16 inches) above the ground at any point in its arc of travel, one or more contact sensors shall be located on the bottom edge.</p>	<p>d. Au moins un capteur de contact doit être situé sur les bords d'ouverture intérieur et extérieur d'une barrière battante. De plus, si le dessous d'une barrière battante est situé à plus de 152 mm (6 po) mais à moins de 406 mm (16 po) du sol à l'un des points de sa trajectoire, au moins un capteur de contact doit être situé sur le bord inférieur.</p>

Page intentionally left
blank.

Warranty

1. Warranty. Nice North America LLC ("Nice") warrants that at the time of sale each Nice or HySecurity -branded gate operator ("Product") that it sells will, in all material respects, conform to its then applicable specification and will be free from defects in material and manufacture.

The following additional durational warranties apply to Nice or HySecurity branded Product, depending on whether (1) the Product is purchased through an authorized distributor and (2) whether a timely and complete Product registration is submitted to Nice.

It is therefore important that you register your Product with Nice, online at www.hysecurity.com/warranty, within the 60-day period described below.

1(a) Nice Products Purchased Through Authorized Distributors and Properly Registered

For any gate operator Product that is purchased from an authorized Nice distributor (this excludes product purchased through internet resellers or any distributor not authorized by Nice), if the Product registration is completed by the Dealer/Installer or End User within 60 days of the date of purchase, the following warranty terms will apply. Nice warrants that the Product will remain serviceable under this warranty for the following periods:

- i) HySecurity brand hydraulic gate operator hydraulics, controls, and mechanical components: Five Years or 500,000 gate cycles (whichever occurs first) after the date of installation;
- ii) HySecurity hydraulic wedge operator hydraulics and controls: Five Years or 500,000 cycles (whichever occurs first) after the date of installation. Wedge mechanical components: Two Years after the date of installation;
- iii) Nice or HySecurity brand commercial grade electromechanical pad-mounted slide and swing operators such as SwingSmart 535 and SlideSmart 535: Five Years or 500,000 cycles (whichever occurs first) after the date of installation, except that commercial grade electromechanical pad-mounted slide and swing operators used for single family residential purposes shall have a warranty term of Seven Years after the date the product was shipped by Nice;
- iv) Nice brand residential grade pad mount swing and slide gate operators such as Juno and Vanguard 3501: Three years after the date of installation,
- v) Nice brand electromechanical linear actuator Swing operators: Three Years after the date of installation;
- vi) HySecurity electromechanical surface mount wedge operator electronics: Two Years or 500,000 gate cycles (whichever occurs first), after the date of installation;
- vii) Electromechanical barrier arm operators: Two years or 1,000,000 gate cycles (whichever occurs first) after the date of installation, provided that the preceding Five Year warranty period in (i), (ii), and (iii) above will not extend beyond seven years from the date that the product was shipped by Nice, and the Two Year warranty period in (ii), (iv), (v), and (vi) above will not extend beyond four years from the date that the product was shipped by Nice.

The preceding warranty durations do not apply to the products or components described below (viii-xi), which have a shorter warranty period:

- viii) Hydraulic gate operator drive wheels, including XtremeDrive™ wheels and rack: Two Years from date of installation;
- ix) AC and DC power supplies, chargers, and inverters: Two Years from date of installation, except batteries;
- x) Batteries: One Year from date of shipment by Nice;
- xi) Components subject to normal wear including, but not limited to, chains, belts, idler wheels, sprockets and fuses: One Year from date of installation.

1(b) Nice Products Not Purchased Through an Authorized Distributor or Not Properly Registered within 60 Days

For any Product that is not purchased from an authorized distributor or for which the Product registration was not completed by the Dealer/Installer/End User within sixty (60) days of the date of purchase, the following warranty will apply: Nice warrants that the Product will remain serviceable under this warranty for the following periods, which begin on the date that the Product was shipped by Nice:

- (i) All gate operators: One Year or 100,000 gate cycles, whichever occurs first.
- ii) AC and DC power supplies, chargers, or inverters: One Year from date of installation.
- iii) Hydraulic gate operator drive wheels: One Year from date of installation.

1(c) Replacement Parts

Nice warrants that replacement parts for Products (whether new or reconditioned) will remain serviceable under this warranty for One Year from the date that the part was shipped by Nice or the remaining period of the Product warranty, whichever is longer.

1(d) Limitations and Exclusions Applicable to Each of the Preceding Warranties.

The preceding warranties shall not apply to equipment that has been (1) installed, maintained, or used improperly or contrary to instructions; (2) subjected to negligence, accident, vandalism, or damaged by severe weather, wind, flood, fire, terrorism or war; or (3) damaged through improper operation, maintenance, storage or abnormal or extraordinary use or abuse. Any modification made to products will void the warranty unless the modifications are approved in writing by Nice in advance of the modification (this exclusion does not apply to normal installation of approved accessories and/or protective devices or sensors). It is the responsibility of the Distributor, Dealer/Installer, or End User to ensure that the software version in the product is maintained to the latest revision level.

The preceding warranties do not extend to accessories when those items carry another manufacturer's name plate and are not a part of the base model. Nice disclaims all warranties for such accessory components, which carry only the original warranty, if any, of their original manufacturer. Nice hereby assigns its rights under such manufacturer warranties—to the extent that such rights exist and are assignable—to Buyer.

The warranties made by Nice herein extend to Nice's Distributors, to the Dealer/Installer, and to the first End User of the product following installation. They do not extend to subsequent purchasers.

The warranties herein do not apply to Mighty Mule-branded products and components.

2. Exclusion of Other Warranties.

The warranties contained in Section 1 are the exclusive warranties given by Nice and supersede any prior, contrary or additional representations, whether oral or written. Any prior or extrinsic representations or agreements are discharged or nullified. NICE HEREBY DISCLAIMS AND EXCLUDES ALL OTHER WARRANTIES—WHETHER EXPRESS, IMPLIED, OR STATUTORY—INCLUDING ANY WARRANTY OF MERCHANTABILITY, ANY WARRANTY OF FITNESS FOR A PARTICULAR PURPOSE, ANY LIABILITY FOR INFRINGEMENT, AND ANY WARRANTIES OTHERWISE ARISING FROM COURSE OF DEALING, COURSE OF PERFORMANCE, OR USAGE OF TRADE.

3. Buyer's Exclusive Remedies for Any Nonconformity.

If a Nice Product fails to conform to the warranties in Section 1, Buyer must notify and order replacement parts from the Distributor through which the Product was purchased within a reasonable time and in no event more than thirty (30) days after the discovery of the nonconformity. Nice will investigate and, in the event of a breach, will provide, within a reasonable period of time, one of the following remedies to be selected by Nice in its sole and absolute discretion:

- (1) repair or replacement of any nonconforming Products or Product components or
- (2) refund of the price upon return of the nonconforming items. Nice reserves the right to supply used or reconditioned material for all warranty claims. Nice will not be considered to be in breach of or default under this Warranty because of any failure to perform due to conditions beyond its reasonable control, including any force majeure event. This warranty does not cover any incidental expenses, including fines or penalties, temporary security, labor, shipping, travel time or standby time that are incurred for inspection or replacement of any nonconforming items. As a condition of warranty coverage, warranty claims must be submitted in accordance with the procedures described on the Nice form, "RMA Procedures."

THE REMEDY SELECTED BY NICE IN ACCORDANCE WITH THIS PARAGRAPH SHALL BE THE EXCLUSIVE AND SOLE REMEDY OF BUYER FOR ANY BREACH OF WARRANTY.

4. Exclusion of Consequential and Incidental Damages.

NICE SHALL NOT BE LIABLE FOR ANY INCIDENTAL, SPECIAL, OR CONSEQUENTIAL DAMAGES, WHETHER RESULTING FROM NONDELIVERY OR FROM THE USE, MISUSE, OR INABILITY TO USE THE PRODUCT OR FROM DEFECTS IN THE

PRODUCT OR FROM NICE'S OWN NEGLIGENCE. This exclusion applies regardless of whether such damages are sought for breach of warranty, breach of contract, negligence, or strict liability. This exclusion does not apply to claims for bodily injury or death.

5. Severability.

If any provision of this warranty is found to be invalid or unenforceable, then the remainder shall have full force and effect.

6. Proprietary Rights.

Nice retains and reserves all right, title, and interest in the intellectual property rights of its products, including any accompanying proprietary software. No ownership of any intellectual property rights in the products or accompanying software is transferred to Distributor, Dealer/Installer, or End User.

7. Applicable Law.

This warranty will be interpreted, construed, and enforced in all respects in accordance with the laws of the State of Washington, without reference to its choice of law principles. The U.N. Convention on Contracts for the International Sale of Goods will not apply to this warranty.

Specifications

SwingSmart™ 535 model, AC or solar

Model	SwingSmart 535
Single or Twin	Single leaf
Duty Cycle	Continuous
Horsepower	Equivalent to 1/2 hp
Drive	Electromechanical - 24V Brushless DC motor with direct drive power train
Open/Close Time	Open/Close time set independently.
Gate Length Max.	20 ft (6 m) each leaf
Gate Weight Max.	1,300 lb (590 kg) for 12 ft (4 m) leaf; 800 lb (363 kg) for a 16 ft (5 m) leaf; 600 lb (272 kg) for a 20 ft (6 m) leaf
UPS Battery Backup Cycles	Field configurable to fail open or secure when batteries deplete. Standard battery backup gate travel: Two 12V 8Ah batteries. Up to 300 cycles after AC power loss. Extended battery backup gate travel: Two 12V 35Ah batteries. Up to 1,000 cycles after AC power loss.*
Temperature Rating	-13° to 158° F (-25° to 70° C)
Operating Voltage	24VDC
Input Voltage	Switch select 115V or 208-230V, 60/50 Hz; Solar: 24V solar panels †
Accessory Power	24VDC at each input & SS relay (2A accumulative)
Included Accessories	One Nice EPMOB through-beam photo eye with BlueBUS technology and two 8Ah batteries for backup power and OXI MegaCode receiver.
Communication	BlueBUS, USB, Ethernet, T4, RS-485, Bluetooth, OXI receiver
User Controls	SmartTouch 725 Controller with 70+ configurable settings. 32 character OLED display and 7 tactile buttons, or Bluetooth smartphone interface, for programming.
Inputs	15 inputs including 5 control inputs, 2 dedicated entrapment sensor inputs, 3 user programmable inputs, a BlueBUS port, and 4 Hy5B vehicle detectors sockets. Optional SmartTouch™ I/O Expansion module for 8 additional user programmable inputs.
Relays	3 configurable user relays: Two - 30VDC, 2A solid state. One 250VAC, 20A electromechanical; Optional SmartTouch I/O Expansion module for 8 additional relay outputs.
Finish	Zinc rich primer with black powder coated chassis. High impact copolymer cover.
ETL Listed (UL 325)	Usage Class I, II, III, IV
Warranty	5 year (7 year single-family residential) w/product registration

* The actual number of gate cycles available from battery depends upon gate resistance to travel, cycle length, battery size, state of charge and health, ambient temperature, accessory power draw and frequency of gate cycles during power outage.

Contact Information:

Visit support.hysecurity.com for Installation manuals, replacement part instructions, part diagrams and more.

Qualified Nice | HySecurity distributors are experienced and trained to assist in resolving installation problems. For the name of a qualified distributor near you, call HySecurity at 800-321-9947. *Before contacting your distributor or HySecurity Technical Support, obtain the serial number of your operator.



Technical Support

253-201-2918
Monday - Friday, 6:00 a.m. – 4:00 p.m. PST

Nice North America | HySecurity

Gate & Barrier Division
6705 S 209th St, Ste 101
Kent, WA, 980320



Niceforyou.com