

# SWINGSMART CNX TOP CAP SHIELD INSTRUCTIONS

## NOTICE

Failure to attach the top cap shield can allow water, dirt, sand, rodents, etc. to enter the operator and negatively affect operator function or cause failure.



## WARNING

Risk of electric shock. Do not handle electrical components when they are wet and energized.

1. Position the top cap shield underneath the operator arm.
2. Thread zip ties through slots in shield. (Figure 1)
3. Secure shield to underside of operator arm with zip ties. (Figure 2)
4. Trim the ends of the zip ties.
5. Slide the top cap shield against the opening in the back cover and then pull it away less than 1/8 inch. (Figure 3)
6. Center the top cap over the taper clamp and operator arm. (Figure 4)
7. Lock the top cap in place with the key. (Figure 5)

Zip Tie Channels  
in the Bottom of the  
Top Cap Shield

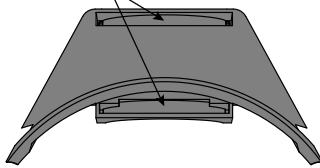

Figure 1. Zip Tie Channels

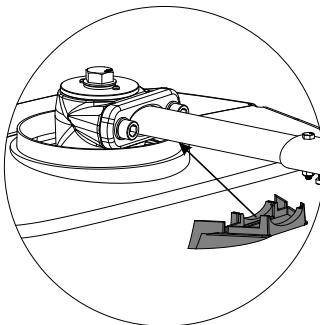

Figure 2. Position the Top Cap Shield

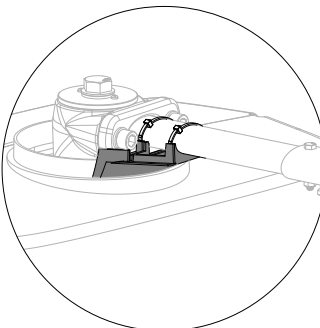

Figure 3. Wrap the Zip Ties Around the Arm

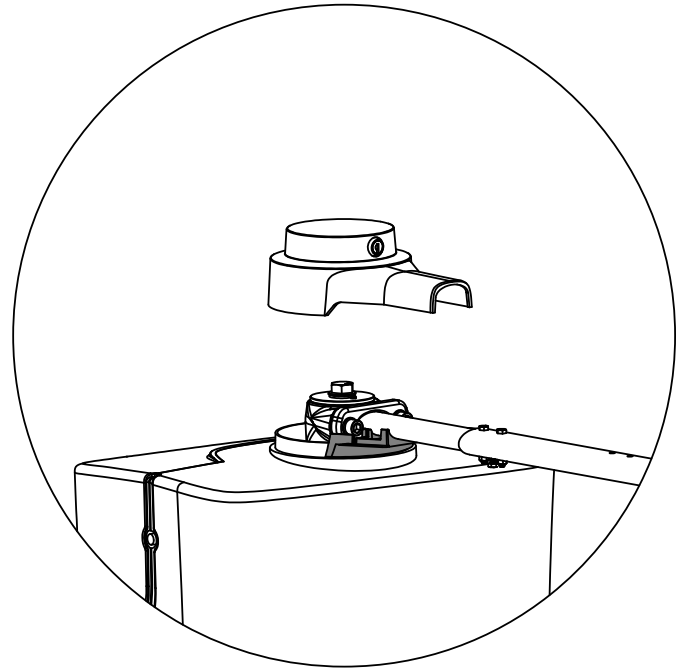

Figure 4. Center the Top Cap

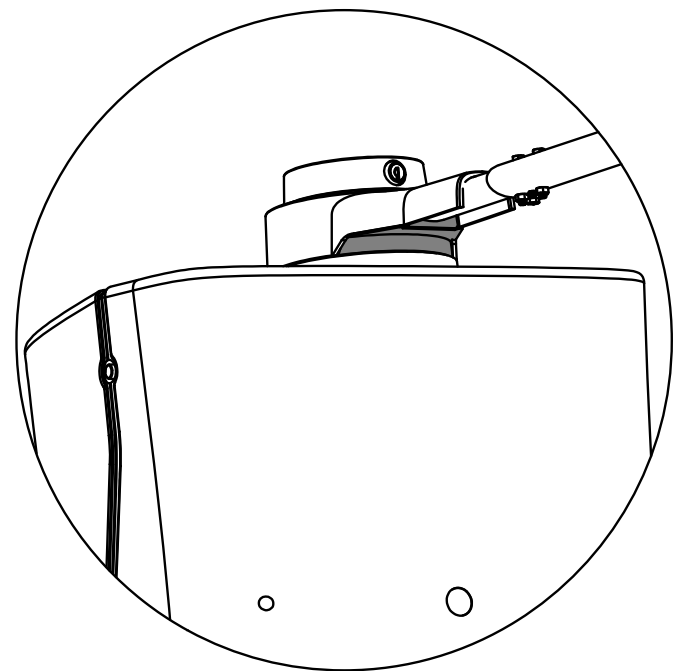

Figure 5. Lock the Top Cap In Place