

StrongArm M30/M50 Pump Pack

Several types of hydraulic pump packs are manufactured at HySecurity. These instructions pertain to the pump packs used in the M30/M50 Fortified CRASH Barrier Arm operators. The pump pack you receive may look different than the illustration on this page, but the steps involved in assembling and installing the pump pack are the same.

Items to note BEFORE you install the replacement pump pack include:

- When replacing a pump pack, it is important to check and verify that the pump pack assembly you received from HySecurity and the model being replaced are equivalent.
- The pump pack reservoir is filled with hydraulic fluid. You will need an extra vent plug to replace the breather cap on the old pump pack prior to removing it from the motor.
- The replacement pump pack shipped from HySecurity is wrapped in plastic and mounted on a board. If the replacement is under warranty, use the shipping materials to wrap the old pump pack and ship it per the RMA instructions. Damage incurred during shipping may be grounds for refusal of an RMA.

NOTE: All replacement pump packs are shipped without solenoid coils. Be sure to transfer the coils from the original to the replacement pump pack.



To avoid risk of injury or death, disconnect the gate operator from the main power source prior to performing any of the following service procedures!

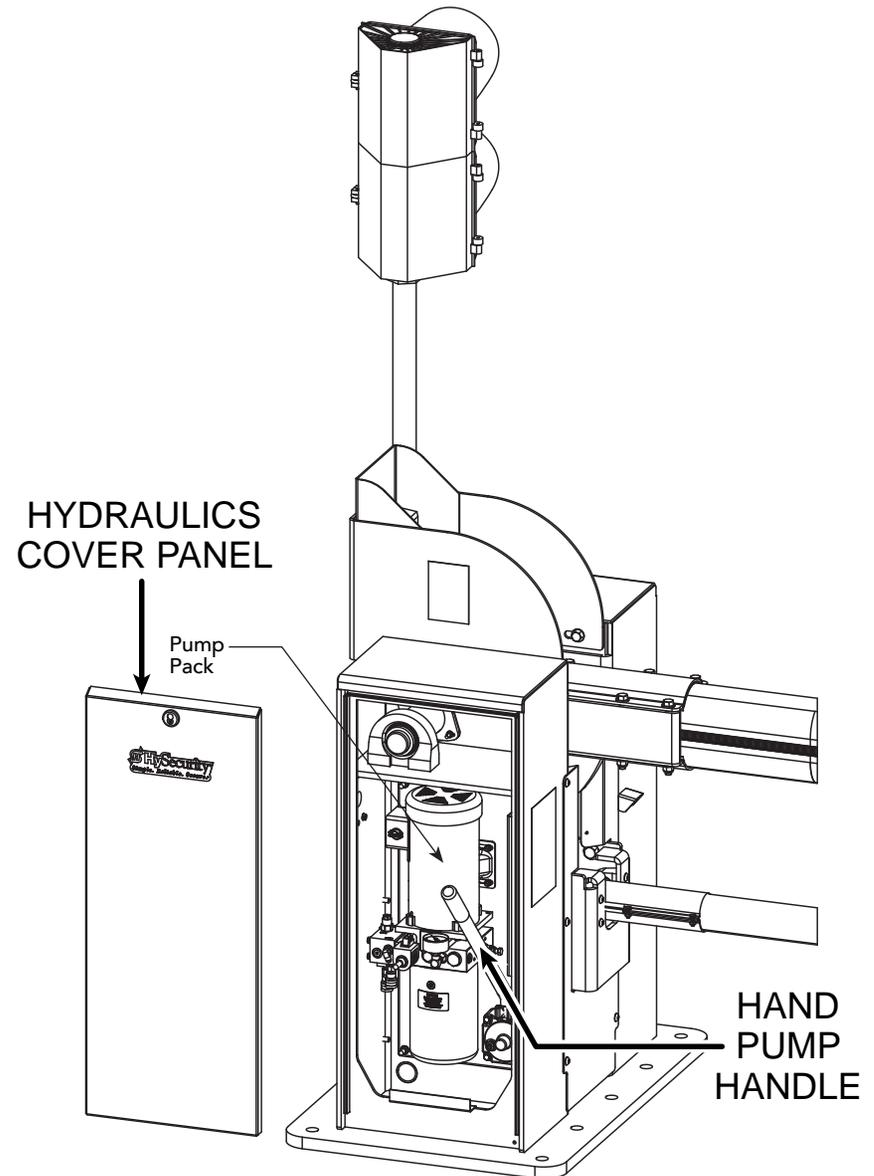

StrongArmCrash M30/M50 Chassis Interior

Hydraulic Pump Pack Removal

NOTE: All pump packs are shipped with couplings and pre-lubed pump shafts. Do NOT remove the red dust cover until the new coupling is installed on the electric motor and you are ready to attach the pump.

To remove the existing pump pack, take the following steps:

1. Access the motor and pump pack in the pivot post chassis. Make sure the power disconnect switch is in the OFF position. See illustration on page 1.
2. Turn OFF power to the operator at the main disconnect.
3. Check to see if the pump pack you received from HySecurity is the same as the unit you are replacing. Verify that both the old and replacement pump packs match.

4. Remove the $\frac{3}{4}$ inch hex nut which secures the solenoid coil onto its valve stem.
5. Slide the coil off the open valve.

NOTE: The solenoid coil and the cable will be reused! Use care when removing them since any damage incurred is not covered by the Limited Warranty.

6. To keep the hydraulic fluid contained in the pump pack, remove the breather cap and insert a vent plug. If you don't have an extra vent plug, unscrew the vent plug from the new replacement pump pack and use it.
7. If a hand pump is connected, unscrew the shipping cap from the hand pump output hose connection on the replacement pump pack. Use it to replace the hose connection at the base of the pump pack. During this transfer process, about $\frac{1}{4}$ cup of fluid will leak out from the base of the motor/pump pack assembly. Have rags handy to absorb any fluid residue.

8. Disconnect the remaining hoses.

NOTE: If your machine does not have quick disconnects (QD's), unscrew the hose fittings from the pump. Keep the hose ends supported above the hydraulic cylinders, otherwise the hydraulic fluid will drain out.

9. Use a 7/16-inch socket wrench to remove the electric motor and pump pack assembly from the panel mounts.

Mark and disconnect the electrical wires inside the Motor Junction Box before removing the motor/pump pack assembly from its bracket.

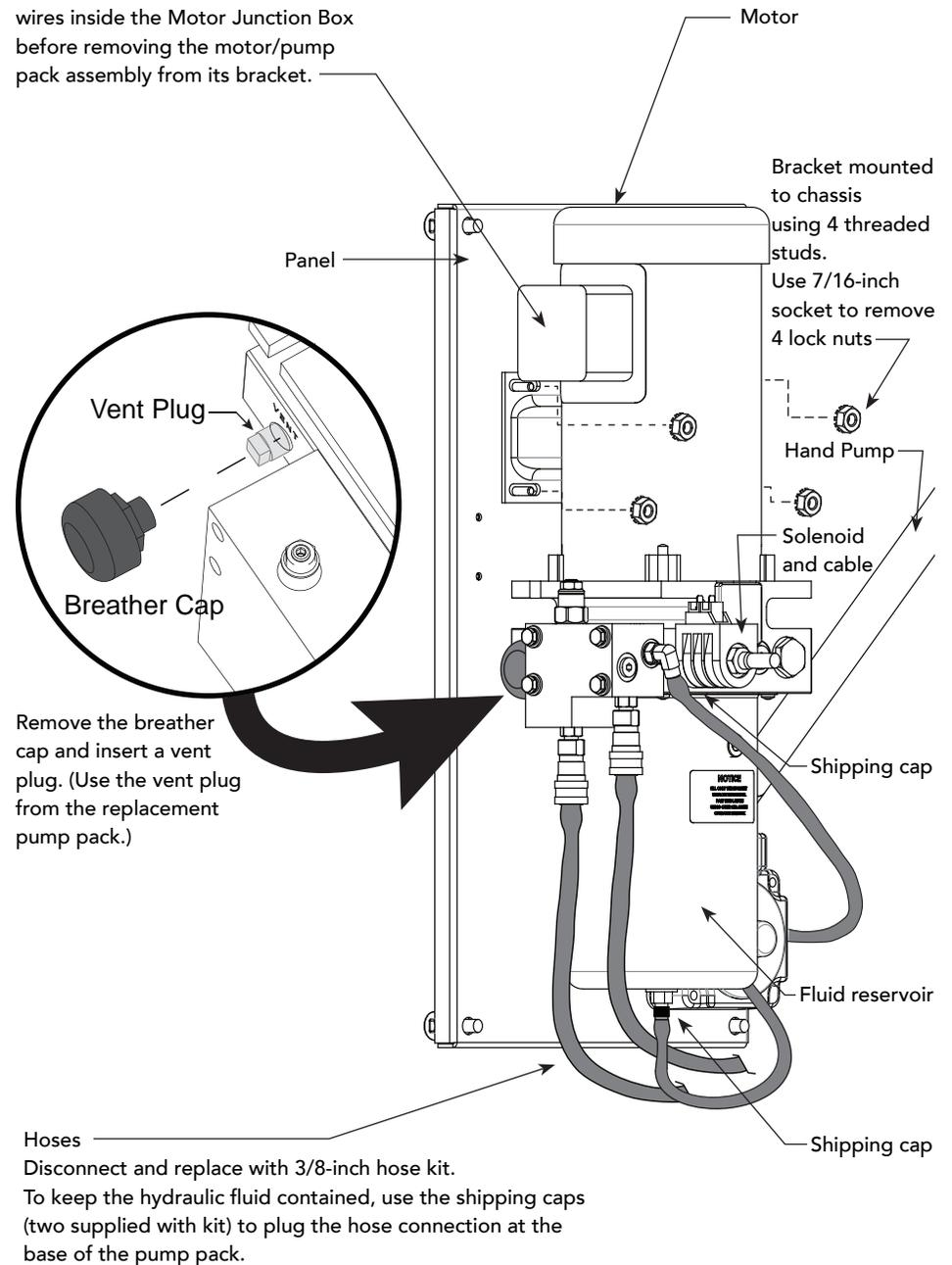

- Separate the pump pack from the electric motor by removing the two mounting bolts using a 9/16 inch wrench. The bolts are factory-installed with blue thread lock (Loctite® 545), so it will require a bit of torque to remove them. Gently, rock the pump pack to disengage the coupling and to pull the motor and pump pack apart.



Do not use a pry bar or a screwdriver to separate the pump pack from the electric motor as damage may occur to the motor's shaft.

- Remove the motor coupling by loosening the set screw. Slide the coupling and the metal key off the motor's shaft.
- Discard the coupling and metal key. A new coupling and metal key are supplied with the replacement pump pack.

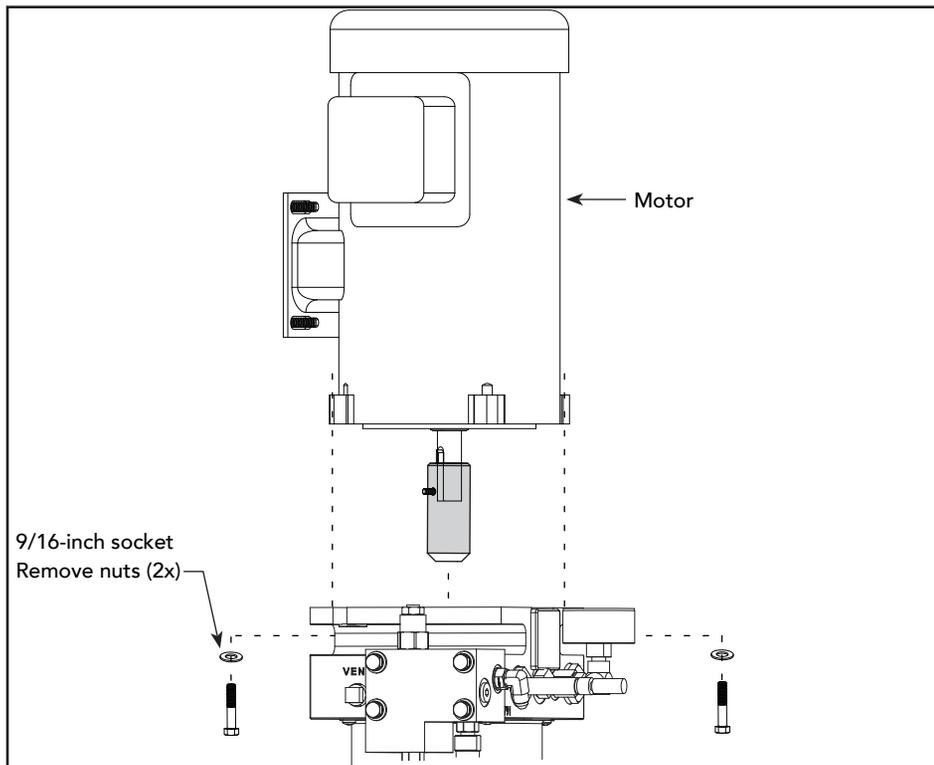

Hydraulic Pump Pack Replacement

To replace the existing pump pack, take the following steps:

- Prepare the replacement pump pack by removing any accessories (such as the breather cap) that may be tie-wrapped to the pump pack kit.
- Locate the motor coupling shipped with the replacement pump pack.
- Loosen the set screw on the coupling.
- Place the metal shaft key securely in the motor's shaft.
- Align the coupling with the metal shaft key and slide the coupling onto the motor's shaft as far as it will go. Tap the coupling lightly with a plastic or rubber mallet to be sure it is situated completely on the motor's shaft.
- Place blue-colored Loctite® onto the coupling set screw and tighten it securely.
- Remove the red dust cover from the pump pack's manifold.

NOTE: Review the illustration on the next page for all component parts of the pump pack assembly.

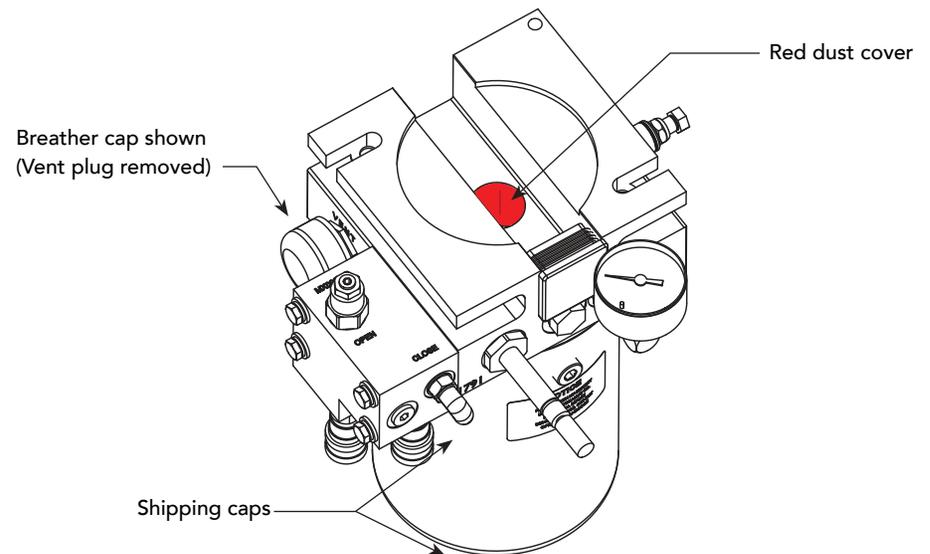

8. Look inside the shaft to verify that the pump shaft is coated with "anti-seize" (grease). If grease has not been applied, call Technical Support.
9. Coat the end of both mounting bolts with blue-colored Loctite®.
10. Orient the pump pack assembly as shown in the illustration.
11. Carefully, lift the pump pack onto the motor's shaft. Make sure the sleeves in the coupling interlock with the teeth on the pump's shaft. Continue until the pump pack and the base of the motor are touching.
12. Insert both bolts and alternately tighten each bolt so there is even closure between the motor and pump pack. No torque setting is required, but make sure to tighten the bolts securely.
13. Make sure the vent plug and shipping cap are securely in place, and then remove the base plug and connect the hand pump hose. Remove the shipping caps and reconnect its hose to the hand pump.
14. Reconnect the remaining hydraulic hoses. Replace 1/4-inch hoses with the 3/8-inch hoses.

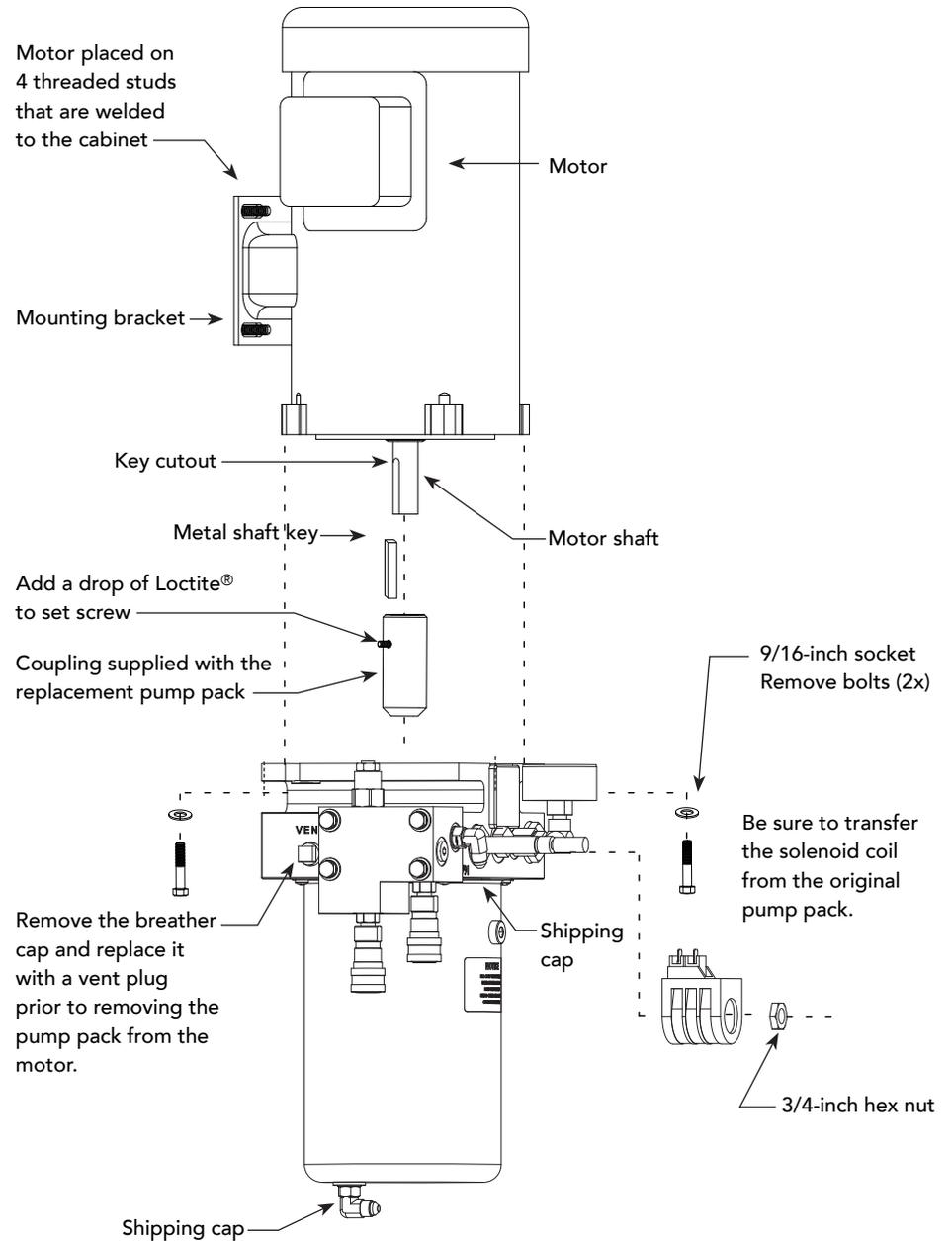

Finishing the Installation

To complete the installation:

1. Remove the vent plug from the replacement pump pack. And install the breather cap (shipped tie-wrapped to the replacement pump pack) onto the replacement pump pack.

CAUTION

If the breather cap is not properly installed, pump pack seals may be damaged and you may void the Limited Warranty.

2. Before packaging and shipping the old pump pack, make sure the vent plug and shipping cap are securely in place. Refer to the illustration on page 4 to identify the location of both.
3. Replace the solenoid coil. Re-attach the solenoid coil to the open valve and lightly tighten the nut.

CAUTION

Do not over-tighten the 3/4 inch nut that holds the coil in place. A damaged or bent solenoid valve will not work properly and is not covered by the Limited Warranty.

4. Reconnect any wiring disconnected during the removal of the pump pack.
5. Perform any model-specific instructions pertinent to your operator. Refer to the installation manual.
6. Turn ON the main power to the operator.
7. Turn ON the directional power switch inside the Pivot Post.
8. If necessary, adjust the brake valve. Refer to the *Programming and Operations Manual*.
9. Prevent rust or corrosion by touching-up any damage to the paint on the cabinet.

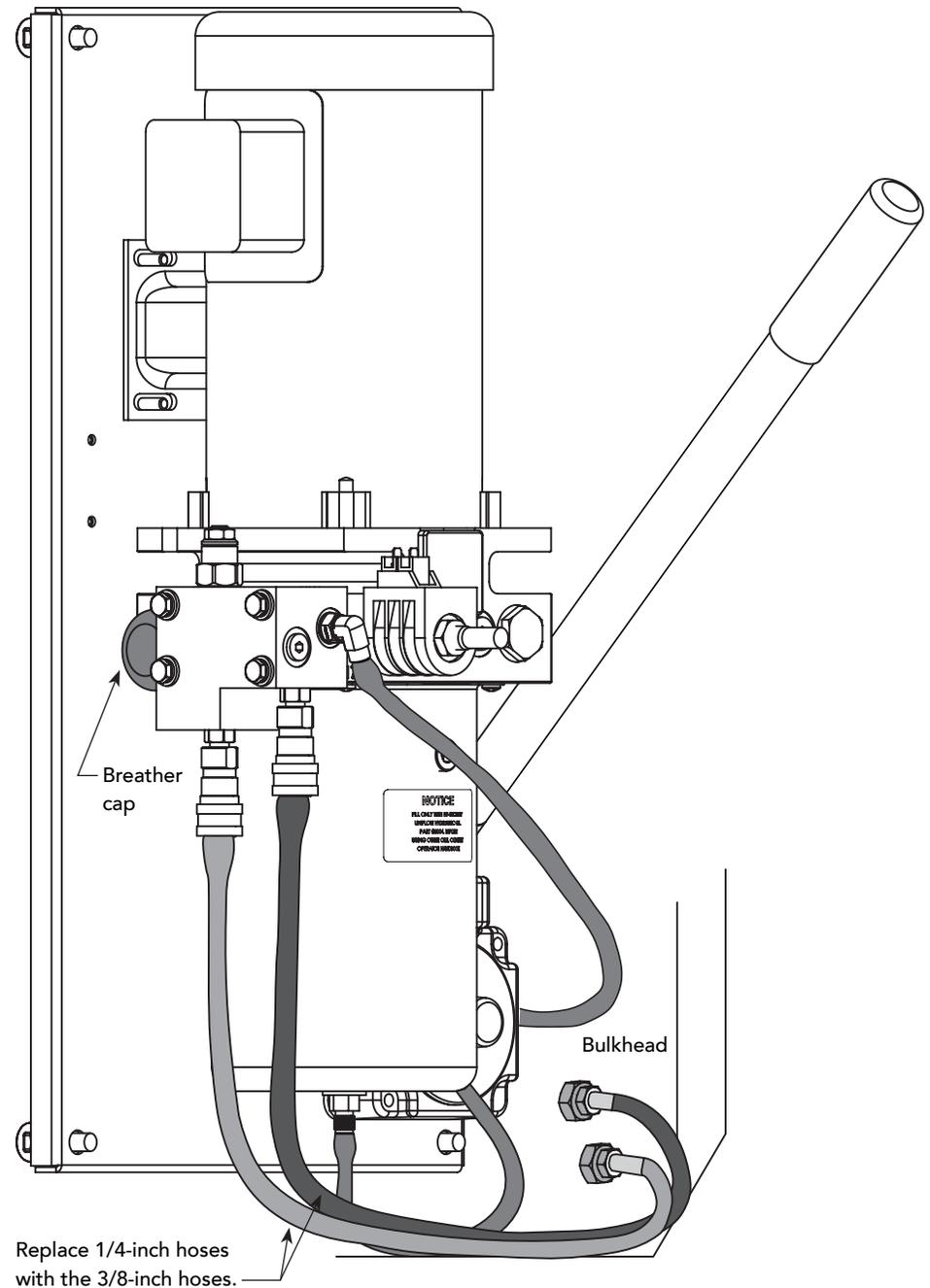



Maintenance

For maintenance or troubleshooting issues, refer to the operator's product manual. If you do not have a copy of the manual, it is available on the HySecurity website at www.hysecurity.com.

Technical Support

For Technical Support, call your installer or authorized HySecurity distributor. Obtain the serial number of your operator before calling. For the name of a distributor near you, call HySecurity at 800-321-9947 or refer to the company website at www.hysecurity.com.