

StrongArmPark DC Replacement Belt

Tools Required

- Utility knife
 - 6 mm hex key
 - Paper towels or clean rags to clean up oil spills
1. Remove fill hole cap
 2. Turn off the AC and DC power switches.
 3. Remove the StrongArmPark DC top cover.
 4. Use a phillips head screwdriver to remove two screws that secure the drive belt cover. Set the drive belt cover and fasteners aside.
 5. To remove the 9 mm drive belt, loosen the four motor mount bolts, using a 9/16-inch box end or ratchet wrench. Slide the motor to relieve tension and remove the belt and discard it.

Replace the Small Pulley

1. Two set screws hold the small motor pulley in place. Use a 2.5 mm hex key to remove the set screws and discard the small pulley.
2. Replace the pulley with the one from the kit. Set the pulley on the shaft so the top of it is flush with the top of the gear box pulley. Secure the pulley with the set screws.

NOTE: Use a straightedge along the top of the pulleys to verify flush mounting. The new pulley is positioned higher on the shaft than the one it replaced.

3. Install the 15 mm belt and re-tension it by sliding the motor bracket. See illustration.

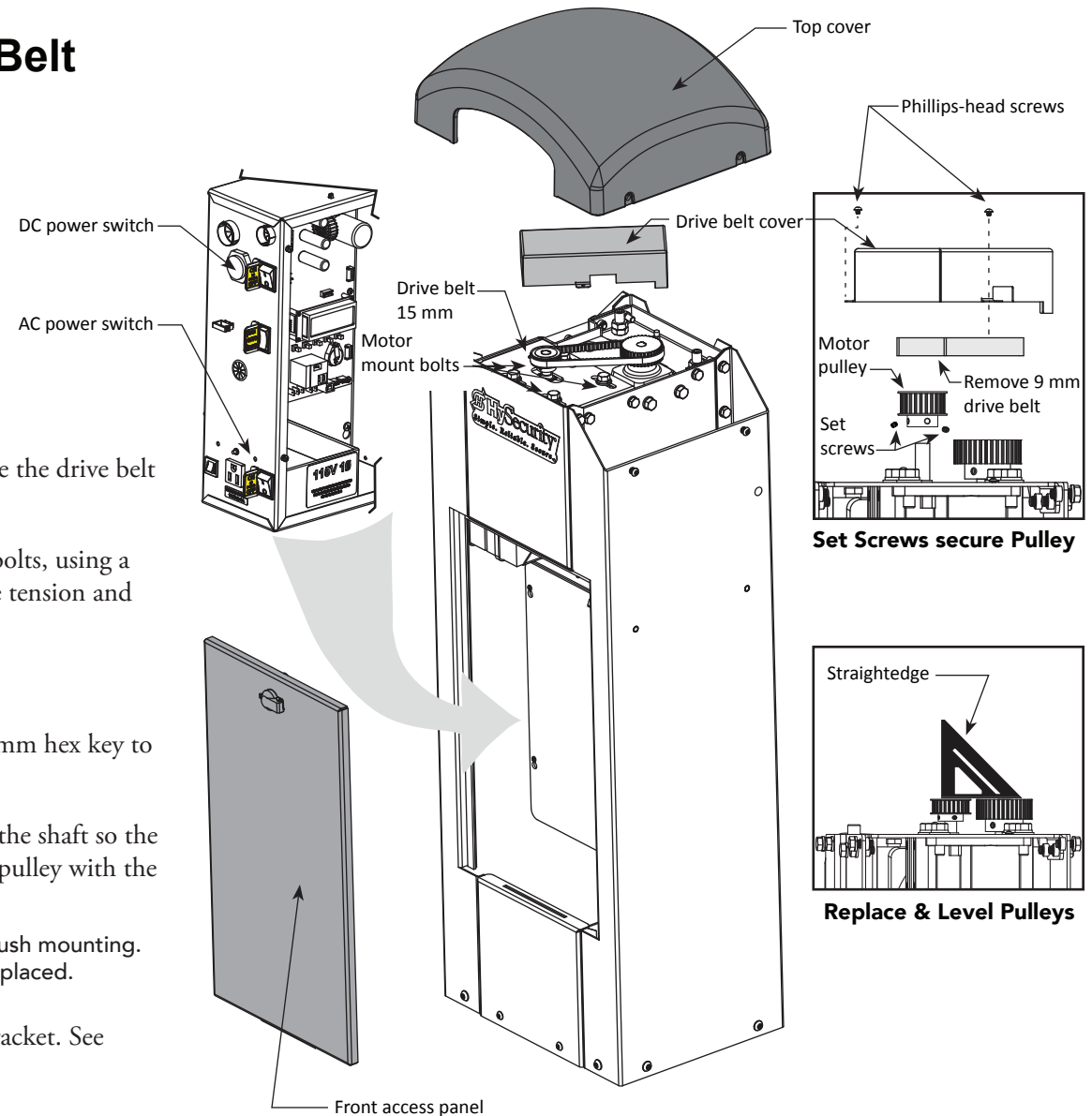

4. Retighten the motor mount bolts when the belt is positioned properly.

NOTE: With you finger, apply light pressure to the drive belt. If it is properly tensioned, it should only move about 1/16 to 1/8-inch.
5. Replace the drive belt cover and top cover. Refer to the first page illustration.
6. Turn the AC and DC switches ON. This cycles the power which allows the operator to search for the target magnet and “relearn” it limits.

NOTE: Be aware that the arm will cycle open, and then close, as it relearns its limits. If you don’t cycle the power, the operator will not “relearn” its limits and will not operate properly.

Technical Support

For technical support, call your installer or authorized HySecurity distributor. Obtain the serial number of your operator before calling. For the name of a distributor near you, call HySecurity at 800-321-9947.

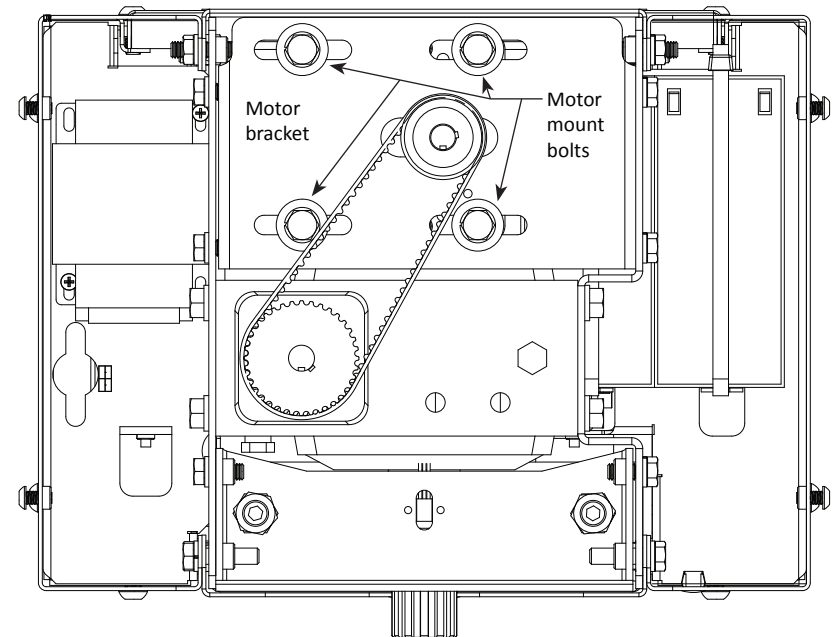
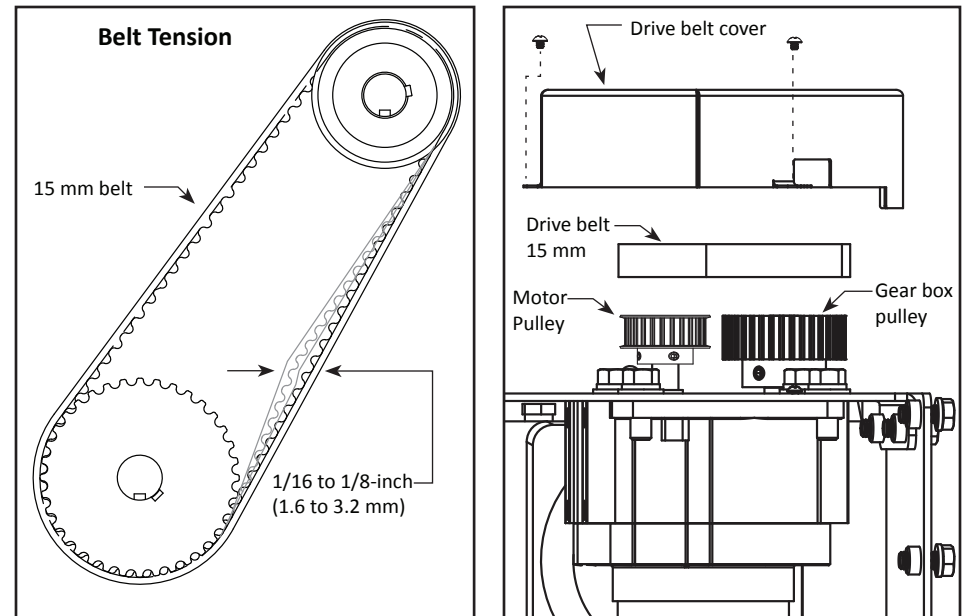

Overhead View