

# Nice Apollo Slide Gate Opener

Vehicular Slide Gate Opener

8300 SL - 1/2 HP

8500 SL - 1 HP



Nice



# TABLE OF CONTENTS

<b>1 - OVERVIEW</b>	2	<b>21 - INSPECTION AND OPERATION</b>	25
<b>2 - GENERAL SAFETY INFORMATION</b>	4	<b>22 - GENERAL LAYOUT AND SAFETY ACCESS</b>	26
<b>3 - USE OF VEHICLE DETECTORS</b>	7	<b>23 - ACCESSORIES AND SENSORS</b>	27
<b>4 - GATE CONSTRUCTION AND SAFETY</b>	7	23.1 - Monitored Safety Device Types	27
<b>5 - MAINTENANCE OF GATE SYSTEMS</b>	9	<b>24 - IRB-RET WIRING DIAGRAM</b>	28
<b>6 - ENTRAPMENT PROTECTION</b>	10	<b>25 - GEM-103 WIRING DIAGRAM</b>	29
<b>7 - COMPATIBLE EXTERNAL SENSORS</b>	11	<b>26 - WEL-200 WIRING DIAGRAM</b>	29
<b>8 - SLIDE OPERATOR CUTAWAY DRAWINGS</b>	12	<b>27 - BOARD NOMENCLATURE</b>	30
8.1 - Slide operator cutaway drawings-cont.	12	<b>28 - PROGRAMMING QUICKSTART</b>	31
<b>9 - INSTALLATION PROCEDURES</b>	13	28.1 - Learning the gate	31
9.1 - Step one-location	13	28.2 - Gate direction reversal	31
9.2 - Step two-concrete	13	28.3 - Putting the controller into learning mode	31
9.3 - Step three-physical mounting	13	<b>29 - PROGRAMMING BUTTONS</b>	31
9.4 - Step four-manual release	13	29.1 - Force	31
9.5 - Step five-chain assembly	13	29.2 - Speed	31
9.6 - Learning and programming	14	29.3 - Acceleration	31
9.7 - How to setup for first use	14	29.4 - Delay	31
9.8 - The learning sequence	15	29.5 - Function	32
9.9 - Learning mode	15	29.6 - Display	33
<b>10 - GATE DIRECTION REVERSAL</b>	15	<b>30 - EMERGENCY VEHICLE ACCESS</b>	34
<b>11 - POWER INPUTS ON BOARD</b>	15	<b>31 - GLOSSARY</b>	34
<b>12 - RE-ASSEMBLING GATE OPERATOR</b>	16	<b>32 - MAINTENANCE SCHEDULE - NICE GATE OPENER</b>	35
<b>13 - CIRCUIT BOARD LAYOUT</b>	17	<b>33 - NICE GATE OPENER TROUBLESHOOTING</b>	35
<b>14 - 8300/8500 WIRING</b>	17	<b>34 - WARRANTY</b>	37
<b>15 - SETTING THE LIMIT SWITCHES</b>	18	<b>35 - INSTALLATION CHECKLIST</b>	38
<b>16 - LEARNING MODE</b>	19		
<b>17 - ACCESSORY INPUTS AND OUTPUTS</b>	20		
17.1 - Outputs	20		
17.2 - Inputs	20		
17.3 - Communication bus	20		
17.4 - Programming the plug-in receiver and remote controls	21		
<b>18 - 120VAC WIRING AND CONNECTIONS</b>	22		
<b>19 - SOLAR PANEL CHART</b>	22		
<b>20 - OPTIONAL INPUTS</b>	23		
20.1 - Fire input	23		
20.2 - Fail safe connection	23		
20.3 - Magnetic lock connection	23		
20.4 - Guard station connection	23		
20.5 - Exit and edge inputs wiring diagram	24		
20.6 - Radio receiver connection (third party)	24		
20.7 - Optional power output	24		

## 1. Overview

Congratulations on selecting a Nice gate operator for automating your gate system. With proper selection, system design, installation and maintenance this operator should provide years of reliable operation.

This manual covers the following Nice operator models: 8300 and 8500.

### 1.1 1050 Control Board

The 1050 main control board is housed in a protective plastic enclosure that includes a 2-line LCD, with 5 dedicated buttons and 3 buttons for navigation of the setup, programming, and information menus, as well as 3 buttons for open, close, and stop. Connectors for power, inputs, and output peripherals are arranged around the edges of the board and clearly labeled. A plug-in connector is provided for direct installation of a Nice-brand receiver which can be controlled by up to 1000 transmitters. A recessed RJ-11 jack offers a connection to an optional O-View programmer and optional Bluetooth module that can be programmed via PC. Connectors for other Nice-brand plug in accessories include 2-wire Bluebus, self-monitored photocells for entrapment protection. Dry contact inputs are provided for loop, probe, and photoelectric detectors, as well as guard station and fire department control of gate opening and closing. Voltage outputs (+12VDC and +24VDC) are also made available to power safety and entrapment-prevention devices, and a magnetic lock if required. On board charge control circuitry delivers reliable power to a backup battery (if installed) and the unit is equipped with input for a solar panel for self-powered installations.

The 1050 main control board accepts DC input voltage ranging from 10VDC to 32VDC. A 2-line LCD with dedicated buttons allows installer to quickly program the 1050 when changes to its factory-default settings need to be made. A real time clock/calendar enables programming for scheduled weekly or daily events like opening, closing, or locking the gate. Gate opening and closing speed, acceleration, soft-start settings, and reversing speed may be set to factory

default settings, or individually programmed per customized gate installation requirements. Built-in current sensing enables inherent gate force monitoring and limiting for safety and an on board alarm indicates when two sequential obstructions have been sensed in either direction. The "Learn" function helps gate installer configure Nice 1050 control board semi-automatically for optimum settings of gate opening and closing speeds, with simple programmable adjustments to force and speed settings that may be made with the programming button on the control panel.

### 1.2 1050 Control Board Features

- Inputs for solar panel, batteries, and Main DC Power.
- Low power consumption in stand-by mode.
- Built-in regulator to keep battery charged (either through solar or main DC power).
- Socket for plug-in Nice receiver.
- Board compatible with Nice Opera System (facilitates programming and diagnostic's away from the site of installation). Requires optional O-View and OVBT (Bluetooth) module.
- Easy programming with LCD display and dedicated buttons.
- Digital programming for auto-close, force, speed, opening delay.
- On board buttons for operating the gate (Open, Close, Stop).
- Built-in voltmeter to check input voltage, battery voltage, solar panel voltage, motors' current.
- Temperature sensor to optimize charging battery and system performance.
- Programmable service alarm.
- 2 Programmable timers (from 1 sec to 9 hours).
- Inputs for guard station, additional third party receivers, loop detectors, FIRE and UL/Edge signals.
- 2 programmable inputs (open, close, step, mid-position, hold to open, hold to close, activating timer).
- Surge suppression on every peripheral input (digital and analog).
- Ports for self-powered Nice plug-in peripherals. (BlueBus).

### 1.3 What is Included

<b>P/N</b>	<b>Name</b>	<b>QTY</b>
8300/8500	8300/8500	1
#10020715	Chain Bracket	2
#10025215	#40 Chain	35 feet
#10016790	Hardware Kit	1

### 1.4 Product Specifications

<b>Model</b>	<b>8300SL</b>	<b>8500SL</b>
Duty Cycle	Varies based on charger type	
Drive	Electromechanical	
Gate Length Max.	1 ft/sec (30 cm/s)	
Gate Weight Max	1,000 lb (454 kg)	1,500 lb (680 kg)
Temperature Rating	-4° to 150° F (-20° to 65° C)	
Operating Voltage	24VDC	
Input Voltage	10 - 32VDC	
Idle Current	110mA (Awake) / 10mA (Standby)	
Accessory Power	12VDC and 24VDC 1A each	
User Controls	1050 board	
Relays	2 programmable relays	
Listed to UL325	Usage Class I, II, III, IV	

1.5 The installation of this product is not a “do-it-yourself” project. A qualified gate operator installation company should be contacted to install the gate operator to ensure a safe and reliable installation. Since many aspects of gate system installation are under the control of the installer, it is the responsibility of the property owner to ensure the installer is qualified to carry out the installation in a safe and professional manner.

1.6 Consult local government agencies for up-to-date rules and regulations as certain municipalities have established licensing, codes or regulations that regulate automated gate system design and installation.

## 2. General Safety Information

A gate operator is only a component in a gate system. The other parts of the gate system can include the gate, the external entrapment sensors, access controls, and vehicle detectors. To have a gate system that provides safety, security, and reliable operation it is essential these components operate together as a system. It is the responsibility of the system designer and/or installer to ensure any safety or operational issues have been addressed.

### IMPORTANT SAFETY INSTRUCTIONS



#### WARNING

To reduce the risk of injury or death.

1. READ AND FOLLOW ALL INSTRUCTIONS.
2. Never let children operate or play with gate controls. Keep the remote control away from children.
3. Always keep people and objects away from the gate. NO ONE SHOULD CROSS THE PATH OF THE MOVING GATE.
4. Test the gate operator monthly. The gate MUST reverse on contact with a rigid object or stop when an object activates the non-contact sensors. After adjusting the force or the limit of travel, retest the gate operator. Failure to adjust and retest the gate operator properly can increase the risk of injury or death.
5. Use the emergency release only when the gate is not moving.
6. KEEP GATES PROPERLY MAINTAINED. Read the user’s manual. Have a qualified service person make repairs to gate hardware.
7. The entrance is for vehicles only. Pedestrians must use separate entrance.
8. SAVE THESE INSTRUCTIONS.

## 2.1 UL325 Usage Classes

The UL325 standard covers gate operators. Within this safety standard several Usage Classes are described that define different types of installations where gate operators can be applied. Some operators are restricted in their usage application. All Nice USA operators are approved for use in all four UL325 Usage Classes. Appropriate Usage Classes are shown in the Specifications.

2.1.1 Class I Residential Gate Operator. Intended for use in a location of one to four single family dwellings or a parking area associated with one to four single family dwellings.



2.1.2 Class II Commercial / General Access Gate Operator. Intended for use in a commercial location or building such as a multi-family housing units (five or more single family units) hotels, garages, retail stores or other buildings servicing general public.



2.1.3 Class III Industrial / Limited Access Gate Operator. Intended for use in an industrial location or building such as factories or loading docks or other locations not intended to service general public.

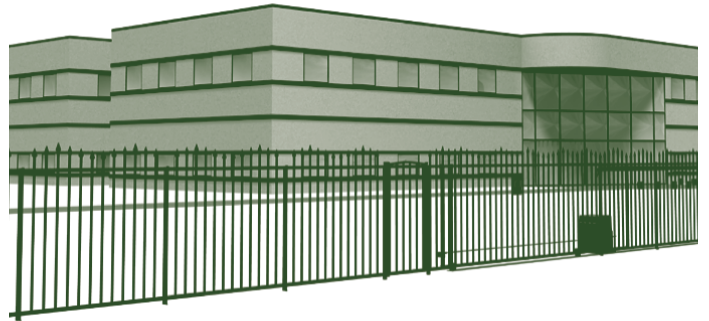

2.1.4 Class IV Restricted Access Gate Operator. Intended for use in guarded industrial locations or buildings such as an airport security area or other restricted access location, not servicing general public, in which access is monitored by security personnel or via closed circuitry.



## 2.2 Vehicular Traffic Only

This automatic gate operator is not designed nor is it intended for pedestrian traffic. Vehicular gate operators must by their nature be powerful to function reliably. This power can cause injury or death. Accordingly, direct all pedestrian traffic to a separate walk-through gate.

### 2.3 Install This Gate Operator Only When:

- a. The operator is appropriate for the construction of the gate and the usage Class of the gate,
- b. All openings of a horizontal slide gate are guarded or screened from the bottom of the gate to a minimum of 1.83 m (6 ft) above the ground to prevent a 57.2 mm (2-1/4 inch) diameter sphere from passing through the openings anywhere in the gate, and the portion of the adjacent fence that the gate covers in the open position,
- c. All exposed pinch points are eliminated or guarded, and
- d. Guarding is supplied for exposed rollers.

2.4 The operator is intended for installation only on gates used for vehicles. Pedestrians must be supplied with a separate access opening. The pedestrian access opening shall be designed to promote pedestrian usage. Locate the gate such that persons will not come in contact with the vehicular gate during the entire path of travel of the vehicular gate.

2.5 The gate must be installed in a location so that enough clearance is supplied between the gate and adjacent structures when opening and closing to reduce entrapment risk. Swinging gates shall not open into public access areas

2.6 The gate must be properly installed and work freely in both directions prior to gate operator installation. Do not over-tighten the operator clutch or pressure relief valve to compensate for an improperly installed, improperly functioning, or damaged gate.

2.7 Permanently mounted controls intended for user activation must be located at least 1.83 m (6 ft) away from any moving part of the gate and where the user is prevented from reaching over, under, around or through the gate to operate the controls. Exception: Emergency access controls only accessible by authorized personnel (e.g. fire, police, EMS) may be placed at any location in the line-of-sight of the gate.

2.8 The Stop and/or Reset button must be located in the line-of-sight of the gate. Activation of the reset control shall not cause the operator to start.

2.9 A minimum of two (2) WARNING SIGNS shall be installed, in the area of the gate. Each placard is to be visible by persons located on the side of the gate on which the placard is installed.

2.10 When utilizing a Nice board, a maximum of 8 entrapment protection devices may be connected.

2.11 For gate operators utilizing a non-contact sensor (Photo Eye):

- a. See instructions on the placement of non-contact sensors for each Type of application,
- b. Care shall be exercised to reduce the risk of nuisance tripping, such as when a vehicle, trips the sensor while the gate is still moving, and
- c. One or more non-contact sensors shall be located where the risk of entrapment or obstruction exists, such as the perimeter reachable by a moving gate or barrier.



2.12 For a gate operator utilizing a contact sensor (Edge):

- a. One or more contact sensors shall be located where the risk of entrapment or obstruction exists, such as at the leading edge, trailing edge, and postmounted both inside and outside of a vehicular horizontal slide gate.
- b. A hardwired contact sensor shall be located and its wiring arranged so that the communication between the sensor and the gate operator is not subjected to mechanical damage.
- c. A wireless device such as one that transmits radio frequency (RF) signals to the gate operator for entrapment protection functions shall be located where the transmission of the signals are not obstructed or impeded by building structures, natural landscaping or similar obstruction. A wireless device shall function under the intended end-use conditions.
- d. One or more contact sensors shall be located on the inside and outside leading edge of a swing gate. Additionally, if the bottom edge of a swing gate is greater than 152 mm (6 in) but less than 406 mm (16 in) above the ground at any point in its arc of travel, one or more contact sensors shall be located on the bottom edge.

### 3. Use of Vehicle Detectors

Use of vehicle detectors (loop detectors) is strongly encouraged to prevent damage to vehicles caused by gates closing on them. This is not considered to be a safety item as vehicle detectors cannot provide protection to pedestrians. In some situations, photoelectric devices may be used as vehicle detectors, but should be wired accordingly.

## 4. Gate Construction and Safety

Gate construction plays a very important role in ensuring the safety of any automated gate system. The standard for gate construction is ASTM F2200. Below are key areas to address safety in gate design. For complete information consult the standard. Copies of the standard are available at:

<https://www.astm.org/Standards/F2200.htm>

Another source of information is available from DASMA, the Door and Access System Manufacturer's Association. The Association publishes Technical Data Sheets, one of which concerns ASTM F2200. For more information, see:

<http://www.dasma.com/PDF/Publications/TechDataSheets/OperatorElectronics/TDS370.pdf>

### 4.1 General Requirements for gate construction

- 4.1.1 Gates shall be constructed in accordance with the provisions given for the appropriate gate type listed. Refer to ASTM F2200 for additional gate types.
- 4.1.2 Gates shall be designed, constructed and installed to not fall over more than 45 degrees from the vertical plane, when a gate is detached from the supporting hardware.
- 4.1.3 Gates shall have smooth bottom edges, with vertical bottom edged protrusions not exceeding 0.50 in. (12.7 mm) when other than the Exceptions listed ASTM F2200.
- 4.1.4 The minimum height for barbed wire shall not be less than 6 ft. (1.83 m) above grade. The minimum height for barbed tape shall not be less than 8 ft. (2.44 m) above grade.
- 4.1.5 An existing gate latch shall be disabled when a manually operated gate is retrofitted
- 4.1.6 A gate latch shall not be installed on an automatically operated gate.
- 4.1.7 Protrusions shall not be permitted on any gate. Consult ASTM F2200 for exceptions.

4.1.8 Gates shall be designed, constructed and installed such that their movement shall not be initiated by gravity when an automatic operator is disconnected.

4.1.9 For pedestrian access in the vicinity of an automated vehicular gate, a separate pedestrian gate shall be provided. The pedestrian gate shall be installed in a location such that a pedestrian shall not come in contact with a moving vehicular access gate. A pedestrian gate shall not be incorporated into an automated vehicular gate panel.

4.1.10 Any non-automated gate that is to be automated shall be upgraded to conform to the provisions of this specification.

4.1.11 This specification shall not apply to gates generally used for pedestrian access and to vehicular gates not to be automated.

4.1.12 Any existing automated gate, when the operator requires replacement, shall be upgraded to conform to the provisions of this specification in effect at that time.

## 4.2 Vehicular Horizontal Slide Gate Requirements

4.2.1 The following provisions shall apply to Class I, Class II and Class III vehicular horizontal slide gates:

4.2.1.1 All weight bearing exposed rollers 8 ft (2.44 m), or less, above grade shall be guarded or covered

4.2.1.2 All openings shall be designed, guarded, or screened from the bottom of the gate to the top of the gate or a minimum of 72 in. (1.83 m) above grade, whichever is less, to prevent a 2 1/4 in. (57 mm) diameter sphere from passing through the openings anywhere in the gate, and in that portion of the adjacent fence that the gate covers in the open position. The gate panel shall include the entire section of the moving gate, including any back frame or counterbalance portion of the gate.

4.2.1.3 A gap, measured in the horizontal plane parallel to the roadway, between a fixed stationary object nearest the roadway (such as a gate support post) and the gate frame when the gate is in either the fully open position or the fully closed position, shall not exceed 2 1/4 in. (57 mm). Exception: All other fixed stationary objects greater than 16 in. (406 mm) from the gate frame shall not be required to comply with this section.

4.2.1.4 Positive stops shall be required to limit travel to the designed fully open and fully closed positions. These stops shall be installed at either the top of the gate, or at the bottom of the gate where such stops shall horizontally or vertically project no more than is required to perform their intended function.

4.2.1.5 All gates shall be designed with sufficient lateral stability to assure that the gate will enter a receiver guide. Consult ASTM F2200 for details on various gate panel types.

4.2.2 The following provisions shall apply to Class IV vehicular horizontal slide gates:

4.2.2.1 All weight bearing exposed rollers 8 ft (2.44 m), or less, above grade shall be guarded or covered.

4.2.2.2 Positive stops shall be required to limit travel to the designed fully open and fully closed positions. These stops shall be installed at either the top of the gate, or at the bottom of the gate where such stops shall horizontally or vertically project no more than is required to perform their intended function.

### 4.3 Vehicular Horizontal Swing Gates

- 4.3.1 The following provisions shall apply to Class I, Class II, and Class III horizontal swing gates:
- 4.3.2 Gates shall be designed, constructed and installed so as not to create an entrapment area between the gate and the supporting structure or other fixed object when the gate moves toward the fully open position, subject to the following provisions.
- 4.3.3 The width of an object (such as a wall, pillar or column) covered by a swing gate when in the open position shall not exceed 4 in. (102 mm), measured from the centerline of the pivot point of the gate. Exception: For a gate that is not in compliance with this provision, the defined area shall be subject to the entrapment protection provisions of UL 325.
- 4.3.4 Except for the zone specified in 3.3.3 the distance between a fixed object such as a wall, pillar or column, and a swing gate when in the open position shall not be less than 16 in. (406 mm). Exception: For a gate that is not in compliance with this provision, the defined area shall be subject to the entrapment protection provisions of UL 325.
- 4.3.5 Class IV vehicular horizontal swing gates shall be designed, constructed and installed in accordance with security related parameters specific to the application in question.

### 5. Maintenance of Gate Systems

To keep your automated gate system performing both safely and reliably it is important to ensure that the components of that system are functioning properly. At least monthly:

- 5.1 Disconnect the gate operator and manually move the gate through its range of travel. Note any squeaks from rollers or hinges or areas of binding. The gate should travel smoothly and quietly throughout its range. If it does not, contact a gate professional to correct the problem.
- 5.2 Reconnect the gate operator and perform the following tests:
  - 5.2.1 With the gate opening, block any photo eyes and/or depress any safety edges used to protect the open direction. The gate should stop, or, stop and reverse.
  - 5.2.2 With the gate closing, block any photo eyes and/or depress any safety edges used to protect the close direction. The gate should stop, or, stop and reverse.
  - 5.2.3 Using a suitable obstruction in the path of the gate (a solid, immovable object), run the gate in the open direction until it contacts the obstruction. The gate should stop and reverse.
  - 5.2.4 Using a suitable obstruction in the path of the gate (a solid, immovable object), run the gate in the close direction until it contacts the obstruction. The gate should stop, or, stop and reverse.

## 6. Entrapment Protection

The UL325 standard for gate operators requires a minimum of two independent entrapment protection means for each entrapment zone. An entrapment zone is defined as follows:

For slide gates, any locations between a moving gate and a counter opposing edge or surface where entrapment is possible up to a height of 6 ft. (1.83m) above grade. Such locations occur if at any point in travel the gap between a moving gate and the fixed counter opposing edges or surfaces is less than 16 in. (406mm).

For swing gates, locations between a moving gate or moving, exposed operator components and a counter opposing edge or surface where entrapment is possible up to 6 ft (1.83m) above grade. Such locations occur if during any point in travel:

- The gap between the bottom of a moving gate and the ground is greater than 4 in. (101.6 mm) and less than 16 in. (406 mm); or
- The distance between the center line of the pivot and the end of the wall, pillar, or column to which it is mounted when in the open or closed position exceeds 4 in. (101.6 mm). Any other gap between a moving gate and fixed counter opposing edges or surfaces or other fixed objects is less than 16 in. (406 mm) (examples are walls, curbs, berms or other immovable objects).

Potential entrapment zones are shown in image below for slide and swing gates, but keep in mind there may be other entrapment zones presented by the actual installation and adjacent structures or landscape that must be protected as well.

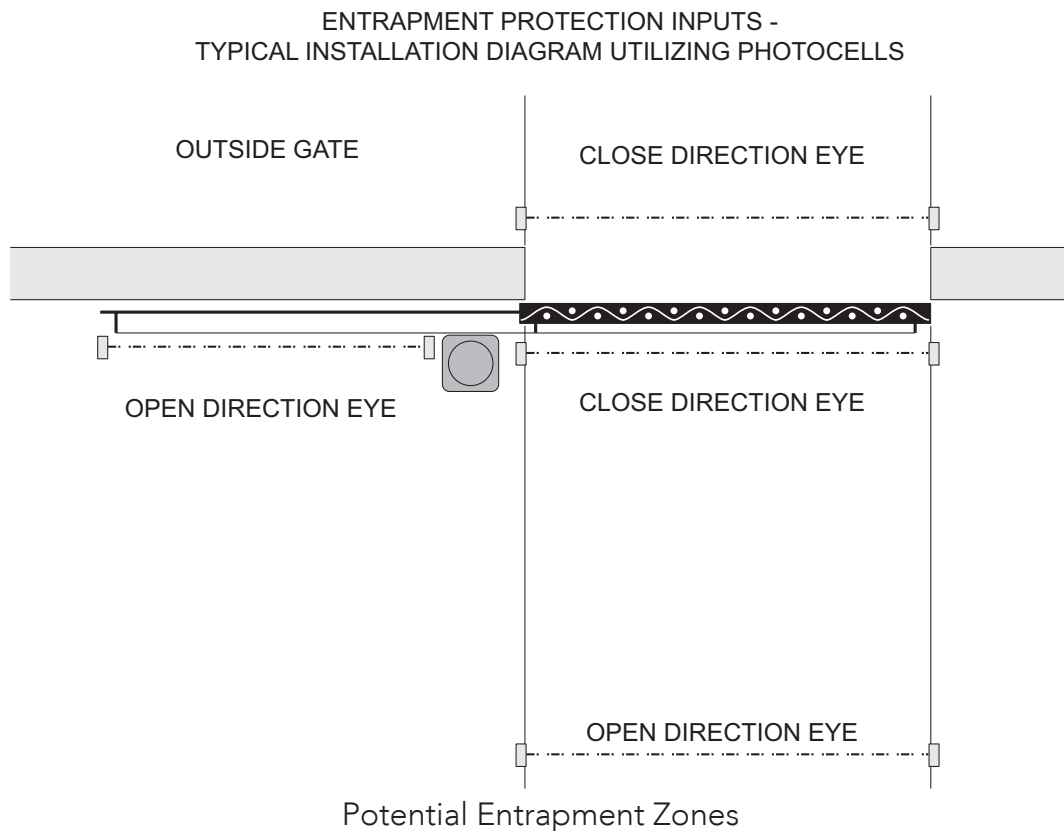

All Nice gate operators feature an Inherent Entrapment System (IES) (UL325 Type A) that monitors the force on the gate during travel. This system protects in both the open and close direction and reverses on contact with an obstruction. This IES system serves as one of the means of entrapment protection.

External sensors must be used to protect against entrapment at each location where an entrapment zone exists. The minimum number of external sensors required to enable automatic operation of the gate operator is as follows:

- Swing Gates: One sensor in the Close direction (provided the gate in the open direction presents no risk of entrapment.)
- Slide Gates: One sensor in the Open direction and one sensor in the Close direction.

The gate operator tests for the presence of these sensors, and if the required minimum number is not found, the operator will only run using continuous pressure on an Open/Close button, either on the controller, or an external device.

## 7. **Compatible External Sensors**

Only the following external sensors have been evaluated and tested with Nice gate systems and are approved to be used for protection against entrapment:

- Nice BlueBus Through-Beam Photo Eyes
- EMX IRB-RET Retro-reflective Photo Eye
- ASO Sentir Series Contact Edge
- Miller Edge GEM-103 Edge Sensor Converter
- EMX WEL-200 Wireless Edge Transmitter/Receiver

## 8 - SLIDE OPERATOR CUTAWAY DRAWINGS

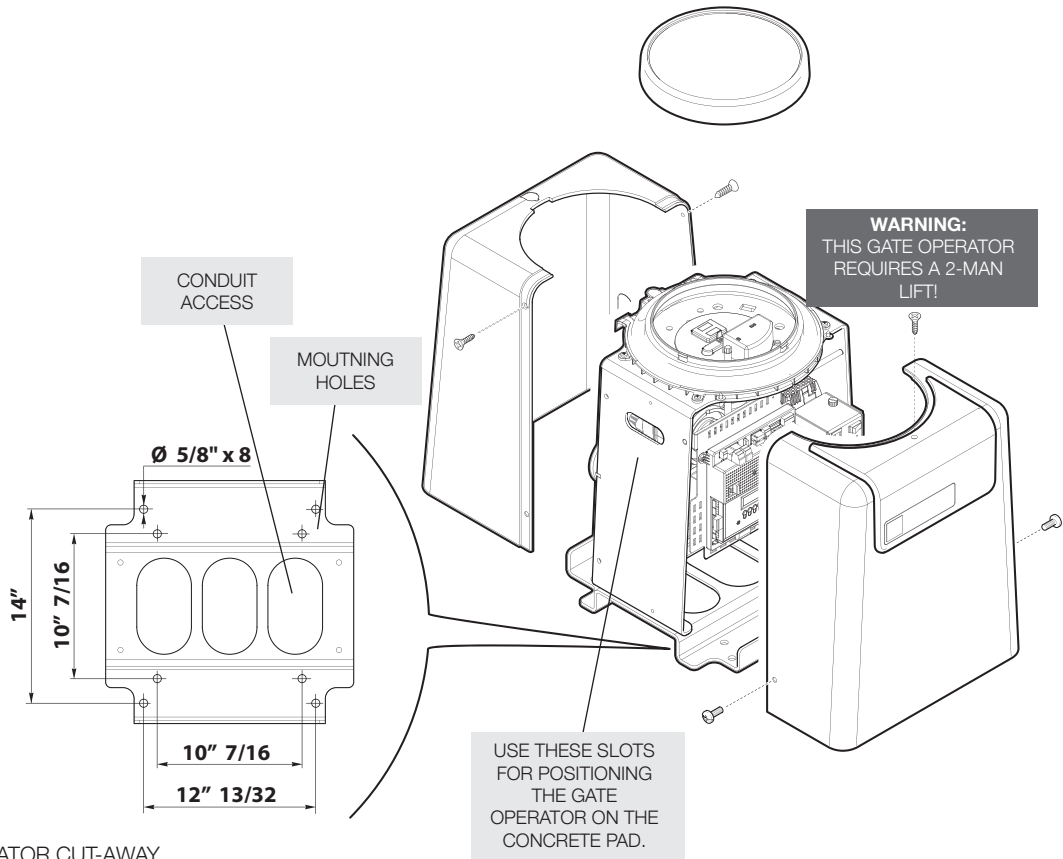

Figure 1 - SLIDE OPERATOR CUT-AWAY

### 8.1 - Slide operator cutaway drawings-cont.

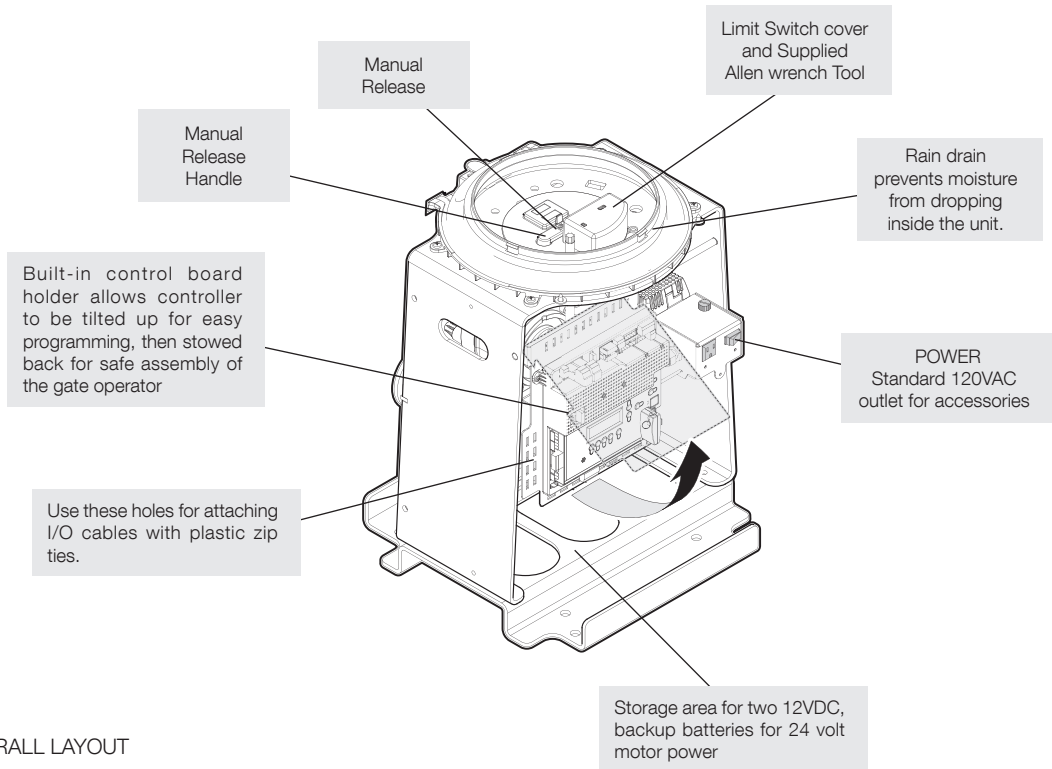

Figure 2 - OVERALL LAYOUT

## 9 - INSTALLATION PROCEDURES

1. Remove top cover assembly by unlocking the lid with the supplied key.
2. Turn lid counterclockwise then remove.
3. Remove side bolts and covers to access interior for installation

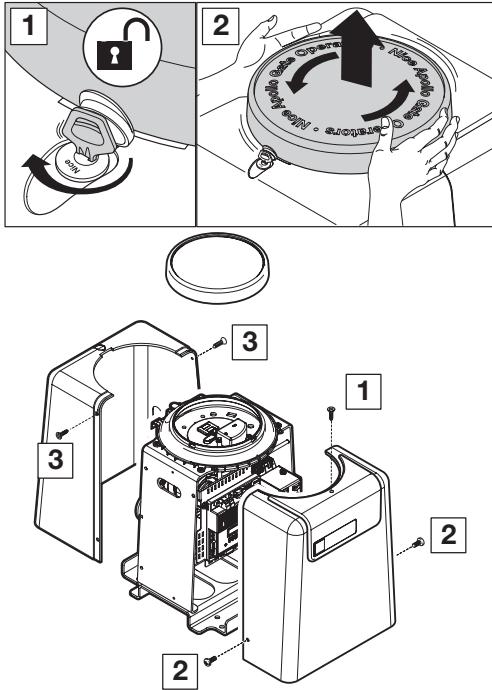

Figure 3 - COVER REMOVAL

### 9.1 - Step one-location

Locate the area in which the opener shall be located.

### 9.2 - Step two-concrete

Fabricate a concrete pad structure sufficient to stabilize and mount the gate opener. Please consult the local building dept. and/or a structural engineer to build a concrete pad that meets building codes and is sufficient for the soil type and climate and capable of supporting the lateral loads imposed by the operator during operation. See figure 4 for proper installation.

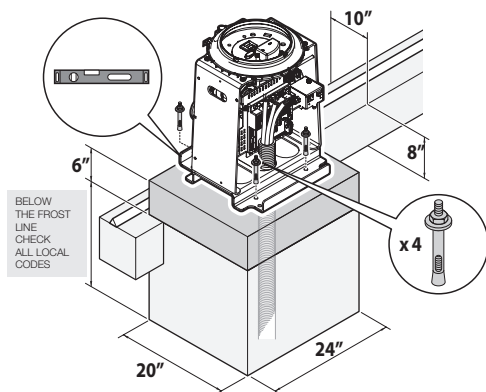

Figure 4 - SAMPLE LAYOUT

### 9.3 - Step three-physical mounting

Drill and insert Redhead (1/2" x 3 1/3") concrete anchors into the concrete sufficient to properly mount the gate opener. Mounting position must be a minimum distance of 4 inches distance between the gate and center chain drive sprocket. (Refer to figure 29) Open the top cover using the supplied key (Refer to figure 3.). Remove the top and side covers to gain access to mounting holes. Set the unit in place and attach wiring as indicated in the wiring section 9.0 Wiring and Connections of this manual.

### 9.4 - Step four-manual release

Locate the manual release handle. Turn the manual release handle counterclockwise until the handle stops. The chain drive assembly is now disengaged and the gate may be operated by hand.

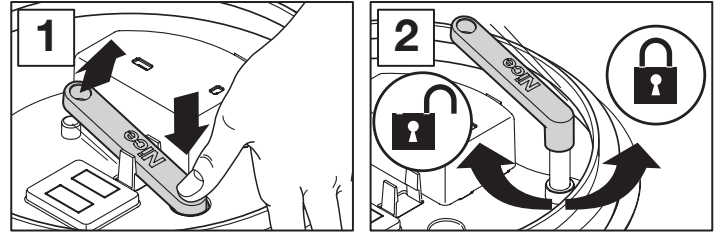

Figure 6 - MANUAL RELEASE

### 9.5 - Step five-chain assembly

Idler sprockets may be adjusted on chassis for different chain height on gate installation. Connect Chain assembly to sprocket assembly and test gate for free movement. (Should move freely in both directions) Push the gate by hand to the full movement in each direction to ensure it does not bind or catch in any manner. (Refer to figures below for diagrams of correct and incorrect installation).

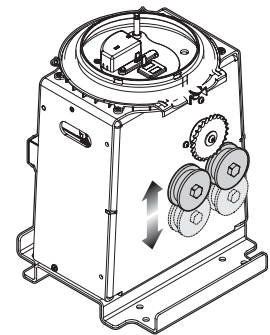

Figure 7 - IDLER SPROCKETS

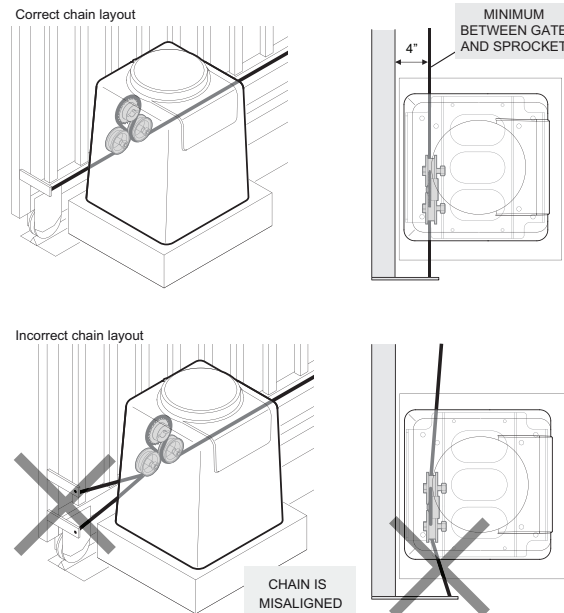

Figure 8 - CORRECT AND INCORRECT CHAIN LAYOUT

## 9 - INSTALLATION PROCEDURES (CONT.)

### 9.6 - Learning and programming

These steps begin the basic "Learning" programming of the gate opener unit. Most all of the features and programming are pre-set and already set up for most standard installations. The installer most often will only be required to plug the unit into electrical power, connect the chain to the sprocket assembly and by setting the limits on the gate movement, and then "learning" the unit. In most cases this is the extent of the basic programming procedure. If the unit is not in LEARNING MODE see section 6.9 to place the unit into this mode. Apollo has taken great care to simplify the installation, operation and safety of this device and to ensure longevity and reliability of the unit over time. The learning procedure consists of the following steps.

### 9.7 - How to setup for first use

1. Install electrical power connections to the gate opener unit. Ensure the power switch is in the OFF position prior to touching any of the power connections. Install all gate accessories such as Photo-Eye's, Sensors, Loops and other safety devices.

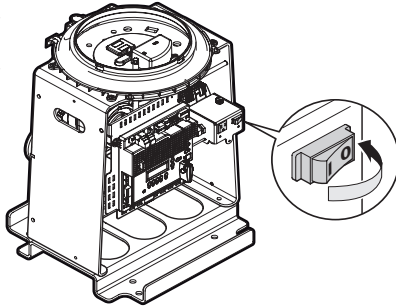

**MAKE SURE ALL POWER IS DISCONNECTED PRIOR TO ANY SERVICE OR INSTALLATION.**

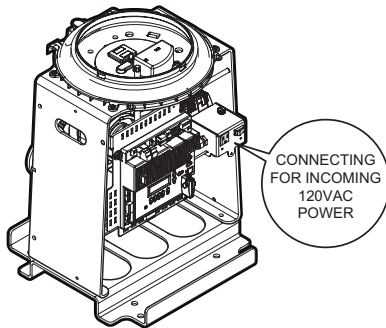

Figure 11 - SETTING UP POWER

2. Using the MANUAL RELEASE HANDLE, Move it counter-clockwise to disengage the drive motor. Ensure that the gate moves freely by moving it manually to the full extents of its travel in both directions verifying there is no binding or cause for resistance.
3. Using the MANUAL RELEASE HANDLE, move it clockwise to re-engage the drive system and then stow the handle.

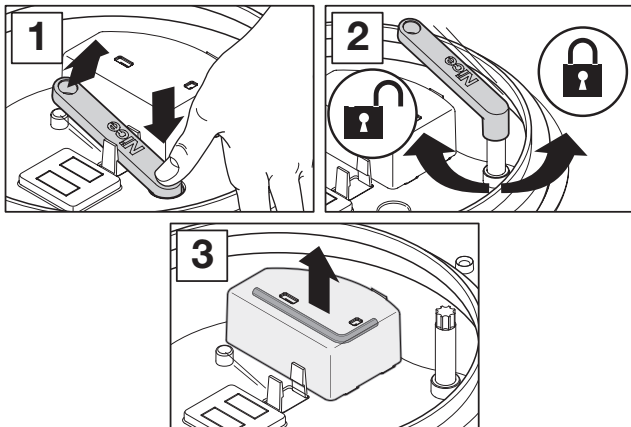

Figure 11 - MANUAL RELEASE

4. Remove the Allen key inside the lid (phase 3 - fig. 9) and then loosen the grub screw of the cams (phase 4 - fig. 11) so that they can be turned freely by hand.
5. Turn on the electrical power to the unit.
6. Using the OPEN button on the front of the Control board, hold the OPEN button down until the gate reaches the fully open position or where the installer wants the gate to stop as FULLY OPEN (see figure 11). If the gate moves the wrong direction, refer to section 16.0 to reverse the direction.
7. Once the gate is in the position where the gate is intended to be "FULLY OPEN" the OPEN limit switch must be adjusted to inform the circuit board that the gate is in the correct position to STOP at that position in the future.

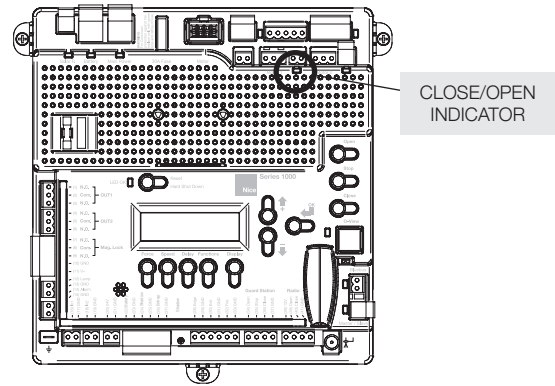

Figure 12 - INDICATOR LIGHT

To adjust the OPEN limit switch on the LOWER CAM (see figure 11) and adjust that Open Limit Switch CAM until the GREEN light (see figure 10) illuminates on the front of the control board. The FULLY OPEN limit switch is now set. Holding it firmly in place, use the supplied allen wrench to tighten the set screw.

8. Using the CLOSE button on the front of the Control Board, hold the CLOSE button down until the gate reaches the fully intended closed position. Once the gate is in the FULLY INTENDED CLOSED position on the UPPER CAM (see figure 12) and adjust the CLOSED Limit Switch CAM until the RED light illuminates on the front of the control board. The FULLY CLOSED limit switch is now set. Holding it firmly in place, use the supplied allen wrench to tighten the set screw.
9. During the course of initial setup, a fine adjustment of the limit switch may be required. Each limit switch CAM has a fine adjustment screw built in to allow the installer to make very small incremental adjustments to ensure the gate reaches the exact position desired. This feature is used after operating the gate to fine tune the exact stopping point. See step 7 in Figure 11 and Figure 12.

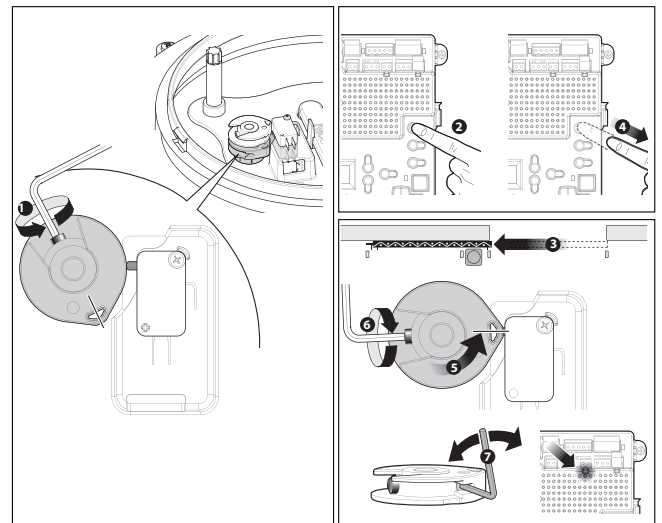
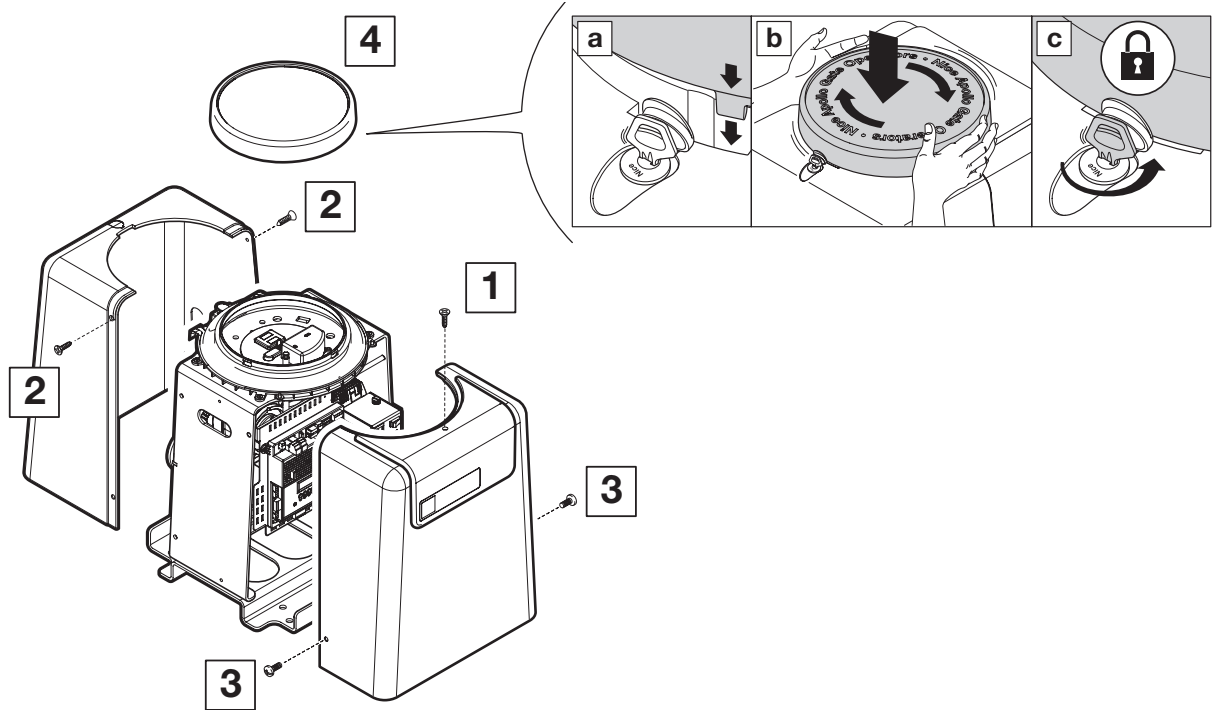

Figure 13 - FULLY OPEN LIMIT SWITCH





## 12 - RE-ASSEMBLING GATE OPERATOR



## 13 - CIRCUIT BOARD LAYOUT

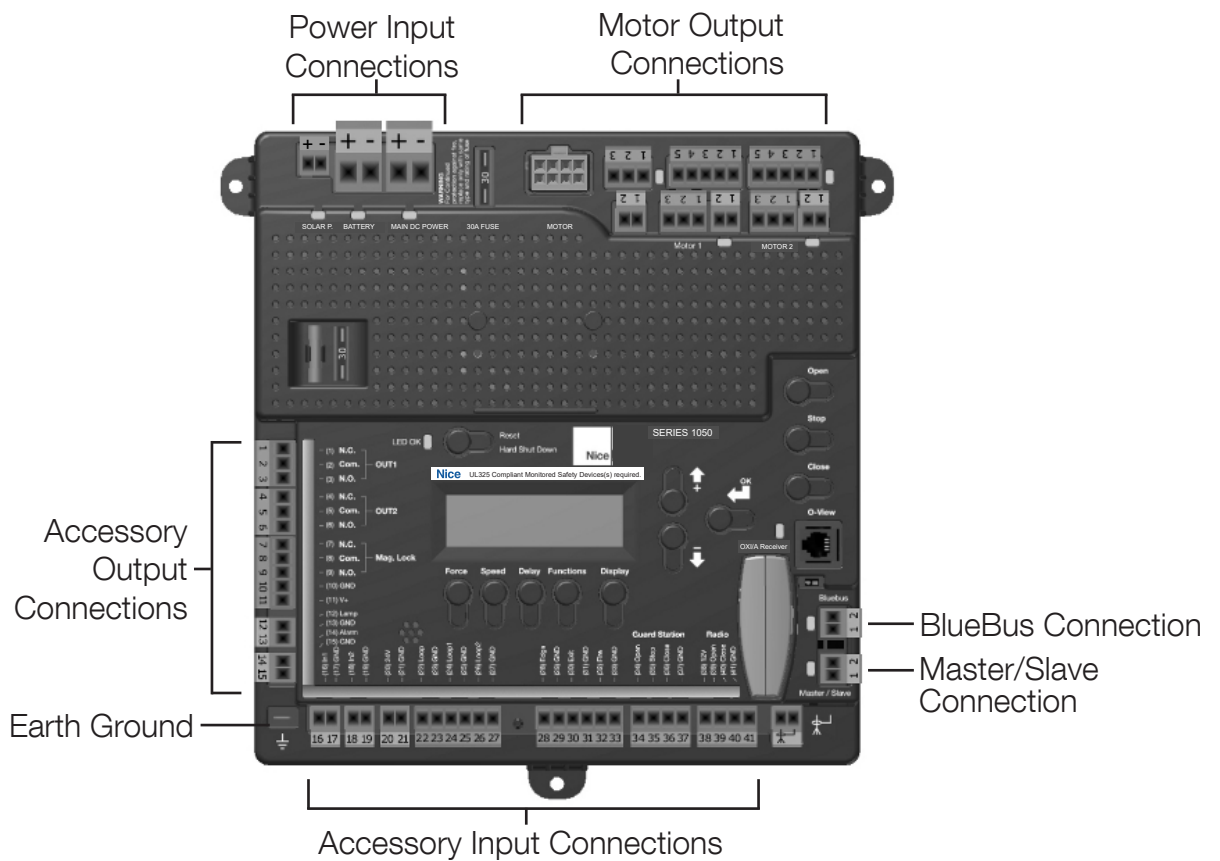

## 15 - SETTING THE LIMIT SWITCHES

When first powered on, the board will scan for any BlueBus photo eyes connected. If at least one eye is not detected, then one of the auxiliary inputs must be programmed to either pulse open or pulse close, with an External Entrapment sensor connected before learn mode is initiated.

**NOTE: The control board is already in the “LEARNING MODE” when shipped.**

If the board is not in “LEARN MODE”, press:

**FUNCTION → OK → SWING → OK → LIGHT → OK**

**AVERAGE**

**HEAVY**

**You are in LEARN MODE if “ENTER” is flashing.**

**For dual gate installations - set one motor at a timerr**

### OPEN LIMIT

Green OPEN LED

1. Using the OPEN button on the front of the Control Board, hold the button down until the gate reaches the fully intended open position.
2. Adjust the Open Limit on the operator until the GREEN light illuminates on the front of the control board as shown above. The fully OPEN limit switch is now set.

**Note:** If red LED illuminates, reverse orange and white limit wires

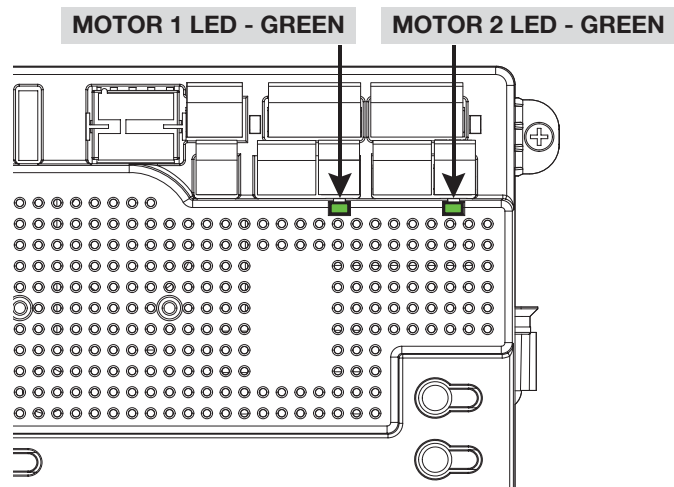

Figure 19 - Open Limit and Motor Connection to Board

### CLOSE LIMIT

Red CLOSE LED

1. Using the CLOSE button on the front of the Control Board, hold the button down until the gate reaches the fully intended closed position.
2. Adjust the Closed Limit on the operator until the RED light illuminates on the front of the control board as shown above. The fully CLOSED limit switch is now set.

**Note:** If green LED illuminates, reverse orange and white limit wires

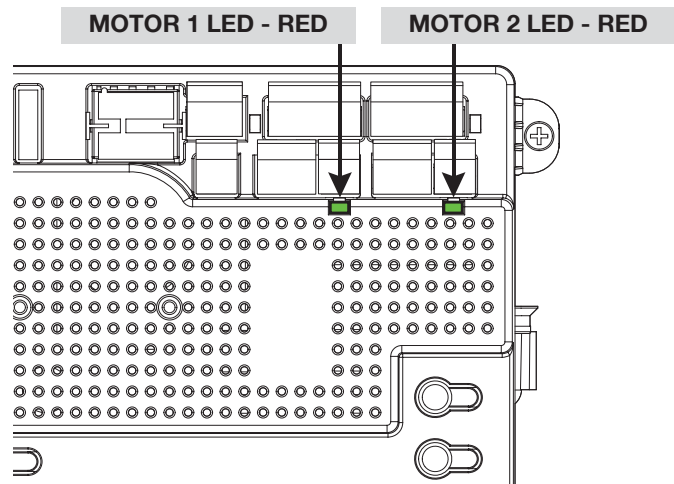
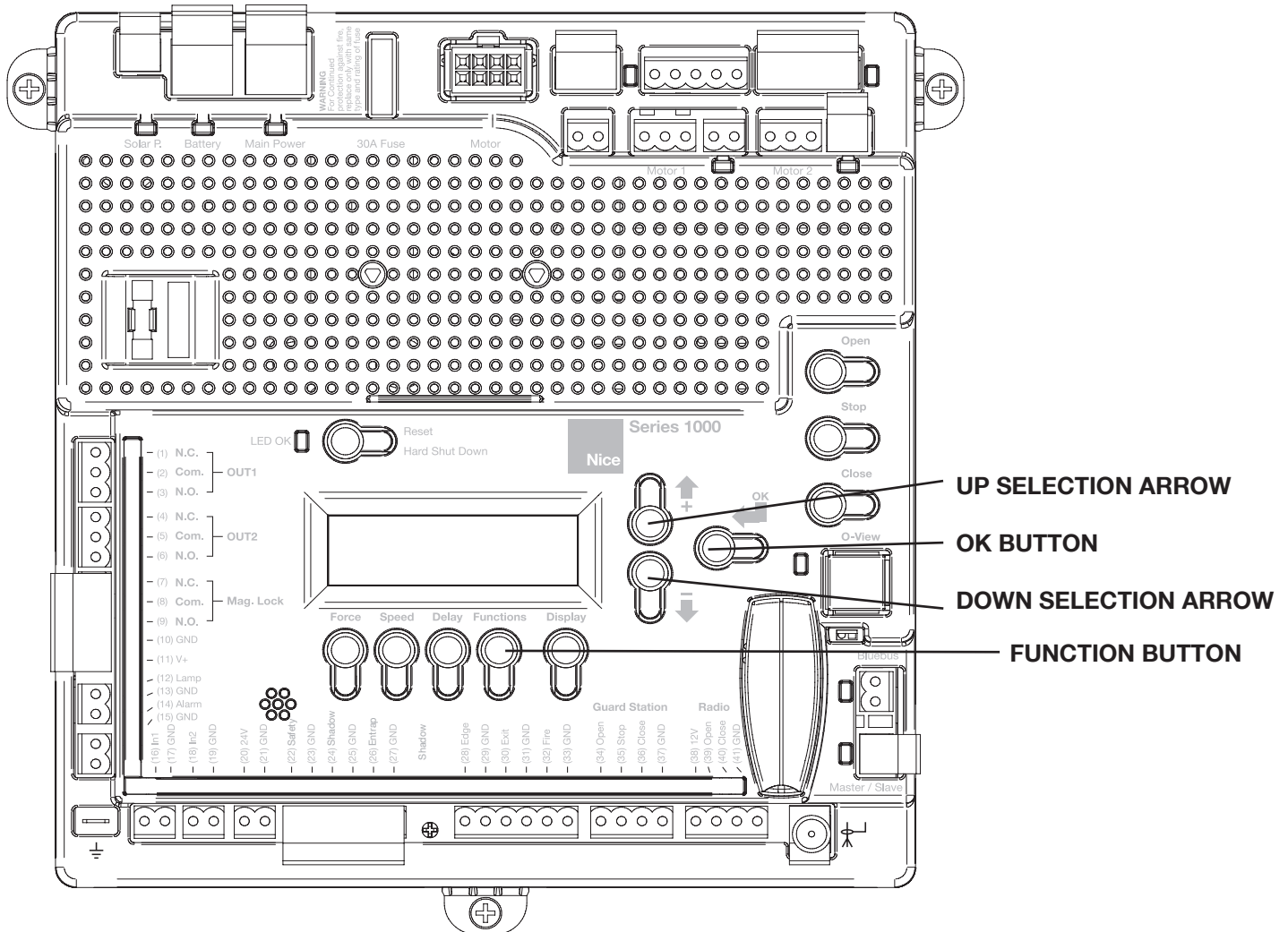

Figure 20 - Closed Limit and Motor Connection to Board

## 16 - LEARNING MODE

Nice has taken great care to simplify the installation, operation and safety of this device and to ensure longevity and reliability of the unit over time. The learning procedure consists of the following steps shown below:



**NOTE:** The control board is already in the “LEARNING MODE” when shipped.

**NOTE:** The learn process will not initiate until the minimum number of external entrapment sensors are connected. One in the open direction and one in the close direction.

**If the board is not in “LEARN MODE”, press:**

FUNCTION → OK → SWING → OK → LIGHT → OK

AVERAGE

HEAVY

You are in LEARN MODE if “ENTER” is flashing.

1. Test the motor direction by pressing and holding CLOSE. If the gate OPENS, swap the RED and BLACK motor leads and retest to verify correct operation. Set limits according to the operators installation manual. **Limits and motor direction MUST be set prior to learning the board!**
2. Press and hold the OPEN or CLOSE button on the gate controller until the gate is 50% open.
3. Press OK to allow the control board to scan for the required monitored entrapment devices. If they are not present, “BLUEBUS ERROR” will be displayed and start the learning sequence. The gate will open partially then stop. This is being done, so that the control board can sense the type and operational condition of the drive motor. The gate will then run to the closing limit (one leaf at a time in case of dual application: “slave” closes first then “master” follows), so that it can properly sense the close limit switch. The gate will then fully open to test the open limit switch then fully close at high speed. The gate should be fully learned by the control board at this point.

The gate opener is now programmed for basic usage.

## 17 - ACCESSORY INPUTS AND OUTPUTS

### 17.1 - Outputs

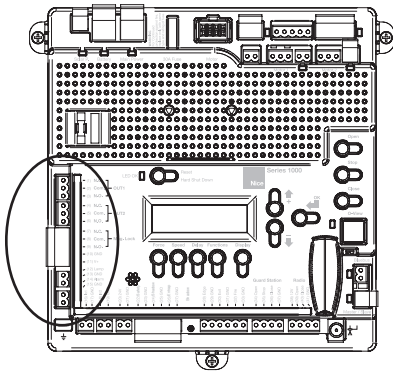

Figure 21 - BOARD OUTPUTS

#### **Commercial Gate Operator Accessory Outputs:**

**OUT1 and OUT2:** Individual, isolated relays provide COMMON, NORMALLY OPEN, and NORMALLY CLOSED dry contacts (35V 5A max) for switching accessories based on programming of the "Auxiliary IO" function. These outputs are programmed in the "FUNCTION Auxiliary I/O" menu.

**Magnetic Lock:** Provides fused power (1.85A max) and isolated relay COMMON, NORMALLY OPEN, and NORMALLY CLOSED dry contacts (35V 5A max) for electrically powered and maintained magnetic locks. The delay for magnetic lock activation/deactivation may be adjusted from 0 to 5 seconds.

**Lamp:** Provides fused power (1.85A max) to drive a flashing warning lamp to indicate gate operation. This output is active when the gate is operating (Opening and Closing). Sets the amount of time the lamp accessory output is activated prior to gate movement. Settings from 0 to 5 seconds with a step of 0.5 seconds.

**Alarm:** Provides fused power (0.5A @ 12VDC) to drive an alarm siren to signal the occurrence of a hard shutdown, caused by 2 consecutive entrapment events (signals). This alarm output is reset by pressing the "Reset Hard Shutdown" button on the front panel or activating the "FIRE" input.

### 17.2 - Inputs

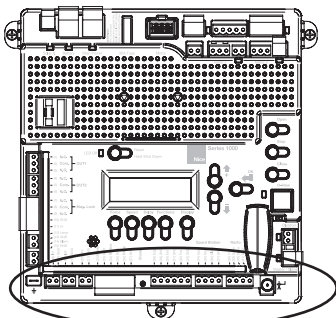

Figure 22 - INPUTS

#### **GATE OPERATOR ACCESSORY INPUTS:**

**Auxiliary Inputs 1 (16), 2 (18):** These digital inputs may be connected to the digital outputs of accessories and programmed to activate or control the gate operator in a number of different modes. Shorting the pins through a dry contact activates the programmed settings for these inputs. These inputs are programmed in the "FUNCTION Auxiliary I/O" menu.

**SAFETY Input:** (22) Dry contact input that can be programmed for an inductive loop or photo-eye detector. Shorting the Safety Input (22) to GND reverses a closing gate to the full open position. The opened gate is held opened for as long as the input is active. This input is not for external entrapment sensors.

**SHADOW Input:** (24) Dry contact input that can be programmed for an inductive loop or photo-eye detector. Shorting the Shadow Input (24) to GND maintains an OPEN gate fully open and a CLOSED gate fully closed until deactivated.

Setting the Shadow Input to "Photo Mode" causes the opening gate to stop, then reopens the gate when the Shadow Input is deactivated.

**ENTRAP Input:** (26) Dry contact input that can be programmed for an inductive safety loop or photo-eye detector. Shorting the ENTRAP input (26) to GND while the gate is opening cause the gate to close to the fully closed position. This input is not for external entrapment sensors.

**EDGE Input:** (28) This input may be configured as "DIGITAL" or "ANALOG" as required by the sensor type. When configured as "DIGITAL", this is a dry contact input; otherwise when configured as "ANALOG", additional options are available to declare if the edge is protecting the open or close direction, and the input must measure 8.2K - 10K. When the input is activated it stops the gate regardless of direction of travel, momentarily reverses it then stops.

**EXIT Input:** (30) Dry contact input for a vehicle exit sensor. Shorting the EXIT input to GND opens gate from the closed position and holds gate open with maintained input or reverses gate if closing.

**FIRE Input:** (32) Dry contact input for a fire department control switch. Shorting the Fire input (32) to GND opens the gate and holds the gate open until the control switch is deactivated. This input is "hold to run". Auto-close is disabled when this input is activated. Also clears hard shutdown.

#### **GUARD STATION**

**Guard Station OPEN:** (34) Dry contact input for a guard station open switch. Momentarily shorting the Open input (34) to GND opens the gate to the full open position with the subsequent auto-close feature enabled.

**Guard Station STOP:** (35) Dry contact input (Normally Closed) for a guard station stop switch. Momentarily opening the Stop input (35) stops the opening gate at its current position. While this input is activated, all other inputs are disabled and are not functional.

**Guard Station CLOSE:** (36) Dry contact input for a guard station close switch. Momentarily shorting the Close input (36) to GND closes the gate (master and slave).

#### **RADIO**

**Radio Open:** (39) Dry contact input for an accessory radio open switch. Momentarily shorting the Open input (39) to GND opens the gate to the full open position with the subsequent auto-close feature enabled.

**Radio Close:** (40) Dry contact input for an accessory radio close switch. Momentarily shorting the Close input (40) to GND closes the gate.

**Radio Input:** Open/Close: (39 and 40) If you tie open and close together the unit will operate as a Step by Step command each time the input is shorted to GND, it will either OPEN, STOP or CLOSE.

### 17.3 - Communication bus

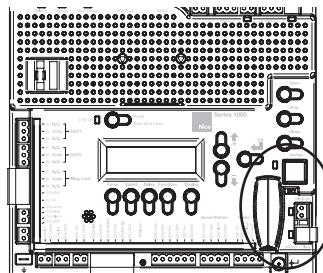

Figure 23 - COMMUNICATION BUS

#### **OVIEW**

Programming and diagnostic unit which connects directly to the gate controller and is part of the Nice "Opera" control system. The unit can be used in "stand-alone" mode via its front-panel keypad, or it may be accessed via a Bluetooth or cellular-enabled PDA, PC, or Smartphone when used with the O-View Software Suite. This unit, when matched with the OVIEW Bluetooth or

## 17 - ACCESSORY INPUTS AND OUTPUTS (CONT.)

GSM modules, enables remote control O-View Software Suite. This unit, when matched with the OVIEW Bluetooth or GSM modules, enables remote control and management of the gate controller. Remote control functions include all programming functions that are available at the front panel LCD on the control board as well as software updates.

**OVBT:** Bluetooth module for OVIEW and the "O-View Software Suite" application for PC, PDA, or Smartphone for localized wireless control of the gate controller.

**OVBTGSM:** GSM module that plugs into the OVIEW and provides cellular phone access through the "O-View Software Suite" application for PC, PDA, or Smartphone, for wireless local, national, and international controller of the gate controller.

**O-VIEW Software Suite:** Provides desktop or Smartphone level control of the gate controller. Other benefits include software updates that can be made wirelessly as new versions of software are made available.

### BLUEBUS ACCESSORIES

**ERA Series Photo Eyes:** Photocell transmitter and receiver pair that connects to the 2-wire BlueBUS connector with unshielded twisted-pair wire and is a non-contact sensor for entrapment protection as specified in UL325, Section 31.1 "General Entrapment Protection Provisions". Up to six pairs of eyes may be connected.

### MASTER/SLAVE - ONLY USED IN 24V COMMERCIAL OPERATORS

The gate operator includes a two-pin connector designed to link two separate gate operators together as a Master/Slave pair. The Master/Slave configuration is enabled by connecting two gate operators with simple, unshielded twisted-pair wire (Max. 100 ft.). All entrapment sensors, switch inputs, receiver controls, and outputs must be wired to the gate operator designated as the "Master". The following procedure outlines the process for configuring the Master/Slave pair.

Perform the "Learn" process to configure open and close limits with the gate for each operator. See the "Programming Quick Start" procedures in this manual for a description of the gate learning process.

On the Master operator, select Function -> Adv. Settings -> Remote Mst. Slv.

Then select On -> Master. The red LED associated with the Master/Slave connector will illuminate.

On the Slave operator, select Function -> Adv. Settings -> Remote Mst. Slv. Then select On -> Slave. The red LED associated with the Master/Slave connector will illuminate.

The Master/Slave pair is now configured. The Slave gate operator will perform identical open/close/stop functions in tandem with the Master gate operator.

### 17.4 - Programming the plug-in receiver and remote controls

**Nice Plug in Receiver:** The Nice 433Plug-In Receiver provides up to 15 channels for specific control of individual gate functions. The receiver includes built-in programming functions for adding or removing Nice wireless remote controls to/from a gate installation. The following procedures detail the steps to assign a remote control, add a new remote control, delete a single remote control, or remove all remote controls from the receiver memory.

#### Programming the Nice 2-Button or 4-Button Remote Control with the Nice Plug-In Receiver.

These procedures apply to the Nice wireless remote control. These procedures assign factory default controls automatically to the remote control.

1. Have a functioning Nice 2-button or 4-button remote control with a battery installed prior to programming the remote control.
2. Press and hold the button on the side of the Nice receiver until the led illuminates green on the Nice receiver, then release the button.

3. Within 10 seconds, press and hold any key on the Nice remote control until the led in the Nice receiver blinks green 3 times, indicating that the Nice is programmed to control the receiver.
4. After the led on the Nice receiver blinks green 3 times, another 10 second interval is started to program another Nice remote control if desired. Repeat step 3 to program the additional Nice remote control (transmitter). Step 3 may be repeated as many times as necessary to program all available Nice remote controls.
5. Verify that the Nice remote control(s) can control the gate by pressing one or more buttons individually on the remote control(s).

#### Add new remote control to the Nice Plug-In Receiver

A Nice remote control that has been programmed to control a Nice receiver may be used to create other Nice remote controls for the same receiver. This procedure needs to be performed within 10 to 20m (30 to 60 feet) of the Nice receiver, but the Nice receiver does not need to be physically accessed.

1. Press and hold any button on the non programmed Nice remote control for at least 5 seconds, then release the button, taking note of the button that was pressed.
2. Press the same button on the programmed Nice remote control three times.
3. Press the same button in step 1 on the non programmed Nice remote control and release.
4. It is recommended to test the new copy of the Nice remote control with the assigned gate controller.

**NOTE:** This procedure will affect all Nice receivers within radio range.

#### Deleting a Single Nice Remote Control from the Nice Plug-In Receiver Memory

A Nice remote control that has been programmed to control a Nice receiver may be removed from the Nice receiver memory without affecting other assigned remote controls. This procedure needs to be performed at the Nice Plug-In Receiver with the affected Nice remote control.

1. Press and hold the button on the side of the Nice receiver until the led on the Nice receiver illuminates green and keep the button pressed. The led will illuminate after approximately 4 seconds.
2. Press and hold any button on the Nice remote control until the led on the Nice receiver blinks 5 green flashes
3. Release the button on the side of the Nice receiver.
4. It is recommended to verify that the non programmed Nice remote control no longer controls the gate.

#### Deleting all Nice transmitters from the Nice Plug-In Receiver Memory.

All programmed remote controls may be removed from the Nice plug in receiver memory. This procedure needs to be performed at the gate controller.

1. Press and hold the button on the side of the Nice receiver until the led on the Nice receiver illuminates green and keep the button pressed.
2. Watch the led and on the receiver and verify the following sequence in the led.
3. Within 4 seconds after pressing the button (approx.) the green led illuminates.
4. Within 8 seconds after pressing the button (approx.) the green led turns off.
5. Within 12 seconds after pressing the button (approx.) the green led starts flashing
6. Count the green led flashes on the Nice receiver. On EXACTLY the 3<sup>rd</sup> flash, release the button on the Nice receiver.
7. It is recommended to test the Nice remote controls, if available, with Nice plug in receiver to verify that it no longer affects the gate controller.

## 18 - 120VAC WIRING AND CONNECTIONS

**DO NOT WIRE AC POWER TO THE 1050 CONTROL BOARD!**

**THE CONTROL BOARD OPERATES ON 10 - 32 VDC ONLY!**

**This section is intended for residential systems where a 120VAC transformer will be used**

**Permanent wiring is to be employed for the installation as required by local codes.**

Use only U.L. listed (or equivalent) non-contact sensors. Inputs from the photo-beam to the circuit board are Normally Open (N.O.). Use only U.L. listed (or equivalent) non-contact sensors.

Connect the non-contact sensors. Inputs from the photo-beam to the circuit board are Normally Open (N.O.). Photo-beam input shall REVERSE travel of gate when activated during the CLOSE CYCLE ONLY. Gate will resume normal operation when photo-beam is no longer activated.

To reduce the risk of SEVERE INJURY or DEATH;

- Disconnect power to the gate operator by manually opening its dedicated circuit breaker before making any mechanical or electrical adjustments.
- Use a 20 Amp dedicated circuit breaker for each installed gate operator
- Open dedicated circuit breaker supplying power to this gate operator BEFORE a new installation or making any modifications to an existing installation of this gate operator.
- All wiring connections MUST be made by a qualified individual.
- Run individual circuits in separate U.L. listed conduits. Do not combine high voltage (120VAC) power wiring and low voltage (+12VDC to +24VDC) control wiring in the same conduits.
- It is highly recommended that a grounding rod be installed with each operator according to local building codes to provide protection against near lightning strikes. Contact local underground utility companies BEFORE digging.
- Use the information in Table 1 to determine high voltage wire size requirements. The distance shown in the chart is measured in feet from the operator to the power source. If power wiring is greater than the maximum distance shown, it is recommended that a service feeder be installed. When large gauge wire is used, a separate junction box must be installed for the operator connection. The wire table is based on stranded copper wire. Wire run calculations are based on a 110 VAC power source with a 3% voltage drop on the power line, plus an additional 10% reduction in distance to allow for other losses in the system.

**Table 1 - Wire Gauges and Maximum Power Circuit Distances**

110V AWG	14	12	10	8	6	4
MAX RUN (ft)	180	280	460	700	1150	1800

The gate operator system should be grounded through the earth ground in the AC mains wiring system (GREEN WIRE). This ground connection will prevent dangerous currents from appearing on the metal control box, the actuator, or the gate itself.

**DO NOT WIRE AC MAINS POWER TO THE METAL CONTROL BOX WITHOUT AN EARTH GROUND CONNECTION!**

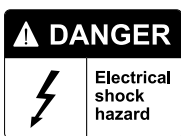

## 19 - SOLAR PANEL CHART

This NICE Gate Operator is 12 Volt DC (Direct Current) powered. A 12 Volt sealed battery (33 ampere hour minimum for AC charged systems, 70 ampere hour minimum for solar charged systems) with connecting posts located on the top is recommended.

The following table should be used as a guide for capacity of operation of operators only, additional options and accessories may reduce the daily usage.

Please note that the charge capability of solar panels will vary with different geographical locations.

Daily cycles	1-10	1-20	1-40	1-60	1-80	80+
5 watt solar panel	*					
10 watt solar panel		*				
20 watt solar panel (requires regulator)			*			
30 watt solar panel (requires regulator)				*		
40 watt solar panel (requires regulator)					*	
1.5 amp battery charger					*	
10 amp battery charger						*

**Note: Double the amount of solar wattage for dual gate operators  
Double the amount of panels for a 24VDC system**

Nice operators with the 1050 board that are used in solar applications need to be put into "Standby" mode.

To do this, press Functions – scroll to #8 "Standby" – Press OK – Scroll to desired amount of time before system enters Standby mode – Press OK. Once this is done, the operator will enter a Standby mode after the set time when the operator is not moving or in the auto-close countdown.

Things to note in Standby:

1. Display will be off and only a "heartbeat" will be present at the LED OK
2. Voltage at #20 (24 volts) and #38 (12 volts) will turn off. **DO NOT POWER ENTRY OR EXIT DEVICES HERE**
3. BluBus connection is non functional
4. Primary/Secondary synching is non functional (used for commercial operators only)

Connection of the solar panel(s) may be made at the top left corner of the board at "Solar P" (regulated charging to the "Battery" via the controller in the board) – note that the maximum output of the regulator in the 1050 board is 1.5A. If the installation requires larger than a 30W solar panel – an off-board regulator should be used and connected directly to the battery.

## 20 - OPTIONAL INPUTS

### 20.1 - Fire dept. connection

32 FIRE  
33 GND

Dry contact input for a fire department control switch. Normally Open (NO) contact must be shorted to ground through a switch to open the gate. The FAIL SAFE connector which is shorted at the factory with a jumper (Normally Closed NC), may be wired in parallel with the Fire input to release the motor in the event of an emergency entry by the fire department during a power failure.

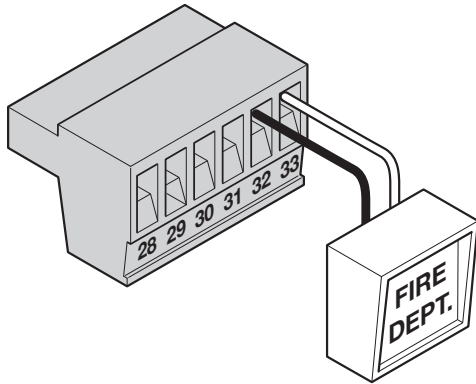

Figure 25 - FAIL SAFE CONNECTOR

### 20.2 - Fail safe connection

A "fail safe" electric motor brake is provided for each of the three motor control outputs on the main gate control board. A jumper is installed at the factory for the primary motor control as shown in figure 21 to activate this electric brake. This jumper creates an effective brake action on the motor that does not allow the gate to be operated (opened or closed) manually, whether or not the gate operator is powered. This jumper may be removed during a power outage to enable operation of the gate manually, or during installation, the jumper may be removed and this connector may be wired to an external switch for more convenient access. The fail safe jumpers for the Motor 1 and Motor 2 control provide the same electric brake function for external gate motors in alternative installations.

Fail Safe connector with jumper installed on the Primary motor control connectors

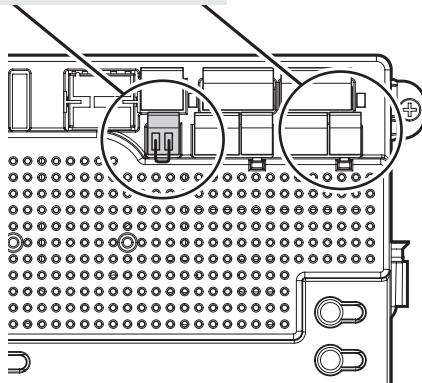

Figure 26 - FAIL SAFE CONNECTION

### 20.3 - Magnetic lock connection

7 NC  
8 Com (Common)  
9 NO  
10 GND  
11 V+ (Voltage is determined by incoming power supply)

This connection is used to install the magnetic lock. In this instance a gate can be locked magnetically to prevent a forced opening. Connections to this may be different than shown. Consult lock manual for specifics on installation and wiring.

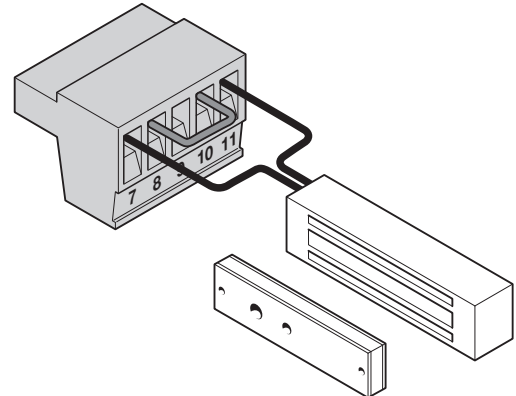

Figure 27 - MAGNETIC LOCK CONNECTION

### 20.4 - Guard station connection

34 OPEN  
35 STOP  
36 CLOSE  
37 GND

With a Guard Station switch in place, a user could operate the gate by pushing the respective buttons for the command that is desired. Gate Open, Stop, and Close dry contact inputs, controlled by NORMALLY OPEN (NO) and NORMALLY CLOSED (NC) momentary switches.

**NOTE:** If guard station inputs are not used, STOP (35) and GND (32) need to be tied together.

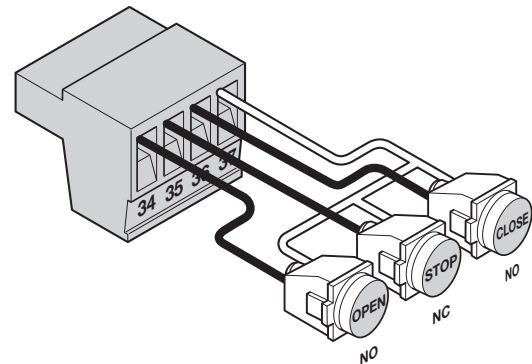

Figure 28 - GUARD STATION CONNECTION



## 20 - OPTIONAL INPUTS (CONT.)

### 20.5 - Exit and edge inputs wiring diagram

28 EDGE  
29 GND  
30 EXIT  
31 GND

The EDGE input may be configured as a monitored ANALOG input, or DIGITAL (NC or NO) input. The EDGE sensor input is intended for ANSI/UL 325 listed gate edge sensors to protect against entrapment and hazardous pinch points along the moving edge of the closing gate. The EXIT sensor input is provided to activate to open the gate, or re-open a closing gate, upon sensing an exiting vehicle.

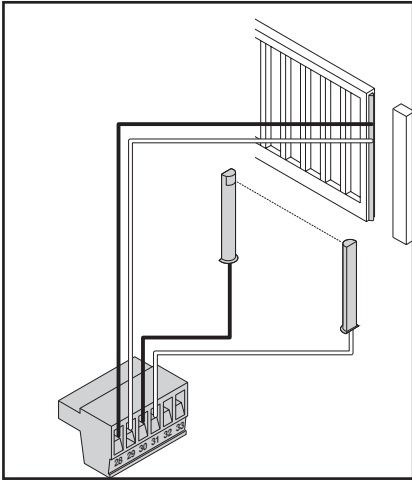

Figure 29 - EXIT AND EDGE INPUTS

### 20.6 - Radio receiver connection (third party)

38 12V  
39 OPEN  
40 CLOSE  
41 GND

The customer supplied radio receiver allows the gate operator to be operated via remote, such as wireless key-card readers or user remote controls. Connecting the Open (39) and Close (40) pins together with a receiver enables single-button gate control. This configuration allows a single button to control the gate in the following sequence:

Press - Gate Open  
Press - Gate Stop  
Press - Gate Close  
Press - Gate Stop

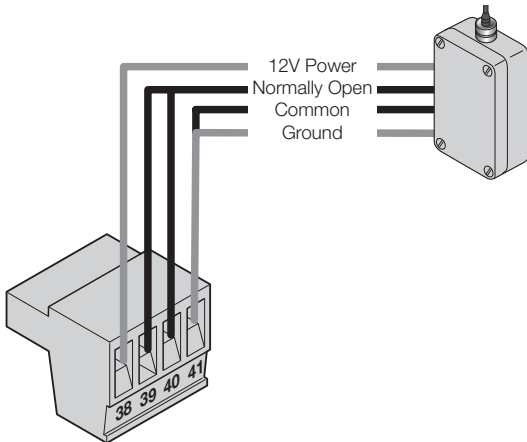

Figure 30 - RADIO RECEIVER CONNECTION

### 20.7 - Optional power output

10 GND  
11 V+

When the control board is in standby mode, power is still present at terminals 10 and 11. If standby mode is to be used (especially in a solar application) You may use the terminals 10 and 11 to provide power to accessories. Please note that the output voltage of terminal 11 is the same as the highest incoming voltage (on battery OR main power) to the control board.

For example:

If you are using a 12VDC battery to power to the control board connected to the Battery input, and the voltage of the battery is 13.5VDC - terminal 11 will have a 13.5VDC output.

If you are using a power supply input of 32VDC to the control board connected to the Main Power input - terminal 11 will have a 32VDC output.

If you are using a power supply connected to Main Power (at 32VDC) and also using a battery connected to the Battery input (at 13.5VDC) - terminal 11.

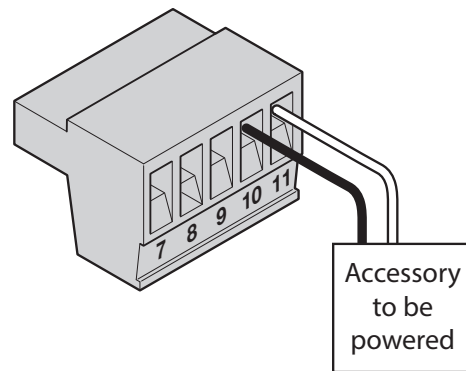

Figure 31 - RADIO RECEIVER CONNECTION

## 21 - INSPECTION AND OPERATION

Proper inspection of all equipment is required to ensure continuous functionality, safety and to ensure reliable operation in all weather conditions. Inspect electrical assemblies and wiring installations for damage, general condition, and proper functioning to ensure the continued satisfactory operation of the electrical system. Adjust, repair, overhaul, and test electrical equipment and systems in accordance with the recommendations and procedures in the OPENER and/or component manufacturer's maintenance instructions.

Replace components of the electrical system that are damaged or defective with identical parts, with manufacturer's approved equipment, or its equivalent to the original in operating characteristics, mechanical strength, and environmental specifications. A partial list of suggested problems to look for and checks to be performed are listed below:

- 21.1** Damaged, discolored, or overheated equipment, connections, wiring, bearing caps and installations.
- 21.2** Excessive heat or discoloration at high current carrying connections. (look for bluing or heat affected metal).
- 21.3** Misalignment of electrically driven equipment. (Causes strain on pulley assemblies and bearings).
- 21.4** Poor electrical bonding (broken, disconnected or corroded bonding strap) and grounding, including evidence of corrosion.
- 21.5** Dirty equipment and connections. Clean equipment and connections.
- 21.6** Improper, broken, inadequately supported equipment, wiring and conduit, loose connections of terminals, and loose ferrules.
- 21.7** Poor mechanical or weld joints. Broken welds.
- 21.8** Condition of circuit breaker and fuses. Ensure that they are of the correct type and amperage.
- 21.9** Insufficient clearance between exposed current carrying parts and ground or poor insulation of exposed terminals. All exposed connections must be covered (prevent arcing between exposed parts, and electrical shock).
- 21.10** Broken or missing wire, connectors, etc.
- 21.11** Operational check of electrically operated equipment such as motors, inverters, generators, batteries, lights, protective devices, etc. Ensure proper functionality of all systems during inspections.
- 21.12** Ensure safety placards and warning signs are present as specified within this document. Ensure proper functionality of all safety devices as specified. Non-functioning or malfunctioning safety devices should be replaced immediately.

## 22 - GENERAL LAYOUT AND SAFETY ACCESS

Entrapment Protection Inputs - Typical Installation Diagram Utilizing Loop Sensors and Photocells

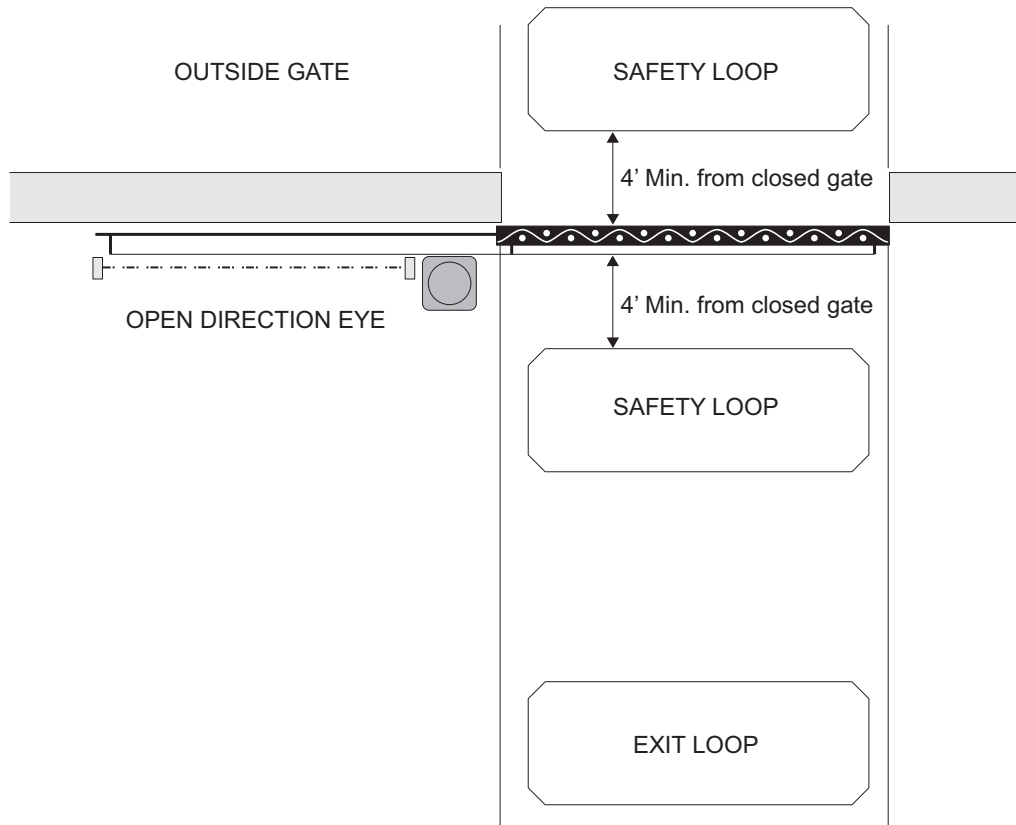

Figure 32 - LAYOUT FOR IN-GROUND LOOPS

### ENTRAPMENT PROTECTION INPUTS - TYPICAL INSTALLATION DIAGRAM UTILIZING PHOTOCELLS

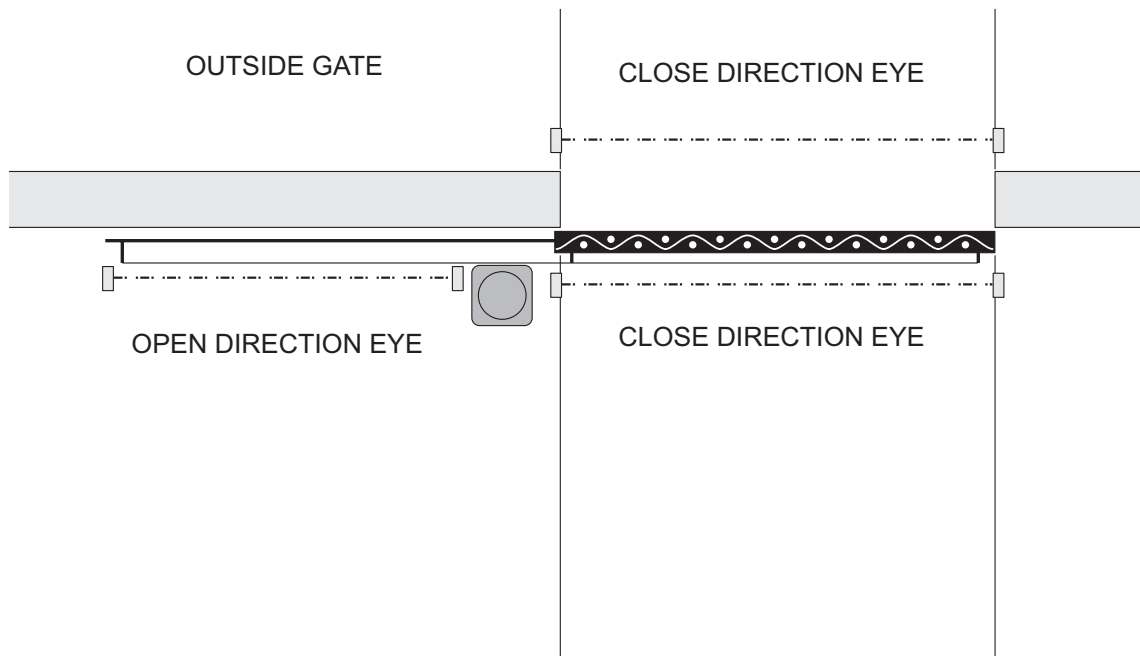

Figure 33 - LAYOUT FOR ENTRAPMENT SENSORS

**EXTERNAL ENTRAPMENT PROTECTION**

Non-contact and contact sensors must be installed individually or in combination with each other to provide external entrapment protection.

Care should be exercised to reduce the risk of nuisance tripping, such as when a vehicle trips the sensor while the gate is still moving, and one or more non-contact sensors shall be located where the risk of entrapment or obstruction exists, such as the perimeter reachable by a moving gate or barrier.

A hardwired contact sensor shall be located and its wiring arranged so that the communication between the sensor and the gate operator is not subjected to mechanical damage.

A wireless contact sensor such as one that transmits radio frequency (RF) signals to the gate operator for entrapment protection functions shall be located where the transmission of the signals are not obstructed or impeded by building structures, natural landscaping or similar obstruction.

**DURING INSTALLATION**

- DISCONNECT POWER at the control panel before making any electric service power connection.
- Be aware of all moving parts and avoid close proximity to any pinch points.
- Know how to operate the manual release.
- Adjust the unit to use the minimum force required to operate the gate smoothly even during mid-travel reversing.
- Place controls a minimum of 8 feet away from the gate so that the user can see the gate and operate controls but cannot touch the gate or gate operator while operating the controls.
- Warning signs must be placed on each side of the gate or in high-visibility areas to alert of automatic gate operations.



**23.1 - MONITORED SAFETY DEVICE TYPES**

**BlueBus photo-eyes:**

The EPMOB photocell is a thru-beam device - consisting of a transmitter (TX) and a receiver (RX) that connects via two (2) wires. Polarity of the wiring is not important. EPMOBs may be wired in parallel to one another or directly to the board - it is not necessary to make a "home run" to the board with each EPMOB. Multiple sets of EPMOBs may be used, however each PAIR must be set to an exclusive address by setting the jumpers in the units. What this means, is that each pair of eyes must have their jumpers set to match each other - but every pair must be set differently from the other pairs. The address jumpers also determine the functionality of each set of eyes: Open direction or close direction, etc. (see Table 1)

Table 1	
Photocell	Jumpers
CLOSE DIRECTION A	
CLOSE DIRECTION B	
CLOSE DIRECTION 2A	
CLOSE DIRECTION 2B	
OPEN DIRECTION A	
OPEN DIRECTION B	
NOT USED	

1. Mount the transmitter and receiver appropriately to a rigid mounting surface. Eyes should be placed appropriately to protect areas of entrapment according to UL325 guidelines.
2. Set the jumpers in each pair of eyes to match each other. Ensure that each pair of eyes are set differently. Use the table below to find the setting of the jumpers that corresponds to the functionality desired from each pair of eyes.
3. Connect the EPMOBs to the Bluebus connector of the circuit board. Polarity of the wiring is not important. Eyes may be connected in parallel to one another - or directly to the board.
4. LEARN the Bluebus port.  
On a 1050 board - Press Functions (1. Learn) - Press "OK" (Learn Bluebus) - Press "OK". Allow the board to scan the Bluebus Port.  
When complete - test the functionality of each set of eyes.
5. Fine tune the alignment of each pair of eyes. The more slowly the lights flash on the units - the better they are aligned.

**Close Direction A/B:** Resets timer to close in open position, reverses gate if closing, no effect if gate is closed or during opening cycling. Typically used when the photo eyes are on the outside of the property (gates opening inward).

**Close Direction 2 A/B:** Resets timer to close in open position, reverses gate if closing AFTER obstruction is cleared, pauses the gate on opening cycle - opening resumes after obstruction clears. Typically used when the photo eyes are on the inside of the property (gates opening inward).

**Open Direction A/B:** Delays gate opening from closed position. Stops and reverses gate back closed on open cycle. Typically used to protect an entrapment point when the gates are opening.

## 24 - IRB-RET Wiring Diagram

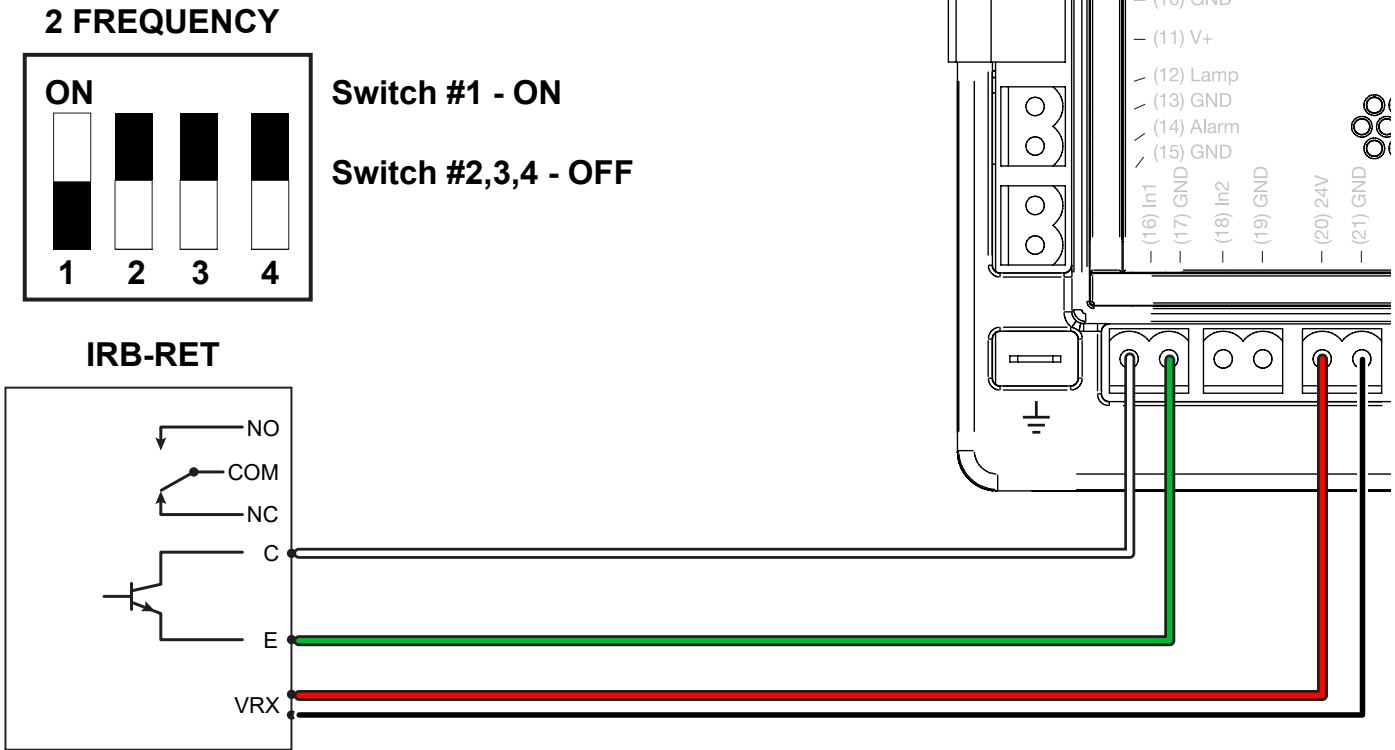

1. Press "Functions"
2. Select #3 "Auxiliary IO" and Press "OK"
3. Select "In Aux 1" (or "In Aux 2") and Press "OK".
4. Select Open Pulse or Close Pulse and "Press OK"
5. Connect 300Hz Monitored Safety Device to In1 (16) or In2 (18) accordingly.

### NOTES:

\*Only one monitored (Pulse) device may be connected per input at In1 or In2.

\*All four (4) jumpers must be on the **LEFT** and **CENTER** pin.

\*At least two monitored devices must be connected properly to 1050 boards that are UL325 7th Edition in order to complete the "Learn" mode. A "BlueBus Error" will result if this requirement is not met.

## 25 - GEM-103 Wiring Diagram

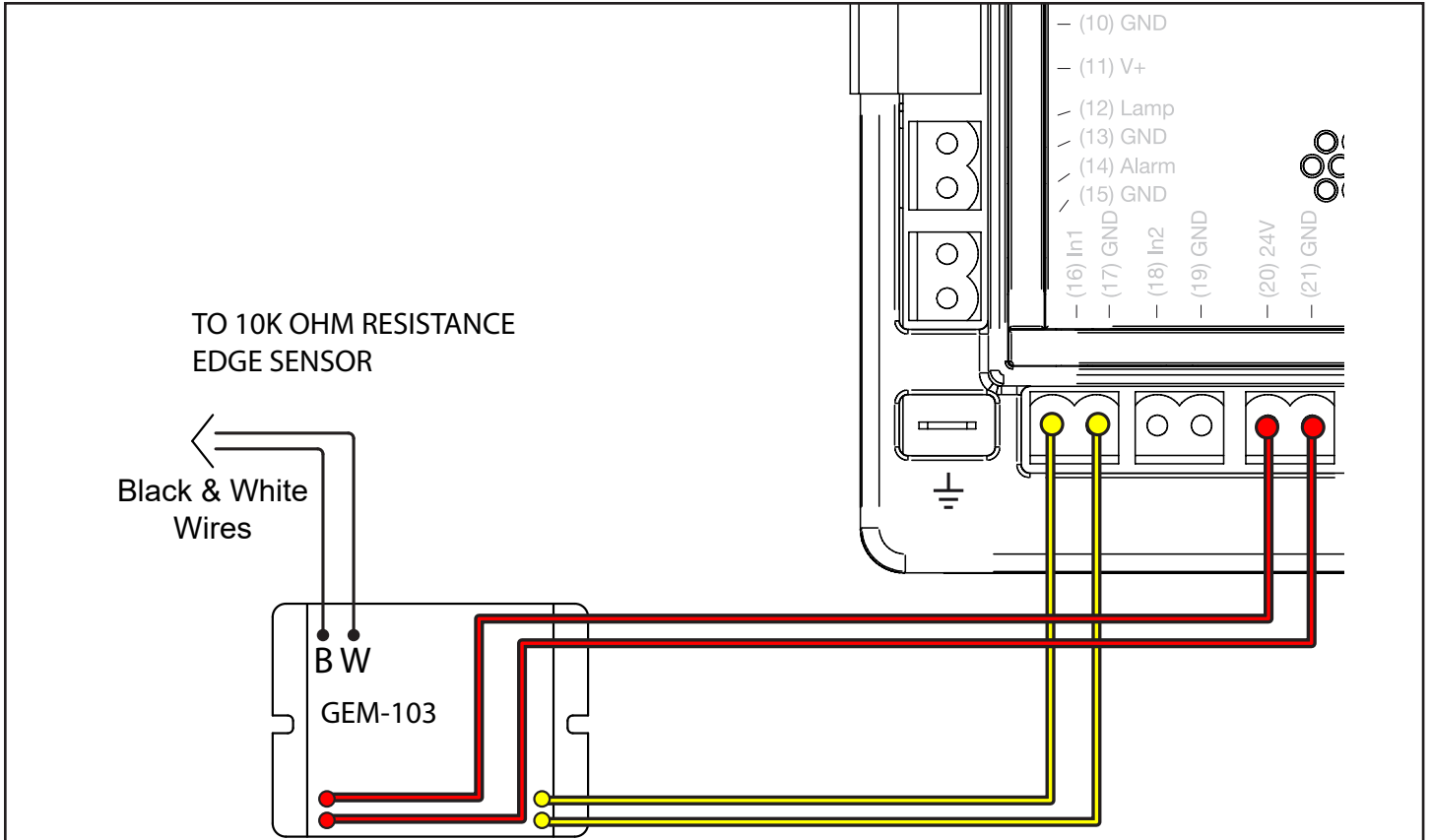

## 26 - WEL-200 Wiring Diagram

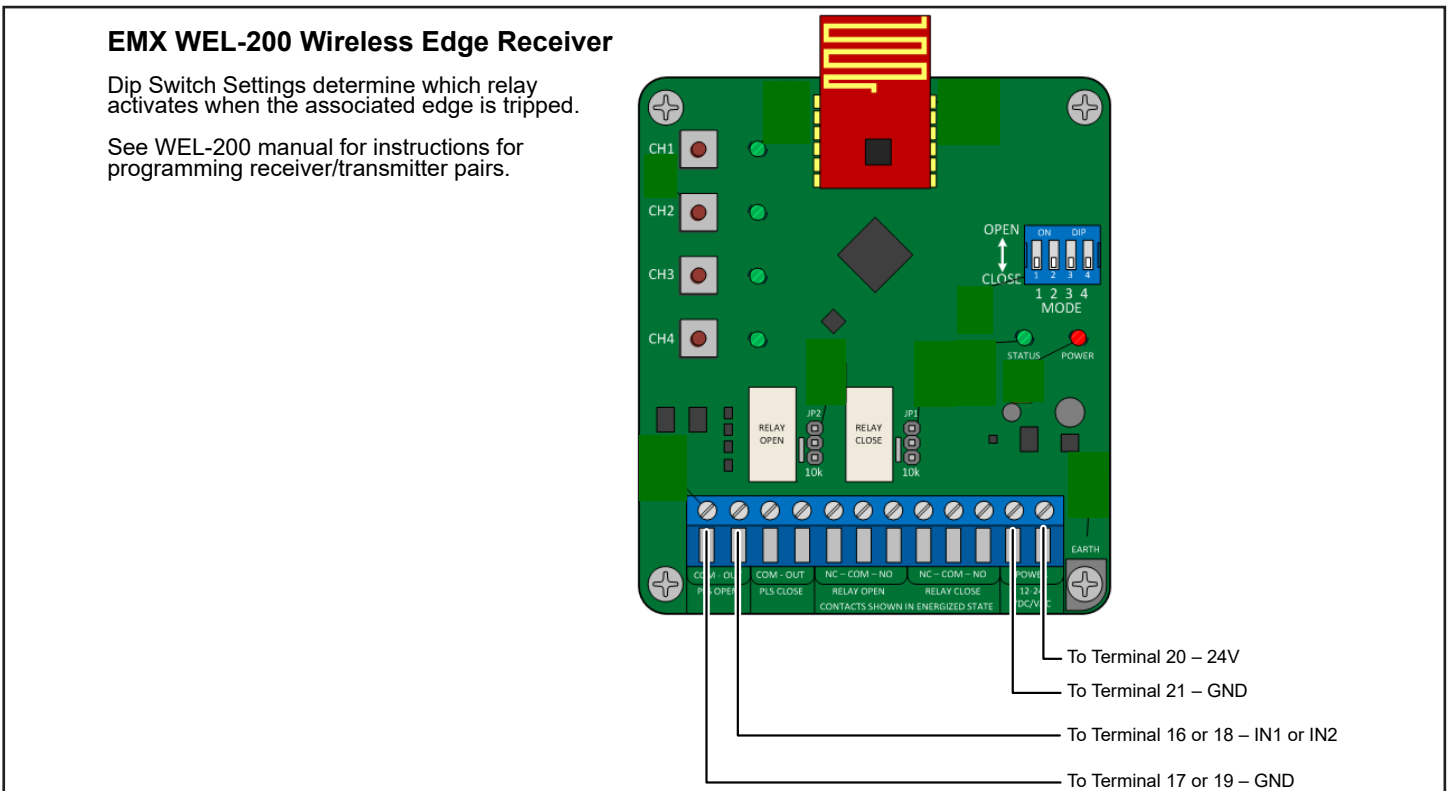

## 27 - BOARD NOMENCLATURE

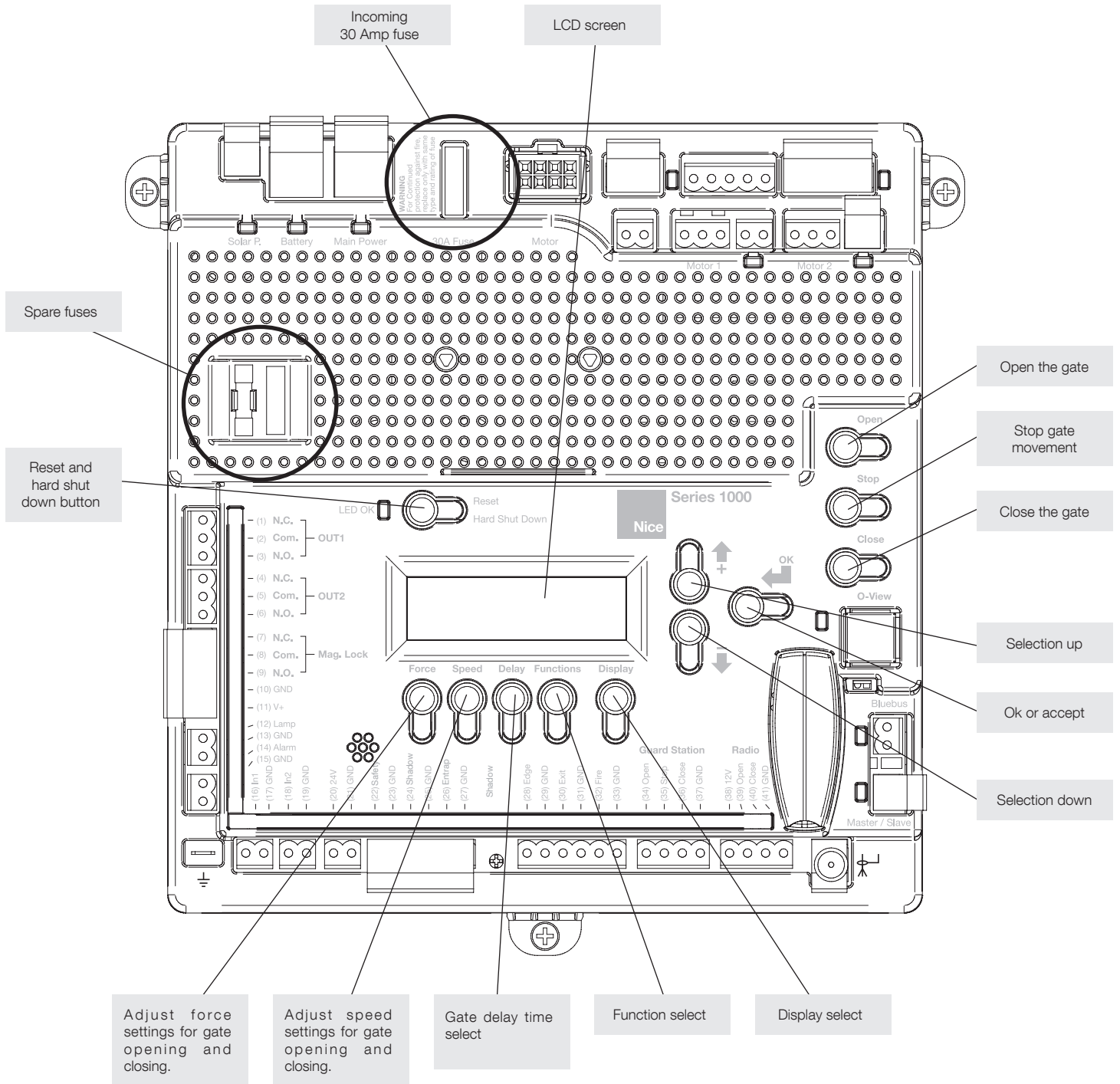

Figure 33 - GENERAL BOARD OVERVIEW

THE PROGRAMMING BUTTONS INDICATED IN THE ABOVE REFERENCE SHOULD BE USED ONLY AFTER UNDERSTANDING THE MANUAL AND ITS RELATION TO THE PROGRAMMING SEQUENCES SHOWN ON THE FOLLOWING PAGES. CARE SHOULD BE TAKEN WHENEVER CHANGES ARE IMPLEMENTED TO ENSURE PROPER FUNCTIONALITY AND SAFETY.

## 28 - PROGRAMMING QUICKSTART

### 28.1 - Learning the gate

1. Install electrical power to the gate opener unit.
2. Install all gate accessories such as Photo-Eye's, Sensors, Loops and other safety devices.
3. Turn on the electrical power to the unit.
4. Using the MANUAL RELEASE HANDLE, disengage the drive motor.
5. Move the gate manually (with your hands) to ensure that the gate travels to the fully open and fully closed positions with no binding or problems. Gate should move freely.
6. Using the MANUAL RELEASE HANDLE, re-engage the drive system and stow the handle.
7. Using the open button on the front of the Control board, hold the button down until the gate reaches the fully open position.
8. Adjust the Open Limit Switch until the GREEN light illuminates on the front of the control board. The FULLY OPEN limit switch is now set.
9. Using the CLOSE button on the front of the Control Board, hold the button down until the gate reaches the fully closed position.
10. Adjust the CLOSED Limit Switch until the RED light illuminates on the front of the control board. The fully CLOSED limit switch is now set.
11. The control board is already in the "LEARNING MODE" when shipped. (If not in LEARNING MODE see section 26.3) Press "OK" to allow the control board to scan for attached items, such as sensors, photo-eye's and other safety devices.
12. The gate will open partially, then stop. This is being done, so that the control board can sense the type and operational condition of the drive motor. The gate will then run to the closing limit, so that it can properly sense where it is located.
13. The control board will then OPEN the gate slowly to establish travel and limits.
14. Once the gate reaches the fully OPENED limit switch, the control board will now increase gate travel speed to the highest speed allotted, and will now travel to the fully CLOSED position at full speed.
15. The gate opener is now programmed for basic usage.

### 28.2 - Gate direction reversal

#### **WARNING: GATE DIRECTION REVERSAL CAN ONLY BE ACCOMPLISHED IN LEARNING MODE**

If for some reason, the installer were to install the opener on the opposite side of the gate from which the unit is programmed, and when you press the "OPEN" button, the gate actually CLOSES, the installer will need to REVERSE the direction of travel to match the buttons on the control board.

Press "OPEN" and note if the gate actually opens. If it does not, and instead is traveling in a CLOSING direction follow the below steps to correct:

1. Press FUNCTION
2. Scroll through the options to reach "ADVANCED SETTINGS"
3. Press ENTER
4. Scroll through selection to reach "DIRECTION OF MOTOR"
5. Press ENTER
6. The direction arrows on the display begin to blink
7. Choose the appropriate direction of travel
8. Press DISPLAY to return to the MAIN MENU
9. Press OPEN to verify that the gate now OPENS

If not in learning mode, follow the below listed steps.

### 28.3 - Putting the controller into learning mode

Steps on how to place the Nice 1050 control board into learning mode.

1. Press Function
2. Press OK
3. Select Slide
4. Select weight of gate
5. Press Enter

Unit should now be in LEARNING MODE

## 29 - PROGRAMMING BUTTONS

### 29.1 - Force

**Static:** Set sensitivity to constant force on a scale of 1 to 10 (1 being the most sensitive).

**Dynamic:** Set sensitivity of sudden impact force to the moving gate on a scale of 1 to 10 (1 being most sensitive).

**ESC:** Exit the FORCE menu.

### 29.2 - Speed

**Max:** Sets the limit of maximum allowed gate speed on a scale of 20% to 100% (20% being the lowest setting).

**Standard:** Sets the limit of the gate speed during normal movement (not soft start/stop) on a scale of 20% to MAX (20% being the lowest setting).

**Low:** Sets the limit of the gate speed while in LEARNING mode and when moving in SLOW, on a scale of 20% to STANDARD (20% being the lowest setting).

**Slowdown:** Set gate speed when going into approaching the open or close limits on a scale of 20% to LOW (20% being the lowest setting).

### 29.3 - Acceleration

**Max:** Sets the limit of gate acceleration when reversing the gate after an obstacle has been detected by the UL/Edge or current sense feature (Force). Settings from 1 to 10, with 10 being the highest rate of gate acceleration. \*

**Standard:** Sets the limit of the gate acceleration in normal operation. Settings from 1 to 10, with 10 being the highest rate of gate acceleration. \*  
\*TO PREVENT DAMAGE TO THE GATE OR THE CONTROLLER USE LOWER ACCELERATION SETTINGS FOR HEAVIER GATES.

**ESC:** Exit the SPEED menu.

### 29.4 - Delay

**Auto Close:** Sets the timeout before the gate closes automatically from the fully open position. Settings from 5 to 120 seconds.

**Slave:** Sets the delay for opening the slave gate leaf in a Master/Slave (Motor 1 and Motor 2 operation), (dual gate) system. Settings from 0 to 5 seconds with a step of 0.5 seconds.

**Lamp/Strobe:** Sets the amount of time the Lamp accessory output is activated prior to gate movement. Settings from 0 to 5 seconds with a step of 0.5 seconds.

**Lock:** Sets the amount of time the Magnetic Lock accessory output is activated to disable the lock when opening the gate. Settings from 0 to 5 seconds with a step of 0.5 seconds.

**Run Time:** Sets the maximum run time for the gate. Used in case the gate doesn't reach its limits. Settings from 5 to 120 seconds with a step of 1 second.

**ESC:** Exit the DELAY menu.



## 29 - PROGRAMMING BUTTONS (CONT.)

### 29.5 - Function

**Learn:** Puts the gate operator into learning mode for a slide or slide gate, and Blue BUS peripherals. Learning mode for a slide style gates involves selecting the gate type (Light, Average, Heavy), then fully opening and closing the gate to sense the limits. Selecting the gate type selects pre-calculated values for the FORCE, SPEED, and ACCELERATION settings. Learning the Blue BUS peripherals enables the gate operator to discover and integrate accessory devices like Blue BUS access control and safety devices.

**Positions:** Configures the points in the gate open, close, and partial cycles at which deceleration occurs.

- Slow Down – Open: Sets the point in the % of gate opening when the gate begins deceleration to the fully open position.
- Slow Down – Close: Sets the % of gate opening when the gate begins deceleration to the fully close position.
- Partial: Sets the point in the % of gate opening when the gate begins deceleration to the Partial open position.

**Auxiliary Inputs:** Auxiliary inputs IN AUX1 (16) and IN AUX2 (18) can be programmed with one of the following options:

- No program No Function used
- OPEN the Gate
- CLOSE the Gate
- STEP Cycling Step (Open-Stop-Close-Stop)
- PARTIAL opening
- PARTIAL 1 Partial Opening 1 (open one leaf in dual gate applications)
- STOP the gate and Auto-closing
- HOLD TO OPEN Input must be maintain active for Opening
- HOLD TO CLOSE Input must be maintain active for Closing
- FIRE Reset Hard Shut Down and Open the Gate
- TIMER 1 Start Count Down TIMER1
- TIMER 2 Start Count Down TIMER2
- PHOTO Photocell PHOTO input: reverse to opening when closing
- PHOTO1 Photocell PHOTO1 input: Stop Gate when activated
- PHOTO2 Photocell PHOTO2 input: reverse to closing when opening
- SHADOW Loop input: prevent closing gate when completely open
- BLOCK system from other command (only STEP H overrides the Block)
- UNBLOCK Un-block the system if blocked
- OPEN and BLOCK Open the Gate and inhibit further commands (except STEP H)
- CLOSE and BLOCK Close the Gate and inhibit further commands (except STEP H)
- OPEN and UNBLOCK Open the Gate and un-inhibit further commands
- CLOSE and UNBLOCK Close the Gate and un-inhibit further commands
- STEP H Command high priority Step cycling (open-stop-close-stop)

**Auxiliary Outputs:** Auxiliary outputs OUT AUX1 (1,2,3,) and OUT AUX2 (4,5,6,) can be programmed with one of the following options:

- NO PROGRAM Output not used
- OPEN Output is activated when Gate is open
- CLOSE Output is activated when Gate is closed
- MOVING Output is activated when Gate is moving
- TIMER 1 Output is activated when TIMER1 is counting down
- TIMER 2 Output is activated when TIMER2 is counting down

**Radio Channel:** For the Plug-in Onboard Receiver, 15 radio channels may be programmed with one of the following options:

- No program
- OPEN (Default CH. 2)
- CLOSE
- STEP (Default CH. 1)
- PARTIAL
- PARTIAL
- STOP
- HOLD TO OPEN
- HOLD TO CLOSE
- FIRE
- TIMER 1
- TIMER 2
- PHOTO
- PHOTO1
- PHOTO2
- SHADOW
- BLOCK
- UNBLOCK
- OPEN and BLOCK
- CLOSE and BLOCK
- OPEN and UNBLOCK
- CLOSE and UNBLOCK
- STEP H

**Timers:** Set time for count down timers Timer 1 and Timer 2. Settings between 1 second and 9 hours in 1 second increments.

**Events:** Up to 8 weekly events (EV1 through EV8) can be programmed and stored. Each event can be programmed to trigger at a specific time and can be assigned to any combination of days of the week (Monday through Sunday). Events that are already programmed into the system may be suspended temporarily, or removed permanently from memory. The following actions can be assigned to events:

- No program
- Open
- Close
- Partial
- Partial1
- AxOut1 On
- AxOut1 Off
- AxOut2 On
- AxOut2 Off
- Block
- Unblock
- Open and Block
- Close and Block
- Open and Unblock
- Close and Unblock

**To program weekly events EV1 through EV8, perform the following steps:**

1. Press FUNCTION -> Events.
2. Press and hold OK to display EV1 (display will blink "EV1").
3. Press UP or DOWN to toggle between events, then press OK to make a selection. The display changes to hours.
4. Press UP or DOWN to toggle between hours, then press OK to make a selection. The display changes to minutes.
5. Press UP or DOWN to toggle between minutes, then press OK to make a selection. The display changes to individual days of the week.
6. Press UP or DOWN to toggle between days of the week. Press OK to toggle between ON and OFF for each day of the week. Continue toggling through the days of the week until ESC is displayed. Press OK to advance to the next event.
7. Repeat step 2 through 6 for event EV2 through EV8.

## 29 - PROGRAMMING BUTTONS (CONT.)

**To temporarily suspend one or more weekly events (EV1 through EV8), perform the following steps:**

1. Press FUNCTION -> Events.
2. Press OK quickly to display EV1 active days.
3. Press OK quickly again to display "Suspend". Event EV1 is now suspended and will not run until re-enabled.
4. Press UP or DOWN to toggle through the events EV1 – EV8 and repeat steps 2 through 3 to suspend or enable other weekly events.

**Charger:** A battery charger is built-in with the Control board for use with a backup battery. The charger may be manually programmed for customized charge settings or set to "Auto" to provide a battery charging profile that automatically compensates for temperature and current during the charging process. The following parameters are available for programming the battery charger:

- Charger On/Off
- Select Max current for charging (from 0.1A to 1.5A step 0.05A)
- Cycling Time (1 second off charging every cycling time)
- Auto (best charge considering temperature)

**Standby:** Programs the timeout for the gate operator to go into low power standby mode. Low power standby is Settings from 5 to 120 seconds, or may be disabled with "OFF". During low power standby there is no data displayed on the gate operator LCD and it consumes a minimum amount of power to extend the life of the backup battery. All the outputs are switched off and the LED OK blinks to show this standby status of the system.

**Advance Settings:** The following settings are available for customizing the gate operator as required by the customer's installation requirements:

- Set Language (English Spanish Italian)
- Set clock 12H/24H
- Set LCD Contrast
- Set Direction Opening (Adapts the motor direction as necessary depending upon the opening direction of the slide or gate)
- Set Virtual Encoder (Used for motors without built-in encoders)
- Set Anti-tailgate (Closes gate immediately after vehicle has cleared safety sensors)
- Select inputs LOOP or PHOTO
- Select UL/EDGE input type (NO, NC, Analog)

**Note:** When set to ANALOG OPEN, CLOSE, or BOTH, this input must have an 8.2k-10k Ohm terminated external entrapment sensor installed. ANALOG BOTH is only available for Swing Gates.

- Select Master / Slave Motor1 or Motor2
- Activate link for remote Master/Slave (Enables control of an additional gate operator board)
- Power Fail Open (Opens gate automatically on batter backup power if main AC power input loss is detected)
- Motor 12V (Forces motor control voltage to +12VDC even if the supply voltage varies from +9.5VDC up to +35VDC)

**Default:** This setting gives the installer/user the option of returning some or all settings of the gate operator to the original factory settings:

- System settings
- Radio Channel settings
- Event settings
- Charger settings

**ESC:** Exit the FUNCTION menu.

## 29.6 - Display

**ESC:** Exit the DISPLAY menu.

**Info:** Displays the manufacturer name, product name/model, software versions, and serial number.

**Clock:** Displays the calendar date and time in the real time clock. Pressing and holding the "OK" button for 5 seconds enables the date and time settings to be updated manually.

**Main Volt:** Displays the gate operator main control voltage in volts DC.

**Battery Volt:** Displays the gate operator backup battery voltage in volts DC.

**Sun Volt:** Displays the solar panel input voltage in volts DC.

**Motor Volt:** Displays the voltage at the motor in volts DC.

**UL Volt:** Displays the voltage at the UL/Edge sensor input in volts DC.

**Temperature:** Displays the temperature of the gate controller board in degrees Centigrade or Fahrenheit (press OK and hold 5 seconds to change scale).

**Service:** The following information is recorded and viewable about the operating history of the gate:

- Total: Displays the total number of open-close cycles (non- Settings ).
- Partial: Display the total number of partial cycles. Reset by pressing the "OK" button for several seconds.
- Maint. Display the number of cycles before service is required. Settings from 1000 to 50000 cycles in increments of 1000 cycles.

**Motor:** Displays the Motor position, voltage, and current.

**Motor 1:** Displays the Motor1 position, voltage, and current.

**Motor 2:** Displays the Motor2 position, voltage, and current.

**Charger:** Displays the battery charger voltage and current.

**Last Reset:** Displays the code for diagnostic review. Used for diagnostic and troubleshooting.

**ESC:** Exit the DISPLAY menu.

## 30 - EMERGENCY VEHICLE ACCESS

- 30.1** The automatic vehicular gate system must be designed to allow access to emergency vehicles under different operating conditions.
- 30.2** During normal powered operation, emergency vehicles access the gate by use of the emergency vehicle access device installed on your gate system. The type of device that is used in your community is dependent on your city codes. These devices may include (but are not limited to) Fire Department lock boxes, Click-2-Enter radio receivers, strobe light sensors, siren sensors, etc.
- 30.3** Check with your installer to determine if your gate system is equipped with a back-up power system. In the event of a primary (AC) power failure and a back-up system (DC) power failure (low charged or dead batteries for example), the system must have a release system to allow the gate to be manually operated.
- 30.4** This operator is equipped with a manual release system that will allow the gate to be pushed open in the event of a power outage or equipment failure.
- 30.5** **NOTE:** Never attempt to manually push open any gate with an operator attached to it until you have verified that power to the operator has been shut-off.
- 30.6** The automatic vehicular gate system must be designed to allow access to emergency vehicles under different operating conditions.
- 30.7** In the event of a power failure, the emergency vehicle access device may not be functional because the gate operator is un-powered. **NOTE:** DC powered back-up systems are optional and your gate system may or may not be equipped with one. Check with your installer to determine if your gate system is equipped with a back-up power system.
- 30.8** The FAIL-SAFE manual operation system is the most reliable and safest method for placing an automated gate in manual operation and is the preferred method of emergency gate operation under worse case conditions by many Fire Chiefs and Building Inspectors and is typically used in CLASS I and CLASS II applications.
- 30.9** For manual fail-safe gate operation, turn power to the operator OFF. If a backup power system is in use, be sure that this power is turned OFF also. Once power is OFF, the gate can be manually operated, by using the MANUAL RELEASE handle under the top cover.

## 31 - GLOSSARY

- BLOCK** - Ceases all operator function except HIGH PRIORITY inputs.
- COMMERCIAL / GENERAL ACCESS VEHICULAR GATE OPERATOR-CLASS II** - A vehicular gate operator (or system) intended for use in a commercial location or building such as a multi-family housing unit (five or more single family units), hotels, garages, retail store, or other building servicing the general public.
- ENTRAPMENT** - The condition when an object is caught or held in a position that increases the risk of injury.
- FORCE STATIC** - Constant load threshold for sensitivity setting.
- FORCE DYNAMIC** - Impact sensitivity setting.
- GATE** - A moving barrier such as a swinging, sliding, raising, lowering, or the like, barrier, that is a stand-alone passage barrier or is that portion of a wall or fence system that controls entrance and/or egress by persons or vehicles and completes the perimeter of a defined area.
- (STEP H) HIGH PRIORITY** - Step by step control
- INHERENT ENTRAPMENT SENSOR SYSTEM** - An automatic sensor system which senses entrapment of a solid object and is incorporated as a permanent and integral part of the operator.
- INDUSTRIAL / LIMITED ACCESS VEHICULAR GATE OPERATOR-CLASS III** - A vehicular gate operator (or system) intended for use in an industrial location or building such as a factory or loading dock area or other locations not intended to service the general public
- RESTRICTED ACCESS VEHICULAR GATE OPERATOR-CLASS IV** - A vehicular gate operator (or system) intended for use in a guarded industrial location or building such as an airport security area or other restricted access locations not servicing the general public, in which unauthorized access is prevented via supervision by security personnel.
- RESIDENTIAL VEHICULAR GATE OPERATOR-CLASS I** - A vehicular gate operator (or system) intended for use in a home of one-to four single family dwelling, or garage or parking area associated therewith.
- STEP BY STEP** - Command that opens-stops-closes-stops the gate with each press of the button.
- SYSTEM** - In the context of these requirements, a system refers to a group of interacting devices intended to perform a common function.
- UNBLOCK** - Resumes normal operation after a blocked condition.
- WIRED CONTROL** - A control implemented in a form of fixed physical interconnections between the control, the associated devices, and an operator to perform predetermined functions in response to input signals.
- WIRELESS CONTROL** - A control implemented in means other than fixed physical interconnections (such as radio waves or infrared beams) between the control, the associated devices, and an operator to perform predetermined functions in response to input signals.

## 32 - MAINTENANCE SCHEDULE - NICE GATE OPENER

Table 2

		COMPLETE	BASIC
Alarm	Active the primary (inherent)reverse system by blocking the gate with a solid object. The gate should reverse momentarily then stop. Restart the gate and block again with a solid object. The gate should reverse momentarily, then stop, and go into hard shutdown with an alarm	●	●
Backup System	If operator is equipped with option DC backup system, check to be sure the system opens the gate upon loss of AC power	●	●
Battery	If operator is equipped with option DC backup system, check the batteries for any leakage or loose connections. Batteries should be replaced every two years	●	
Drive Chain	Check for alignment, tightness and wear	●	
Fire Dept	Check emergency vehicle access device for proper operation	●	●
Gate	Inspect for damage. Check gate rollers for wear and grease if necessary	●	
Chain lube	Main Sprocket and chain	●	
Reverse System	Check that the gate reverses on contact with an object in both the opening and closing cycles	●	●
Loop(s)	Check vehicular reverse and shadow loops for proper operation	●	●
Release	Check manual release for proper operation	●	
Complete	Overall Check: Complete check of gate and gate operating system	●	
Mounting Hardware	Check screws and nuts	●	
Rain Drain	Remove top lid and sweep out any debris or dust that may have accumulated. Every 6 months.	●	

## 33 - NICE GATE OPENER TROUBLESHOOTING

Table 3

SYMPTOM(S)	POSSIBLE SOLUTION
Operator will not Power On. Power LED is OFF	Check that power to the operator is turned ON Check terminal block wiring for loose or broken wires Check for 115 VAC at source. If voltage measures OK, check the terminal block Check the fuse
Gate opens a short distance, then stops and reverses	Check the UL/Edge input on the gate controller Adjust Force Settings
Gate opens but will not close	Check the input LEDs. Any ON will hold the gate open and indicates a problem with a keying device Check the secondary safety devices. Any activated safety device will hold the gate open and indicates a problem with the safety device Check the loop detectors. Any activated safety device can hold the gate open and indicates a problem with the loop detector or ground loop
Battery backup system will not open gate upon AC power outage	Check if backup system is set to open gate automatically or requires an input to open Check the batteries for proper voltage. Replace if necessary
Hard Shutdown (2 back to back obstructions) LED blinking, Buzzer sounds for 5 minutes	Clear any obstructions from the path of the gate. Press RESET to clear (or hard reset button)
Gate opens by itself	Check accessory inputs and clear them as necessary

### 33 - NICE GATE OPENER TROUBLESHOOTING (CONT.)

**Table 4: 1050 Board Display Read Out and Troubleshooting**

DISPLAY	REASON	POSSIBLE SOLUTION
Dynamic M1	Actuated connected to Motor 1 has a brief current spike and tripped Type A sensor.	Check for obstruction in gate path or degraded gate hardware.
Dynamic M2	Actuated connected to Motor 2 has a brief current spike and tripped Type A sensor.	Check for obstruction in gate path or degraded gate hardware.
Static M1	Actuated connected to Motor 1 has an extended current spike and tripped Type A sensor.	Check for obstruction in gate path or degraded gate hardware.
Static M2	Actuated connected to Motor 2 has an extended current spike and tripped Type A sensor.	Check for obstruction in gate path or degraded gate hardware.
Input UL/Edge	UL/Edge input is tripped while gate is running. Appears is IN1 or IN2 input is tripped if configured as a pulsed, external sensor input.	Ensure photo eyes are aligned, edges are not tripped, and all inputs are programmed correctly.
Input STOP!	STOP input is not connect to GND.	Ensure jumper wire is being used and check external stop button wiring.
Photo Test FAIL!	BlueBus monitored sensor check fails.	Verify photo eye is connected, aligned, and internal jumpers are set correctly.
Device Error	Position sensor is not being correctly detected by the board or if there is an active input on the board preventing the learn process.	Ensure Motor 1 and Motor 2 position sensors are connected correctly for the type of actuator being used. Also make sure there are no active inputs.
Gate Opened	Appears during Learn Mode if Open Limit is active.	Change gate to mid-travel and restart the learn process.
BlueBus or Input - Activated	Appears when active BlueBus or other external entrapment sensor input is preventing gate motion.	Ensure all sensors are connected correctly and properly aligned. Ensure all inputs are programmed correctly.
Hard Shut Down	Appears when Dynamic and/or Static sensors have two consecutive trips.	Press the Reset/Hard Shut Down button to clear the trip and reenable gate operation.
Overload	Appears when Motor 1 or Motor 2 over-current.	Ensure motors are connected properly and there is no obstruction to gate movement.
Slide Requires - Min 2 Sensors	Appears when there are not at least two external entrapment sensors programmed and installed on a Slide Gate: 1. Open direction 2. Close direction.	Ensure all sensors are connected correctly and functional. Does not appear on Swing gates.
1 Open & 1 CIs - Sensor Required	Appears when Slide Gate operator does not at have at least one external entrapment sensor programmed and installed in each direction.	Ensure all sensors are connected correctly and functional. Does not appear on Swing gates.
Min. 1 Sensor - For Swing Gate!	Appears when Swing gate operator does not have at least one entrapment sensor programmed and installed for both open and close direction for travel.	Install minimum number of sensors. Does not appear on Slide Gates
BlueBus Error!	Appears when previously learned numbers and type of BlueBus sensors change.	Correct wiring/number of sensors and redo the learn procedure for the operator.
Scanning BluBus - Prs Disp to Cncl	Appears when initial BlueBus learn procedure is in process.	Pressing the Display button will postpone the scan and remain in Learn Mode. Pressing and holding the open or close buttons will move the gate in the desired direction.

## LIMITED WARRANTY—NICE-BRANDED PRODUCTS

### 1. Warranty.

HySecurity Gate, Inc. (“HySecurity”) warrants that at the time of sale, each Nice-branded gate operator product that it sells will, in all material respects, conform to the then applicable specification for the product and will be free from defects in material and manufacture.

The following additional durational warranties apply to products purchased through a distributor authorized by HySecurity to sell Nice products (“Authorized Distributor”), depending on whether (1) the product is purchased through an Authorized Distributor and (2) whether a timely and complete product registration is submitted to HySecurity.

*It is therefore important that you register your product with HySecurity, online at [www.hysecurity.com/warranty](http://www.hysecurity.com/warranty), within the 60-day period described below.*

#### 1(a) Nice-branded Products Purchased Through Authorized Distributors and Properly Registered

For any gate operator product that is purchased from an Authorized Distributor (this excludes product purchased through internet resellers or any distributor not authorized by HySecurity to sell Nice products), if the product registration is completed by the Dealer/Installer or End User within 60 days of the date of purchase, the following warranty terms will apply. HySecurity warrants that the product will remain serviceable for the following periods:

- a) Electromechanical pad-mounted Slide and Swing operators: Two Years after the date of installation,
- b) Electromechanical linear actuator Swing operators: Two Years after the date of installation,
- c) Electromechanical barrier arm operators: Two years after the date of installation,
- d) Nice-branded accessories: Two years after the date of installation, *provided that* the Two Year warranty period in (a), (b), or (c) will not extend beyond four years from the date that the product was shipped from HySecurity.

The preceding warranty durations do not apply to the products or components described below (e-f), which have a shorter warranty period:

- e) Batteries: One Year from date of shipment from HySecurity.
- f) Components subject to normal wear including, but not limited to, chains, belts, idler wheels, sprockets and fuses: One Year from date of installation.

#### 1(b) Nice Products Not Purchased Through an Authorized Distributor or Not Properly Registered within 60 Days

For any product that is not purchased from an Authorized Distributor or for which the product registration was not completed by the Dealer/Installer/End User within sixty (60) days of the date of purchase, the following **One-Year Limited Warranty** will apply: HySecurity warrants that the product will remain serviceable for One Year from the date that the product was shipped from HySecurity.

#### 1(c) Replacement Parts

HySecurity warrants that replacement parts (whether new or reconditioned) will remain serviceable for One Year from the date that the part was shipped from HySecurity or the remaining period of the Gate Operator warranty, whichever is longer.

#### 1(d) Limitations and Exclusions Applicable to Each of the Preceding Warranties.

The preceding warranties shall not apply to equipment that has been (1) installed, maintained, or used improperly or contrary to instructions; (2) subjected to negligence, accident, vandalism, or damaged by severe weather, wind, flood, fire, terrorism or war; or (3) damaged through improper operation, maintenance, storage or abnormal or extraordinary use or abuse. Any modification made to products will void the warranty unless the modifications are approved in writing by HySecurity in advance of the change (this exclusion does not apply to normal installation of approved accessories and/or protective devices or sensors). It is the responsibility of the Distributor, Dealer/Installer, or End User to ensure that the software version in the product is maintained to the latest revision level.

The preceding warranties do not extend to accessories when those items carry the name plate of a manufacturer other than HySecurity or Nice and they are not a part of the base model. HySecurity disclaims all warranties for such accessory components, which carry only the original warranty, if any, of their original manufacturer. HySecurity hereby assigns its rights under such manufacturer warranties—to the extent that such rights are assignable—to Buyer.

These warranties extend to HySecurity’s Distributors, to the Dealer/Installer, and to the first End User of the product following installation. They do not extend to subsequent purchasers.

### 2. Limitation of Certain Implied Warranties and Exclusion of Other Warranties.

The warranties contained in Section 1 are the exclusive express warranties given by HySecurity and supersede any previous, contrary or additional representations, whether oral or written. Any prior or extrinsic representations or agreements are discharged or nullified. ANY IMPLIED WARRANTIES, INCLUDING ANY **WARRANTY OF MERCHANTABILITY OR WARRANTY OF FITNESS FOR A PARTICULAR PURPOSE**, ARE LIMITED IN DURATION TO PERIOD OF THE APPLICABLE EXPRESS WARRANTY FOR THE PRODUCT OR COMPONENT. HYSECURITY HEREBY DISCLAIMS AND EXCLUDES ALL OTHER WARRANTIES—INCLUDING ANY LIABILITY FOR INFRINGEMENT, AND ANY WARRANTIES OTHERWISE ARISING FROM COURSE OF DEALING, COURSE OF PERFORMANCE, OR USAGE OF TRADE.

Some states do not allow limitations on how long an implied warranty lasts, so the above limitation may not apply to you.

### 3. Buyer’s Exclusive Remedies for Any Nonconformity.

If a Nice product fails to conform to the warranties in Section 1, Buyer must notify and order replacement parts from the Distributor through which the product was purchased within a reasonable time and in no event more than thirty (30) days after the discovery of the nonconformity. HySecurity will investigate and, in the event of a breach, will provide, within a reasonable period of time, one of the following: (1) repair or replacement of any nonconforming products or components or (2) refund of the price upon return of the nonconforming items. HySecurity reserves the right to supply used or reconditioned material for all warranty claims. HySecurity will not be considered to be in breach of or default under this Warranty because of any failure to perform due to conditions beyond its reasonable control, including any force majeure. This warranty does not cover any incidental expenses, including fines or penalties, temporary security, labor, shipping, travel time or standby time that are incurred for inspection or replacement of any nonconforming items. As a condition of warranty coverage, warranty claims must be submitted in accordance with the procedures described on the HySecurity form, “RMA Procedures.”

THE REMEDY SELECTED BY HYSECURITY IN ACCORDANCE WITH THIS PARAGRAPH SHALL BE THE **EXCLUSIVE AND SOLE REMEDY OF BUYER FOR ANY BREACH OF WARRANTY.**

### 4. Exclusion of Consequential and Incidental Damages.

HYSECURITY AND NICE SHALL NOT BE LIABLE FOR ANY INCIDENTAL, SPECIAL, OR CONSEQUENTIAL DAMAGES, WHETHER RESULTING FROM NONDELIVERY OR FROM THE USE, MISUSE, OR INABILITY TO USE THE PRODUCT OR FROM DEFECTS IN THE PRODUCT OR FROM HYSECURITY’S OR NICE’S OWN NEGLIGENCE. This exclusion applies regardless of whether such damages are sought for breach of warranty, breach of contract, negligence, or strict liability. This exclusion does not apply to claims for bodily injury or death.

Some states do not allow the exclusion or limitation of incidental or consequential damages, so the above limitation may not apply to you.

### 5. Severability.

If any provision of this warranty is found to be invalid or unenforceable, then the remainder shall have full force and effect.

### 6. Proprietary Rights.

HySecurity and Nice retain and reserve all right, title, and interest in the intellectual property rights of their products, including any accompanying proprietary software. No ownership of any intellectual property rights in the products or accompanying software is transferred to Distributor, Dealer/Installer, or End User.

### 7. Applicable Law.

This warranty will be interpreted, construed, and enforced in all respects in accordance with the laws of the State of Washington, without reference to its choice of law principles. The U.N. Convention on Contracts for the International Sale of Goods will not apply to this warranty.

This warranty gives you specific legal rights, and you may also have other rights which vary from State to State.

## 35 - INSTALLATION CHECKLIST

**Left box is for installer check off and the right box is for customer check off.**

- 1. The gate has been checked to make sure it is level and moves freely in both directions.
- 2. Potential pinch areas have been guarded so as to be inaccessible OR have contact and/or non-contact obstruction sensing devices installed.
- 3. The installer has installed one or more contact or non-contact obstruction sensing devices, in compliance with UL325 requirements for this installation.
- 4. If pedestrian traffic is expected, a separate pedestrian gate has been installed, a minimum of seven feet from the gate. The customer has been informed that all pedestrian traffic must use the pedestrian gate.
- 5. Warning signs have been installed on each side of the gate in highly visible locations. The customer has been informed that these signs must remain at all times.
- 6. There are no controls installed on the gate operator, or within 8 feet of the gate.
- 7. The installer has properly adjusted the obstruction sensing feature and has tested the gate to make sure that the gate stops and reverses a short distance with minimal resistance applied (Approximately 75 lbs. on a slide gate).
- 8. The installer has instructed the customer in the proper use of the gate operator and reviewed all of the operational functions, obstruction sensing devices, warning beeper and reset, etc.
- 9. The installer has instructed the customer in the proper use of the operator's manual disconnect feature. The manual disconnect must never be used while the gate is in motion. The power switch must be turned off before using the manual disconnect and disengaging the operator.
- 10. The installer has reviewed all safety instructions with the customer, and has left the safety instructions and owner's information sheets for their reference.
- 11. The installer has answered any questions the customer has regarding the operation of the gate operator and gate operator safety precautions.
- 12. The installer has explained to the customer that a regular maintenance schedule for both the gate and the gate operator is recommended.

---

Installation Acceptance

---

Address where opener is located

---

Installer name, number and address

---

End user name and telephone number

**Contact us**

Nice  
6705 S. 209th St., Suite 101  
Kent, WA 98032-2327  
Ph. +1.253.867.3700  
Fax +1.253.867.3702

[www.hysecurity.com](http://www.hysecurity.com)  
[www.facebook.com/hsgateoperators](https://www.facebook.com/hsgateoperators)

