



HySecurity®

Industrial

Gate Operators

Gate automation and
traffic control solutions catalog



All gate installations must comply with UL325 and ASTM F2200 safety standards in addition to any local area codes and standards. Site, gate hardware, usage class, and other conditions will dictate the use of additional safety designs and components.

All safety related warnings and notices in this document, and any diagrams, drawings, photographs and similar content should not be considered guidance on how to make your particular site safe and code compliant. It is the responsibility of the gate system designer, installer and owner to assess appropriate safety design considerations, correct implementation and ongoing maintenance of any system.

This informational Product Catalog is distributed on an "as is" basis, without warranty. Every precaution has been taken in preparation of the entirety of the book. Neither the authors nor the publisher shall have any liability to any person or entity with respect to any loss or damage caused or alleged to be caused directly or indirectly by the information contained in this book.

©2024 Nice North America LLC. All rights reserved. This book may not be reproduced in whole or in part, in any way, shape, or form, by electronic or mechanical means, including information storage and retrieval systems without written permission from Nice HySecurity Gate, Inc., except in the case of an active, authorized Nice | HySecurity Reseller copying drawings, operator or part descriptions, and order forms exclusively for Nice | HySecurity product sales purposes.

Industrial Gate Operators Catalog

Contents

StrongArm®	8	StrongArm Diagrams	45
SlideDriver™ II.....	16	SlideDriver II Diagrams	50
HydraSwing™	24	HydraSwing Diagrams	54
SwingRiser™	30	SwingRiser Diagrams.....	58
AC Power Supply with HyInverter™ AC	37	AC and DC Power Supply Diagrams.....	63
DC Power Supply with HyCharger™	39		

All specifications are subject to change without notice. PDF available online at hysecurity.com or contact your distributor.
partners.hysecurity.com/extranet/

Warranty: hysecurity.com/warranty



Why Nice?

Nice is a worldwide recognized industry leader of automated gate and perimeter security solutions.

The Nice brand features residential and commercial gate operators, from elegant linear actuators to refined swing gate operators.

The HySecurity brand provides high-quality, ultra-reliable industrial gate operators and crash-rated, Hostile Vehicle Mitigation (HVM) vehicle barriers designed to secure and protect critical infrastructure and facilities.

Industrial Gate Operators Product Catalog



View the latest parts diagrams from anywhere.

- Quick search results by operator
- Easy to find part diagrams and part numbers
- Always updated
- Available digitally anywhere, anytime
- Download and print materials, as needed

SlideDriver™ II

SlideDriver II

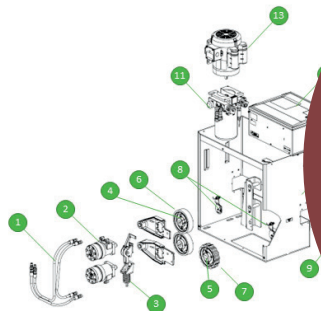

This drawing is a representation and should be used for parts reference only.

NO	PART NUMBER	DESCRIPTION	SD15	SD40	SD60V
1	MX0523	Hose Kit, 1/8 inch w/ID, 3 lengths	x	x	x
2	MX4752	Motor, Hydraulic, 10 inch	x	x	x
	MX4849	Motor, Hydraulic, 24 inch			x
3	MX001103	Release, Manual, Toggle Assy	x	x	x
4	MX002707	6 inch diameter AdvanceDrive Wheel, hub, lug nuts, and mounting hardware.	x	x	
	MX3132	8 inch AdvanceDrive wheel kit, including hub, lug nuts, and mounting hardware.			x
	MX3449	6 inch diameter XtremeDrive wheel kit, including hub, lug nuts, and attachment hardware	x	x	
5	MX3550	8 inch XtremeDrive wheel kit, including hub, lug nuts, and attachment hardware.			x
	MX4994	Wheel Kit, Replacement, 6 inch	x	x	
	MX3223	Wheel Kit, Replacement, 8 inch			x
7	MX3449	XtremeDrive Wheel, 6 inch	x	x	x
	MX3352	XtremeDrive Wheel, 8 inch			x
8	MX4933	Limit Sensor Assy	x	x	x
	MX4982	Limit Kit, Stop Indicator	x	x	x
9	MX4991	Limit Kit, SlideDriver II SDOF			x
10	MX3330X	Chassis, Replacement, SlideDriver II	x	x	x
	MX4989	Pump Pack, SlideDriver II, SD15	x		
	MX5535	Pump Pack, SlideDriver II SD 40		x	
	MX5536	Pump Pack, SlideDriver II SDOF, SD60V			x
12	MX5504	Cover, Electrical Enclosure	x	x	x
13		Motor, Electric			See parts list

Parts Diagrams are located at the back of this book as an addendum. Diagrams and support material can also be found on the Nice | HySecurity Support Center. <https://support.hysecurity.com>

Nice | HySecurity Support Center

Submit support request Sign In

Q: Apollo

Swing Gate / Apollo 816

- Brochures and Spec Sheets, Operator: [Apollo Linear Actuator Spec Sheet](#)
- Manuals, Operator: [Apollo 1500 Linear Actuator System \(816 arm & 636 Control Board\) Installation Reference Manual](#)
Changed DIP Switch illustration on page 37 to show Dip Switch 1 as OFF (not ON) to ...
- [Apollo 816 Linear Actuator Installation Reference Manual](#)
How to install the Apollo 816 linear actuator without a system
- [Apollo 816 Linear Actuator 120 Degree Install Instructions](#)
How to install the Apollo linear actuator at a 120 Degree angle

Part: [Apollo 816 Linear Actuator Part Diagrams](#)

Swing Gate Vertical Lift

Can't find what you're looking for?
Contact the Nice | HySecurity Technical Support Team.

253-201-2918 Submit support request Email Support Email Sales

Nice | HySecurity Support Center Back to Our Main Site Nice | HySecurity



Traffic Control

StrongArm®	8
StrongArm Technical Specifications.....	9
StrongArm Model.....	10
StrongArm Installed Options	11
StrongArm Parts and Accessories.....	13

StrongArm®

Reliable, low-maintenance multi-lane traffic control. The preferred solution for traffic control, proven through decades of reliable service.



Very long arms from 10 - 36 ft StrongArm 36 raises a 36 ft arm in just 8 seconds. Ideal for airports, ferry terminals and other multi-lane applications.

Secure uni-body welded chassis constructed with rigid 10 gauge sheet metal.

Side mount for arms up to 20 feet, center mount yoke with counterweights for arms 20-36 ft



Reach: Raise barrier arms up to 36 ft long for broad vehicle access points.



Fast: Raise arm in as little as 2 seconds (depending on length) to keep traffic flowing.



Clearance: Rotates 90° to fully open arms up to 28 ft., allowing tall vehicles free access.



Safe: Available breakaway arm mount stops gate, protecting pedestrians, vehicles, and equipment.



Programmable: Configurable to specific site requirements.



Application: Easy primary/secondary controls with HySecurity gate operators.



Models: DOT model with standard galvanized steel chassis and breakaway arm bracket.



Visible: 14F features available lighted arm for enhanced visibility in low light conditions.



Tough: Secure steel chassis and tamper resistant cover.



Made in USA: Designed, tested, and built within USA from globally sourced materials.



StrongArm Technical Specifications

Model	StrongArm 14F	StrongArm 14F UPS	StrongArm 20	StrongArm 20 UPS	StrongArm 28	StrongArm 28 UPS	StrongArm DOT 28	StrongArm DOT 28 UPS	StrongArm 36	StrongArm 36 UPS
Arm Length Max.	Up to 14 ft (4.3 m)		Up to 20 - 28 ft (6 - 8.5m)* Side mount available for arms up to 18 ft (5.5 m)				Up to 28 ft (8.5 m)		Up to 36 ft (11 m)*	
Arm Design	Side mount. Lighted aluminum arm with HyProtect™ breakaway arm bracket and kill switch, up to 14 ft (4.3 m)		Side mount - aluminum up to 18 ft (5.5 m), fiberglass up to 16 ft (5 m) or wood up to 14 ft (4.3 m). Center yoke mount - aluminum up to 20 ft (6 m)		Center yoke mount. Aluminum up to 24 ft (7 m), fiberglass up to 16 ft (5 m), or aluminum-fiberglass 26+ ft (8+ m)*		Center yoke. Breakaway arm bracket. Aluminum arms up to 24 ft (7 m) or aluminum-fiberglass arms 26 and 28 ft (8 and 8.5 m) ***		Center yoke mount. Aluminum-fiberglass up to 36 ft (11 m)**	
Full Open Angle	90°									
Duty Cycle	2,000 cycles/day*									
Horsepower	3/4 hp									
Drive	Hydraulic									
Open/Close Time	2 seconds to open; 3 seconds to close		3 seconds to open; 4 seconds to close		5 seconds to open; 6 seconds to close				8 seconds to open; 8 seconds to close	
Handing	Left or right		Left, right or center yoke		Center yoke					
UPS Battery Backup Cycles****	StrongArm 14F UPS or optional 230V AC Power Supply w/ HyInverter AC™ **	DC Power Supply w/HyCharger DC™ provides up to 300 cycles after an AC power loss.*	StrongArm 20 UPS or optional 230V AC Power Supply w/ HyInverter AC™	DC Power Supply w/HyCharger DC™ provides up to 300 cycles after an AC power loss.*	StrongArm 28 UPS or optional 230V AC Power Supply w/ HyInverter AC™	DC Power Supply w/HyCharger DC™ provides up to 300 cycles after an AC power loss.*	StrongArmDOT 28 UPS or optional 230V AC Power Supply w/HyInverter AC™	DC Power Supply w/HyCharger DC™ provides up to 300 cycles after an AC power loss.	StrongArm 36 UPS or optional 230V AC Power Supply w/ HyInverter AC™	DC Power Supply w/HyCharger DC™ provides up to 300 cycles after an AC power loss.*
Temperature Rating	-40° to 158° F (-40° to 70° C)									
Single Phase Voltages	115/208/230V 60Hz, 110/220 50Hz*									
Three Phase Voltages	220/380V 50Hz†, 208/230/460V 60Hz	N/A	220/380V 50Hz†, 208/230/460V 60Hz	N/A	220/380V 50Hz†, 208/230/460V 60Hz	N/A	220/380V 50Hz†, 208/230/460V 60Hz	N/A	220/380V 50Hz†, 208/230/460V 60Hz	N/A
Communication	RS-232, RS-485									
User Controls	Smart Touch Controller with 70+ configurable settings. Smart Touch keypad and 32 character, OLED display or a PC using S.T.A.R.T. software.									
Relays	Three configurable user relays: one 30VDC, 3A solid state and two 250VAC, 10A electromechanical. Optional Hy8Relay™ for 8 additional relay outputs.									
Enclosure	N/A	DC Power Supply: Type 3R, 30w x 30h x 12d inch (76w x 76h x 30.5d cm)	N/A	DC Power Supply: Type 3R, 30w x 30h x 12d inch (76w x 76h x 30.5d cm)	N/A	DC Power Supply: Type 3R, 30w x 30h x 12d inch (76w x 76h x 30.5d cm)	N/A	DC Power Supply: Type 3R, 30w x 30h x 12d inch (76w x 76h x 30.5d cm)	N/A	DC Power Supply: Type 3R, 30w x 30h x 12d inch (76w x 76h x 30.5d cm)
Finish	Zinc plated with yellow powder coating						Hot dipped galvanized with stainless steel cover		Zinc plated with yellow powder coating	
ETL Listed (UL 325)	Usage Class I, II, III, IV									
Warranty	5 year									

* The operator's normal duty cycle and the actual number of arm cycles available from battery depends upon arm length/weight, battery size, state of charge and health, ambient temperature, accessory power draw and frequency of arm cycles during power outage. ** Arms 20 ft (6 m) or longer require counterweights.

*** Arms 30 ft (9 m) or longer require cable tensioner and arm stabilizer kit and additional counterweights

**** AC operators require High Inverter; DC operators require DC Power Supply w/HyCharger DC.

† Refer to Installed Options on pricing for all 50Hz voltages, which are special order.

†† 115V DC Power Supply requires a 30A branch circuit. Choose voltage with care as chargers are not field convertible.

StrongArm Model

Solution	Component	Component Name	Part Numbers	Weight	Dimensions	Freight Class
StrongArm 14F	StrongArm 14F	HTG 320-2 ST	S-HTG-1-50	335 lb	38"w x 30"d x 54"h	70
StrongArm 14F UPS	StrongArm 14F DC DC Power Supply	HTG 320-2 DC ST DCPS-60	S-HTG-1-60 S-DCP-1-C0	335 lb 335 lb	38"w x 30"d x 54"h 38"w x 30"d x 54"h	70 70
StrongArm 20	StrongArm 20	HTG 320-3 ST	S-HTG-51	335 lb	38"w x 30"d x 54"h	70
StrongArm 20 UPS	StrongArm 20 DC DC Power Supply	HTG 320-3 DC ST DCPS-60	S-HTG-1-61 S-DCP-1-C0	335 lb 335 lb	38"w x 30"d x 54"h 38"w x 30"d x 54"h	70 70
StrongArm 28	StrongArm 28	HTG 320-6 ST	S-HTG-1-53	335 lb	38"w x 30"d x 54"h	70
StrongArm 28 UPS	StrongArm 28 UPS DC Power Supply	HTG 320-6 DC ST DCPS-60	S-HTG-1-63 S-DCP-1-C0	335 lb 335 lb	38"w x 30"d x 54"h 38"w x 30"d x 54"h	70 70
StrongArm DOT 28	StrongArmDOT	HTG 320-6 DOT ST	S-HTG-1-54	335 lb	38"w x 30"d x 54"h	70
StrongArm DOT 28 UPS	StrongArm 28 DC DC Power Supply	HTG 320-6 DC DOT ST DCPS-60	S-HTG-1-65 S-DCP-1-C0	464 lb 335 lb	38"w x 30"d x 54"h 38"w x 30"d x 54"h	70 70
StrongArm 36	StrongArm 36	HTG 320-8 ST	S-HTG-1-53	600 lb	38"w x 30"d x 54"h	70
StrongArm 36 UPS	StrongArm 36 UPS DC Power Supply	HTG 320-8 DC ST DCPS-60	S-HTG-1-63 S-DCP-1-C0	600 lb 335 lb	38"w x 30"d x 54"h 39"w x 28"d x 39"h	60 70



The HySecurity DC Power Supply can be paired with DC power models of StrongArm to provide uninterruptible power. The UPS provides up to 300 cycles after an AC power loss. For more information see the DC Power Supply section of this catalog.

For AC powered operators, the AC Power Supply with HyInverter AC Provides UPS battery backup for 208-230VAC single-phase barrier arms, providing up to 300 cycles after an AC power loss. For more information see the DC Power Supply section of this catalog.



The actual number of gate cycles available from battery depends upon the operator's duty cycle, battery size, state of charge, age, ambient temperature, accessory power draw and frequency of gate cycles during power outage.



Barrier arm and arm mounting bracket prices are not included in StrongArm base prices. See "StrongArm Options" for arm configurations and arm assembly.

StrongArm Installed Options

Name	Part Number	Description	Shipping dimensions	Estimated shipping weight	Add on weight
Arm, Aluminum, Oval w/Kill Switch, 10 ft	S-HTG-5-40	10 ft oval aluminum oval arm for operators with kill switch built after June 2017. Includes LED light strip with UV stabilized cover and bumper.	7"w x 144"d x 9"h	17 lb	13 lb
Arm, Aluminum, Oval w/Kill Switch, 12 ft	S-HTG-5-42	12 ft oval aluminum oval arm for operators with kill switch built after June 2017. Includes LED light strip with UV stabilized cover and bumper.	7"w x 168"d x 9"h	21 lb	13 lb
Arm, Aluminum, Oval w/Kill Switch, 14 ft	S-HTG-5-44	14 ft oval aluminum oval arm for operators with kill switch built after June 2017. Includes LED light strip with UV stabilized cover and bumper.	7"w x 192"d x 9"h	24 lb	13 lb
Arm, DOT Mount, Aluminum, 10 ft	S-HTG-5-71	Barrier arm with breakaway bracket and 2 counterweights, aluminum, 2 x 5 inch - 10 ft length (requires StrongArm 28).	7"w x 144"d x 9"h	12 lb	318 lb
Arm, DOT Mount, Aluminum, 12 ft	S-HTG-5-73	Barrier arm with breakaway bracket and 2 counterweights, aluminum, 2 x 5 inch - 12 ft length (requires StrongArm 28)	7"w x 168"d x 9"h	21 lb	318 lb
Arm, DOT Mount, Aluminum, 14 ft	S-HTG-5-75	Barrier arm with breakaway bracket and 2 counterweights, aluminum, 2 x 5 inch - 14 ft length (requires StrongArm 28)	7"w x 192"d x 9"h	24 lb	318 lb
Arm, DOT Mount, Aluminum, 16 ft	S-HTG-5-77	Barrier arm with breakaway bracket and 2 counterweights, aluminum, 2 x 5 inch - 16 ft length (requires StrongArm 28)	7"w x 216"d x 9"h	27 lb	370 lb
Arm, DOT Mount, Aluminum, 18 ft	S-HTG-5-79	Barrier arm with breakaway bracket and 2 counterweights, aluminum, 2 x 5 inch - 18 ft length (requires StrongArm 28)	7"w x 240"d x 9"h	31 lb	370 lb
Arm, DOT Mount, Aluminum, 20 ft	S-HTG-5-81	Barrier arm with breakaway bracket and 4 counterweights, aluminum, 2 x 5 inch - 20 ft length (requires StrongArm 28)	7"w x 264"d x 9"h	34 lb	370 lb
Arm, DOT Mount, Aluminum, 22 ft	S-HTG-5-83	Barrier arm with breakaway bracket and 6 counterweights, aluminum, 2 x 5 inch - 22 ft length (requires StrongArm 28)	7"w x 288"d x 9"h	38 lb	422 lb
Arm, DOT Mount, Aluminum, 24 ft	S-HTG-5-85	Barrier arm with breakaway bracket and 8 counterweights, aluminum, 2 x 5 inch - 24 ft length (requires StrongArm 28)	7"w x 312"d x 9"h	41 lb	422 lb
Arm, DOT Mount, Aluminum/Fiberglass, 26 ft	S-HTG-5-88	Barrier arm with breakaway bracket and 12 counterweights, aluminum, 2 x 5 inch - 26 ft length (requires StrongArm 28)	7"w x 312"d x 9"h	46 lb	474 lb
Arm, DOT Mount, Aluminum/Fiberglass, 28 ft	S-HTG-5-89	Barrier arm with breakaway bracket and 14 counterweights, aluminum, 2 x 5 inch - 28 ft length (requires StrongArm 28)	7"w x 312"d x 9"h	48 lb	474 lb
Arm, Side Mount, Aluminum, 10 ft	S-HTG-5-01	Barrier arm with side mount bracket and clamps, aluminum, 2 x 5 - 10 ft length (StrongArm 20, 28, 36)	7"w x 144"d x 9"h	17 lb	13 lb
Arm, Side Mount, Aluminum, 12 ft	S-HTG-5-02	Barrier arm with side mount bracket and clamps, aluminum, 2 x 5 inch - 12 ft length (StrongArm 20, 28, 36).	7"w x 168"d x 9"h	20 lb	13 lb
Arm, Side Mount, Aluminum, 14 ft	S-HTG-5-03	Barrier arm with side mount bracket and clamps, aluminum, 2 x 5 inch - 14 ft length (StrongArm 20, 28, 36).	7"w x 192"d x 9"h	24 lb	13 lb
Arm, Side Mount, Aluminum, 16 ft	S-HTG-5-04	Barrier arm with side mount bracket and clamps, aluminum, 2 x 5 inch - 16 ft length (requires StrongArm 20 or larger).	7"w x 216"d x 9"h	27 lb	13 lb
Arm, Side Mount, Aluminum, 18 ft	S-HTG-5-05	Barrier arm with side mount bracket and clamps, aluminum, 2 x 5 inch - 18 ft length (requires StrongArm 20 or larger).	7"w x 240"d x 9"h	31 lb	13 lb
Arm, Side Mount, Fiberglass, 10 ft	S-HTG-5-06	Barrier arm with side mount bracket and clamps, fiberglass, 1-3/4 x 4-3/4 inch - 10 ft length (StrongArm 20, 28, 36).	7"w x 144"d x 9"h	12 lb	13 lb
Arm, Side Mount, Fiberglass, 12 ft	S-HTG-5-07	Barrier arm with side mount bracket and clamps, fiberglass, 1-3/4 x 4-3/4 inch - 12 ft length (StrongArm 20, 28, 36).	7"w x 168"d x 9"h	14 lb	13 lb
Arm, Side Mount, Fiberglass, 14 ft	S-HTG-5-08	Barrier arm with side mount bracket and clamps, fiberglass, 1-3/4 x 4-3/4 inch - 14 ft length (StrongArm 20, 28, 36).	7"w x 192"d x 9"h	17 lb	13 lb
Arm, Side Mount, Fiberglass, 16 ft	S-HTG-5-09	Barrier arm with side mount bracket and clamps, fiberglass, 1-3/4 x 4-3/4 inch - 16 ft length (requires StrongArm 20 or larger).	7"w x 216"d x 9"h	19 lb	13 lb
Arm, Yoke Mount, Aluminum, 10 ft	S-HTG-5-15	Barrier arm with center yoke mount and bracket, aluminum, 2 x 5 inch - 10 ft length (StrongArm 20, 28, 36).	7"w x 144"d x 9"h	17 lb	104 lb
Arm, Yoke Mount, Aluminum, 12 ft	S-HTG-5-16	Barrier arm with center yoke mount and bracket, aluminum, 2 x 5 inch - 12 ft length (StrongArm 20, 28, 36).	7"w x 168"d x 9"h	20 lb	104 lb
Arm, Yoke Mount, Aluminum, 14 ft	S-HTG-5-17	Barrier arm with center yoke mount and bracket, aluminum, 2 x 5 inch - 14 ft length (StrongArm 20, 28, 36).	7"w x 192"d x 9"h	24 lb	104 lb
Arm, Yoke Mount, Aluminum, 16 ft	S-HTG-5-18	Barrier arm with center yoke mount and bracket, aluminum, 2 x 5 inch - 16 ft length (requires StrongArm 20 or larger).	7"w x 216"d x 9"h	27 lb	104 lb
Arm, Yoke Mount, Aluminum, 18 ft	S-HTG-5-19	Barrier arm with center yoke mount and bracket, aluminum, 2 x 5 inch - 18 ft length (requires StrongArm 20 or larger).	7"w x 240"d x 9"h	31 lb	104 lb
Arm, Yoke Mount, Aluminum, 20 ft	S-HTG-5-20	Barrier arm with center yoke mount, bracket and 2 counterweights, aluminum, 2 x 5 inch - 20 ft length (requires StrongArm 20 or larger).	7"w x 264"d x 9"h	34 lb	154 lb
Arm, Yoke Mount, Aluminum, 22 ft	S-HTG-5-21	Barrier arm with center yoke mount, bracket and 4 counterweights, aluminum, 2 x 5 inch - 22 ft length (requires StrongArm 28 or 36).	7"w x 288"d x 9"h	37 lb	204 lb
Arm, Yoke Mount, Aluminum, 24 ft	S-HTG-5-22	Barrier arm with center yoke mount, bracket and 6 counterweights, aluminum, 2 x 5 inch - 24 ft length (requires StrongArm 28 or 36).	7"w x 312"d x 9"h	41 lb	254 lb

StrongArm Installed Options

Name	Part Number	Description	Shipping dimensions	Estimated shipping weight	Add on weight
Arm, Yoke Mount, Aluminum/Fiberglass, 26 ft	S-HTG-5-23	Barrier arm with center yoke mount, bracket and 10 counterweights, aluminum/fiberglass, 26 ft length (requires StrongArm 28 or 36).	7"w x 312"d x 9"h	48 lb	354 lb
Arm, Yoke Mount, Aluminum/Fiberglass, 28 ft	S-HTG-5-24	Barrier arm with center yoke mount, bracket and 12 counterweights, aluminum/fiberglass, 28 ft length (requires StrongArm 28 or 36).	7"w x 312"d x 9"h	48 lb	404 lb
Arm, Yoke Mount, Aluminum/Fiberglass, 30 ft	S-HTG-5-25	Barrier arm with center yoke mount, bracket and 16 counterweights, aluminum/fiberglass, 30 ft length. Includes cable tensioner and arm stabilizer kit. (requires StrongArm 36).	7"w x 312"d x 9"h	50 lb	533 lb
Arm, Yoke Mount, Aluminum/Fiberglass, 32 ft	S-HTG-5-26	Barrier arm with center yoke mount, bracket and 18 counterweights, aluminum/fiberglass, 32 ft length. Includes cable tensioner and arm stabilizer kit. (requires StrongArm 36).	7"w x 312"d x 9"h	54 lb	583 lb
Arm, Yoke Mount, Aluminum/Fiberglass, 34 ft	S-HTG-5-27	Barrier arm with center yoke mount, bracket and 22 counterweights, aluminum/fiberglass, 34 ft length. Includes cable tensioner and arm stabilizer kit. (requires StrongArm 36).	7"w x 312"d x 9"h	55 lb	683 lb
Arm, Yoke Mount, Aluminum/Fiberglass, 36 ft	S-HTG-5-28	Barrier arm with center yoke mount, bracket and 24 counterweights, aluminum/fiberglass, 36 ft length. Includes cable tensioner and arm stabilizer kit. (requires StrongArm 36).	7"w x 312"d x 9"h	58 lb	733 lb
Arm, Yoke Mount, Fiberglass, 10 ft	S-HTG-5-29	Barrier arm with center yoke mount and bracket, fiberglass, 1-3/4 x 4-3/4 inch - 10 ft length (StrongArm 20, 28, 36).	7"w x 144"d x 9"h	12 lb	104 lb
Arm, Yoke Mount, Fiberglass, 12 ft	S-HTG-5-30	Barrier arm with center yoke mount and bracket, fiberglass, 1-3/4 x 4-3/4 inch - 12 ft length (StrongArm 20, 28, 36).	7"w x 168"d x 9"h	14 lb	104 lb
Arm, Yoke Mount, Fiberglass, 14 ft	S-HTG-5-31	Barrier arm with center yoke mount and bracket, fiberglass, 1-3/4 x 4-3/4 inch - 14 ft length (StrongArm 20, 28, 36).	7"w x 192"d x 9"h	17 lb	104 lb
Arm, Yoke Mount, Fiberglass, 16 ft	S-HTG-5-32	Barrier arm with center yoke mount and bracket, fiberglass, 1-3/4" x 4-3/4 inch - 16 ft length (requires StrongArm 20 or larger).	7"w x 216"d x 9"h	19 lb	104 lb
Buzzer Option	S-HTG-7-01	Piezo alarm buzzer. Buzzer comes standard on StrongArm 36			
Chassis, Galvanized with Stainless Steel Cover	S-HTG-4-02	Chassis, hot dipped galvanized option for use in highly corrosive environments, often in Department of Transportation applications. Chassis is unpainted hot dipped galvanized and cover is unpainted stainless steel.			
Color, Custom, StrongArm	S-HTG-4-01	Custom color chassis and cover. Zinc plated steel, prime painted with ultra-durable, textured finish coat. Passes a 1,000 hour salt spray test and exhibits excellent abrasion resistance. Contact factory for colors available.			
Crate, Export Shipping, DC Power Supply	DC-B-01	Certified heat treated wood crate for export shipping, DC Power Supply			
Crate, Export Shipping, StrongArm	S-HTG-B-01	Certified heat treated wood crate for export shipping, StrongArm.			
Flashing Light Kit, StrongArm	S-HTG-8-05	Includes 1 light, order MX001197 for extra lights, max 4.			
Heater, 115VAC, StrongArm	S-HTG-6-00	115VAC Heater and thermostat.			
Heater, 230VAC, StrongArm	S-HTG-6-01	230VAC Heater and thermostat.			
Heater, 460VAC, StrongArm	S-HTG-6-02	460VAC Heater and thermostat.			
Motor, Electric, 50Hz, StrongArm	S-HTG-2-80	50Hz motor option. Longer lead time may apply.			
Radio Receiver, Single Channel, Open, StrongArm	S-HTG-9-00	Single channel receiver and coax antenna, wired for open control only.			

StrongArm Parts and Accessories

Name	Part Number	Description
Arm Assembly, Aluminum, Oval, 10 ft	MX4182-10	10 ft oval aluminum oval arm for operators with kill switch built after June 2017. Includes LED light strip with UV stabilized cover and bumper. StrongArmPark DC, WedgeSmart DC and StrongArm 14F operators.
Arm Assembly, Aluminum, Oval, 12 ft	MX4182-12	12 ft oval aluminum oval arm for operators with kill switch built after June 2017. Includes LED light strip with UV stabilized cover and bumper. StrongArmPark DC and StrongArm 14F operators.
Arm Assembly, Aluminum, Oval, 14 ft	MX4182-14	14 ft oval aluminum oval arm for operators with kill switch built after June 2017. Includes LED light strip with UV stabilized cover and bumper. StrongArmPark DC and StrongArm 14F operators.
Arm Sleeve, StrongArmDOT 28	MX3346	Arm sleeve for StrongArmDOT 28.
Arm, Replacement, Aluminum, Rectangular, 10 ft	MX001001	2 x 5 inch rectangular aluminum arm replacement, 10 ft length Note: Arm only. Mounting hardware not included.
Arm, Replacement, Aluminum, Rectangular, 12 ft	MX001002	2 x 5 inch rectangular aluminum arm replacement, 12 ft length Note: Arm only. Mounting hardware not included.
Arm, Replacement, Aluminum, Rectangular, 14 ft	MX001003	2 x 5 inch rectangular aluminum arm replacement, 14 ft length Note: Arm only. Mounting hardware not included.
Arm, Replacement, Aluminum, Rectangular, 16 ft	MX001004	2 x 5 inch rectangular aluminum arm replacement, 16 ft length Note: Arm only. Mounting hardware not included.
Arm, Replacement, Aluminum, Rectangular, 18 ft	MX001005	2 x 5 inch rectangular aluminum arm replacement, 18 ft length Note: Arm only. Mounting hardware not included.
Arm, Replacement, Aluminum, Rectangular, 20 ft	MX001006	2 x 5 inch rectangular aluminum arm replacement, 20 ft length Note: Arm only. Mounting hardware and 2 counterweights not included.
Arm, Replacement, Aluminum, Rectangular, 22 ft	MX001007	2 x 5 inch rectangular aluminum arm replacement, 22 ft length Note: Arm only. Mounting hardware and 4 counterweights not included.
Arm, Replacement, Aluminum, Rectangular, 24 ft	MX001008	2 x 5 inch rectangular aluminum arm replacement, 24 ft length Note: Arm only. Mounting hardware and 6 counterweights not included.
Arm, Replacement, Aluminum/Fiberglass, 26 ft	MX000742	Rectangular aluminum/fiberglass arm replacement, 26 ft length Note: Arm only. Mounting hardware and 10 counterweights not included. Additional counterweights are required if extra materials are attached to the arm
Arm, Replacement, Aluminum/Fiberglass, 28 ft	MX000743	Rectangular aluminum/fiberglass arm replacement, 28 ft length Note: Arm only. Mounting hardware and 12 counterweights not included. Additional counterweights are required if extra materials are attached to the arm.
Arm, Replacement, Aluminum/Fiberglass, 30 ft	MX000744	Rectangular aluminum/fiberglass arm replacement, 30 ft length Note: Arm only. Mounting hardware and 16 counterweights not included. Additional counterweights are required if extra materials are attached to the arm.
Arm, Replacement, Aluminum/Fiberglass, 32 ft	MX000745	Rectangular aluminum/fiberglass arm replacement, 32 ft length Note: Arm only. Mounting hardware and 18 counterweights not included. Additional counterweights are required if extra materials are attached to the arm..
Arm, Replacement, Aluminum/Fiberglass, 34 ft	MX000746	Rectangular aluminum/fiberglass arm replacement, 34 ft length Note: Arm only. Mounting hardware and 22 counterweights not included. Additional counterweights are required if extra materials are attached to the arm.
Arm, Replacement, Aluminum/Fiberglass, 36 ft	MX000747	Rectangular aluminum/fiberglass arm replacement, 36 ft length Note: Arm only. Mounting hardware and 24 counterweights not included. Additional counterweights are required if extra materials are attached to the arm.
Arm, Replacement, Fiberglass, 8 ft	MX001037	Arm section, fiberglass, 1.75 x 4.75 inch - 8 ft length Note: Arm only. Mounting hardware not included.
Arm, Replacement, Fiberglass, 10 ft	MX001038	Arm section, fiberglass, 1.75 x 4.75 inch - 10 ft length Note: Arm only. Mounting hardware not included.
Arm, Replacement, Fiberglass, 12 ft	MX001039	Arm section, fiberglass, 1.75 x 4.75 inch - 12 ft length Note: Arm only. Mounting hardware not included.
Arm, Replacement, Fiberglass, 14 ft	MX001040	Arm section, fiberglass, 1.75 x 4.75 inch - 14 ft length Note: Arm only. Mounting hardware not included.
Arm, Replacement, Fiberglass, 16 ft	MX001041	Arm section, fiberglass, 1.75 x 4.75 inch - 16 ft length Note: Arm only. Mounting hardware not included.
Cable, Smart Touch Controller	MX4138	Download cable with USB to RS-232 adapter, 6 ft, connects laptop to Smart Touch Controller, use with Smart Touch Analyze and Retrieve Tool (S.T.A.R.T.)
Counterweight Mount, Left	MX000641	StrongArm left counterweight mount.
Counterweight Mount, Right	MX000642	StrongArm right counterweight mount.
Counterweight, Barrier Arm	MX000566	Counterweight, pre-punched and zinc plated for corrosion resistance. (Counterweight size is 10 x 18 x 0.5 inch, steel plate weighs 25 lb)

StrongArm Parts and Accessories

Name	Part Number	Description
Counterweight, Barrier Arm, Breakaway	MX3267	Counterweight for Breakaway option only, pre-punched and hot-dipped galvanized for corrosion resistance. (Counterweight size is 10 x 18 x 0.5 inch, steel plate weighs 25 lb) StrongArmDOT 28.
Coupler, Motor, 5/8 inch Shaft, 9T, Old	MX001650	Electric motor-to-pump coupler, 5/8 inch x 9T spline, hydraulic operators manufactured before 6/1/2009 Note: Includes motor shaft key, single use packet of Loctite® to re-assemble the motor coupling set screw and single use packet of Loctite® Anti-Seize to re-assemble the motor coupling to the pump shaft.
Detector, Vehicle, Hy5B™ 2.0	MX4621	Improved loop detector module with digital interface to SmartCNX and all other HySecurity controllers. Automatically sets sensitivity. Automatically compensates for gate movement. Advanced loop diagnostics
Heater Kit, 115VAC	MX001109	Heater kit with thermostat, 115VAC for StrongArm, SwingRiser.
Heater Kit, 230VAC	MX001110	Heater kit with thermostat, 208-230VAC for StrongArm, SwingRiser, HydraLift, HydraSwing, HydraWedge.
Heater Kit, 460VAC	MX001193	Heater kit with thermostat, 460VAC, includes relay contactor, for StrongArm.
Heater Thermostat	MX001875	Thermostat for heater, on at 40° F, includes bracket.
Heater, 115VAC (Strip Only)	MX000910	115VAC heater (strip only).
Heater, 230VAC (Strip Only)	MX000911	230VAC heater (strip only).
Heater, 460VAC (Strip Only)	MX000912	460VAC heater (strip only).
Heater, DC Power Supply, 115VAC	MX3311-01	115VAC DC Power Supply Heater.
Heater, DC Power Supply, 208-230VAC	MX3311-02	208-230VAC DC Power Supply Heater.
Light Kit, Flashing, Additional	MX001197	Kit includes additional flashing light to attach to MX3426, 4 inch diameter lens, mounting hardware and wiring Note: Limit four flashing lights per barrier arm.
Light Kit, Flashing, Base	MX3426	LED Flashing light kit for arm, 4 inch diameter lens, 24VDC (Includes one light).
Lights, Flexible, 10 ft	MX4124-10	Red LED light strand for 10 ft aluminum oval barrier arm. StrongArmPark DC, WedgeSmart DC and StrongArm 14F. Note: Also used for 9 ft WedgeSmart DC arm (cut extra and epoxy seal end)
Lights, Flexible, 12 ft	MX4124-12	Red LED light strand for 12 ft aluminum oval barrier arm. StrongArmPark DC and StrongArm 14F.
Lights, Flexible, 14 ft	MX4124-14	Red LED light strand for 14 ft aluminum oval barrier arm. StrongArm Park DK and StrongArm 14F.
Noise Isolator	MX001162	Open/Close/Stop noise/lightning isolator (long distance module).
Paint Pen, Yellow	MX001319	Touch up paint pen for StrongArm Yellow chassis and cover, 0.5 fl oz.
Photo Eye Kit, Reflective, 40 ft, 24VDC	MX000999	Reflective photo eye kit, 40 ft range, AC or 24VDC, includes reflector, mounting bracket and hardware.
Photo Eye, Through Beam, 65 ft	MX5972-01	Through beam photo eye with integrated hood. Includes mounting hardware.
Push Button Station, 2 Button	MX001180	Push button station, 2 button, open/close (NEMA 1).
Push Button Station, 3 Button	MX001174	Push button control station, 3 button, open/close/stop (NEMA 1).
Receiver, Remote, Antenna and Coax Cable	MX001179	Antenna and coax cable for single and dual channel receiver.
Receiver, Remote, Single Channel	MX001181	Linear Multicode™ receiver, 1 channel, 300MHz, includes antenna and 3 ft cable.
Relay Module, Hy8Relay™, Smart Touch	MX3307-02	Extended Hy8Relay module provides 8 additional programmable relay outputs for Smart Touch operators.
Transmitter, Remote, 1 Button	MCS308911	Linear Multi-Code one button transmitter, 300MHz.
Transmitter, Remote, 2 Button	MCS412001	Linear Multi-Code two button transmitter, 300MHz.

Slide Gate Operator

Engineered with **NEW**
SmartTouch725



SlideDriver™ II.....	16
SlideDriver II Technical Specifications	17
SlideDriver II Models	18
SlideDriver II Installed Options.....	19
SlideDriver II Parts and Accessories	21

SlideDriver™ II

Maximum security combined with extreme durability.

The most secure slide gate operator with power to move any gate, customizable for every unique application.

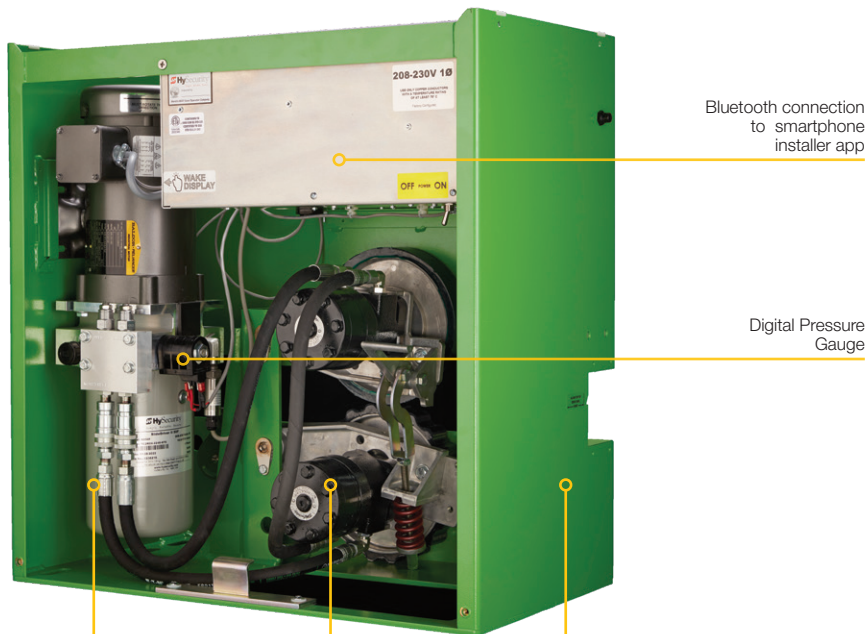

Bluetooth connection to smartphone installer app

Digital Pressure Gauge

Extremely reliable hydraulics.

Optional XtremeDrive™ cogged drive wheels

Secure uni-body welded chassis
Constructed with rigid 12 gauge sheet metal and protected with ultra durable polyester powder coat over zinc plating for an enduring attractive finish.



Powerful: Move gates up to 20,000 lb.



Tough: Secure steel chassis and tamper resistant cover.



Reliable: UPS models remain functional during a power outage.



Smart: Integrated primary/secondary controls and preprogrammed relay settings.



Programmable: Configurable to specific site requirements.



All weather performance: Reliable operation within a wide temperature range.



Durable: Decades long life and low maintenance.



Made in USA: Designed, tested, and built within USA from globally sourced materials.



SlideDriver II Technical Specifications

Model	SlideDriver II SD15	SlideDriver II SD40	SlideDriver II SD50F	SlideDriver II SD80V	SlideDriver II SD200V
Duty Cycle	Continuous				
Horsepower	1 hp	1 hp; DC Option 2 hp	2 hp	5 hp; DC Option 4 hp	
Drive	Hydraulic		Hydraulic with VFD motor control		
Drive Wheels	Two 6 inch (15 cm) AdvanceDrive wheels		Two 8 inch (20 cm) AdvanceDrive wheels	One 8 inch (20 cm) AdvanceDrive wheel, One 8 inch XtremeDrive wheel and 27 ft (8 m) of rack	Two 8 inch (20 cm) AdvanceDrive wheels, Two 8 inch XtremeDrive wheels and 52 ft (16 m) of rack
Rate of Travel	1 ft/s (30 cm/s)		Field adjustable, 2.2 ft/s (70 cm/s) or 3 ft/s (91 cm/s). Emergency Fast Operate 3 ft/s (91 cm/s)	Field adjustable, .75 ft/s (23 cm/s) or 1 ft/s (30 cm/s).	
Gate Length Max.	Limited only by weight				
Gate Weight Max.	Up to 1,500 lb (680 kg)	Up to 4,000 lb (1,814 kg)	Up to 5,000 lb (2,268 kg)	Up to 8,000 lb (3,629 kg)	Up to 20,000 lb (9,072 kg)
Pull Force	300 lb (136 kg)			600 lb (272 kg)	1,200 lb (544 kg)
UPS Battery Backup Cycles*	Optional 230V AC Power Supply w/ HyInverter AC™	Select option S-SD2-2-2J for DC configuration. Requires DC Power Supply DCPS-60, purchased separately.	Optional 230V AC Power Supply w/HyInverter AC™		Select option S-SD2-2-2T for DC configuration. Requires DC Power Supply DCPS-150 ordered separately.**
Temperature Rating	-40° to 158° F (-40° to 70° C)				
Single Phase Voltages	115/208-230V 60 Hz, 110/220V 50 Hz***		208-230V 60Hz, 220V 50Hz***		N/A
Three Phase Voltages	208-230/460V 60Hz, 220/380/440V 50Hz***				
Included Accessories	One premium EMX IRB-MON photo eye, one 5-foot premium ASO edge sensor				N/A
Communication	BlueBUS, USB, Ethernet, RS-485, Bluetooth, OXI receiver. SmartTouch 720 available without Ethernet or Bluetooth for sensitive installations.				
User Controls	SmartTouch 725 Controller with 70+ configurable settings. 32 character OLED display and 7 tactile buttons, or Bluetooth smartphone interface, for programming. SmartTouch 720 Available without Bluetooth or Ethernet.				
Relays	8 Configurable relays: Two 250V 20A electromechanical relays and six 30VDC 2A solid state relays		Three configurable user relays: Two 30VDC 2A solid state, one 240VAC, 20A electromechanical. Optional I/O Expansion module for 8 additional relay outputs.		
Enclosure	N/A				
Finish	Zinc based undercoat with powder coating				
ETL Listed (UL 325)	Usage Class I, II, III, IV		Usage Class III, IV		
Warranty	5 year w/product registration				

*The actual number of gate cycles available from battery power depends upon gate resistance to travel, cycle length, battery size, state of charge and health, ambient temperature, accessory power draw and frequency of gate cycles during power outage.

**SlideDriver II SD200 UPS has a 2,000 ft/hr (610 m/hr) expected duty cycle. Actual duty cycle depends on site specific conditions and gate configuration.

***Refer to Installed Options on pricing for all 50Hz voltages, which are special order.

SlideDriver II Models

Solution	Models	Part Numbers	Weight	Dimensions	Freight Class
SlideDriver II SD15	SlideDriver II 15	SD15	258 lb	26"w x 30"d x 35"h	70
SlideDriver II SD40	SlideDriver II 40	SD40	260 lb	26"w x 30"d x 35"h	70
SlideDriver II SD50F	SlideDriver II 50F	SD50F	276 lb	26"w x 30"d x 35"h	70
SlideDriver II SD80V	SlideDriver II 80V	SD80V	291 lb	26"w x 30"d x 35"h	70
SlideDriver II SD200V	SlideDriver II 200V	SD200V	418 lb	40"w x 32"d x 38"h	70



UPS Backup Power Solutions: For SD40 and SD200, order the DC Power installed option and DC Power Supply with HyCharger DC (See "DC Power Supply with Installed Options" on page 41).
For SD15, SD50F and SD80V, order the AC model and AC Power Supply with HyInverter AC (See "DC Power Supply with Installed Options" on page 41).
Both AC and DC solutions provide standby power and up to 3,000 feet of gate travel after AC line power is interrupted.



Included Sensors: All models except SD200V include one premium EMX IRB-MON photo eye and one 5-foot premium ASO edge sensor.



Correctional Facility Upgrade: To configure a gate operators for correctional or other high security application, select the corrections cover installation option. Operators with this option are manufactured with heavy guage steel chassis and covers with several lock mounting options.
They also come standard the SmartTouch 720 controller with Bluetooth and Ethernet ports removed. They are equipped with all the software and additional control wiring needed to interface with many options and interlocks commonly used at correctional facilities.



Xtreme Drive™: Order optional XtremeDrive System for locations where roll resistant gates or harsh snow and ice conditions risk loss of drive wheel traction. XtremeDrive System increases traction with its innovative rack & prion-like design

SlideDriver II Installed Options

Name	Order code	Description
Cover Corr, Deadbolt, SD200 Green	S-SD2-4-52	Corrections facility upgrade with heavy gauge cover for SD200V. Includes lock plate for 1010 deadbolt style lock plate. Lock not included.
Cover Corr, Padlock, SD200 Green	S-SD2-4-57	Corrections facility upgrade with heavy gauge cover for SD200V. Includes padlock hasp. Lock not included.
Cover Corr, T-Lock, SD200 Green	S-SD2-4-47	Corrections facility upgrade with heavy gauge cover for corrections facilities for SD200V. With T-lock.
Cover, Corr, Deadbolt, 304 SS	S-SD2-4-16	Corrections facility upgrade with Stainless steel chassis and cover. Includes lock plate for 1010 deadbolt style lock plate, lock not included.
Cover, Corr, Deadbolt, Galvanized	S-SD2-4-15	Corrections facility upgrade with galvanized chassis and heavy gauge galvanized cover. Includes series 1010 deadbolt style lock plate. Lock not included.
Cover, Corr, Deadbolt, Green	S-SD2-4-12	Corrections facility upgrade with heavy gauge cover for correctional facility with series 1010 deadbolt style lock plate. Lock not included.
Cover, Corr, Padlock, 304 SS	S-SD2-4-34	Corrections facility upgrade with stainless steel chassis and cover. Includes padlock hasp. Lock not included.
Cover, Corr, Padlock, Galvanized	S-SD2-4-33	Corrections facility upgrade with galvanized chassis and heavy gauge galvanized cover. Includes padlock hasp. Lock not included.
Cover, Corr, Padlock, Green	S-SD2-4-30	Corrections facility upgrade with heavy gauge cover. Includes padlock hasp. Lock not included.
Cover, Corr, T-Lock, Galvanized	S-SD2-4-24	Corrections facility upgrade with galvanized chassis and heavy gauge cover, with T-lock.
Cover, Corr, T-Lock, Green	S-SD2-4-20	Corrections facility upgrade with heavy gauge cover. With T-lock.
Cover, No Lock, 304 SS	S-SD2-4-04	Stainless steel chassis and cover.
Cover, No Lock, Custom Color	S-SD2-4-01	Custom paint color chassis and cover. Contact factory for colors available.
Cover, No Lock, Custom Color, SD200	S-SD2-4-38	Custom color cover for SD200V.
Cover, No Lock, Galvanized	S-SD2-4-03	Chassis and Cover, hot dipped galvanized option for use in highly corrosive environments.
Cover, T-Lock, 304 SS	S-SD2-4-09	Stainless steel chassis and locking cover with T-lock.
Cover, T-Lock, Custom Color	S-SD2-4-06	Custom paint color chassis and cover with T-lock. Zinc based undercoat with powder coat textured finish coat. Contact factory for colors available.
Cover, T-Lock, Galvanized	S-SD2-4-08	Chassis and locking Cover with T-lock, hot dipped galvanized option for use in highly corrosive environments.
Cover, T-Lock, Green	S-SD2-4-07	Cover, Locking, Standard Green Cover, T-Lock.
Cover, T-Lock, Green SD200	S-SD2-4-43	Standard cover with T-Lock for SD200V.
Heater, 120 VAC	S-SD2-8-01	Heater with thermostat and contractor, 120VAC.
Heater, 208 - 240VAC	S-SD2-8-02	Heater with thermostat and contractor, 208-240VAC.
Heater, 480 VAC	S-SD2-8-03	Heater with thermostat and contractor, 480VAC.
Packaging, Export, SD 200	S-SD2-6-04	Certified heat treated wood crate for export shipping, SlideDriver 200V.
Packaging, Export, Standard	S-SD2-6-03	Certified heat treated wood crate for export shipping, all models except SlideDriver 200V.
Release, Key Operated	S-SD2-9-01	Key operated cable release mechanism, operator mounted. Not available on SD200V
SD15, 110 VAC 1PH 50HZ	S-SD2-2-2A	50Hz motor option for regions with 50Hz input power.
SD15, 220 VAC 1PH 50HZ	S-SD2-2-2U	50Hz motor option for regions with 50Hz input power.
SD15, 220 VAC 3PH 50HZ	S-SD2-2-2B	50Hz motor option for regions with 50Hz input power.
SD15, 380 VAC 3PH 50HZ	S-SD2-2-2V	50Hz motor option for regions with 50Hz input power.
SD200V, DC 24V	S-SD2-2-2T	24VDC model for use with DC Power Supply DCPS-150. DC Power supply ordered separately.
SD40, 110 VAC 1PH 50HZ	S-SD2-2-2E	50Hz motor option for regions with 50Hz input power.
SD40, 220 VAC 1PH 50HZ	S-SD2-2-2Y	50Hz motor option for regions with 50Hz input power.

SlideDriver II Installed Options

Name	Order code	Description
SD40, 220 VAC 3PH 50HZ	S-SD2-2-2F	50Hz motor option for regions with 50Hz input power.
SD40, 380 VAC 3PH 50HZ	S-SD2-2-2Z	50Hz motor option for regions with 50Hz input power.
SD40, DC 24V	S-SD2-2-2J	24VDC model for use with DC Power Supply DCPS-60. DC Power supply ordered separately.
Solenoid Deadbolt Lock, 120 VAC	S-SD2-7-01	Internal solenoid operated deadbolt gate lock for use with flanged drive rail. 120VAC.
Solenoid Deadbolt Lock, 208/240 VAC	S-SD2-7-02	Internal solenoid operated deadbolt gate lock for use with flanged drive rail. 208-240VAC.
Xtreme Drive, 6 in wheel	S-SD2-3-03	6 inch diameter XtremeDrive wheel. Use with SD15 and SD40.
Xtreme Drive, 8 in wheel	S-SD2-3-04	Use with SD50F.

SlideDriver II Parts and Accessories

Name	Part Number	Description
Base Extension	MX001033	Base extension, SlideDriver green, raises operator 12 inches for improved electrical access. For SlideDriver models SD15, SD40, SD50F, and SD80V. 52 lb.
Base Extension, Custom Color	MX000951	Base extension, custom color, for SlideDriver models SD15, SD40, SD50F, and SD80V.
Beacon, Strobe, Amber, 24VDC	MX000997	24VDC Amber Beacon Strobe.
Detector, Vehicle, Hy5B™ 2.0	MX4621	Improved loop detector module with digital interface to SmartCNX and all other HySecurity controllers. Automatically sets sensitivity. Automatically compensates for gate movement. Advanced loop diagnostics.
Drive Rail Roll Pin	MX000814	Roll pin, 6 x 100 mm for splicing rail, 2 pins per connection, for standard or grooved drive rail.
Drive Rail, Aluminum, Grooved, No Flange, 14 ft	MX3885	Aluminum drive rail, standard, underside grooves for improved wet traction, no flange, 14 ft length.
Drive Rail, Aluminum, Grooved, No Flange, 14 ft, Bundle of 12	MX3886	Aluminum drive rail, standard, underside grooves for improved wet traction, no flange, 14 ft length, 12 piece bundle, save per piece when purchasing by bundle.
Drive Rail, Aluminum, Non-Grooved, Flanged, 14 ft	MX3887	Aluminum drive rail, non-grooved, flanged, 14 ft length.
Edge Channel, 10 ft	MX4219-03	Aluminum channel, mounts low and high profile edge sensors, 10 ft.
Edge Channel, 5 ft	MX4219-02	Aluminum channel, mounts low and high profile edge sensors, 5 ft.
Edge Sensor Assembly, Channel Mount, High Profile	AS1502-0440-05	High profile channel mount ASO edge sensor, preassembled with end caps and aluminum mounting channel, 5 ft, 1 x 1.75 inch. (1.5 m, 25 x 45 mm)
Edge Sensor Assembly, Channel Mount, Low Profile	AS1502-0430-05	Low profile channel mount ASO edge sensor, preassembled with end caps and aluminum mounting channel, 5 ft, 1 x 1.25 inch (1.5 m, 25 x 30 mm).
Edge Sensor Assembly, Wraparound, Round	AS1501-0760	Round ASO wraparound edge sensor for use on 2 inch diameter pole. Three contact surfaces for sensing contact in any direction. 5 ft x 2 inch (1.5 m x 51 mm).
Edge Sensor Assembly, Wraparound, Square	AS1501-0790	Square ASO wraparound edge sensor for use on 2 inch square pole. Three contact surfaces for sensing contact in any direction. 5 ft x 2 inch (1.5 m x 51 mm).
Edge Sensor Roll, Channel Mount, High Profile, 82 ft	AS1502-0440	High profile channel mount ASO edge sensor, 82 ft roll x 1 x 1.75 inch (25 m x 25 x 45 mm) Used to create custom length edge sensors. Purchase channel and two end cap types to complete system.
Edge Sensor Roll, Channel Mount, Low Profile, 82 ft	AS1502-0430	Low profile channel mount ASO edge sensor, 82 ft roll x 1 x 1.25 inch (25 m x 25 x 30 mm). Used to create custom length edge sensors. Purchase channel and two end cap types to complete system.
End Cap, Edge, High Profile, 10k	AS1804-1630	Replacement end cap for high profile ASO edge sensor, with 10k resistive termination, 1 x 1.75 inch (25 x 44 mm).
End Cap, Edge, High Profile, No Resistor	AS1804-0490	Replacement end cap for ASO edge sensor without resistive termination to make a non-monitored edge to function with pre-2016 operators, 1 x 1.75 inch (25 x 44 mm).
End Cap, Edge, High Profile, Wire Leads	AS1804-0650	Replacement end cap for high profile ASO edge sensor, with wire leads, 1 x 1.75 inch (25 x 44 mm).
End Cap, Edge, Low Profile, 10K	AS1804-1620	Replacement end cap for low profile ASO edge sensor, with 10k resistive termination, 1 x 1.25 inch (25 x 32 mm).
End Cap, Edge, Low Profile, No Resistor	AS1804-0480	Replacement end cap for ASO edge sensor without resistive termination to make a non-monitored edge to function with pre-2016 operators, 1 x 1.25 inch (25 x 32 mm).
End Cap, Edge, Low Profile, Wire Leads	AS1804-0640	Replacement end cap for low profile ASO edge sensor, with wire leads, 1 x 1.25 inch (25 x 32 mm).
Heater Kit, SlideDriver II, 115VAC	MX5474	Heater Kit, SlideDriver II, 115VAC. Includes heater, thermostat, harness, contactor, and hardware.
Heater Kit, SlideDriver II, 240VAC	MX5475	Heater Kit, SlideDriver II, 240VAC. Includes heater, thermostat, harness, contactor, and hardware.
Heater Kit, SlideDriver II, 480VAC	MX5476	Heater Kit, SlideDriver II, 480VAC. Includes heater, thermostat, harness, contactor, and hardware.
Limit Sensor, Contactless, SlideDriver II	MX5493	Limit Sensor, Contactless, SlideDriver II. Kit includes sensor, mounting bracket, and hardware.
Lock Kit, Drive Rail, 115VAC	MX5534-01	Lock Kit, Drive Rail, 115VAC. Solenoid lock engages drive rail for added security. Mounts inside SlideDriver II chassis. Requires flanged drive rail.
Lock Kit, Drive Rail, 208-240VAC	MX5534-02	Lock Kit, Drive Rail, 208-240VAC. Solenoid lock engages drive rail for added security. Mounts inside SlideDriver II chassis. Requires flanged drive rail.

SlideDriver II Parts and Accessories

Name	Part Number	Description
Module, I/O Expansion	MX5823	Module, I/O Expansion. Use with SmartTouch 725 controller.
Nut, Lug, 5/16-24, (Qty 4)	MX4993	LUG NUT, 5/16-24, QTY. 4. For use with new aluminum wheels.
Photo Eye Kit, Reflective, 40 ft, 24VDC	MX000999	Reflective photo eye kit, 40 ft range, AC or 24VDC, includes reflector, mounting bracket and hardware.
Photo Eye, Through Beam, 65 ft	MX5972-01	Through beam photo eye with integrated hood. Includes mounting hardware
Push Button Station, 2 Button	MX001180	Push button station, 2 button, open/close (NEMA 1).
Push Button Station, 3 Button	MX001174	Push button control station, 3 button, open/close/stop (NEMA 1).
Release, Fire and Emergency Access Lock Box	MX3095	Fire and emergency access lock box with manual release allows emergency vehicles fast and easy entry.
Remote Control Kit, OXI	MX4349	Remote control kit contains an OXIBD/A receiver, two ON2E remotes, and an ABF antenna. Use with any controller compatible with OXI receivers.
Signs, Literature Kit, French Canadian	MX3628-02	French Canadian voltage and warning labels required for compliance with ETL/CSA standards. Includes two 8.5 x 11 inch Moving Gate Warning (Advertissement) signs translated in French Canadian, and SlideDriver installation instructions.
Signs, Moving Gate Warning, English	MX3193-01	Two UL 325 moving gate warning signs, English, 8.5 x 11 inch aluminum, includes 8 zip ties.
SmartTouch 720 Controller	MX5846	SmartTouch controller with Bluetooth and Ethernet features removed for highly secure applications. Standard with corrections option of SlideDriver II. Includes USB drive with software.
SmartTouch 725 Controller	MX5822	SmartTouch 725 controller manages all operator functions and settings through a simple programmable interface. Features Bluetooth connection to smartphone installer app, HyNet remote management technology, intelligent inputs that work with 10K or pulsed monitored sensors, and 32 character OLED display. Includes USB drive with Software.
Snow Brushes	MX001223	Weather stripping brushes only, for SlideDriver
Snow Scraper blade	MX000525	One replacement scraper blade, 1/4 x 3.5 x 4.5 inch, 80D, for SlideDriver.
Snow Scrapers	MX001229	Snow scraper kit for SlideDriver, two scraper blades and hardware.
Snow Scrapers & Snow Brushes	MX001224	Snow brush and scraper kit, all SlideDriver and SlideDriver II models except the 200s.
Snow Scrapers & Snow Brushes, SlideDriver 200	MX001782	Snow brush and scraper kit, SlideDriver 200 (444) only.
Wheel Kit w/Hub, Aluminum, AdvanceDrive, 6 inch	MX002707	6 inch diameter AdvanceDrive Wheel, hub, lug nuts, and mounting hardware.
Wheel Kit w/Hub, Aluminum, AdvanceDrive, 8 inch	MX3132	8 inch diameter AdvanceDrive Wheel, hub, lug nuts, and mounting hardware.
Wheel Kit, Replacement, 6" AL with lug nuts	MX4994	6 inch diameter aluminum AdvanceDrive Wheel and four lug nuts.
Wheel Kit, Replacement, 8" AL with lug nuts	MX5223	8 inch diameter aluminum AdvanceDrive Wheel and four lug nuts.
XtremeDrive Rack Install Kit	MX002750	XtremeDrive rack install kit, assists in aligning the XtremeDrive rack with the drive rail. Includes drill jig, countersink bit, and transfer punch. Drive rack purchased separately
XtremeDrive Rack Kit, 25 inch	MX002599	XtremeDrive rack kit, includes hardware and 25 inch section of cogged rack.
XtremeDrive Wheel conversion Kit, 8 inch	MX5350	8 inch diameter XtremeDrive wheel conversion kit, including hub, lug nuts, and attachment hardware.
XtremeDrive Wheel Kit, 6 inch	MX5349	6 inch diameter XtremeDrive wheel kit, including hub, lug nuts, and attachment hardware.
XtremeDrive Wheel, Replacement, 6 inch with lug nuts	MX5351	6 inch diameter XtremeDrive wheel with four lug nuts.
XtremeDrive Wheel, Replacement, 8 inch with lug nuts	MX5352	XtremeDrive wheel replacement, 8 inch dia. Includes four lug nuts.



Swing Gate Operator

HydraSwing™	24
HydraSwing Technical Specifications.....	25
HydraSwing Models	26
HydraSwing Installed Options	27
HydraSwing Parts and Accessories.....	28



SwingRiser™	30
SwingRiser Technical Specifications.....	31
SwingRiser Models.....	32
SwingRiser Installed Options	34
SwingRiser Parts and Accessories.....	35

HydraSwing™

Compact and powerful for large swing gates or high wind applications.

Easy to install, easy to operate direct-drive opener provides a solution for every installation with multiple controller and power options.

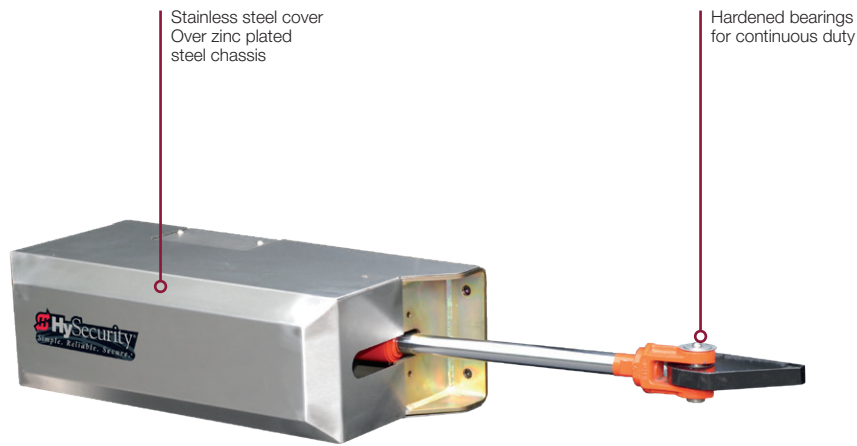

Powerful: Up to 15,000 lb/40 ft per leaf.



Reliable: UPS backup with optional AC Power Supply with HyInverter AC™.



Programmable: Field programmable to specific site requirements.



Gentle: Soft-start, soft-stop.



Applications: Dual or sequenced gate integration.



Troubleshooting: Easy system troubleshooting with onboard event log.



Secure: Heavy duty chassis, industrial grade components.



Made in USA: Designed, tested, and built within USA from globally sourced materials.



HydraSwing Technical Specifications

Model	HydraSwing 40	HydraSwing 40 Twin	HydraSwing 40F	HydraSwing 40F Twin	HydraSwing 80F	HydraSwing 150
Single or Twin	Single leaf	Twin (2 leaves)	Single leaf	Twin (2 leaves)	Single leaf	
Duty Cycle	Continuous					
Drive	VFD controlled Hydraulics					
Open/Close Time	15-20 seconds, field adjustable**		10-15 seconds, field adjustable**		15-25 seconds, field adjustable**	20-30 seconds, field adjustable**
Gate Length Max.	up to 24 ft (7.3 m)*	up to 16 ft (5 m) wide each leaf*	up to 16 ft (5 m) wide*	up to 16 ft (5 m) wide each leaf*	up to 30 ft (9 m) wide*	up to 40 ft (12 m) wide*
Gate Weight Max.	4,000 lb (1,814 kg)*	4,000 lb (1,814 kg) / leaf*	4,000 lb (1,814 kg)*	4,000 lb (1,814 kg) / leaf*	8,000 lb (3,629 kg)*	15,000 lb (6,804 kg)*
UPS Battery Backup Cycles	Optional 230V AC Power Supply w/HyInverter AC™***					
Temperature Rating	-40° to 158° F (-40° to 70° C)					
Single Phase Voltages	208/230V 50/60Hz, 208/230V 50/60Hz					
Three Phase Voltages	208/230V 50/60Hz or 380/460V 50/60Hz					
Communication	RS-232, RS-485					
User Controls	Smart Touch Controller with 70+ configurable settings. Smart Touch keypad and 32 character, OLED display or a PC using S.T.A.R.T. software.					
Relays	Three configurable user relays: one 30VDC, 3A solid state and two 250VAC, 10A electromechanical. Optional Hy8Relay™ for 8 additional relay outputs.					
Enclosure	Type 3R, 30w x 42h x 12d inch (76w x 107h x 30.5d cm)					
Finish	Zinc plated steel chassis with stainless steel cover				3/4 inch zinc plated steel chassis with black powder coated steel cover	
ETL Listed (UL 325)	Usage Class I, II, III, IV				Usage Class III, IV	
Warranty	5 year w/product registration					

* Gate length/weight specifications are dependent on height, percentage of open area on panel and anticipated wind speed.

** Actual open/close time dependent on gate weight/length, percentage of open area on panel and anticipated wind speed.

*** The operator's normal duty cycle and the actual number of gate cycles available from battery depends upon gate resistance to travel, cycle length, battery size, state of charge and health, ambient temperature, accessory power draw and frequency of gate cycles during power outage.

HydraSwing Models

Solution	Components	Name	Part Number	Weight	Dimensions	Freight Class
HydraSwing 40	HydraSwing 40 Drive Unit HydraSwing 40 Power Unit	HSG 40 Drive Unit	S-HSG-1-HF	150 lb	44"w x 26"d x 28"h	70
		HSG 40 Power Unit	S-HSP-1-AE	261 lb	40"w x 40"d x 50"h	70
HydraSwing 40 Twin	HydraSwing 40 Twin 1 Drive Unit HydraSwing 40 Twin 2 Drive Unit HydraSwing 40 Twin Power Unit	HSG 40 Twin 1 Drive Unit	S-HSG-1-HC	150 lb	44"w x 26"d x 28"h	70
		HSG 40 Twin 2 Drive Unit	S-HSG-1-HD	150 lb	44"w x 26"d x 28"h	70
		HSG 40 Twin	S-HSP-1-AC	261 lb	40"w x 40"d x 50"h	70
HydraSwing 40F	HydraSwing 40F Drive Unit HydraSwing 40F Power Unit	HSG 40F Drive Unit	S-HSG-1-HB	150 lb	44"w x 26"d x 28"h	70
		HSG 40F Power Unit	S-HSP-1-AD	261 lb	40"w x 40"d x 50"h	70
HydraSwing 40F Twin	HydraSwing 40F Twin 1 Drive Unit HydraSwing 40F Twin 2 Drive Unit HydraSwing 40F Twin Power Unit	HSG 40F Twin Drive Unit 1	S-HSG-1-HG	150 lb	44"w x 26"d x 28"h	70
		HSG 40F Twin Drive Unit 2	S-HSG-1-HI	150 lb	44"w x 26"d x 28"h	70
		HSG 40F Twin	S-HSP-1-AH	261 lb	40"w x 40"d x 50"h	70
HydraSwing 80F	HydraSwing 80F Drive Unit HydraSwing 80F Power Unit	HSG 80F Drive Unit	S-HSG-1-HE	250 lb	44"w x 26"d x 28"h	70
		HSG 80F Power Unit	S-HSP-1-AF	261 lb	40"w x 40"d x 50"h	70
HydraSwing 150	HydraSwing 150 Drive Unit HydraSwing 150 Power Unit	HSG 150 Drive Unit	S-HSG-1-HA	250 lb	44"w x 26"d x 28"h	70
		HSG 150 Power Unit	S-HSP-1-AG	261 lb	40"w x 40"d x 50"h	70



Optional AC Power Supply with HyInverter™ AC provides UPS battery backup for 208/230VAC single-phase, 1 hp AC gate operators, providing up to 100 cycles UPS backup after an AC power loss. (See "AC Power Supply with HyInverter AC" on page 63).



Twin models for bi-parting site applications. Reduce cost of operator and installation with only one power unit and one control unit for the twin posts. Separate HydraSupply enclosure containing Smart Touch Controller and hydraulic power unit is remotely located, up to 100 ft, from the gate. Gate sequencing with leaf delay requires separate power units for each leaf.

HydraSwing Installed Options

Name	Part Number	Description
Cover, Custom Color, HydraSwing 40/40F	S-HSG-5-42	Ultra-durable (TGIC) powder coat over stainless steel cover. Passes a 1,000 hour salt spray test and exhibits excellent abrasion resistance. Contact factory for colors available.
Crate, Export Shipping, HydraSupply	S-HSG-B-01	Certified heat treated wood crate for export shipping, HydraSupply
Heater, 230VAC, HydraSupply	S-HSG-6-06	Heater with thermostat, 208-230VAC for HydraSupply.
Heater, 460VAC, HydraSupply	S-HSG-6-10	Heater with thermostat, 460VAC for HydraSupply.
Radio Receiver, Single Channel, Open	S-HSG-9-00	Single channel receiver and coax antenna, wired for open control only.

HydraSwing Parts and Accessories

Name	Part Number	Description
Base Extension, HydraSwing 80F/150	MX3225-02	Heavy HydraSwing base extension/standoff, commonly used on face mounted hinges. HydraSwing 80F, 150.
Beacon, Strobe, Amber, 24VDC	MX000997	24VDC Amber Beacon Strobe.
Bit, Torx, T40	MX3510	T40 Torx bit, tamper resistant.
Board, Accessory Power Supply Kit, 12VDC, 3A	MX000079	Optional accessory power supply board, 24VDC input, 12VDC output.
Cable, Smart Touch Controller	MX4138	Download cable with USB to RS-232 adapter, 6 ft, connects laptop to Smart Touch Controller, use with Smart Touch Analyze and Retrieve Tool (S.T.A.R.T.).
Detector, Vehicle, Hy5B™ 2.0	MX4621	Improved loop detector module with digital interface to SmartCNX and all other HySecurity controllers. Automatically sets sensitivity. Automatically compensates for gate movement. Advanced loop diagnostics.
Edge Channel, 10 ft	MX4219-03	Aluminum channel, mounts low and high profile edge sensors, 10 ft.
Edge Channel, 5 ft	MX4219-02	Aluminum channel, mounts low and high profile edge sensors, 5 ft
Edge Sensor Assembly, Channel Mount, High Profile	AS1502-0440-05	High profile channel mount ASO edge sensor, preassembled with end caps and aluminum mounting channel, 5 ft, 1 x 1.75 inch (1.5 m, 25 x 45 mm).
Edge Sensor Assembly, Channel Mount, Low Profile	AS1502-0430-05	Low profile channel mount ASO edge sensor, preassembled with end caps and aluminum mounting channel, 5 ft, 1 x 1.25 inch (1.5 m, 25 x 30 mm).
Edge Sensor Assembly, Wraparound, Round	AS1501-0760	Round ASO wraparound edge sensor for use on 2 inch diameter pole. Three contact surfaces for sensing contact in any direction. 5 ft x 2 inch (1.5 m x 51 mm).
Edge Sensor Assembly, Wraparound, Square	AS1501-0790	Square ASO wraparound edge sensor for use on 2 inch square pole. Three contact surfaces for sensing contact in any direction. 5 ft x 2 inch (1.5 m x 51 mm).
Edge Sensor Module, N/C adapter	MX4018	Wired Edge Sensor N/C adapter (Hy2NC™), 2 channel.
Edge Sensor Roll, Channel Mount, High Profile, 82 ft	AS1502-0440	High profile channel mount ASO edge sensor, 82 ft roll x 1 x 1.75 inch (25 m x 25 x 45 mm) Used to create custom length edge sensors. Purchase channel and two end cap types to complete system.
Edge Sensor Roll, Channel Mount, Low Profile, 82 ft	AS1502-0430	Low profile channel mount ASO edge sensor, 82 ft roll x 1 x 1.25 inch (25 m x 25 x 30 mm). Used to create custom length edge sensors. Purchase channel and two end cap types to complete system.
End Cap, Edge, High Profile, 10k	AS1804-1630	Replacement end cap for high profile ASO edge sensor, with 10k resistive termination, 1 x 1.75 inch (25 x 44 mm).
End Cap, Edge, High Profile, No Resistor	AS1804-0490	Replacement end cap for ASO edge sensor without resistive termination to make a non-monitored edge to function with pre-2016 operators, 1 x 1.75 inch (25 x 44 mm).
End Cap, Edge, High Profile, Wire Leads	AS1804-0650	Replacement end cap for high profile ASO edge sensor, with wire leads, 1 x 1.75 inch (25 x 44 mm).
End Cap, Edge, Low Profile, 10K	AS1804-1620	Replacement end cap for low profile ASO edge sensor, with 10k resistive termination, 1 x 1.25 inch (25 x 32 mm).
End Cap, Edge, Low Profile, No Resistor	AS1804-0480	Replacement end cap for ASO edge sensor without resistive termination to make a non-monitored edge to function with pre-2016 operators, 1 x 1.25 inch (25 x 32 mm).
End Cap, Edge, Low Profile, Wire Leads	AS1804-0640	Replacement end cap for low profile ASO edge sensor, with wire leads, 1 x 1.25 inch (25 x 32 mm).
Heater Kit, 230VAC	MX001110	Heater kit with thermostat, 208/230VAC for StrongArm, SwingRiser, HydraLift, HydraSwing, HydraWedge.
Heater Kit, 460VAC	MX001111	Heater kit with thermostat, 460VAC, includes relay contactor, for SwingRiser, HydraLift, HydraSwing, HydraWedge.
Noise Isolator	MX001162	Open/Close/Stop noise/lightning isolator (long distance module).
Photo Eye Kit, Reflective, 40 ft, 24VDC	MX000999	Reflective photo eye kit, 40 ft range, AC or 24VDC, includes reflector, mounting bracket and hardware.
Photo Eye, Through Beam, 65 ft	MX5972-01	Through beam photo eye with integrated hood. Includes mounting hardware.
Receiver, Remote, Antenna and Coax Cable	MX001179	Antenna and coax cable for single and dual channel receiver.
Receiver, Remote, Single Channel	MX001181	Linear Multicode™ receiver, 1 channel, 300MHz, includes antenna and 3 ft cable.

HydraSwing Parts and Accessories

Name	Part Number	Description
Relay Module, Hy8Relay™, Smart Touch	MX3307-02	Extended Hy8Relay module provides 8 additional programmable relay outputs for Smart Touch operators.
Signs, Moving Gate Warning, English	MX3193-01	Two UL 325 moving gate warning signs, English, 8.5 x 11 inch aluminum, includes 8 zip ties.
Signs, Moving Gate Warning, French	MX3193-02	Two UL 325 moving gate warning signs, French, 8.5 x 11 inch aluminum, includes 8 zip ties.
Timer, Clock, 7 day, 24 hour	MX001307	7 day 24 hour Clock Timer.

SwingRiser™

Unique two-axis movement to clear ground obstacles. A unique swing gate operator with smooth lift and swing action to clear obstacles such as snow, or road inclines.

HydraSupply power unit drives one or two gate leaves, including versatile controls in weather resistant enclosure.



Custom height post available. Industrial grade components ensure low maintenance and long life.



Powerful: Up to 15,000 lb/40 ft per leaf.



Reliable: UPS backup with optional AC Power Supply w/HyInverter AC™.



Programmable: Field programmable to specific site requirements.



Gentle: Soft-start, soft-stop.



Applications: Dual or sequenced gate integration.



Troubleshooting: Easy system troubleshooting with onboard event log.



Made in USA: Designed, tested, and built within USA from globally sourced materials.



SwingRiser Technical Specifications

Model	SwingRiser 14	SwingRiser 14-Twin	SwingRiser 19	SwingRiser 19-Twin	SwingRiser 30	SwingRiser 30-Twin
Duty Cycle	Continuous					
Horsepower	1 hp	2 hp	1 hp	2 hp	1 hp	2 hp
Drive	Hydraulic					
Gate Length Max.*	up to 9 ft (3 m)	up to 9 ft (3 m) each leaf	up to 16 ft (5 m)	up to 16 ft (5 m) each leaf	up to 16 ft (5 m)	up to 16 ft (5 m) each leaf
Gate Weight Max.*	1,000 lb (453 kg)	1,000 lb (453 kg) / leaf	1,600 lb (726 kg)	1,600 lb (726 kg) / leaf	3,000 lb (1,361 kg)	3,000 lb (1,361 kg) / leaf
Open/Close Time	14 seconds		19 seconds		30 seconds	
Temperature Rating	-40° to 158° F (-40° to 70° C)					
1 Phase Power	115/208/230V 60Hz 110/220V 50Hz **	208/230V 60Hz 220V 50Hz **	115/208/230V 60Hz 110/220V 50Hz **	208/230V 60Hz 220V 50Hz **	115/208/230V 60Hz 110/220V 50Hz **	208/230V 60Hz 220V 50Hz **
3 Phase Power	208/230/460V 60Hz, 220/380/440V 50Hz					
Communication	RS-232, RS-485, Ethernet					
User Controls	Smart Touch Controller with 70+ configurable settings, programmed via the keypad and display or a PC using S.T.A.R.T. software.					
Relay	Three configurable user relays: one 30VDC, 3A solid state and two 250VAC, 10A electromechanical; Optional Hy8Relay™ for 8 additional relay outputs					
Finish	Zinc flame sprayed					
Enclosure	HydraSupply: Type 3R, 30w x 42h x 12d inch (76w x 107h x 30.5d cm)					
ETL Listed (UL 325)	Usage Class I, II, III, IV					
Warranty	5 year w/product registration					
UPS Battery Backup Power Options						
DC Power Supply with HyCharger DC †*	SwingRiser 14 UPS	SwingRiser 14-Twin UPS	SwingRiser 19 UPS	SwingRiser 19-Twin UPS	SwingRiser 30 UPS	SwingRiser 30-Twin UPS
AC Power Supply with HyInverter AC*	SwingRiser 14 with HyInverter AC	—	SwingRiser 19 with HyInverter AC	—	SwingRiser 30 with HyInverter AC	—

* The operator's normal duty cycle and the actual number of gate cycles available from battery depends upon gate resistance to travel, cycle length, battery size, state of charge and health, ambient temperature, accessory power draw and frequency of gate cycles during power outage.

** Refer to Installed Options on pricing for all 50Hz voltages, which are special order.

† 115V requires a 30A branch circuit. Choose voltage with care as chargers are not field convertible.

To enable fully automatic operation, all SWING gate operators require a minimum of ONE monitored external entrapment protection sensor to protect entrapment zones in either the open or close direction of travel. However, an additional monitored sensor is required if there is a risk of entrapment in both directions of gate travel. Visit hysecurity.com/gatesafety for more information on UL 325 standards and gate safety.

SwingRiser Models

Solution	Models	Component Name	Part Number	Weight	Dimensions	Freight Class
SwingRiser 14	SwingRiser Post SwingRiser 14 Power Unit	HRG 220 POST	S-SWR-1-D0	500 lb	96" w x 26" d x 23" h	70
		HRG 220-A ST	S-HSP-1-70	261 lb	40" w x 40" d x 50" h	70
SwingRiser 14 UPS	SwingRiser Post SwingRiser 14 DC Power Unit DC Power Supply 60	HRG 220 POST	S-SWR-1-D0	500 lb	96" w x 26" d x 23" h	70
		HRG 220-A DC ST	S-HSP-1-80	261 lb	40" w x 40" d x 50" h	70
		DCPS-60	S-DCP-1-C0	335 lb	39" w x 28" d x 39" h	70
SwingRiser 14-Twin	SwingRiser Twin Post 1 SwingRiser Twin Post 2 SwingRiser 14-Twin Power Unit	HRG 222 POST 1	S-SWR-1-D1	500 lb	96" w x 26" d x 23" h	70
		HRG 222 POST 2	S-SWR-1-D2	261 lb	96" w x 26" d x 23" h	70
		HRG 222-A ST	S-HSP-1-73	261 lb	40" w x 40" d x 50" h	70
SwingRiser 14-Twin UPS	SwingRiser Twin Post 1 SwingRiser Twin Post 2 DC Power Supply 120 SwingRiser 14-Twin UPS Power Unit	HRG 222 POST 1	S-SWR-1-D0	500 lb	96" w x 26" d x 23" h	70
		HRG 222 POST 2	S-HSP-1-80	500 lb	96" w x 26" d x 23" h	70
		DCPS-120	S-DCP-1-C1	335 lb	39" w x 28" d x 39" h	70
		HRG 222-A DC ST	S-HSP-1-83	261 lb	40" w x 40" d x 50" h	70
SwingRiser 19	SwingRiser Post SwingRiser 19 Power Unit	HRG 220 POST	S-SWR-1-D0	500 lb	96" w x 26" d x 23" h	70
		HRG 220 B ST	S-HSP-1-71	261 lb	40" w x 40" d x 50" h	70
SwingRiser 19 UPS	SwingRiser 19 UPS Power Unit SwingRiser Post DC Power Supply 60	HRG 220-B DC ST	S-HSP-1-81	261 lb	40" w x 40" d x 50" h	70
		HRG 220 POST	S-SWR-1-D0	500 lb	96" w x 26" d x 23" h	70
		DCPS-60	S-DCP-1-C0	335 lb	39" w x 28" d x 39" h	70
SwingRiser 19-Twin	SwingRiser Twin Post 1 SwingRiser Twin Post 2 SwingRiser 19-Twin Power Unit	HRG 222 POST 1	S-SWR-1-D1	500 lb	96" w x 26" d x 23" h	70
		HRG 222 POST 2	S-SWR-1-D2	500 lb	96" w x 26" d x 23" h	70
		HRG 222-B ST	S-HSP-1-74	261 lb	40" w x 40" d x 50" h	70
SwingRiser 19-Twin UPS	SwingRiser Twin Post 1 SwingRiser Twin Post 2 SwingRiser 19-Twin UPS Power Unit DC Power Supply 120	HRG 222 POST 1	S-SWR-1-D1	500 lb	96" w x 26" d x 23" h	70
		HRG 222 POST 2	S-SWR-1-D2	500 lb	96" w x 26" d x 23" h	70
		HRG 222-B DC ST	S-HSP-1-84	261 lb	40" w x 40" d x 50" h	70
		DCPS-120	S-DCP-1-C1	335 lb	39" w x 28" d x 39" h	70
SwingRiser 30	SwingRiser Post SwingRiser 30 Power Unit	HRG 220 POST	S-SWR-1-D0	500 lb	96" w x 26" d x 23" h	70
		HRG 220-C ST	S-HSP-1-72	261 lb	40" w x 40" d x 50" h	70
SwingRiser 30 UPS	SwingRiser Post DC Power Supply 60 SwingRiser 30 UPS Power Unit	HRG 220 POST	S-SWR-1-D0	500 lb	96" w x 26" d x 23" h	70
		DCPS-60	S-DCP-1-C0	335 lb	39" w x 28" d x 39" h	70
		HRG 220-C DC ST	S-HSP-1-82	261 lb	40" w x 40" d x 50" h	70

SwingRiser Models

Solution	Models	Component Name	Part Number	Weight	Dimensions	Freight Class
SwingRiser 30-Twin	SwingRiser Twin Post 1 SwingRiser Twin Post 2 SwingRiser 30-Twin Power Unit	HRG 222 POST 1	S-SWR-1-D1	500 lb	96"w x 26"d x 23"h	70
		HRG 222 POST 2	S-SWR-1-D2	500 lb	96"w x 26"d x 23"h	70
		HRG 222-C ST	S-HSP-1-75	261 lb	40"w x 40"d x 50"h	70
SwingRiser 30-Twin UPS	SwingRiser Twin Post 1 SwingRiser Twin Post 2 SwingRiser 30-Twin UPS Power Unit DC Power Supply 120	HRG 222 POST 1	S-SWR-1-D1	500 lb	96"w x 26"d x 23"h	70
		HRG 222 POST 2	S-SWR-1-D2	500 lb	96"w x 26"d x 23"h	70
		HRG 222-C DC ST	S-HSP-1-85	261 lb	40"w x 40"d x 50"h	70
		DCPS-120	S-DCP-1-C1	335 lb	39"w x 28"d x 39"h	70



UPS Backup Power Solutions: The HySecurity DC Power Supply can be paired with DC power models of StrongArm to provide uninterruptible power. The UPS provides p to 300 cycles after an AC power loss. See "DC Power Supply with Installed Options" on page 41 section of this catalog.

The actual number of gate cycles available from battery depends upon the operator's duty cycle, battery size, state of charge, age, ambient temperature, accessory power draw and frequency of gate cycles during power outage.



Twin models for bi-parting site applications. Reduce cost of operator and installation with only one power unit and one control unit for the twin posts. Gate sequencing with leaf delay requires separate power units for each leaf.

A separate HydraSupply enclosure containing Smart Touch Controller and hydraulic power unit is remotely located, up to 100 ft, from the gate.

SwingRiser Installed Options

Name	Part Number	Description
Crate, Export Shipping, DC Power Supply	S-DCP-B-01	Certified heat treated wood crate for export shipping, DC Power Supply.
Crate, Export Shipping, HydraSupply	S-HSP-B-01	Certified heat treated wood crate for export shipping, HydraSupply.
Heater, 115VAC, HydraSupply	S-HSP-6-05	Heater with thermostat, 115VAC for SwingRiser, SlideDriver Modular.
Heater, 230VAC, HydraSupply	S-HSP-6-06	Heater with thermostat, 208-230VAC for HydraSupply.
Heater, 460VAC, HydraSupply	S-HSP-6-10	Heater with thermostat, 460VAC for HydraSupply.
Hinges, 2, Custom Positions	S-SWR-5-03	2 hinges on SwingRiser post in custom positions. One required for each post.
Hinges, 2, Standard Positions	S-SWR-5-01	2 hinges in standard positions.
Hinges, 3	S-SWR-5-04	1 extra hinge for SwingRiser post, one required per post.
Hinges, 4	S-SWR-5-05	2 extra hinges for SwingRiser post, one required per post.
Hinges, None	S-SWR-5-00	No hinges for SwingRiser post, one required per post.
Index Arm, 1, Custom Position	S-SWR-4-02	Index arm mounting bracket in custom position, one required per post.
Index Arm, 1, Standard Position	S-SWR-4-01	1 index arm in standard position for SwingRiser post.
Index Arm, None	S-SWR-4-00	No index arm bracket, no index arm, per post, special order.
Index Arms, 2	S-SWR-4-03	1 extra index arm for SwingRiser post, one required per post.
Index Arms, 3	S-SWR-4-04	2 extra index arms for SwingRiser post, one required per post.
Motor, Electric, 50Hz	S-HSP-2-80	220/380/440V 50Hz motor option. Longer lead time may apply.
Radio Receiver, Single Channel, Open	S-HSP-9-00	Single channel receiver and coax antenna, wired for open control only.
Top Cap, 4 inch Pipe, 4-1/2 inch OD	S-SWR-6-02	Top cap for mounting SwingRiser post to 4 inch pipe. Pipe may be used in applications where it has multiple attachment points to a structure. It is not recommended for free standing applications.
Top Cap, 6 inch Pipe, 6-5/8 inch OD	S-SWR-6-03	Top cap for mounting SwingRiser post to 6 inch pipe.
Top Cap, 6 inch Square Tube	S-SWR-6-05	Top cap for mounting SwingRiser post to 6 inch square tubing.
Top Cap, 8 inch Pipe, 8-5/8 inch OD	S-SWR-6-04	Top cap for mounting SwingRiser post to 8 inch pipe.
Top Cap, Pilaster	S-SWR-6-00	Top cap for mounting SwingRiser post to pilaster.

SwingRiser Parts and Accessories

Name	Part Number	Description
Beacon, Strobe, Amber, 24VDC	MX000997	24VDC Amber Beacon Strobe.
Cable, Smart Touch Controller	MX4138	Download cable with USB to RS-232 adapter, 6 ft, connects laptop to Smart Touch Controller, use with Smart Touch Analyze and Retrieve Tool (S.T.A.R.T.).
Detector, Vehicle, Hy5B™ 2.0	MX4621	Improved loop detector module with digital interface to SmartCNX and all other HySecurity controllers. Automatically sets sensitivity. Automatically compensates for gate movement. Advanced loop diagnostics.
Edge Channel, 10 ft	MX4219-03	Aluminum channel, mounts low and high profile edge sensors, 10 ft.
Edge Channel, 5 ft	MX4219-02	Aluminum channel, mounts low and high profile edge sensors, 5 ft.
Edge Sensor Assembly, Channel Mount, High Profile	AS1502-0440-05	High profile channel mount ASO edge sensor, preassembled with end caps and aluminum mounting channel, 5 ft, 1 x 1.75 inch (1.5 m, 25 x 45 mm).
Edge Sensor Assembly, Channel Mount, Low Profile	AS1502-0430-05	Low profile channel mount ASO edge sensor, preassembled with end caps and aluminum mounting channel, 5 ft, 1 x 1.25 inch (1.5 m, 25 x 30 mm).
Edge Sensor Assembly, Wraparound, Round	AS1501-0760	Round ASO wraparound edge sensor for use on 2 inch diameter pole. Three contact surfaces for sensing contact in any direction. 5 ft x 2 inch (1.5 m x 51 mm).
Edge Sensor Assembly, Wraparound, Square	AS1501-0790	Square ASO wraparound edge sensor for use on 2 inch square pole. Three contact surfaces for sensing contact in any direction. 5 ft x 2 inch (1.5 m x 51 mm).
Edge Sensor Module, N/C adapter	MX4018	Wired Edge Sensor N/C adapter (Hy2NC™), 2 channel.
Edge Sensor Roll, Channel Mount, High Profile, 82 ft	AS1502-0440	High profile channel mount ASO edge sensor, 82 ft roll x 1 x 1.75 inch (25 m x 25 x 45 mm) Used to create custom length edge sensors. Purchase channel and two end cap types to complete system.
Edge Sensor Roll, Channel Mount, Low Profile, 82 ft	AS1502-0430	Low profile channel mount ASO edge sensor, 82 ft roll x 1 x 1.25 inch (25 m x 25 x 30 mm). Used to create custom length edge sensors. Purchase channel and two end cap types to complete system.
End Cap, Edge, High Profile, 10k	AS1804-1630	Replacement end cap for high profile ASO edge sensor, with 10k resistive termination, 1 x 1.75 inch (25 x 44 mm).
End Cap, Edge, High Profile, No Resistor	AS1804-0490	Replacement end cap for ASO edge sensor without resistive termination to make a non-monitored edge to function with pre-2016 operators, 1 x 1.75 inch (25 x 44 mm).
End Cap, Edge, High Profile, Wire Leads	AS1804-0650	Replacement end cap for high profile ASO edge sensor, with wire leads, 1 x 1.75 inch (25 x 44 mm).
End Cap, Edge, Low Profile, 10K	AS1804-1620	Replacement end cap for low profile ASO edge sensor, with 10k resistive termination, 1 x 1.25 inch (25 x 32 mm).
End Cap, Edge, Low Profile, No Resistor	AS1804-0480	Replacement end cap for ASO edge sensor without resistive termination to make a non-monitored edge to function with pre-2016 operators, 1 x 1.25 inch (25 x 32 mm).
End Cap, Edge, Low Profile, Wire Leads	AS1804-0640	Replacement end cap for low profile ASO edge sensor, with wire leads, 1 x 1.25 inch (25 x 32 mm).
Heater Kit, 115VAC	MX001109	Heater kit with thermostat, 115VAC for StrongArm, SwingRiser.
Heater Kit, 230VAC	MX001110	Heater kit with thermostat, 208-230VAC for StrongArm, SwingRiser, HydraLift, HydraSwing, HydraWedge.
Heater Kit, 460VAC	MX001111	Heater kit with thermostat, 460VAC, includes relay contactor, for SwingRiser, HydraLift, HydraSwing, HydraWedge.
Index Arm	MX000281	Index arm, includes hardware.
Receiver, Remote, Antenna and Coax Cable	MX001179	Antenna and coax cable for single and dual channel receiver.
Receiver, Remote, Single Channel	MX001181	Linear Multicode™ receiver, 1 channel, 300MHz, includes antenna and 3 ft cable.
Relay Module, Hy8Relay™, Smart Touch	MX3307-02	Extended Hy8Relay module provides 8 additional programmable relay outputs for Smart Touch operators.
Timer, Clock, 7 day, 24 hour	MX001307	7 day 24 hour Clock Timer.
Transmitter, Remote, 1 Button	MX001202	Linear Multi-Code one button transmitter, 300 MHz.
Transmitter, Remote, 2 Button	MX001203	Remote transmitter, 2 button, 300MHz.

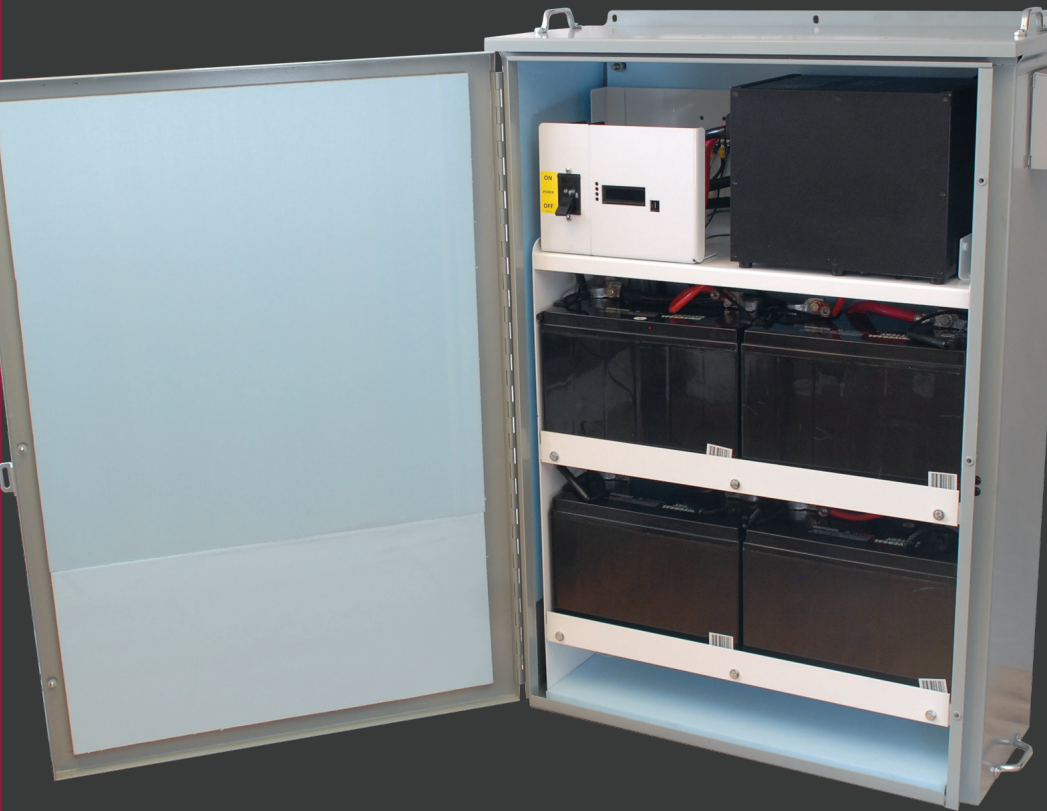

Power Supply

AC Power Supply with HyInverter™ AC	37
AC Power Supply with HyInverter AC Technical Specifications.....	38
AC Power Supply w/HyInverter AC Models	38
DC Power Supply with HyCharger™	39
DC Power Supply with HyCharger Technical Specifications.....	40
DC Power Supply with HyCharger Models.....	41
DC Power Supply with Installed Options.....	41
Parts and accessories for slide and swing gate operators	42

AC Power Supply with HyInverter™ AC

Trusted value, rugged performance. Easy to install, easy to operate direct drive gate opener.

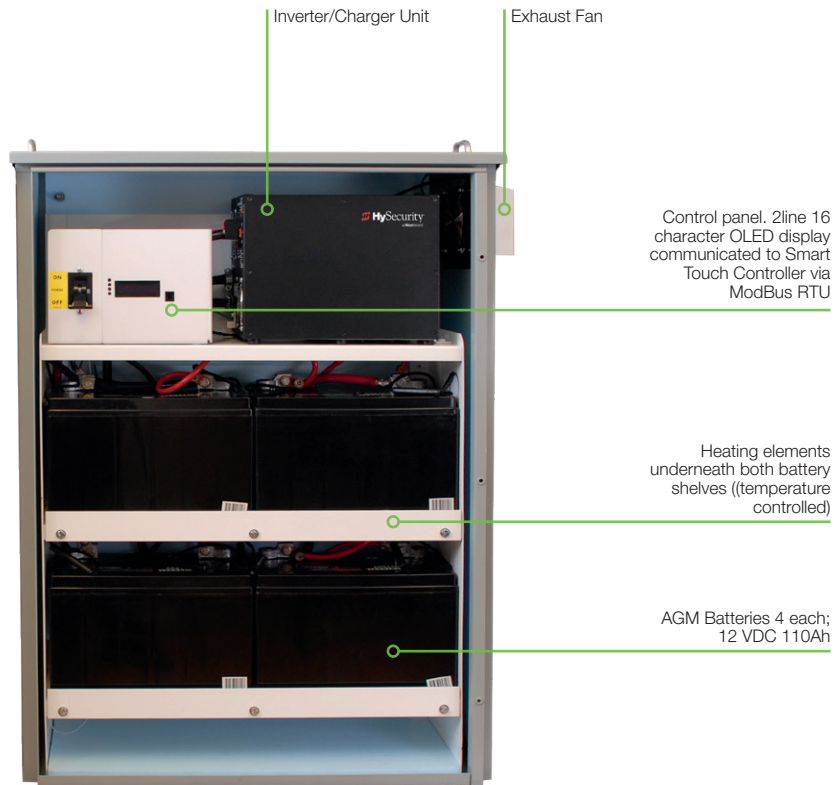

Quick: Quick power transfer; occurs in 1/2 AC cycle.



UPS: VFD models up to 2 hp now have the option for true Uninterruptible Power Supply (UPS).



Installation: May be installed anywhere on the branch circuit from panel to protected device.



Sine Wave: Pure sine wave output.



Soft-start: May be used with 1hp-2hp motor driven equipment equipped with soft-start controllers.



Resistive: May be used with resistive loads up to 3,000 Watts.

AC Power Supply with HyInverter AC Technical Specifications

Model	AC Power Supply w/HyInverter AC
Operators	HydraSwing; SlideDriver (15, 40, 50VF2/3), SlideDriver II (SD15, SD40, SD50F, SD80V) StrongArm; StrongArm M30/M50; SwingRiser (single leaf models)
Duty Cycle	See operator
Horsepower	1 hp, or up to 2 hp HySecurity operators with Variable Frequency Drive (VFD) controller
Temperature Rating	-40° to 122° F (-40° to 50°C) Heater and fan automatically adjust cabinet temperature for optimal battery life
Input Voltage	208/230V 50/60Hz
Batteries	4 AGM batteries for extended cycles. 110Ah, 12VDC each; 5200 Wh
Communication	Modbus RTU via RS-485
User Controls	Programmable with Smart Touch Controller or SmartTouch 720/725
Enclosure	NEMA 3R. Footman loops for lifting. Heater and fan automatically adjust cabinet temperature for optimal battery life.
ETL Listed (UL 325)	ETL Listed (UL 1778)
AC Loss Signal	Dry contact output to report power failure to gate operator (50mA, 0-36VDC)
Charger	Smart charge system conditions batteries
Humidity	5% to 95% relative humidity, non-condensing
Input Power	208/230VAC, single phase, 60/50Hz switch selectable
Output Power	230V 60Hz or 220V 50Hz, 3000VA
Recharge	Fast: Minimum 6 hour recharge; 12 hours for high cycle applications.
Retrofit	Easy. Same fit and finish as existing AC powered operator
Surge Power	6000VA, 10 seconds
Warranty	2 year (system and electronics), 1 year battery

AC Power Supply w/HyInverter AC Models

Solution	Models	Part Number	Weight (lbs)	Dimensions	Freight Class
AC Power Supply w/HyInverter AC	AC Power Supply with HyInverter	ACP7201	50 lb	42"w x 48"d x 49"h	70
AC Power Supply w/HyInverter AC	AC Power Supply with HyInverter Ac, Packaged for Export	ACP7202	50 lb	42"w x 48"d x 49"h	70

DC Power Supply with HyCharger™

Advanced UPS Power Supply with HyCharger DC. Secure access under all conditions.

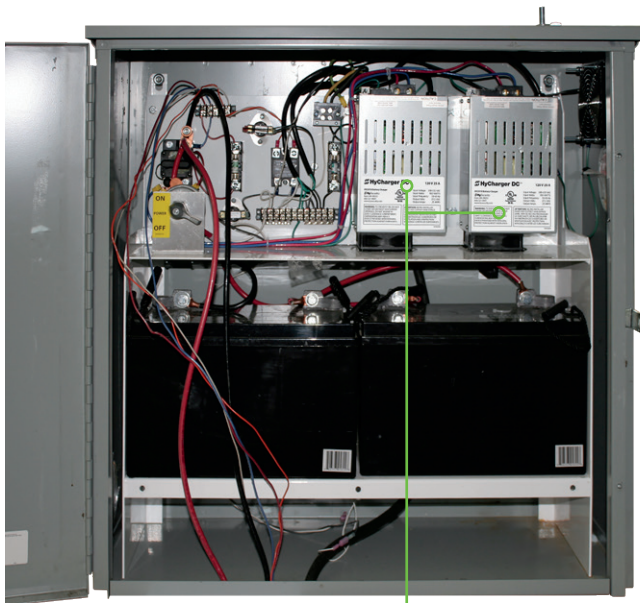

Redundant chargers
double reliability



Smart: Smart charge system uses high efficiency switching technology that optimizes battery conditioning, storage capacity and battery life.



Powerful: Supplies 50A of 24VDC power on continuous basis to both motor drive circuit or charger circuit. Burst mode supplies additional energy to gate operator, when needed.



Fast recharge: After AC power is restored, batteries are completely recharged in as little as 2 hours (12 hours when operating a high-traffic gate).



Adaptable: Easy replacement of existing, older DC chargers in HySecurity DC Supply Cabinets. If you are interested in replacing an older DC charger, contact HySecurity for replacement parts: MX2890-01 HyCharger DC 208/230V or MX2890-02 HyCharger DC 115V.**

DC Power Supply with HyCharger Technical Specifications

Model	DC Power Supply 60	DC Power Supply 120	DC Power Supply 150
Operators	SlideDriver II SD40DC, SD200VDC; StrongArm 14F UPS, 20 UPS, 28 UPS, 36 UPS; SwingRiser - All UPS models; ; HydraSupply XL UPS models.		
Horsepower	Works with up to 1hp rated operators	Works with up to 2hp rated operators	Works with up to 5hp rated operators
Temperature Rating	-40° to 158°F (-40° to 70°C) Heater & fan automatically adjust cabinet temperature for optimal battery life		
Single Phase Voltages	115† or 208-230V 50/60Hz Single Phase*		
Batteries	Two - 110Ah AGM batteries for extended cycles		
Enclosure	NEMA 3R with heater and fan		
ETL Listed	UL 325		
Burst Mode	Burst of power, when needed		
Charger	Smart charge system conditions battery		
Output Power	24V, 50A		
Recharge	Fast: Minimum 2 hour recharge; 12 hours for high cycle applications		
Warranty	2 year (system and electronics), 1 year battery		

* 115V DC Power Supply requires 30A branch circuit

PART NUMBER: MX2890-01 | MX2890-02

DC Power Supply with HyCharger Models

Solution	Models	Component Name	Part Number	Weight	Dimensions	Freight Class
DC Power Supply 60	DC Power Supply 60	DCPS-60	S-DCP-1-C0	335 lb	39"w x 28"d x 39"h	70
HydraSwing 40 Twin	DC Power Supply 120	DCPS-120	S-DCP-1-C1	335 lb	39"w x 28"d x 39"h	70
DC Power Supply 150	DC Power Supply 150	DCPS-150	S-DCP-1-C2	335 lb	39"w x 28"d x 39"h	70



24VDC UPS, Uninterruptible Power Supply, for HySecurity hydraulic industrial operators. The DC battery backup can only be integrated with DC motor-driven hydraulic industrial operators, thus, DC motor based hydraulic operators are purchased together with a DC Power Supply as an integrated pair. See individual hydraulic operator models for specifications.

Available in single phase only. Low voltage: 115V 50/60Hz (requires 30A branch circuit), or High voltage: 208-230V 50/60Hz (requires 15A branch circuit). Be certain to order the correct DC Power Supply voltage model as chargers are not field convertible.

Note: If a UPS is needed for an existing AC installation, consider using the AC Power Supply with HyInverter AC. (HySecurity does not support or warranty field conversions of AC powered operators to DC powered to add a battery backup. If a DC gate operator is to have a DC battery back-up, it must be ordered as a system from the factory to comply with the UL/ETL test certification we've obtained.)

Install Note: HySecurity DC Power Supply enclosure must be mounted within 10 ft (3 m) of the operator with a minimum of 6 gauge wire used to connect between the DC supply and gate operator. For longer distances, call HySecurity Tech Support. Includes two 110Ah sealed, AGM batteries for extended cycles.

DC Power Supply with Installed Options

Name	Part Number	Description
Crate, Export Shipping, DC Power Supply	S-DCP-B-01	Certified heat treated wood crate for export shipping, DC Power Supply

Parts and accessories for slide and swing gate operators

Just a few of the many accessories available. See operator parts section for more.



AMBER STROBE BEACON
24VDC



ASO EDGE SENSORS



HY5B™ VEHICLE DETECTOR



CLOCK TIMER



**PUSH BUTTON STATION, 2 OR 3
BUTTON**



PHOTO EYE KITS



**RADIO RECEIVERS
& TRANSMITTERS**



HY8RELAY™

Parts and accessories for slide and swing gate operators



REDUCE LOOP PROBLEMS WITH HY5B™

What if the vehicle detector and the gate operator could communicate? What would they say? It turns out there's lots to talk about.

Hy5B works in conjunction with the Smart Touch and Smart DC controllers on swing and slide gates to share information, resulting in the most advanced vehicle detector ever.



GIVE YOURSELF AN *EDGE*

These highly engineered, simple and rugged ASO edge sensors give installers and their customers peace of mind. They're incredibly easy to install, withstand typical rough shipment and installation handling, don't short due to water absorption, and they keep performing under the most severe climate and site conditions.



ADD USER RELAYS TO YOUR OPERATOR

Add 8 more inputs and 8 more output relays to your operators with SmartTouch 725 controllers using the IO expansion module. For Smart Touch and Smart DC machines the Hy8Relay™ adds 8 more relay outputs. All HySecurity controllers include a library of relay functions to solve most machine control needs.

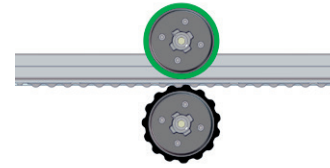

OPERATE HEAVY GATES MORE RELIABLY IN SEVERE WEATHER

The XtremeDrive System comes standard with SlideDriver 80 and 200 and is optional with all models. Provides maximum pull force and traction for exceptionally hard to move gates.*

Cogged lower wheel engages a matching cogged rack and increases traction the entire length of drive rail under the worst conditions.

Parts Diagrams

StrongArm Diagrams 45

Arm Hardware	45
Arm Hardware - Breakaway Bracket	46
Chassis, Drive and Electrical	47
Chassis, Drive and Electrical	48
Pump Pack	49

SlideDriver II Diagrams 50

Electrical components, all models	50
Motor and Pump Pack	51
SlideDriver II SD200V	52
Motor and Pump Pack	53

HydraSwing Diagrams 54

HydraSwing 40/40F Actuator	54
HydraSwing 80F/150 Actuator	55
Pump Pack	56
HydraSupply, Electrical	57

SwingRiser Diagrams..... 58

Post (typical).....	58
Pump Pack, Single (HRG 220)	59
Pump Pack, Twin (HRG 222)	60
Pump Pack, Twin (HRG 222)	61
HydraSupply, Electrical	62

AC and DC Power Supply Diagrams..... 63

AC Power Supply with HyInverter AC	63
DC Power Supply	63

StrongArm Diagrams

Arm Hardware

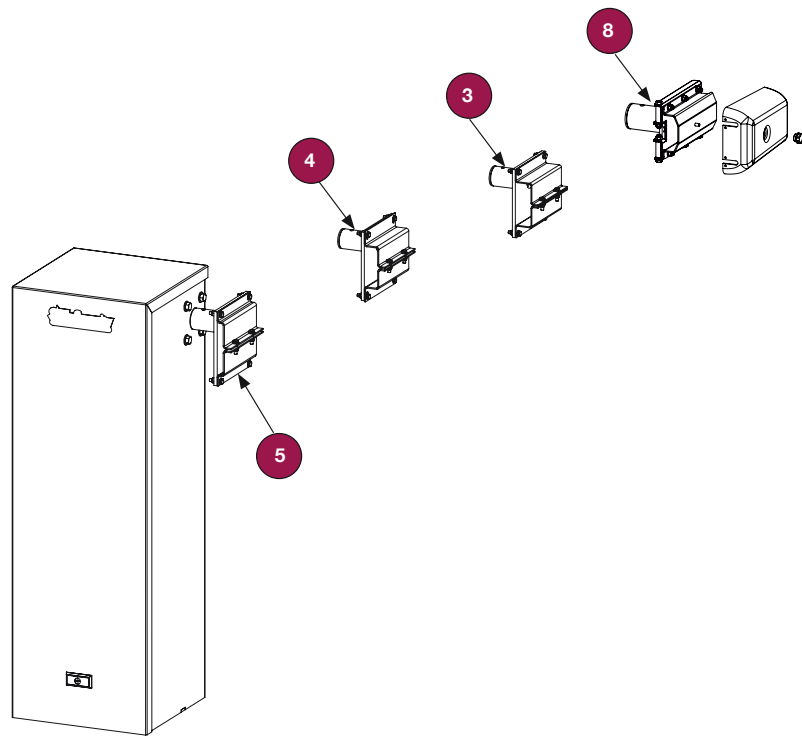

This drawing is a representation and should be used for parts reference only.

Item No.	Part Name	Part Number	StrongArm Models
1	Arm Sleeve, StrongArmDOT 28	MX3346	DOT 28
2	Bolt Assembly, Shear	MX4203	DOT 28
3	Bracket and Clamps, Side Mount, Aluminum	MX001090	all side mounted aluminum arms
4	Bracket and Clamps, Side Mount, Fiberglass	MX001043	all side mounted fiberglass arms
5	Bracket and Clamps, Side Mount, Wood	MX001044	all side mounted wood arms
6	Bracket and Yoke, Counterweight Type	MX001046	all arms 20' and longer

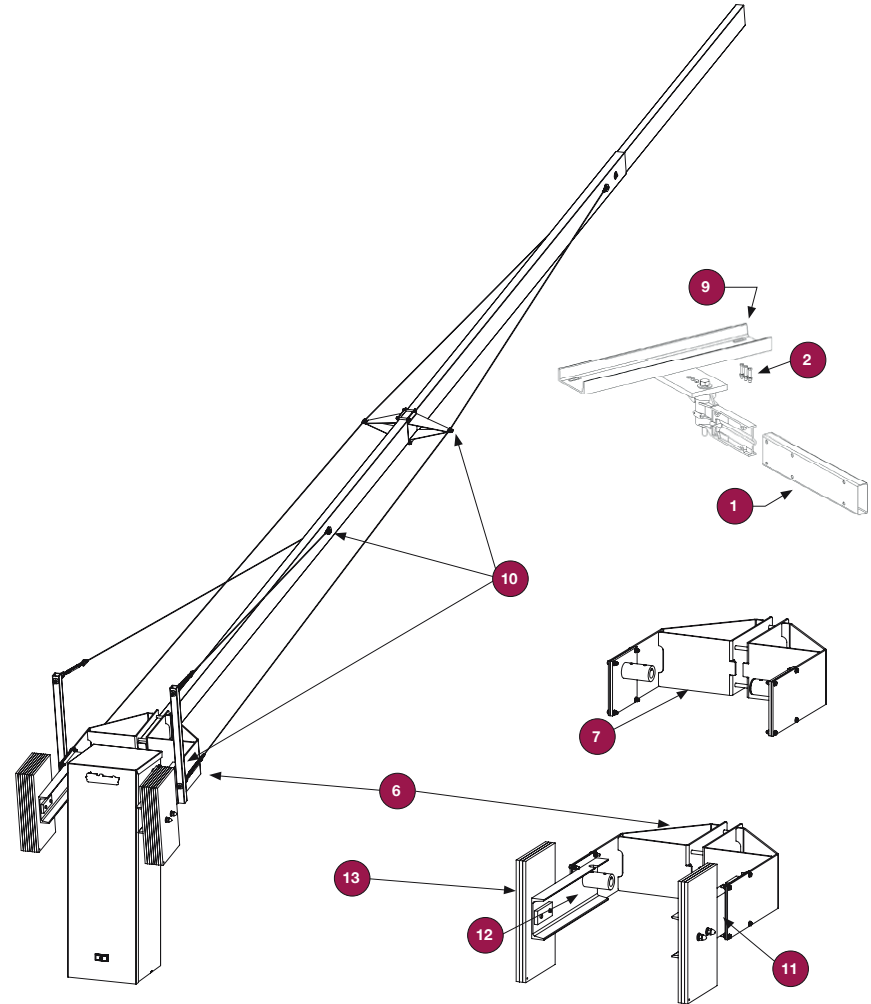

Item No.	Part Name	Part Number	StrongArm Models
7	Bracket and Yoke, Non-Counterweight Type	MX001047	all yoke mounted arms shorter than 20'
8	Bracket, Breakaway Arm w/Kill Switch Kit	MX3827	14F
9	Bracket, Breakaway Arm, StrongArmDOT 28	MX4202	DOT 28
10	Cable Tensioner and Arm Stabilizer Kit	MX001237	all yoke mounted arms 30' and longer
11	Counterweight Mount, Left	MX000641	all arms 20' and longer
12	Counterweight Mount, Right	MX000642	all arms 20' and longer

StrongArm Diagrams

Arm Hardware - Breakaway Bracket

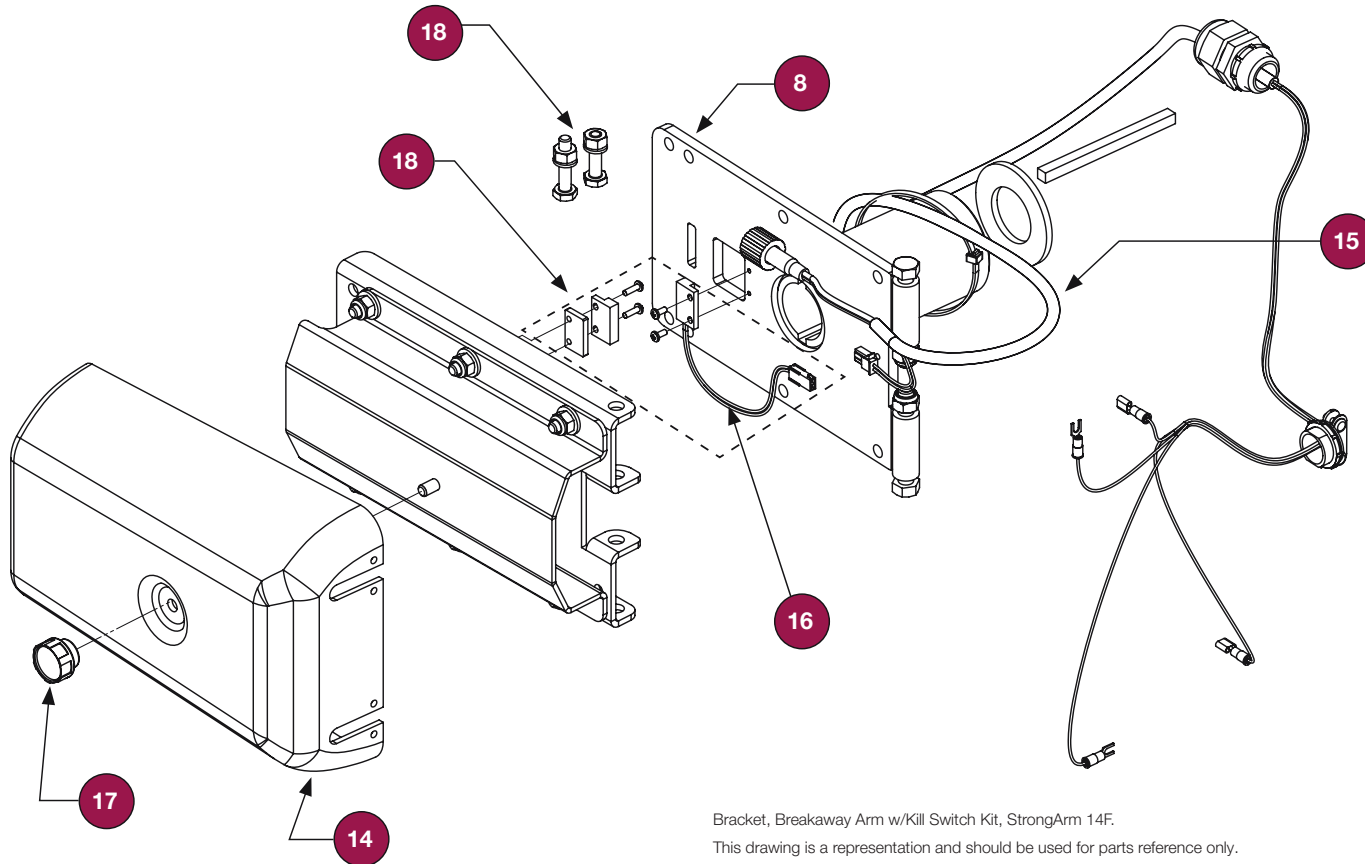

Bracket, Breakaway Arm w/Kill Switch Kit, StrongArm 14F.

This drawing is a representation and should be used for parts reference only.

Item No.	Part Name	Part Number	StrongArm Models
13	Counterweight, Barrier Arm	MX000566	all arms 20' and longer, see Arm Option for weight requirements.
14	Cover, Breakaway Bracket, HyProtect™	MX3126	14F
15	Harness, LED Light/Kill Switch	MX4057	14F
16	Kill Switch Kit	MX4402	14F
17	Knob, Cover, Breakaway Arm Bracket w/Kill Switch	MX002653	14F

Item No.	Part Name	Part Number	StrongArm Models
18	Bracket, Breakaway Arm, Hardware Kit,	MX3104	14F
Not shown	Lights, Flexible, 10 ft	MX4124-10	14F
Not shown	Lights, Flexible, 12 ft	MX4124-12	14F
Not shown	Lights, Flexible, 14 ft	MX4124-14	14F

StrongArm Diagrams

Chassis, Drive and Electrical

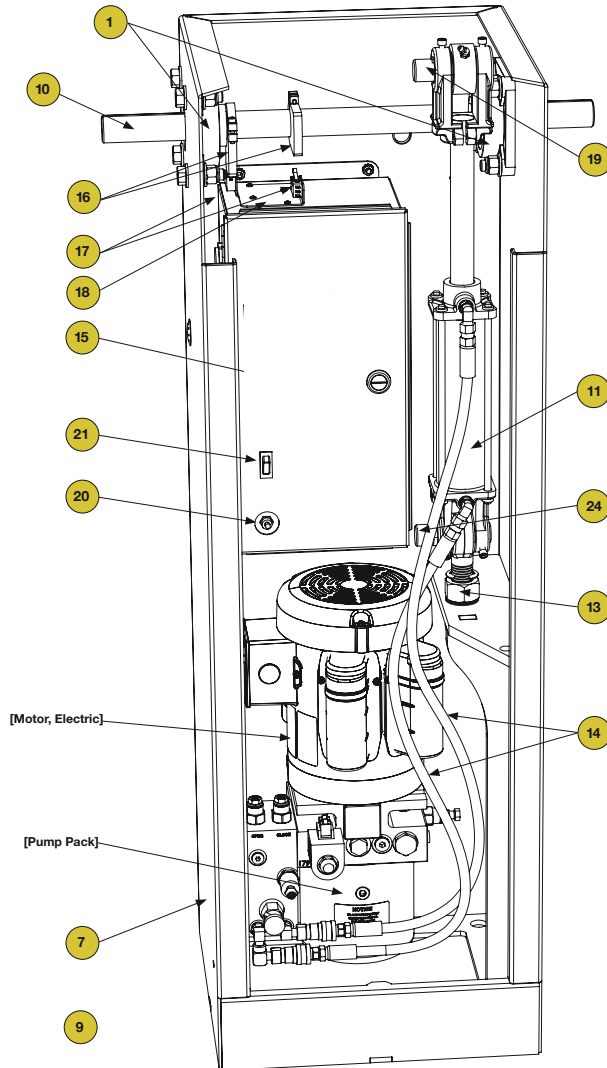

This drawing is a representation and should be used for parts reference only.

Item No.	Part Name	Part Number	StrongArm Models
1	Bearing, Crankshaft, 4 Bolt	MX000306	all
2	Board, Display	MX3356	all
3	Board, Power Supply, AC	MX000487	all AC
4	Board, Power Supply, DC	MX000369	all DC
5	Board, Smart Touch Controller	MX000585-0	all
6	Cable, Ribbon, LCD	MX000046	all
7	Chassis, Replacement	MX000497	all
8	Contactora, Motor	MX000485	all AC
Not shown	Cover, Replacement	MX000457	all
10	Crankshaft, Crank Bearing and Zerk	MX001100	all
11	Cylinder Kit	MX000077	all
12	Detector, Vehicle, Hy5B™	MX4621	all
13	Eyebolt, Nut and Nord-Lock, Cylinder Anchor	MX002467	all manufactured after 3/25/2011
14	Hose Kit, 2 Hoses	MX001386	all
15	Keypad, Smart Touch Controller	MX3399	all
16	Limit Cam	MX000299	all
17	Limit Switch	MX001777	all
18	Limit Switch Kit	MX001872	all
19	Pin, Cylinder, Stainless Steel	MX000312	all
20	Switch, Disconnect	MX000715	all
21	Switch, Hold Open	MX001240	all
22	Transformer, 24VAC Output, 75VA, 60/50Hz	MX001249	575VAC only
23	Transformer, 24VAC Output, 75VA, 60Hz	MX000486	all 60Hz AC except 575VAC
24	Pin, Cylinder, Stainless Steel	MX000312	all

StrongArm Diagrams

Chassis, Drive and Electrical

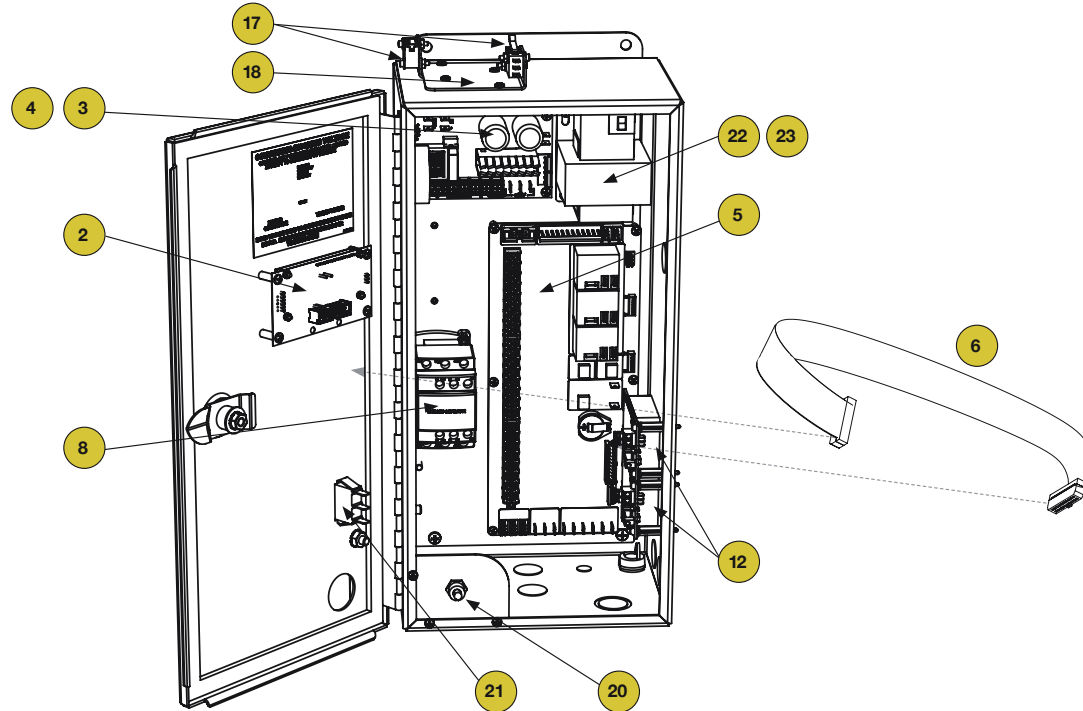

This drawing is a representation and should be used for parts reference only.

Item No.	Part Name	Part Number	StrongArm Models
1	Bearing, Crankshaft, 4 Bolt	MX000306	all
2	Board, Display	MX3356	all
3	Board, Power Supply, AC	MX000487	all AC
4	Board, Power Supply, DC	MX000369	all DC
5	Board, Smart Touch Controller	MX000585-0	all
6	Cable, Ribbon, LCD	MX000046	all
7	Chassis, Replacement	MX000497	all
8	Contactor, Motor	MX000485	all AC
Not shown	Cover, Replacement	MX000457	all
10	Crankshaft, Crank Bearing and Zerk	MX001100	all
11	Cylinder Kit	MX000077	all
12	Detector, Vehicle, Hy5B™	MX4621	all

Item No.	Part Name	Part Number	StrongArm Models
13	Eyebolt, Nut and Nord-Lock, Cylinder Anchor	MX002467	all manufactured after 3/25/2011
14	Hose Kit, 2 Hoses	MX001386	all
15	Keypad, Smart Touch Controller	MX3399	all
16	Limit Cam	MX000299	all
17	Limit Switch	MX001777	all
18	Limit Switch Kit	MX001872	all
19	Pin, Cylinder, Stainless Steel	MX000312	all
20	Switch, Disconnect	MX000715	all
21	Switch, Hold Open	MX001240	all
22	Transformer, 24VAC Output, 75VA, 60/50Hz	MX001249	575VAC only
23	Transformer, 24VAC Output, 75VA, 60Hz	MX000486	all 60Hz AC except 575VAC
24	Pin, Cylinder, Stainless Steel	MX000312	all

StrongArm Diagrams

Pump Pack

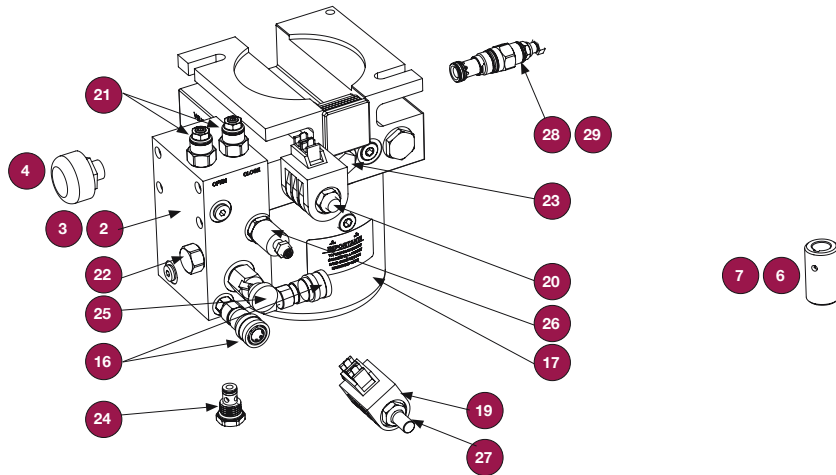

Item No.	Part Name	Part Number	StrongArm Models
1	AWOG, Face Down	MX000618	36 (HTG 320-8)
2	Brake Kit, Manifold, StrongArm 14F, 20, 28, DOT28	MX000146	all except 36 (HTG 320-8)
3	Brake Kit, Manifold, StrongArm 36	MX000235	36 (HTG 320-8)
4	Breather Cap	MX000686	all
5	Contactor, Mercury	MX001098	all DC
6	Coupler, Motor, 5/8 inch Shaft, 6T	MX002054	all*
7	Coupler, Motor, 5/8 inch Shaft, 9T, Old	MX001650	all*
8	Motor Start Switch Kit, 3/4 hp	MX3753	all AC 60Hz 1Ø
9	Motor, Electric, 24VDC, 3/4 hp	MX001646	all DC
10	Motor, Electric, 60Hz, 3/4 hp, 1Ø, 3450 RPM, 115/208/230VAC	MX001910	all 115/208/230VAC 60Hz 1Ø
11	Motor, Electric, 60Hz, 3/4 hp, 3Ø, 3450 RPM, 208/230/460VAC	MX001634	all 208/230/460VAC 60Hz 3Ø
12	Pump Pack, StrongArm 14F	MX001951	14F (HTG 320-2), 60Hz
13	Pump Pack, StrongArm 20	MX001952	20 (HTG 320-3), 60Hz
14	Pump Pack, StrongArm 28	MX001953	28 (HTG 320-6), 60Hz
15	Pump Pack, StrongArm 36	MX001954	36 (HTG 320-8), 60Hz
16	Quick Disconnect, Socket, 1/8 inch	MX000169	all
17	Reservoir, 2 Qt	MX000162	all
20	Valve, Directional, kit with matching coil	MX5245	all

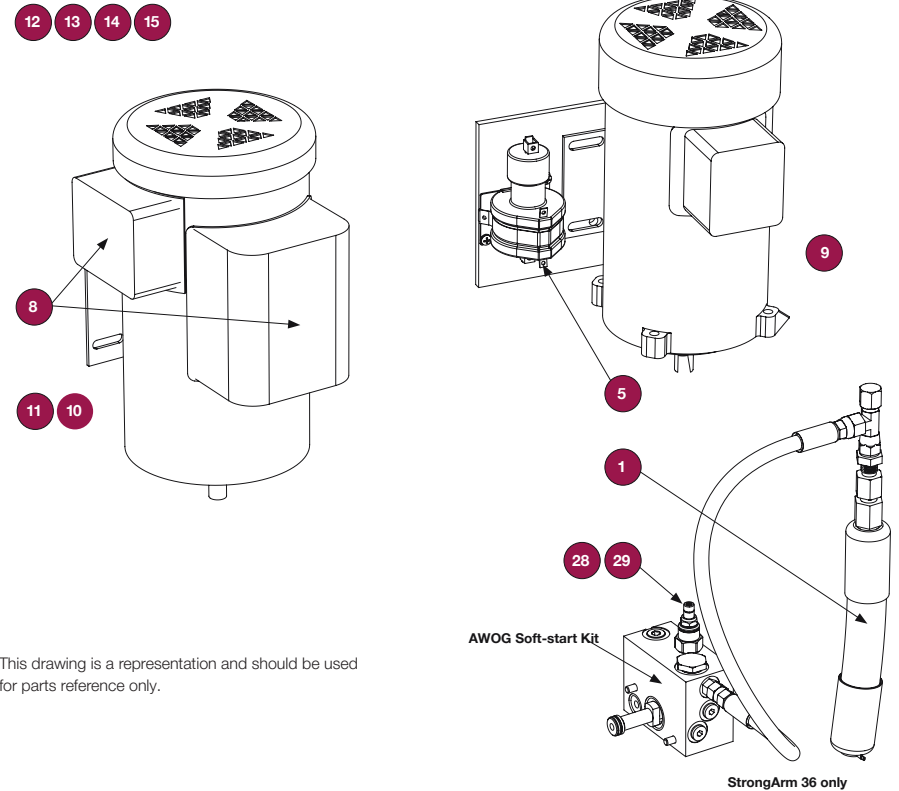

This drawing is a representation and should be used for parts reference only.

Item No.	Part Name	Part Number	StrongArm Models
21	Valve, Brake	MX000234	all
22	Valve, Check, Back-to-Back	MX000233	all
23	Valve, Check, Endhead Main	MX000171	all
24	Valve, Check, Manifold	MX000229	all
25	Valve, Manual Bypass	MX000230	all except 36 (HTG 320-8)
26	Valve, Manual Bypass Flow Control, 3500 PSI	MX000231	all
27	Valve, Manual Bypass/Quick Stop, kit with matching coil	MX5274	36 (HTG 320-8)
28	Valve, Relief, 1500 PSI	MX000658	all except 36 (HTG 320-8)
29	Valve, Relief, Soft-Start Operators	MX000659	36 (HTG 320-8)

Call for 50Hz motors and pump packs

* Use MX002054 for operators manufactured after 6/1/2009, MX001650 for operators with pump packs manufactured before 6/1/2009.

SlideDriver II Diagrams

Electrical components, all models

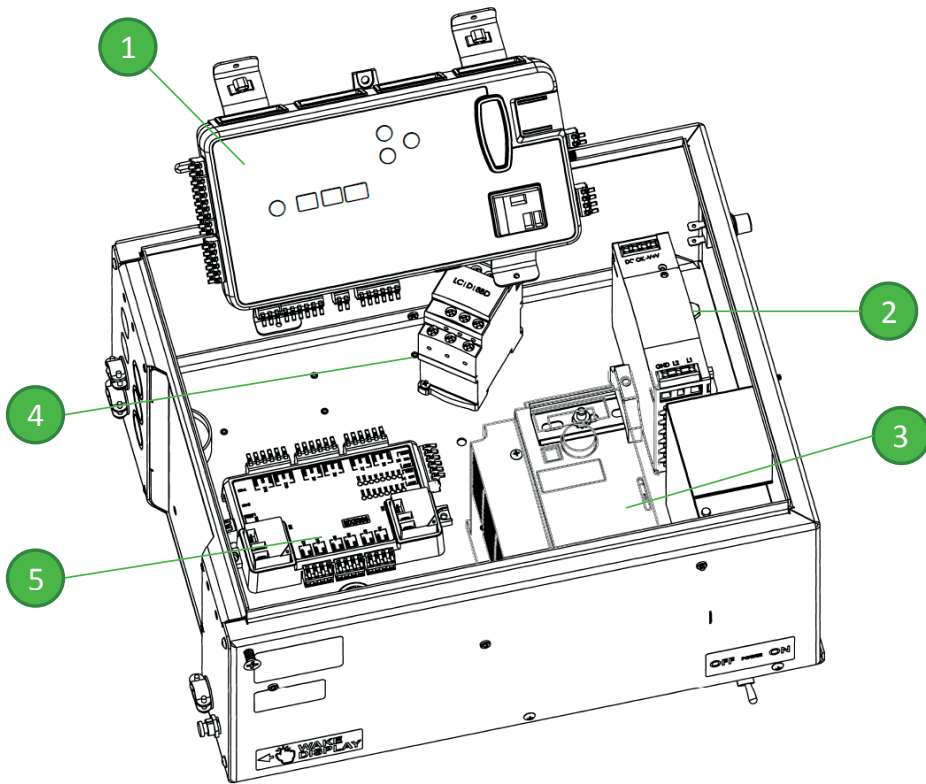

This drawing is a representation and should be used for parts reference only.

Item No.	Part Number	Description	SD15	SD40	SD50F	SD80V	SD200V
1	MX5822	SmartTouch 725 Controller	x	x	x	x	x
	MX5846	SmartTouch 720 Controller	*	*	*	*	*
2	MX4097	Power Supply, 120W 24VDC (SD15 and SD40 30 \square All VFD)	x	x	x	x	x
	MX5106	Power Supply, 120W, 24VDC (1 \square input power)	x	x	-	-	-
3	MX5495	Variable Frequency Drive, 2HP. Three phase input voltage 200-240 VAC 50/60Hz.			x	x	
	MX5494	Variable Frequency Drive, 2HP. Single phase input voltage 200-240 VAC 50/60Hz.			x	x	
	MX5496	Variable Frequency Drive, 2HP. Three phase input voltage 400-480 VAC 50/60Hz.			x	x	
	MX5497	Variable Frequency Drive, 5HP. Three phase input voltage 200-240 VAC 50/60Hz.					x
	MX5498	Variable Frequency Drive, 5HP. Three phase input voltage 200-240 VAC 50/60Hz.					x
4	MX4105	Contactor, AC Motor	x	x	*	*	*
5	MX5823	I/O Expansion Module	x	x	Option	Option	Option

* This part is included with installed options for heaters, solenoid rail locks, or corrections upgrades.

SlideDriver II Diagrams

Motor and Pump Pack

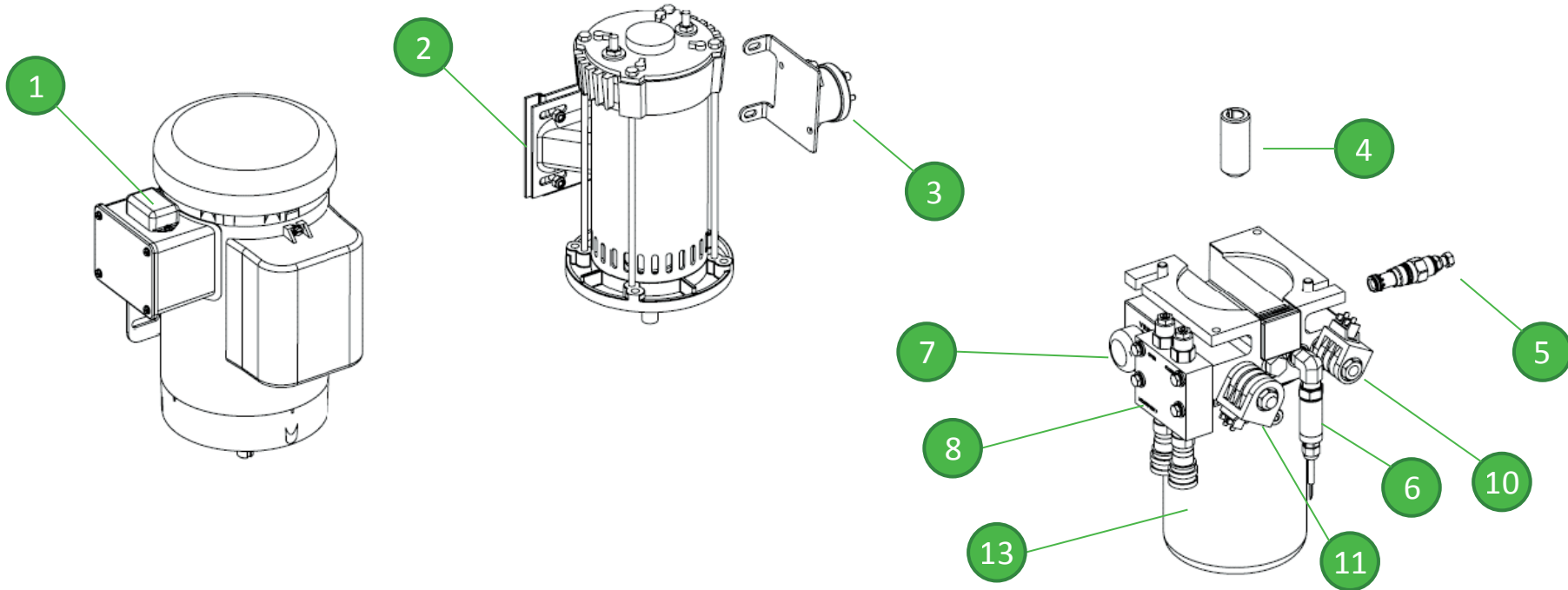

This drawing is a representation and should be used for parts reference only.

Item No.	Part Number	Description	SD15	SD40	SD50F	SD80V	SD200V
1	MX001911	Motor, Electric, 60Hz, 1 hp, 1Ø, 3450 RPM, 115/208/230VAC	x	x	-	-	-
	MX001636	Motor, Electric, 60Hz, 1 hp, 3Ø, 3450 RPM, 208/230/460VAC	x	x	-	-	-
	MX001638	Motor, Electric, 60Hz, 2 hp, 3Ø, 3450 RPM, 208/230/460VAC	-	-	x	x	-
	MX001639	Motor, Electric, 60Hz, 5 hp, 3Ø, 3450 RPM, 208/230/460VAC	-	-	-	-	x
2	MX001647	Motor, Electric, 24VDC, 2 hp	-	x	-	-	-
	MX001648	Motor, Electric, 24VDC, 4 hp	-	-	-	-	x
3	MX5192-02	Contact, Solenoid, 24VDC (SD40 DC)	-	x	-	-	-

Item No.	Part Number	Description	SD15	SD40	SD50F	SD80V	SD200V
4	MX002054	Coupler, 5/8 inch shaft, 6T	x	x	x	x	x
5	MX000174	Valve, Relief, 3000PSI	x	x	x	x	x
6	MX5502	Transducer, Pressure, 3000 PSI	x	x	x	x	x
7	MX000686	Breather Cap	x	x	x	x	x
8	MX000143	Brake Kit	-	x	x	x	x
10	MX5246	Valve, Unloader Kit	x	x	-	-	-
11	MX5245	Valve, Directional Kit	x	x	x	x	x
13	MX000161	Reservoir, 4 Qt	x	x	x	x	x

SlideDriver II Diagrams

SlideDriver II SD200V

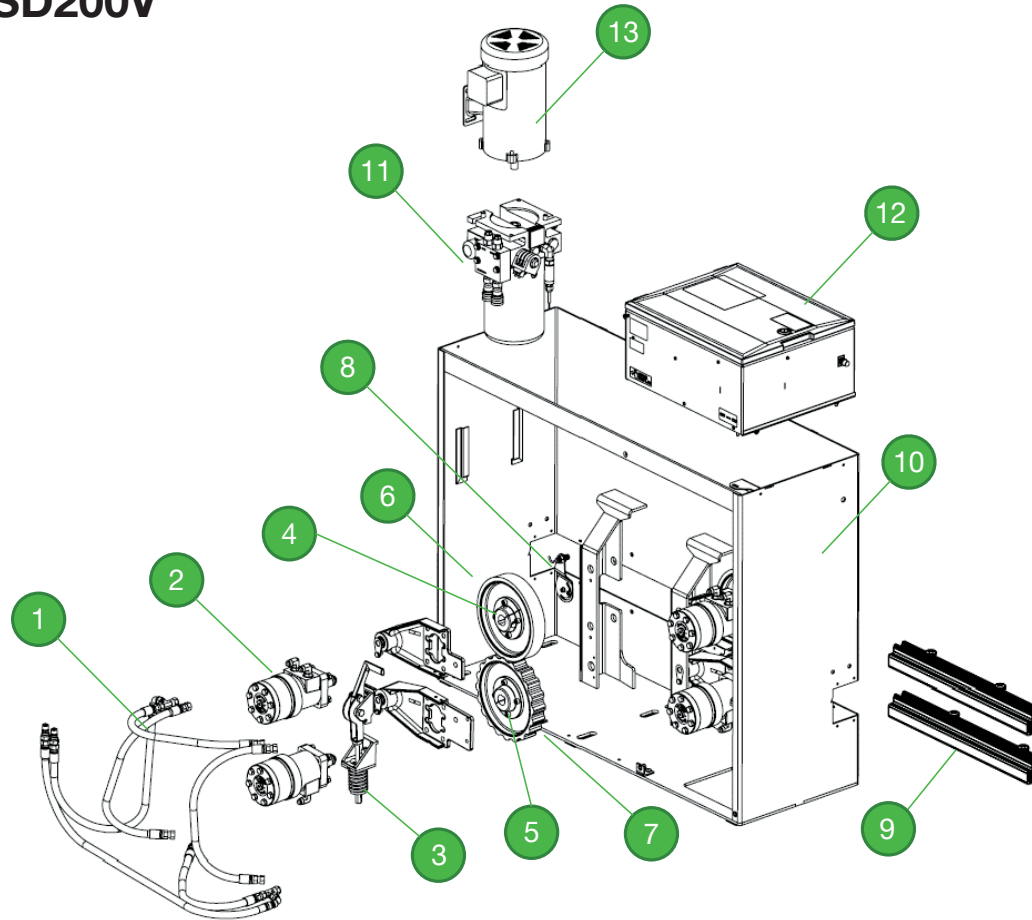

This drawing is a representation and should be used for parts reference only.

item No.	Part Number	Description	SD200V
1	MX4578	Hose Kit Replacement	x
2	MX4848	Motor, Hydraulic, 12 inch	x
3	MX001103	Release, Manual, Toggle Assy	x
4	MX3132	8 inch AdvanceDrive wheel kit, including hub, lug nuts, and mounting hardware.	x
5	MX5350	8 inch XtremeDrive wheel kit, including hub, lug nuts, and attachment hardware.	x
6	MX5223	Wheel Kit. Replacement, 8 inch. Includes lug nuts.	x
7	MX5352	XtremeDrive Wheel, 8 inch. Includes lug nuts.	x

item No.	Part Number	Description	SD200V
8	MX5493	Limit Sensor Assy	x
9	MX5492	Limit Kit, Stop Indicator	x
10	MX5532-XX	Chassis, Replacement, SlideDriver II	x
11	MX5536	Pump Pack, SlideDriver II, SD50F and SD80V	x
12	MX5504	Cover, Electrical Enclosure (not shown)	x
13	-	Motor, Electric	See "Motor and Pump Pack" on page 51

SlideDriver II Diagrams

Motor and Pump Pack

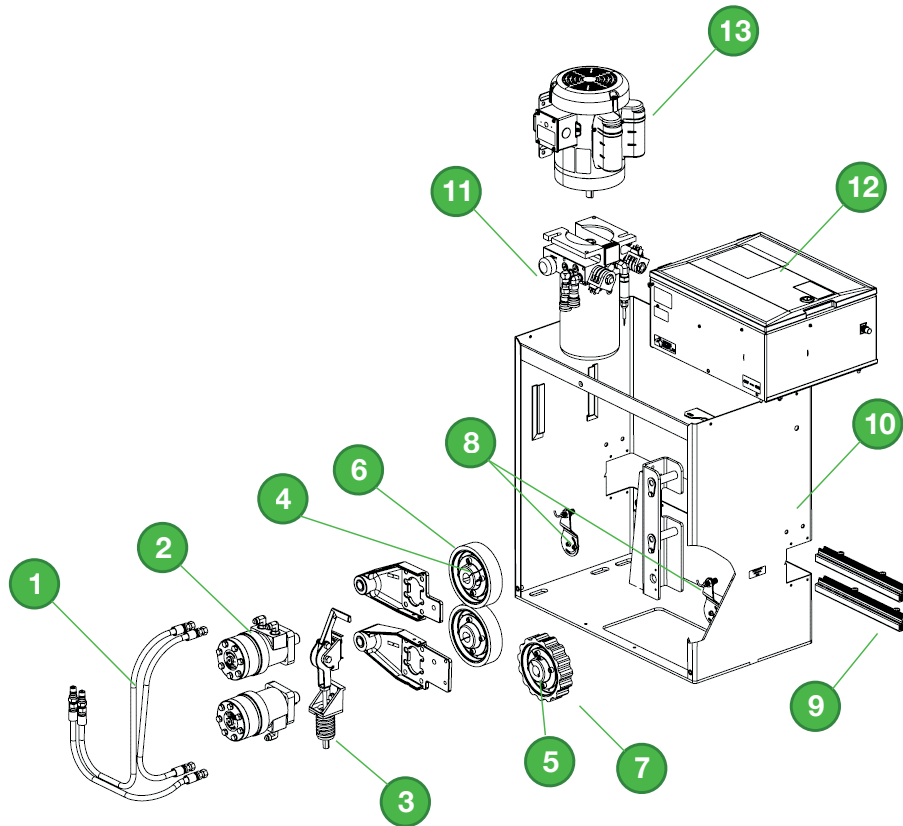

This drawing is a representation and should be used for parts reference only.

ITEM NO.	PART NUMBER	DESCRIPTION	SD15	SD40	SD50F	SD80V
1	MX5503	Hose Kit, 3/8 inch w/QD, 3 lengths	x	x	x	x
2	MX4752	Motor, Hydraulic, 10 inch	x	x	x	
	MX4849	Motor, Hydraulic, 24 inch				x
3	MX001103	Release, Manual, Toggle Assy	x	x	x	x

ITEM NO.	PART NUMBER	DESCRIPTION	SD15	SD40	SD50F	SD80V
4	MX002707	6 inch diameter AdvanceDrive Wheel, hub, lug nuts, and mounting hardware.	x	x		
	MX3132	8 inch AdvanceDrive wheel kit, including hub, lug nuts, and mounting hardware.			x	x
5	MX5349	6 inch diameter XtremeDrive wheel kit, including hub, lug nuts, and attachment hardware	x	x		
	MX5350	8 inch XtremeDrive wheel kit, including hub, lug nuts, and attachment hardware.			x	x
6	MX4994	Wheel Kit, Replacement, 6 inch	x	x		
	MX5223	Wheel Kit, Replacement, 8 inch			x	x
7	MX5349	XtremeDrive Wheel, 6 inch	x	x		
	MX5352	XtremeDrive Wheel, 8 inch			x	x
8	MX5493	Limit Sensor Assy	x	x	x	x
9	MX5492	Limit Kit, Stop Indicator	x	x		x
	MX5491	Limit kit, SlideDriver II SD50F			x	
10	MX5533XX	Chassis, Replacement, SlideDriver II	x	x	x	x
11	MX5499	Pump Pack, SlideDriver II, SD15	x			
	MX5535	Pump Pack, SlideDriver II SD 40		x		
	MX5536	Pump Pack, SlideDriver II SD50F, SD80V, SD200			x	x
12	MX5504	Cover, Electrical Enclosure (not shown)	x	x	x	x
13	-	Motor, Electric	See table page 51			

HydraSwing Diagrams

HydraSwing 40/40F Actuator

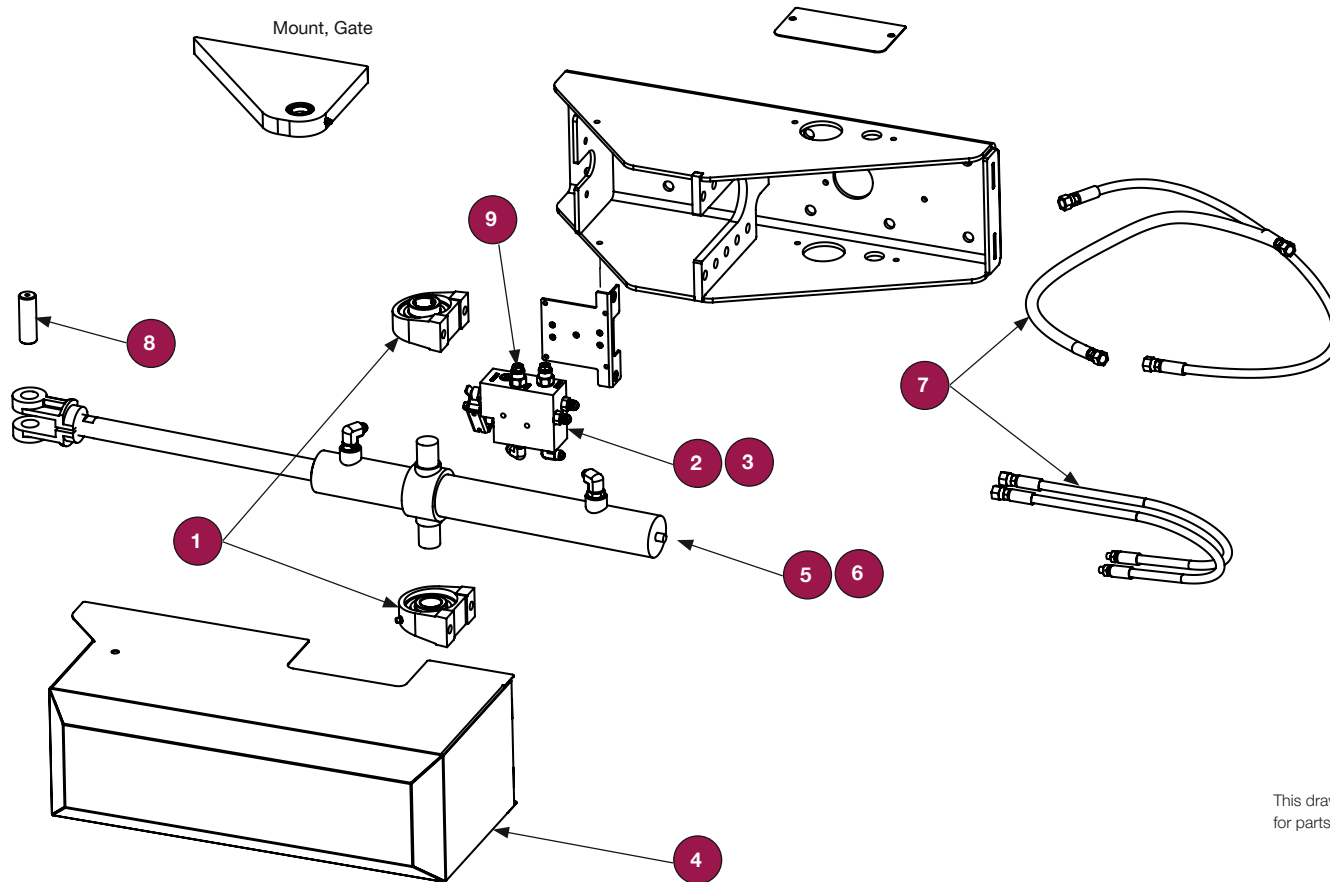
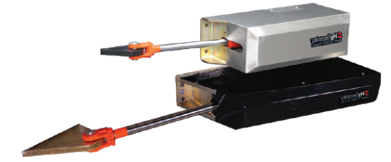

This drawing is a representation and should be used for parts reference only.

Item No.	Part Name	Part Number	HydraSwing Models (current)
1	Bearing, Tapped, 1.25 inch	MX000770	all
2	Brake Manifold Assembly, HydraSwing 40/40F/40 Twin LH	MX3261-02	40/40F/40 Twin LH
3	Brake Manifold Assembly, HydraSwing 40/40F/40 Twin RH	MX3261-01	40/40F/40 Twin RH
4	Cover, Chassis, Standard, HydraSwing 40/40F	MX3531-04	all
5	Cylinder Kit, Position Sensing, 40/40F/40 Twin	MX3546	40/40F/40 Twin (Primary)

Item No.	Part Name	Part Number	HydraSwing Models (current)
6	Cylinder Kit, without Sensor, 40/40F/40 Twin	MX3547	40/40F Twin (Secondary)
7	Hose Kit with Fittings, HydraSwing 40/40F	MX3545	all
8	Pin, Cylinder	MX3058	all
9	Valve, Brake	MX000234	all

HydraSwing Diagrams

HydraSwing 80F/150 Actuator

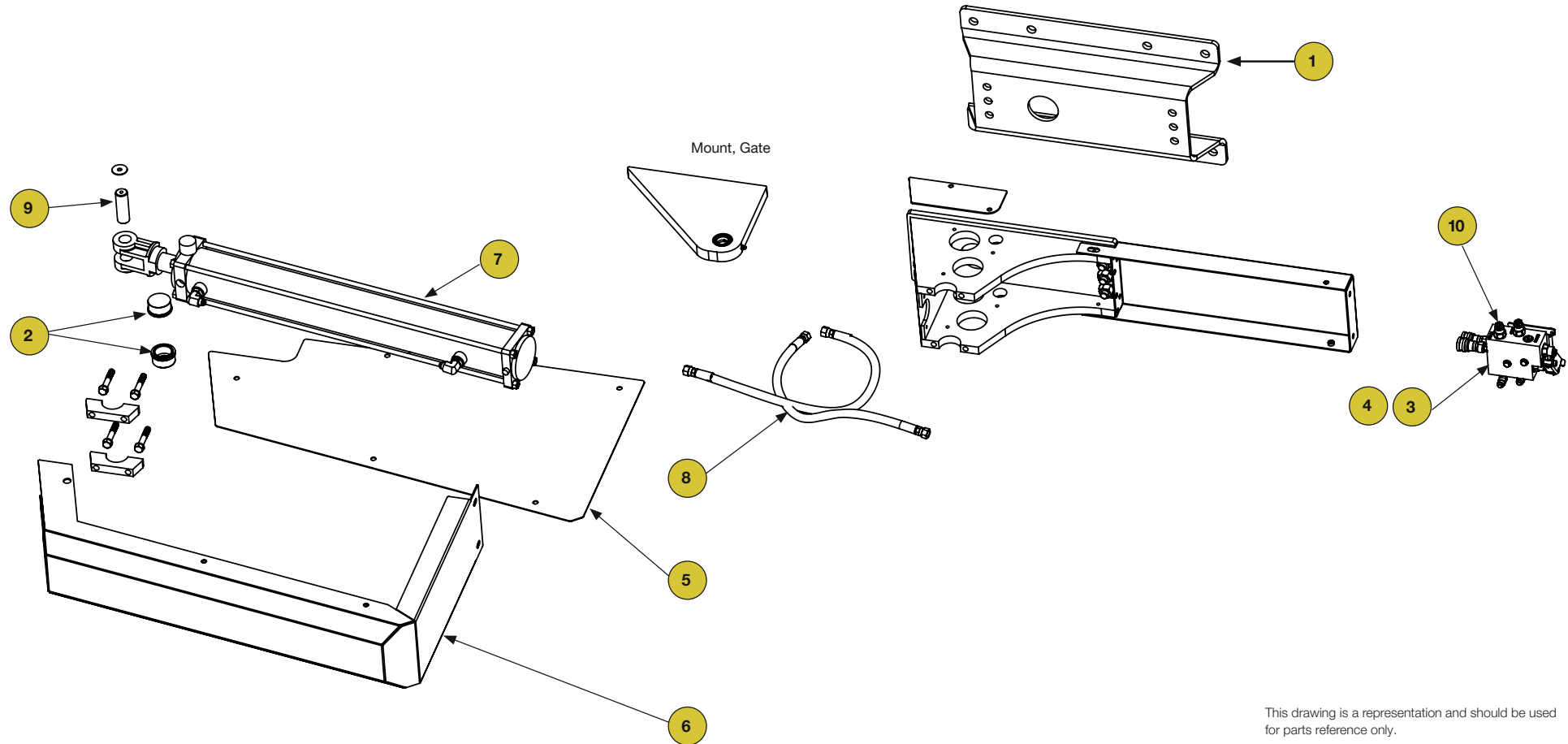
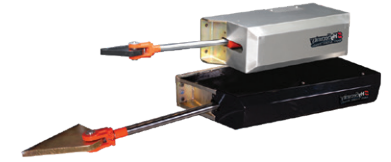

This drawing is a representation and should be used for parts reference only.

item no.	Part Name	Part Number	HydraSwing Models (current)
1	Base Extension, HydraSwing 80F/150	MX3225-02	all
2	Bearing, Cup, HydraSwing 80F/150	MX3224	all
3	Brake Manifold Assembly, HydraSwing 80F/150 LH	MX3317-02	80F/150 LH
4	Brake Manifold Assembly, HydraSwing 80F/150 RH	MX3317-01	80F/150 RH
5	Cover, Chassis, HydraSwing 80F/150	MX3069-02	all

item no.	Part Name	Part Number	HydraSwing Models (current)
6	Cover, Front, HydraSwing 80F/150	MX3532-02	all
7	Cylinder Assembly w/Fittings, HydraSwing 80F/150	MX3548	all
8	Hose Kit, HydraSwing 80F/150	MX3062	all
9	Pin, Cylinder	MX3058	all
10	Valve, Brake	MX000234	all

HydraSwing Diagrams

Pump Pack

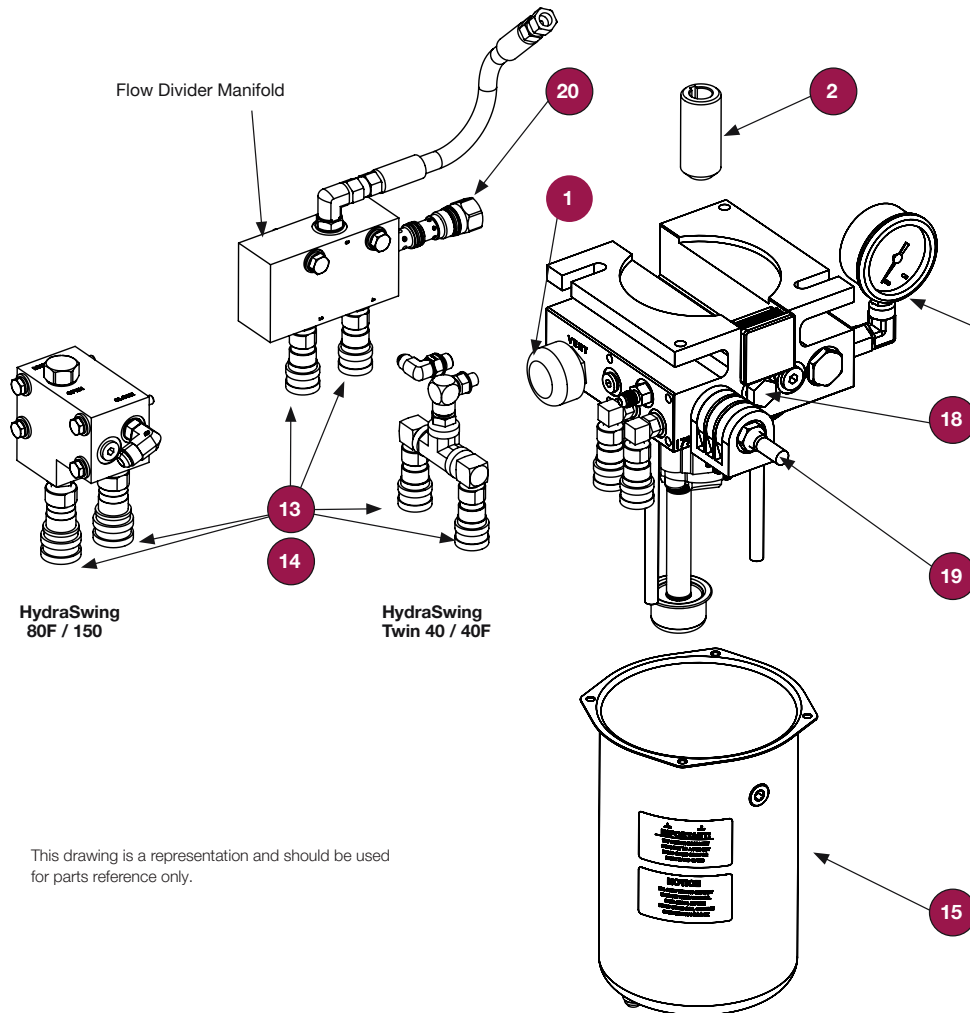

- 5
- 6
- 7
- 8
- 9
- 10

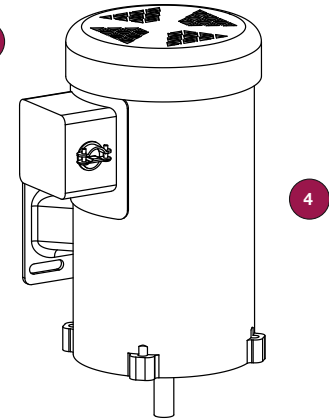

This drawing is a representation and should be used for parts reference only.

Item No	Part Name	Part Number	HydraSwing Single Models (current)
1	Breather Cap	MX000686	all
2	Coupler, Motor, 5/8 inch Shaft, 6T	MX002054	all
3	Gauge, Pressure, 3000 PSI, Kit	MX001107	all

Item No	Part Name	Part Number	HydraSwing Single Models (current)
4	Motor, Electric, 60Hz, 2 hp, 3Ø, 3450 RPM, 208-230/460VAC	MX001638	all
5	Pump Pack, HydraSwing 150	MX3523	150
6	Pump Pack, HydraSwing 40	MX3520	40
7	Pump Pack, HydraSwing 40 Twin	MX3524	40 Twin
8	Pump Pack, HydraSwing 40F	MX3521	40F
9	Pump Pack, HydraSwing 40F Twin	MX3525	40F Twin
10	Pump Pack, HydraSwing 80F	MX3522	80F
11	Quick Disconnect, Plug, 1/4 inch	MX000202	80F/150
12	Quick Disconnect, Plug, 1/8 inch	MX000170	40/40F
13	Quick Disconnect, Socket, 1/4 inch	MX000201	80F/150
14	Quick Disconnect, Socket, 1/8 inch	MX000169	40/40F
15	Reservoir, 4 Qt	MX3475	all
16	Sensor Kit, Inherent Entrapment	MX000091	all
18	Valve, Check, Endhead Main	MX000171	all
19	Valve, Directional, Manual, Kit with matching coil	MX5259	all
20	Valve, Flow Divider	MX000993	40/40F Twin
21	Valve, Relief, 1500 PSI	MX000658	all

HydraSwing Diagrams

HydraSupply, Electrical

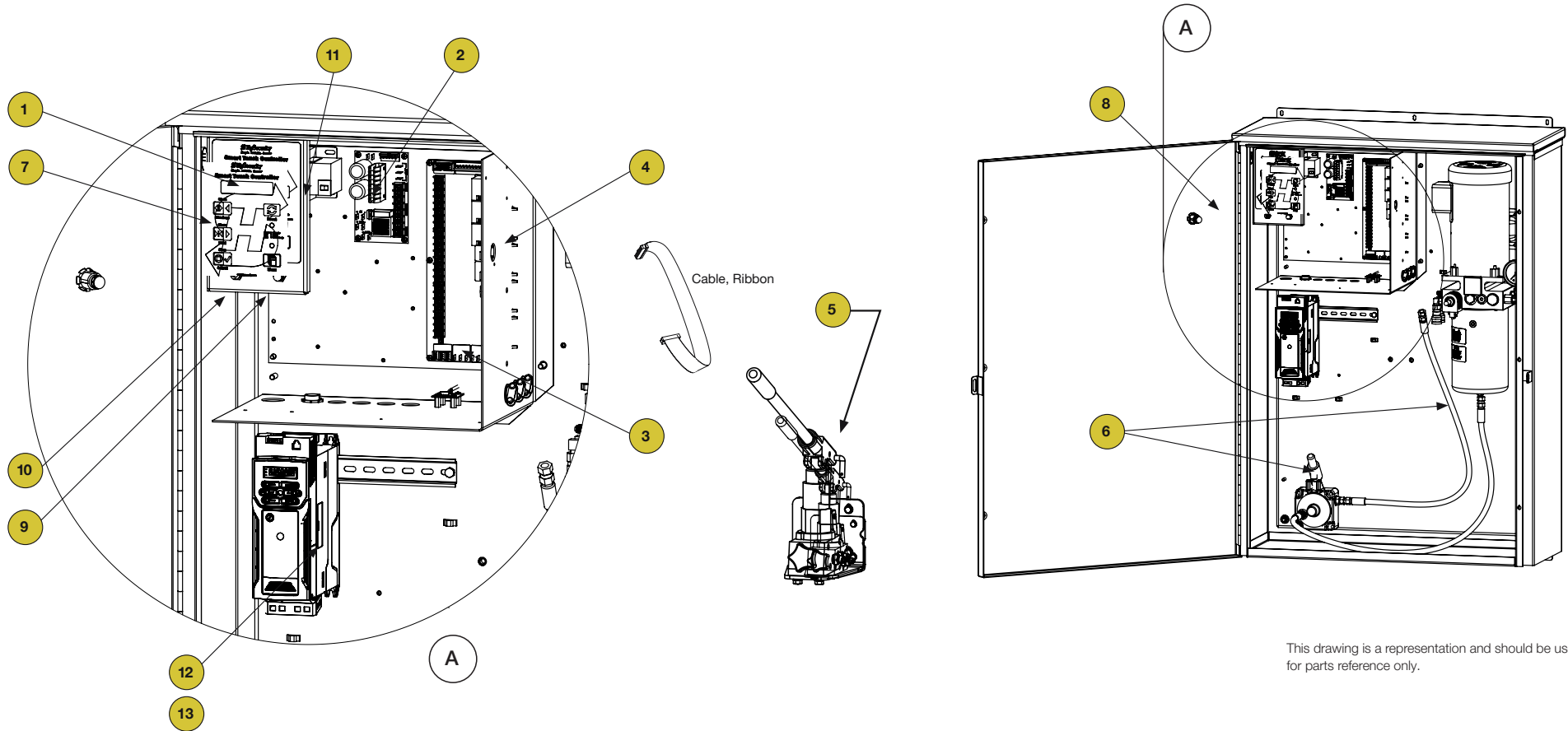
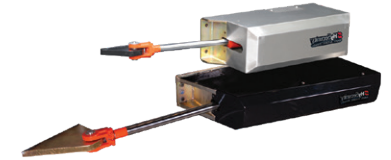

This drawing is a representation and should be used for parts reference only.

Item No.	Part Name	Part Number	HydraSwing Models (current)
1	Board, Display	MX3356	all
2	Board, Power Supply, AC	MX000487	all AC
3	Board, Smart Touch Controller	MX000585-0	all
4	Detector, Vehicle, Hy5B™	MX4621	all
5	Hand Pump Assembly, HydraSwing 80F/150	MX3549	80F/150
6	Hand Pump, Replacement Kit	MX001306	40/40F/40 Twin
7	Keypad, Smart Touch Controller	MX3399	all

Item No.	Part Name	Part Number	HydraSwing Models (current)
8	Reset Button, External	MX001216	all
9	Reset Switch, Internal	MX002124	all
10	Switch, Disconnect	MX000715	all
11	Transformer, 24VAC Output, 75VA, 60Hz	MX000486	all 60Hz AC except 575VAC
12	Variable Frequency Drive Unit (VFD), Modbus, 208-230VAC, 50/60Hz, 1Ø/3Ø	MX4210	all 208,220,230VAC 50/60Hz input
13	Variable Frequency Drive Unit (VFD), Modbus, 380-460VAC, 50/60Hz, 3Ø	MX4211	all 380,460VAC 50/60Hz input

SwingRiser Diagrams

Post (typical)

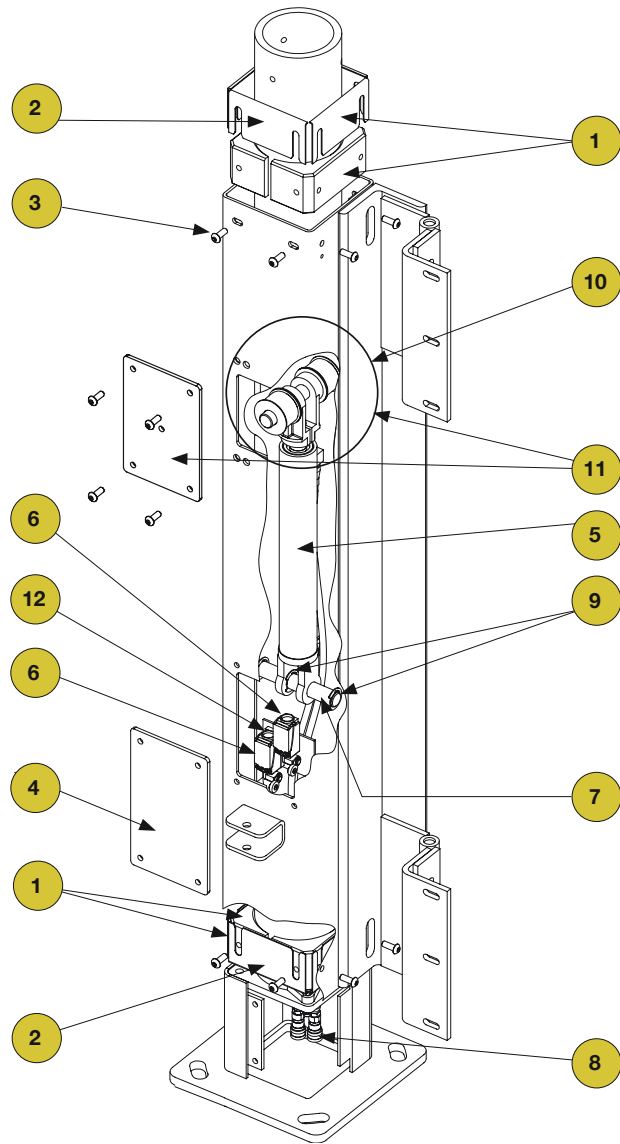

This drawing is a representation and should be used for parts reference only.

Item No.	Part Name	Part Number	SwingRiser Models
1	Bearing and Shim Kit, Upper & Lower	MX001718	all since 2005, contact HySecurity for pre-2005 Post
2	Bearing Shim Kit, Shims only	MX002057	all since 2005, contact HySecurity for pre-2005 Post
3	Bolt, Button Head, 3/8 inch, Nickel Plated	MX001089	all
4	Cover Plate, Lower	MX000531	all
5	Cylinder Kit, Long Hoses	MX001101	all
6	Limit Switch	MX000866	all
7	Pin, Lower Cylinder	MX000542	all
8	Quick Disconnect, Socket, 1/8 inch	MX000169	all
9	Retaining Ring, 1 inch	MX000768	all
10	Shaft Kit, 1 inch Roller	MX001221	all
11	Shaft Kit, 1 inch Roller Upgrade	MX001220	all
12	Spacer, Lower Limit Switch	MX000541	all

SwingRiser Diagrams

Pump Pack, Single (HRG 220)

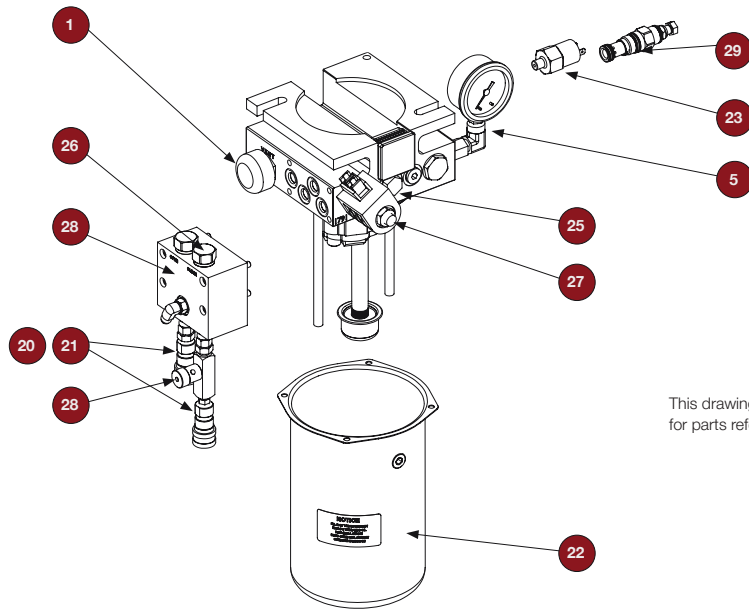

This drawing is a representation and should be used for parts reference only.

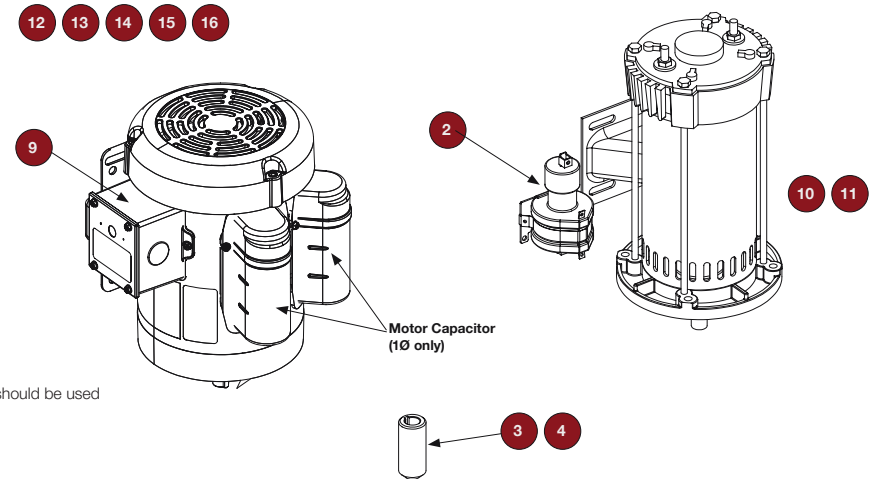

Item No.	Part Name	Part Number	SwingRiser Single (HRG 220) Models
1	Breather Cap	MX000686	all
2	Contactora, Mercury	MX001098	all DC
3	Coupler, Motor, 5/8 inch Shaft, 6T	MX002054	all*
4	Coupler, Motor, 5/8 inch Shaft, 9T, Old	MX001650	all*
5	Gauge, Pressure, 3000 PSI, Kit	MX001107	all
6	Hose Fittings Kit, 1/4 inch, Single	MX001132	see replacement parts listing for ordering information
7	Hose, 1/4 inch	MX001114	see replacement parts listing for ordering information
8	Manifold, Flow Control, SwingRiser Single	MX001127	all
9	Motor Start Switch, 3/4 hp, 1 hp and 2 hp	MX3402	all AC 60Hz 1Ø
10	Motor, Electric, 24VDC, 2 hp	MX001647	14 (HRG 220-A) 24VDC
11	Motor, Electric, 24VDC, 3/4 hp	MX001646	19, 30 (HRG 220-B, 220-C) 24VDC
12	Motor, Electric, 60Hz, 1 hp, 1Ø, 1725 RPM, 115/208-230VAC	MX001640	19, 30 (HRG 220-B, 220-C) 115/208/230VAC 60Hz 1Ø
13	Motor, Electric, 60Hz, 1 hp, 1Ø, 3450 RPM, 115/208/230VAC	MX001911	14 (HRG 220-A) 115/208/230VAC 60Hz 1Ø

Item No.	Part Name	Part Number	SwingRiser Single (HRG 220) Models
14	Motor, Electric, 60Hz, 1 hp, 3Ø, 1725 RPM, 208-230/460VAC	MX001641	19, 30 (HRG 220-B, 220-C) 208/230/460VAC 60Hz 3Ø
15	Motor, Electric, 60Hz, 1 hp, 3Ø, 3450 RPM, 208-230/460VAC	MX001636	14 (HRG 220-A) 208/230/460VAC 60Hz 3Ø
16	Motor, Electric, 60Hz, 1 hp, 3Ø, 3450 RPM, 575VAC	MX001667	14 (HRG 220-A) 575VAC
17	Pump Pack, SwingRiser 14	MX001959	14 (HRG 220-A) 60Hz
18	Pump Pack, SwingRiser 19	MX001960	19 (HRG 220-B) 60Hz
19	Pump Pack, SwingRiser 30	MX001961	30 (HRG 220-C) 60Hz
20	Quick Disconnect, Plug, 1/8 inch	MX000170	all
21	Quick Disconnect, Socket, 1/8 inch	MX000169	all
22	Reservoir, 4 Qt	MX001416	all
23	Sensor Kit, Inherent Entrapment	MX000091	all
25	Valve, Check, Endhead Main	MX000171	all
26	Valve, Check, Manifold	MX000352	all
27	Valve, Directional, Manual, Kit with matching coil	MX5259	all
28	Valve, Flow Control	MX001258	all
29	Valve, Relief, 3000 PSI	MX000174	all

Call for 50Hz motors and pump packs

* Use MX002054 for operators manufactured after 6/1/2009, MX001650 for operators with pump packs manufactured before 6/1/2009.

SwingRiser Diagrams

Pump Pack, Twin (HRG 222)

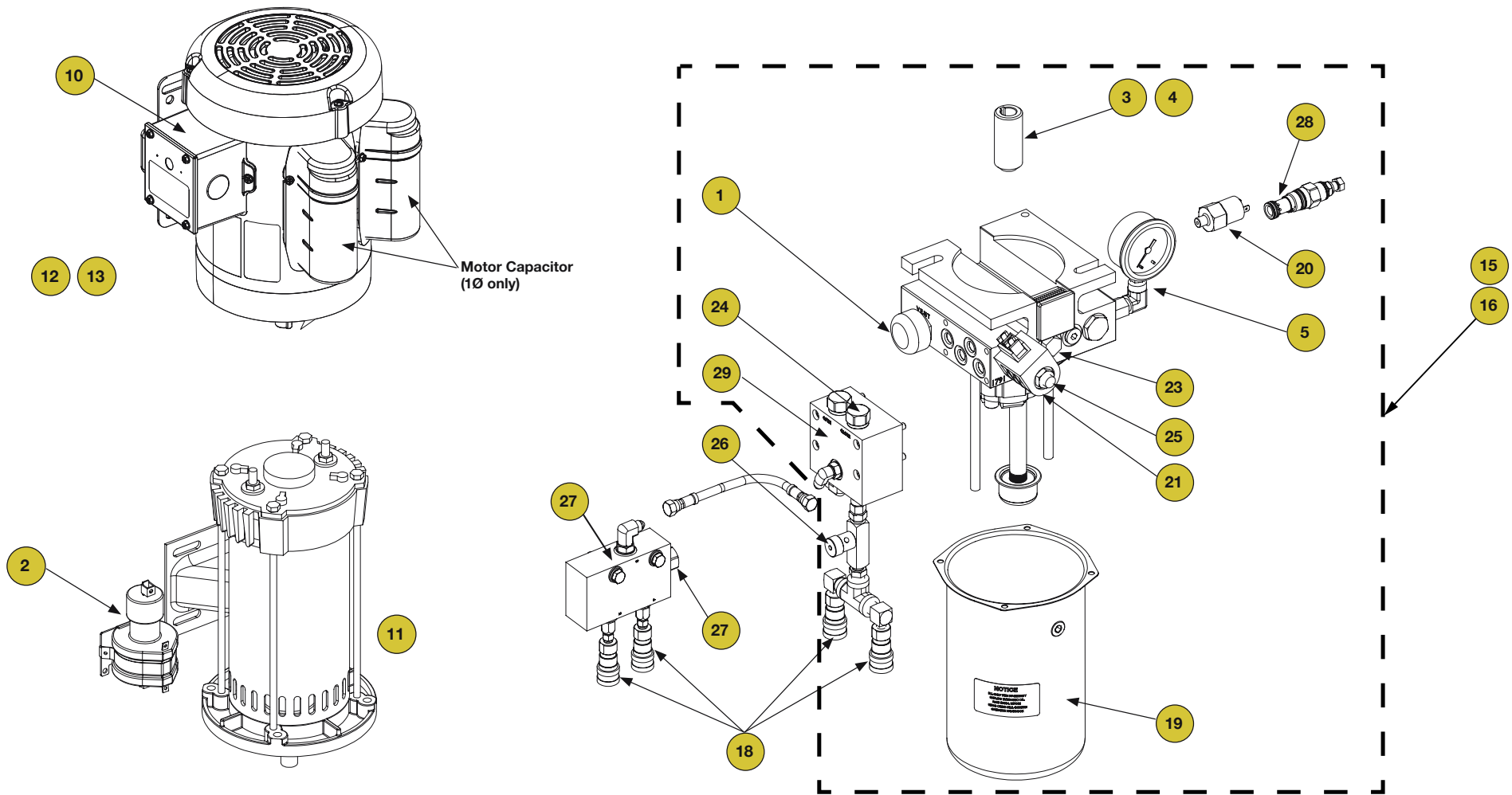

This drawing is a representation and should be used for parts reference only.

SwingRiser Diagrams

Pump Pack, Twin (HRG 222)



Item No.	Part Name	Part Number	SwingRiser Twin (HRG 222) Models
1	Breather Cap	MX000686	all
2	Contactora, Mercury	MX001098	all DC
3	Coupler, Motor, 5/8 inch Shaft, 6T	MX002054	all*
4	Coupler, Motor, 5/8 inch Shaft, 9T, Old	MX001650	all*
5	Gauge, Pressure, 3000 PSI, Kit	MX001107	all
6	Hose Fitting Kit, 1/4 inch, Twin (Not Shown)	MX001135	See HySecurity Hose Order Form
7	Hose, 1/4 inch (Not Shown)	MX001114	See HySecurity Hose Order Form
8	Manifold, Flow Control, SwingRiser Twin	MX001128	all
9	Manifold, Flow Divider, SwingRiser Twin	MX001861	all
10	Motor Start Switch, 3/4 hp, 1 hp and 2 hp	MX3402	all AC 60Hz 1Ø
11	Motor, Electric, 24VDC, 2 hp	MX001647	14 Twin, 19 Twin, 30 Twin (HRG 222-A, 222-B, 222-C) 24VDC
12	Motor, Electric, 60Hz, 2 hp, 1Ø, 3450 RPM, 208/230VAC	MX001912	14 Twin, 19 Twin, 30 Twin (HRG 222-A, 222-B, 222-C) 208/230VAC 60Hz 1Ø
13	Motor, Electric, 60Hz, 2 hp, 3Ø, 3450 RPM, 208-230/460VAC	MX001638	14 Twin, 19 Twin, 30 Twin (HRG 222-A, 222-B, 222-C) 208/230/460VAC
14	Pump Pack, SwingRiser 14 Twin	MX001965	14 Twin (HRG 222-A) 60Hz and DC
15	Pump Pack, SwingRiser 19 Twin	MX001966	19 Twin (HRG 222-B) 60Hz and DC

Item No.	Part Name	Part Number	SwingRiser Twin (HRG 222) Models
16	Pump Pack, SwingRiser 30 Twin	MX001967	30 Twin (HRG 222-C) 60Hz and DC
17	Quick Disconnect, Socket, 1/8 inch (Not Shown)	MX000170	all
18	Quick Disconnect, Socket, 1/8 inch	MX000169	all
19	Reservoir, 4 Qt	MX001416	all
20	Sensor Kit, Inherent Entrapment	MX000091	all
21	Valve Coil, Directional, 24VDC	MX000184	all
23	Valve, Check, Endhead Main	MX000171	all
24	Valve, Check, Manifold	MX000352	all
25	Valve, Directional, Manual, Kit with matching coil	MX5259	all
26	Valve, Flow Control	MX001258	all
27	Valve, Flow Divider	MX001833	all
28	Valve, Relief, 3000 PSI	MX000174	all
29	Manifold Assembly	MX001127	all

Call for 50Hz motors and pump packs

* Use MX002054 for operators manufactured after 6/1/2009, MX001098 for operators with pump packs manufactured before 6/1/2009.

SwingRiser Diagrams

HydraSupply, Electrical

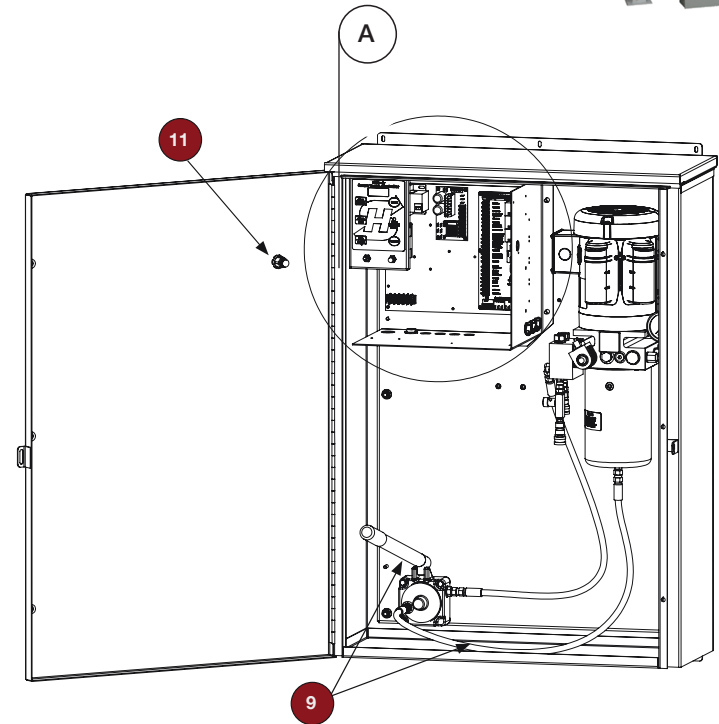
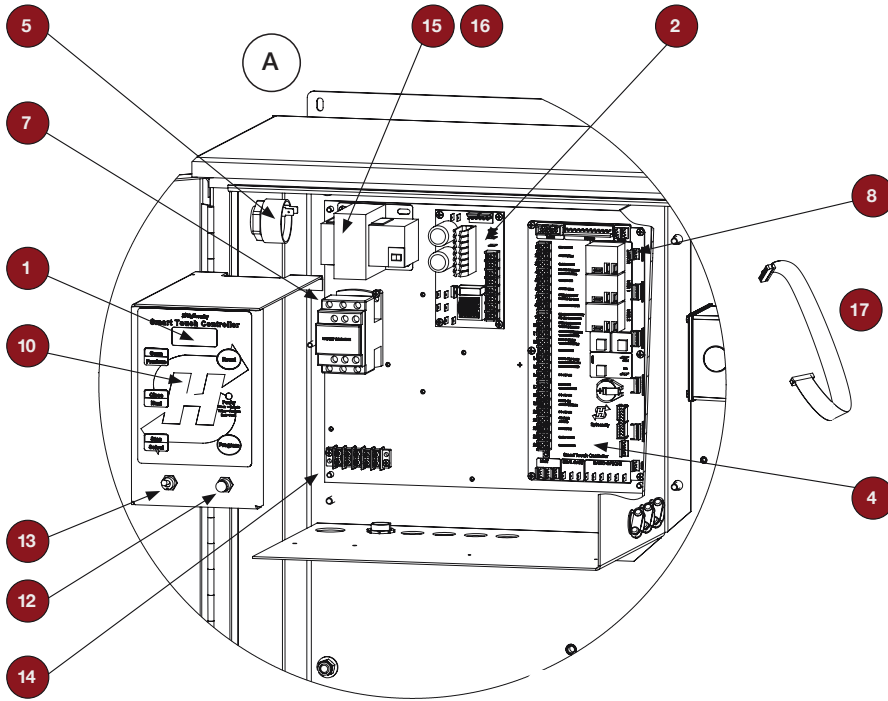

This drawing is a representation and should be used for parts reference only.

Item No.	Part Name	Part Number	SwingRiser Models
1	Board, Display	MX3356	all
2	Board, Power Supply, AC	MX000487	all AC
3	Board, Power Supply, DC	MX000369	all DC
4	Board, Smart Touch	MX000585	all
5	Buzzer, Piezo	MX001036	all
6	Cable, Ribbon, LCD	MX000046	all
7	Contact, Motor	MX000485	all AC
8	Detector, Vehicle, Hy5B™	MX4621	all
9	Hand Pump, Replacement Kit	MX001306	all

Item No.	Part Name	Part Number	SwingRiser Models
10	Keypad, Smart Touch Controller	MX3399	all
11	Reset Button, External	MX001216	all
12	Reset Switch, Internal	MX002124	all
13	Switch, Disconnect	MX000715	all
14	Terminal Block, 5-Pole	MX001270	all
15	Transformer, 24VAC Output, 75VA, 60/50Hz	MX001249	575VAC only
16	Transformer, 24VAC Output, 75VA, 60Hz	MX000486	all 60Hz AC except 575VAC
17	Cable, Ribon, Display	MX000046	all

AC and DC Power Supply Diagrams

AC Power Supply with HyInverter AC

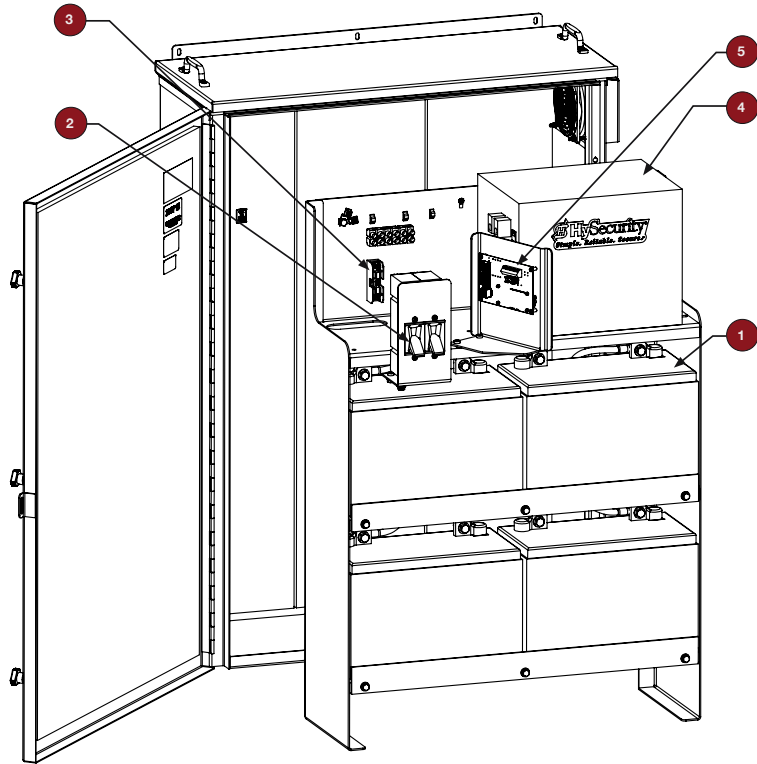

This drawing is a representation and should be used for parts reference only.

AC Power Supply with HyInverter AC

Item No.	Part Name	Part Number
1	Battery, 12V, 110AH, AGM	MX000877
2	Dual Breaker, Battery Disconnect	MX3849
3	Fuse, 250V, 20A	MX002897
4	Inverter Charger, 3000W	MX002952
5	PC board adapter, Inverter Charger Controller	MX3511

DC Power Supply

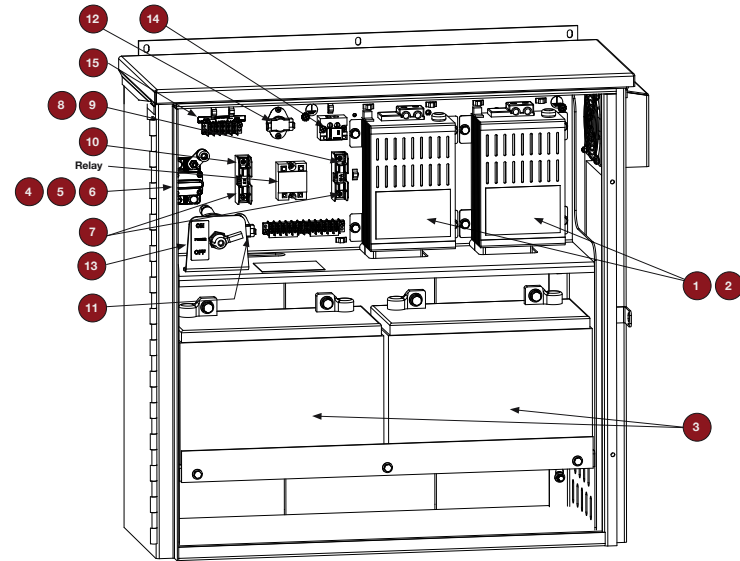

DC Power Supply

Item No.	Part Name	Part Number	UPS Models
1	Battery Charger, Retrofit HyCharger DC, 115VAC	MX2918-02	115VAC, 60/50Hz input
2	Battery Charger, Retrofit HyCharger DC, 208/230VAC	MX2914-02	208VAC/230VAC, 60/50Hz input
3	Battery, 12V, 110Ah, AGM	MX000877	all
4	Circuit Breaker, 120A DC	MX000843	all 30F UPS, 40F UPS, 80 UPS (DX1.7, DX, DX1)
5	Circuit Breaker, 150A DC	MX001096	200 UPS (444DX)
6	Circuit Breaker, 60A DC	MX000842	all 15 UPS, 40 UPS (DS, DE)
7	Fuse Block	MX000863	all
8	Fuse, 250V, 20A	MX002897	208VAC/230VAC, input
9	Fuse, 250V, 25A	MX002941	115VAC, input
10	Fuse, 250V, 5A	MX000864	all
11	Thermostat, Heater, Open 38°F, Close 28°F	MX002894	all
12	Thermostat, Fan, Open 95°F, Close 110°F	MX002916	all
13	Switch, Disconnect, DC Power Supply	MX000844	all
14	Terminal Block, 2-Pole	MX000859	all
15	Terminal Block, 5-Pole	MX001270	all

Nice, a world without limits.

Industry leading manufacturer of gate automation solutions

Niceforyou.com

**Nice North America
Corporate Office**

5919 Sea Otter Place, Suite 100
Carlsbad, Ca 92010
Tech: (760) 438 7000
Sales: (760) 438 7000
Toll Free: (800) 421 1587

**Nice North America | HySecurity
Gate & Barrier Division**

6705 S 209th St, Ste 101
Kent, WA 98032
Tech: (253) 201 2918
Sales: (253) 867 3700
Toll Free: (800) 321 9947

