

HydraSwing™

Installation Instructions

MX3635-01 Rev. G

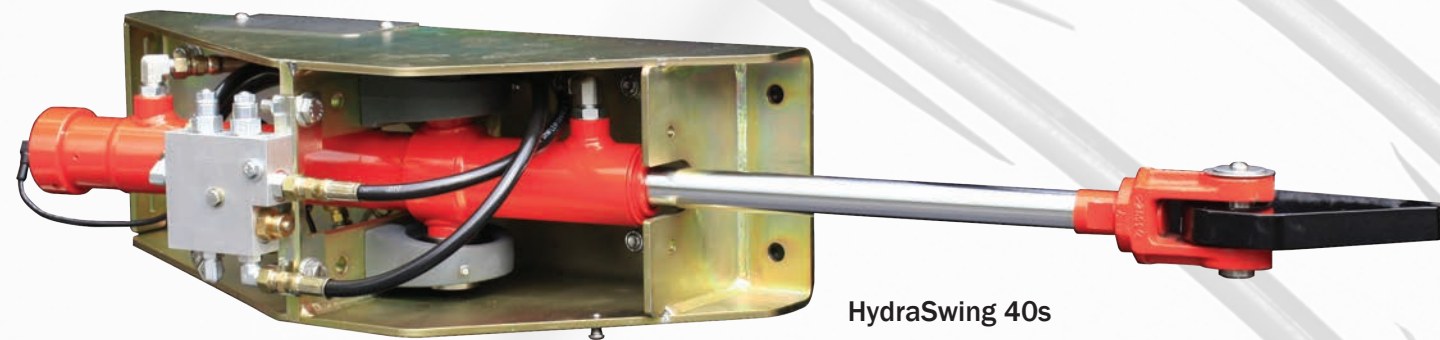

HydraSwing 40s

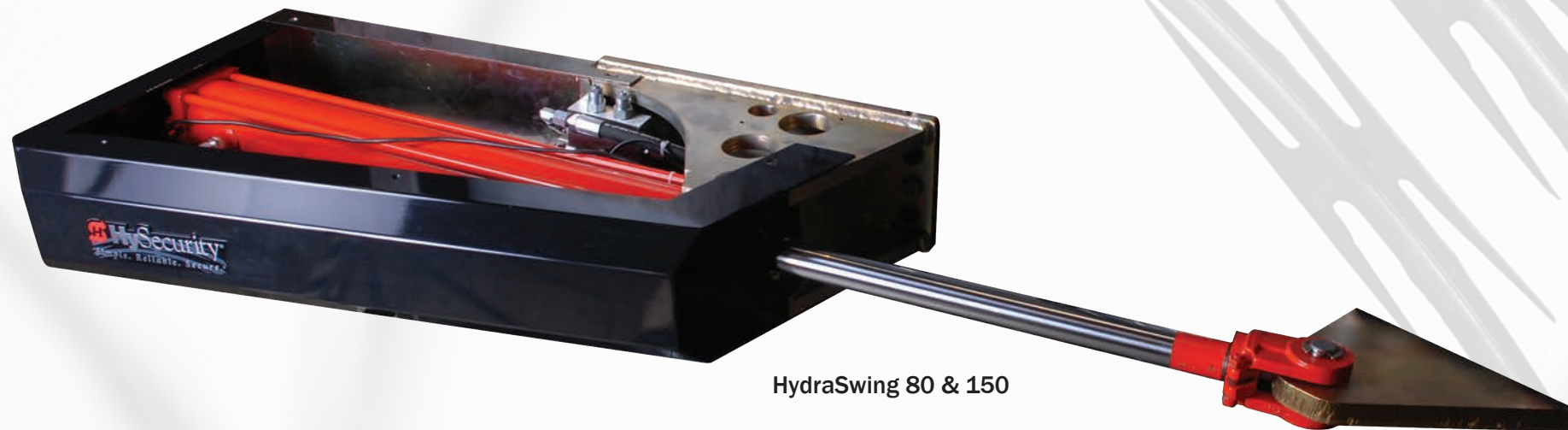

HydraSwing 80 & 150

Models

HydraSwing 40F	4,000 lb (1,814 kg)	10-15 seconds
HydraSwing 40	4,000 lb (1,814 kg)	15-20 seconds
HydraSwing 40 Twin	4,000 lb (1,814 kg)/leaf	15-20 seconds
HydraSwing 40F Twin	4,000 lb (1,814 kg)/leaf	10-15 seconds
HydraSwing 80F	8,000 lb (3,629 kg)	15-25 seconds
HydraSwing 150	15,000 lb (6,804 kg)	20-30 seconds



 **HySecurity**®

a Nice company

800-321-9947 www.hysecurity.com

Linear actuators for large, heavy swing gates and swing gates subject to extreme peak winds

HydraSwing: Plan Site Design

NOTE: Design shown for illustrative purposes only. Drawings are **NOT TO SCALE**.

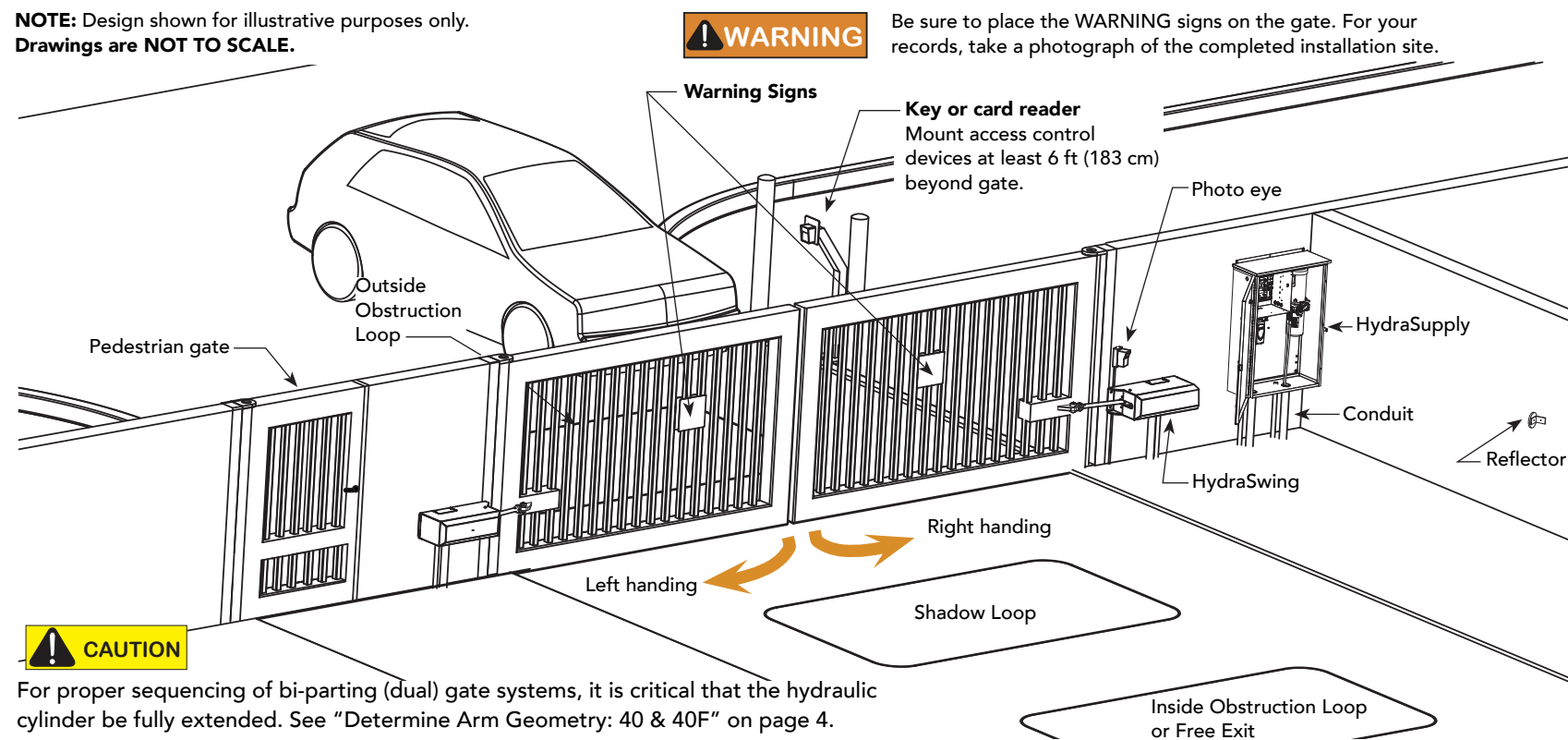

WARNING Be sure to place the WARNING signs on the gate. For your records, take a photograph of the completed installation site.

CAUTION For proper sequencing of bi-parting (dual) gate systems, it is critical that the hydraulic cylinder be fully extended. See "Determine Arm Geometry: 40 & 40F" on page 4.

1 Read & Plan

Read and follow the *Important Safety Information* provided in the *Programming and Operations Manual* prior to installing the HydraSwing. Read and follow these installation instructions and make sure to conform to site specifications and all local and federal regulations and codes.

2 Measure and Calculate

Pay attention to gate swing (retracted or extended cylinder) and clearance around the mounting location. Consider right handing and left handing. Allow for access to brake valves. Use the charts, provided on pages 3 and 4, to determine gate geometry and placement of the chassis and gate mount.

NOTE: For twin units (but not single), it is critical to measure and plan gate installation such that cylinder is *fully extended* when gate is closed (see mounting dimensions).

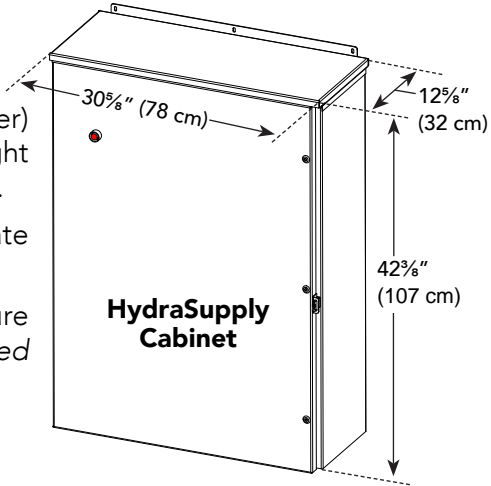

3 Design Vehicle Loops

If automatic close is desired for a uni- or bi-directional gate, a SHADOW and one other loop (IOLD or OOLD) is required. Three loops are preferred: SHADOW, IOLD, OOLD (Free Exit, optional)

NOTE: Loop layout is dependent on uni- or bi-directional traffic and length of gate and width of roadway. Vehicle must move from one loop to the next without loss of detection. The site design shown on this page is for illustrative purposes only.

4 Install conduit for communication and power

Locate and install the HydraSupply within 50 feet (6.1 m) of the HydraSwing gate operator.

NOTE: Order hose through HySecurity. See CAUTION.

CAUTION Remember to order hose through HySecurity! In addition to conduit length, make sure to measure hose requirements inside the HydraSwing and HydraSupply. For example, HydraSwing 80F requires about 1 ft of additional hose length inside the operator and another 2 or 3 ft inside the HydraSupply.

Hose length in feet (Total Run)	Hose Diameter: Model 40 & 40F, Twin	Hose Diameter: Model 80F & Model 150
0 to 50 ft	1/4 inch	3/8 inch
50 to 100 ft	3/8 inch	1/2 inch*

Minimum conduit required	No.	Min. Size	cm
3/8 inch Hydraulic hoses*	1	2 inch	5
1/2 inch Hydraulic hoses*	1	3 inch	7.6
Sensor wire to operator	1	3/4 inch	2
AC Main power	1	1 inch	2.5

Add'l conduit may be ordered and used for:	No.	Min. Size	cm
Bi-parting gate connection for low voltage wiring	1	1 inch	2.5
Heater or Emergency Release options	2	3/4 inch	2

***NOTE:** HydraSwing orders include two (2) fluid-charged hoses and attached fittings totaling up to 50 ft (15 m). Additional hose is billed by the foot. For HydraSwing 80F and 150, use 1/2-inch hose and fittings where the HydraSupply cabinet is installed more than 50 ft from the actuator AND temperatures routinely fall below 0°F. For distances between the HydraSupply and actuator longer than 100 ft (30 m), contact Tech Support.

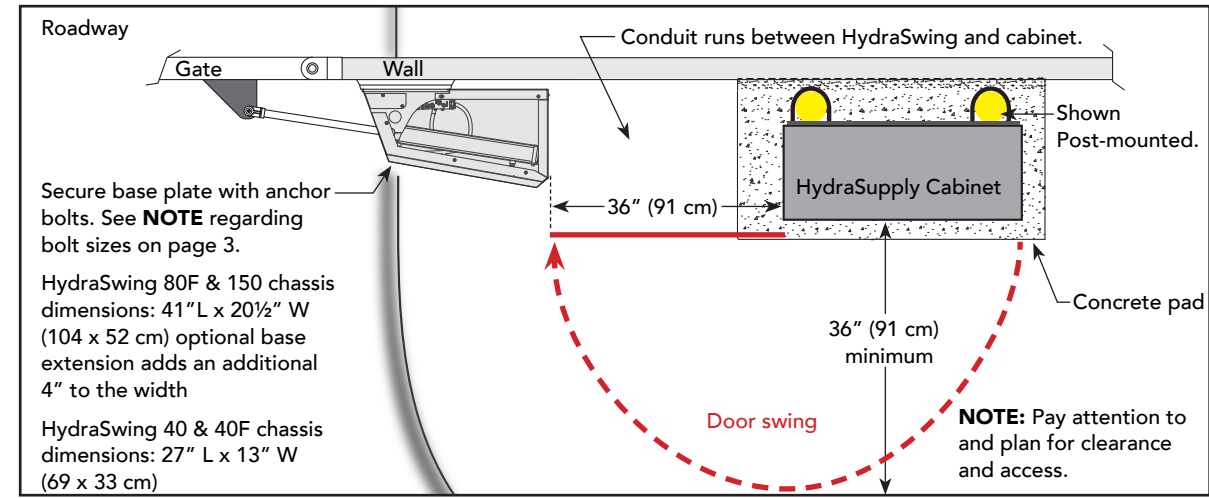
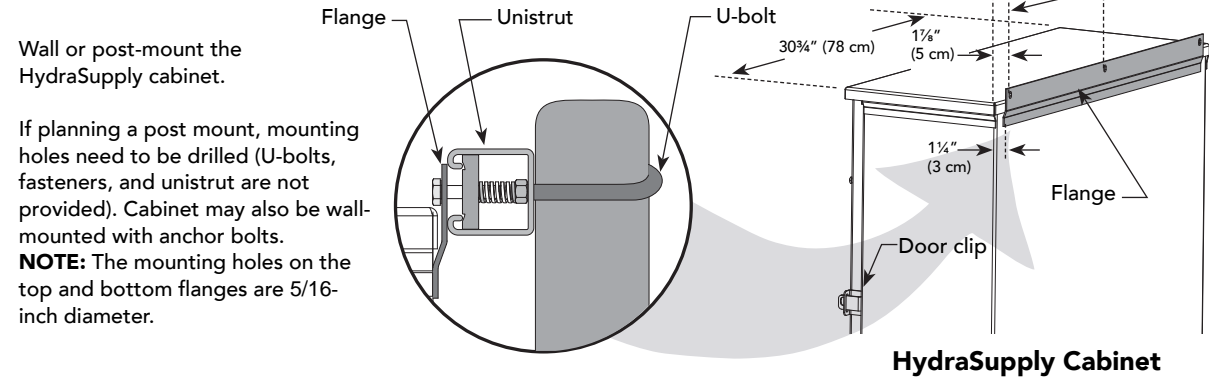
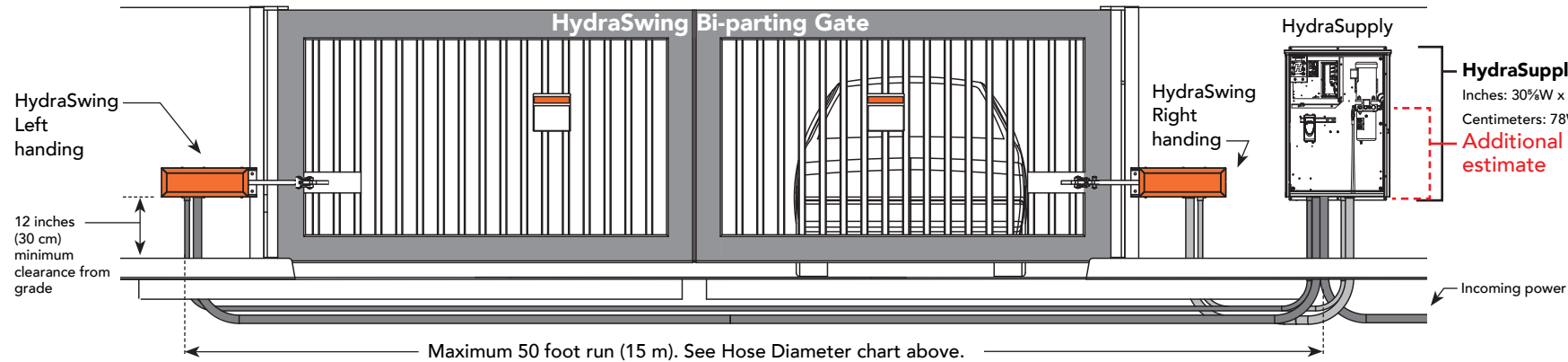

Assembly: Exploded Views

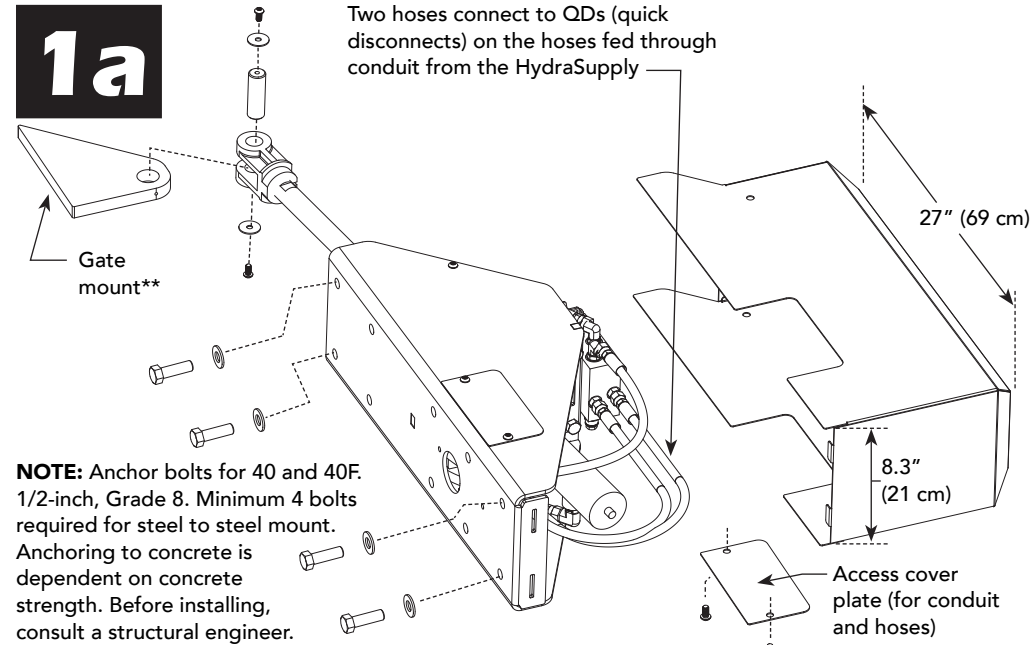

NOTE: Anchor bolts for 40 and 40F. 1/2-inch, Grade 8. Minimum 4 bolts required for steel to steel mount. Anchoring to concrete is dependent on concrete strength. Before installing, consult a structural engineer.

HydraSwing: Model 40 and 40F

HydraSwing 40 & 40F chassis dimensions:
27" L x 13" W (69 x 33 cm)

****NOTE:** Depending on whether the chassis is mounted recessed or elevated, you will need to modify the gate mount to accommodate the gate geometry.

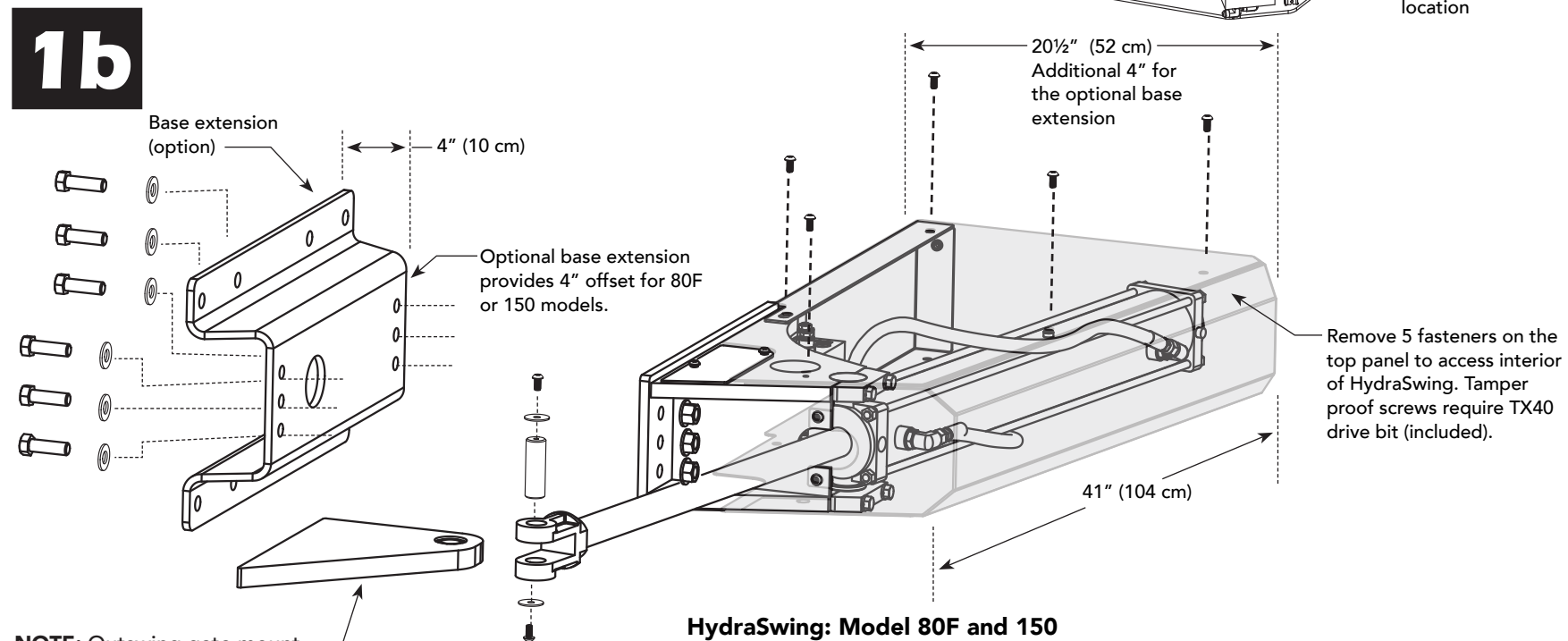

NOTE: Outswing gate mount requires customer fabrication. See pages 4 and 5.

HydraSwing: Model 80F and 150

HydraSwing 80F & 150 chassis dimensions:
41" L x 20 1/2" W (104 x 52 cm) optional base extension adds an additional 4 inches to the width

1. Assemble and secure chassis to mounting surface.*
2. The actuator must be installed so that both cylinders are fully extended at the close limit. The position and measurement can be checked by hand pumping the gate closed until the cylinder stops. When fully extended, the shiny chrome part of the actuator cylinder should be extended 14" on both gates. See the dimensions for reference.
3. Feed hoses through conduit and connect them to the QD fittings (quick disconnects).
4. Ground the gate operator.
5. Feed sensor wire through conduit to HydraSupply and connect it to the 4-pin receiver board.

***NOTE:** Refer to Arm Geometry, on pages 3 and 4, for mounting dimensions and requirements. It is recommended the actuator be tack welded or bolted initially in order to allow easier remounting if required during installation.

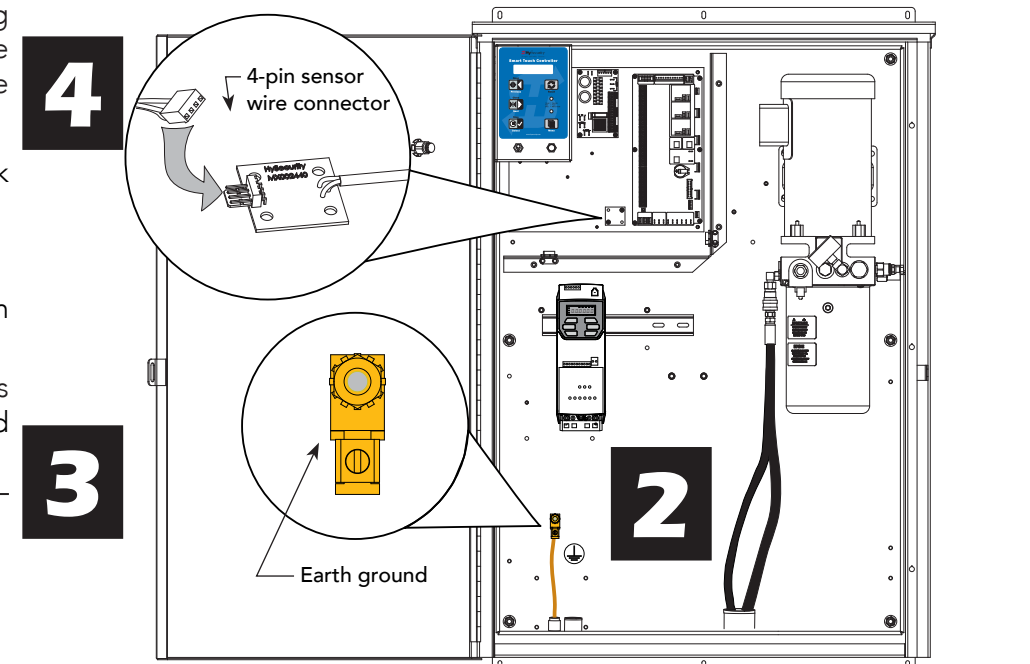
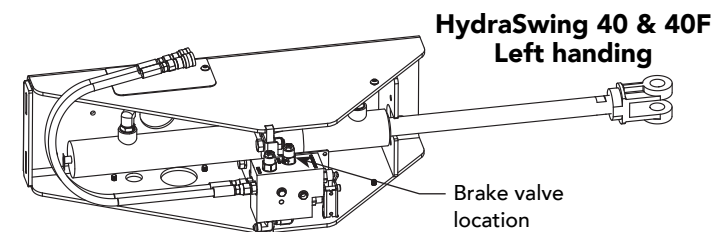
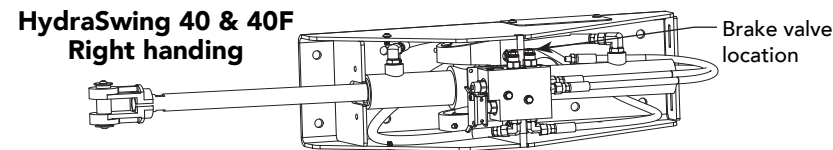

3

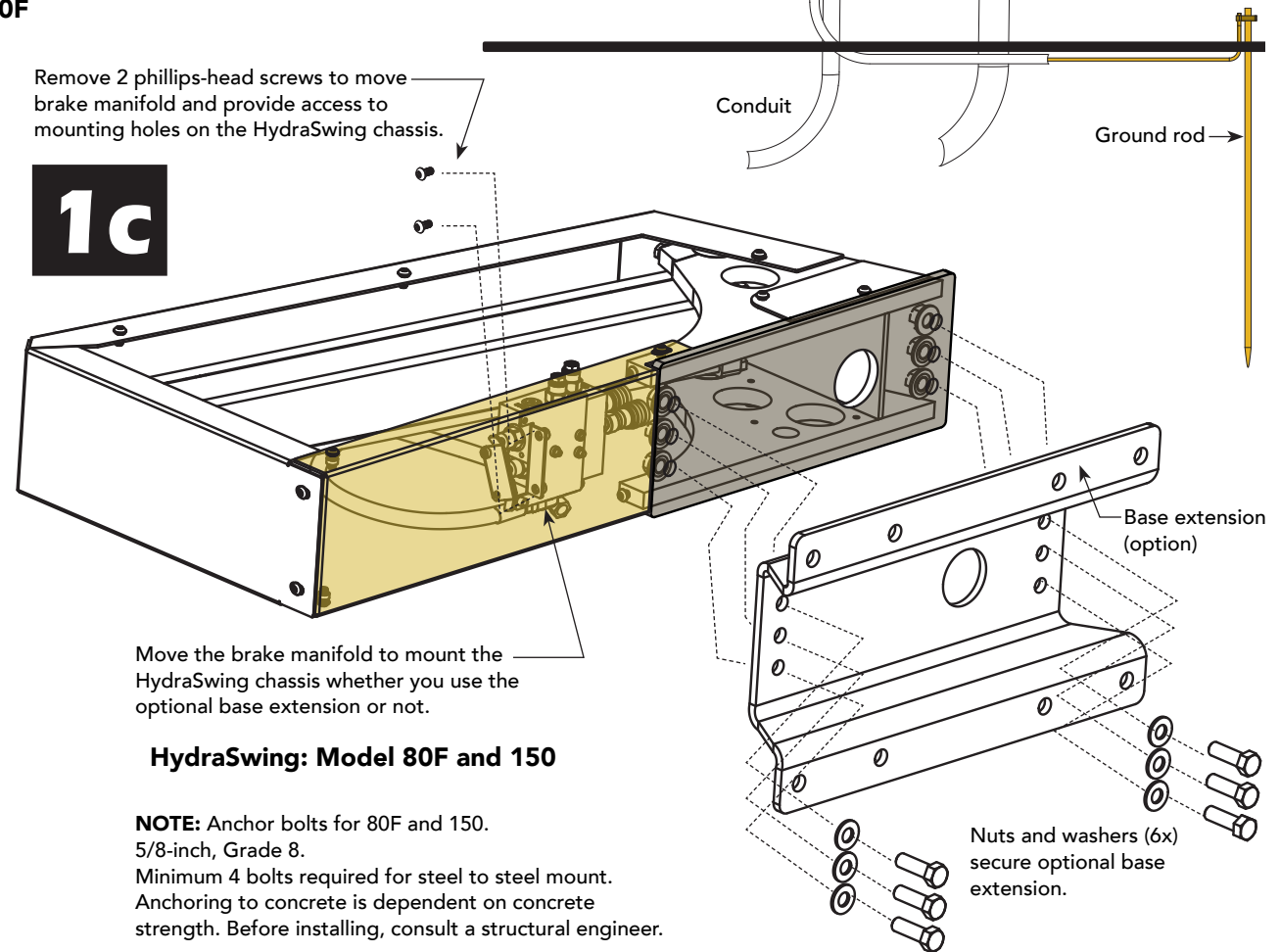

HydraSwing: Model 80F and 150

NOTE: Anchor bolts for 80F and 150. 5/8-inch, Grade 8. Minimum 4 bolts required for steel to steel mount. Anchoring to concrete is dependent on concrete strength. Before installing, consult a structural engineer.

Drawings NOT to Scale

Determine Arm Geometry: 40 & 40F

1 Close the gate. Measurements are based on a closed gate. Use the hand pump, if necessary. For bi-parting (dual) gates and proper sequencing on HydraSwing 40 Twin or 40F Twin models, the hydraulic cylinder must be fully extended. Abiding by arm geometry on this page is critical. The cylinder must be fully extended when on the close limit. Especially important on twin units.

2 Three cylinder positions adjust for the differences in surface mounting requirements: *shimmed, flush, or inset* (notched). For example, inset type mounts use Cylinder Position 3.

Inswing Closed Position: Center hinge

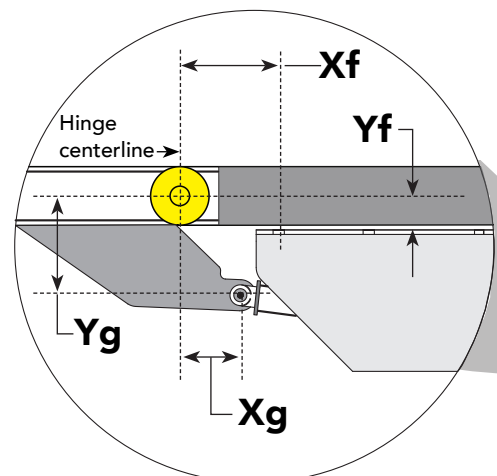
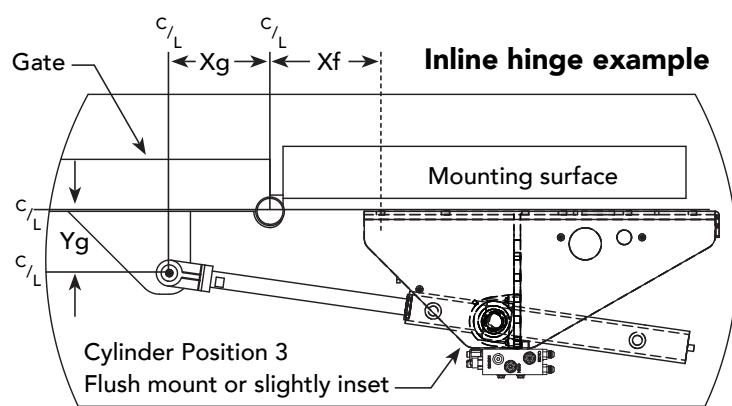
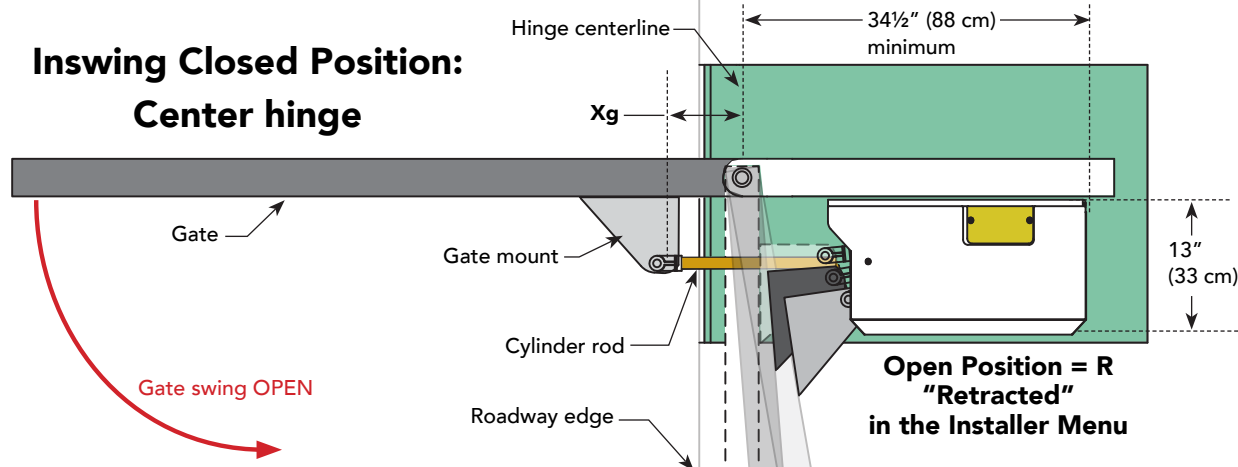

CAUTION **Outswing Gate**
See NOTE's.

NOTE: Outswing gate mount requires customer fabrication.

Gate Opening and Gate Geometry: Inswing

Degree of Swing	Xf	Xg	Yg
90	8" (20 cm)	8 1/4" (21 cm)	5 1/4" (13.3 cm)
95	8 1/4" (21 cm)	8" (20 cm)	5" (12.7 cm)
100	8 5/8" (22 cm)	7 3/4" (19.7 cm)	4 3/4" (12 cm)

Mounting Surface: Shimmed, Flush, or Inset

If Yf dimension is between	Then use Cylinder Position
2 3/4" to 3 3/4" (7 to 9.5 cm)	1
1 to 2" (2.5 to 5 cm)	2
0 ± 1/2" (0 ± 1.3 cm)	3

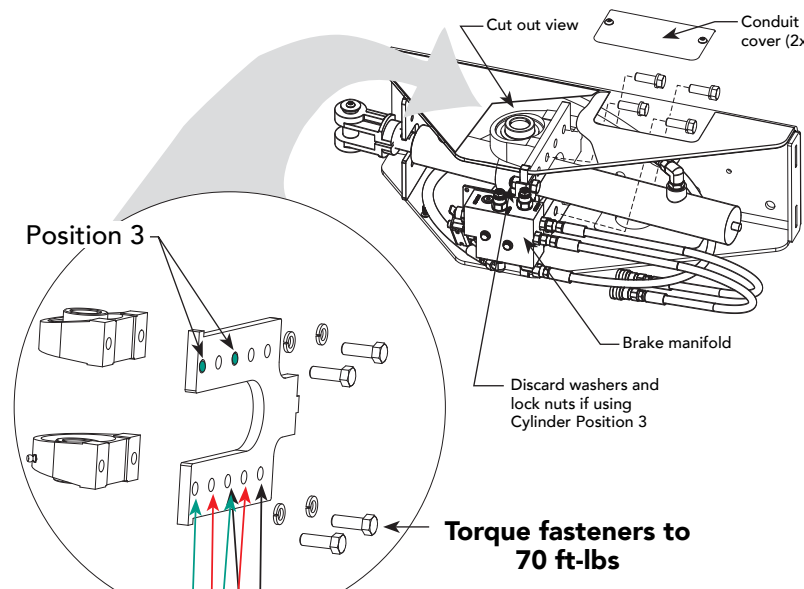

Outswing Open Position: Center hinge

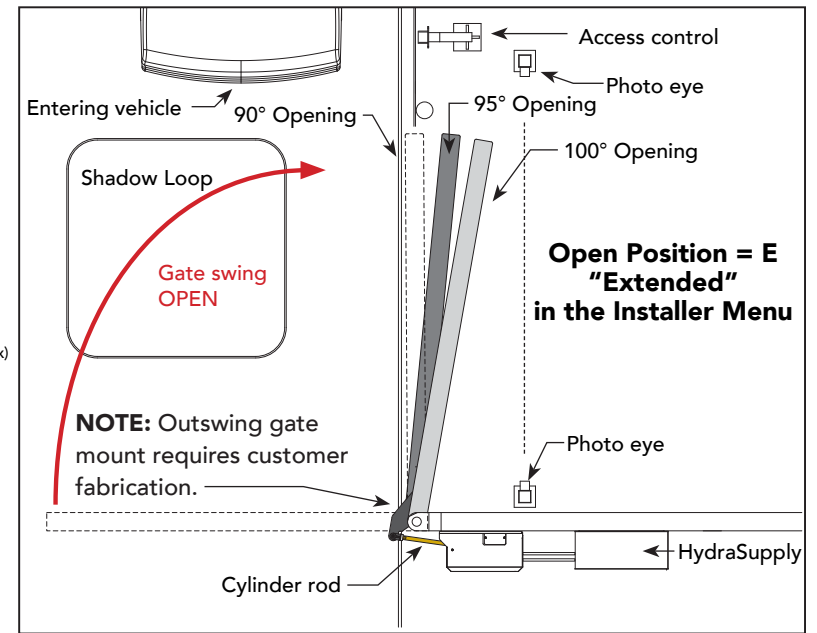

Gate Opening and Gate Geometry: Outswing

Degree of Swing	Xf	Xg	Yg
90	8" (20 cm)	5 1/4" (13.3 cm)	8 1/2" (21.6 cm)
95	8 1/4" (21 cm)	5 5/8" (14.3 cm)	7 1/2" (19 cm)
100	8 5/8" (22 cm)	6" (15.2 cm)	6 3/4" (17.1 cm)

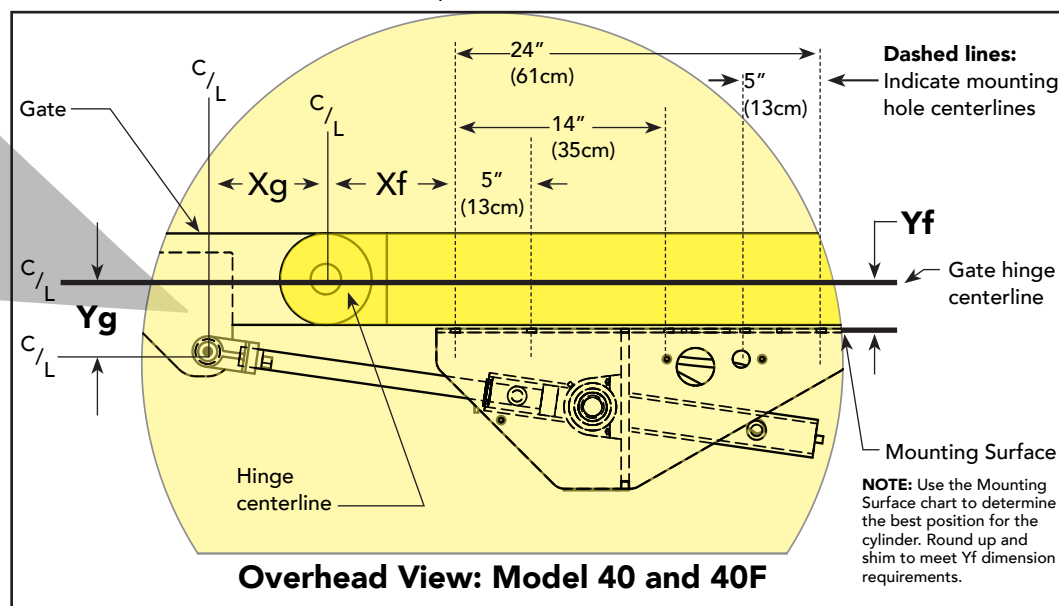

Overhead View: Model 40 and 40F
Inswing mount shown: Center hinge

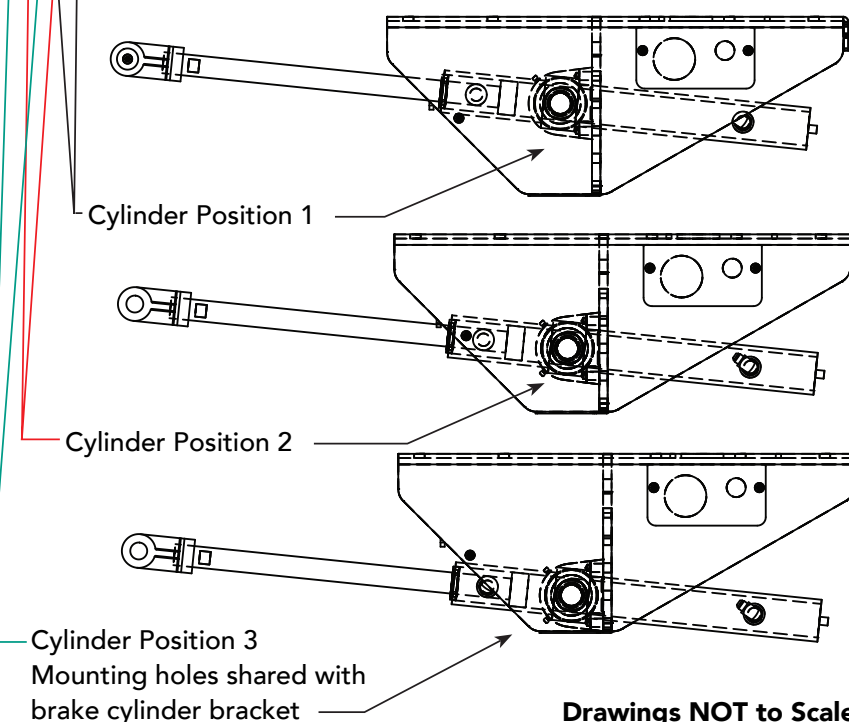

Drawings NOT to Scale

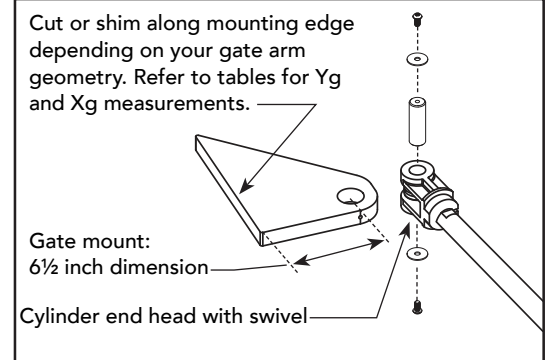

CAUTION

Use the measurements for your gate type: **Inswing or Outswing.**

Measure and cut (or shim) gate mount to meet the Yg requirement. Fasten the gate mount to the cylinder to meet the Xg requirement. Tack weld until hoses available or the accuracy of the dimensions are confirmed. The gate mount and cylinder need to remain in a horizontal plane throughout gate travel. If any vertical movement occurs, the load on the cylinder is strained and will lessen its life and void the Warranty.

Determine Arm Geometry: 80F & 150

Drawings NOT to Scale

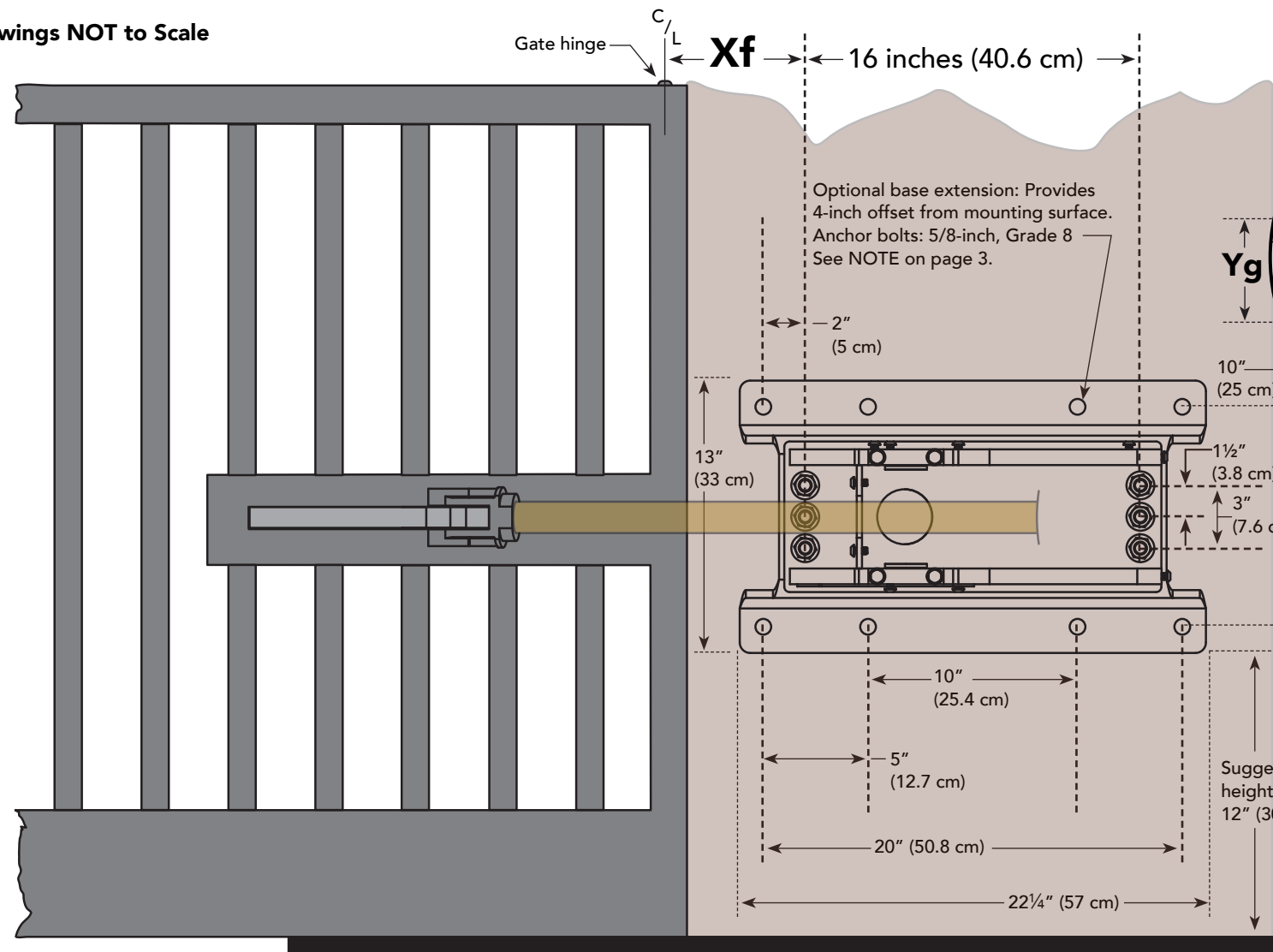

Outswing gate mount requires customer fabrication

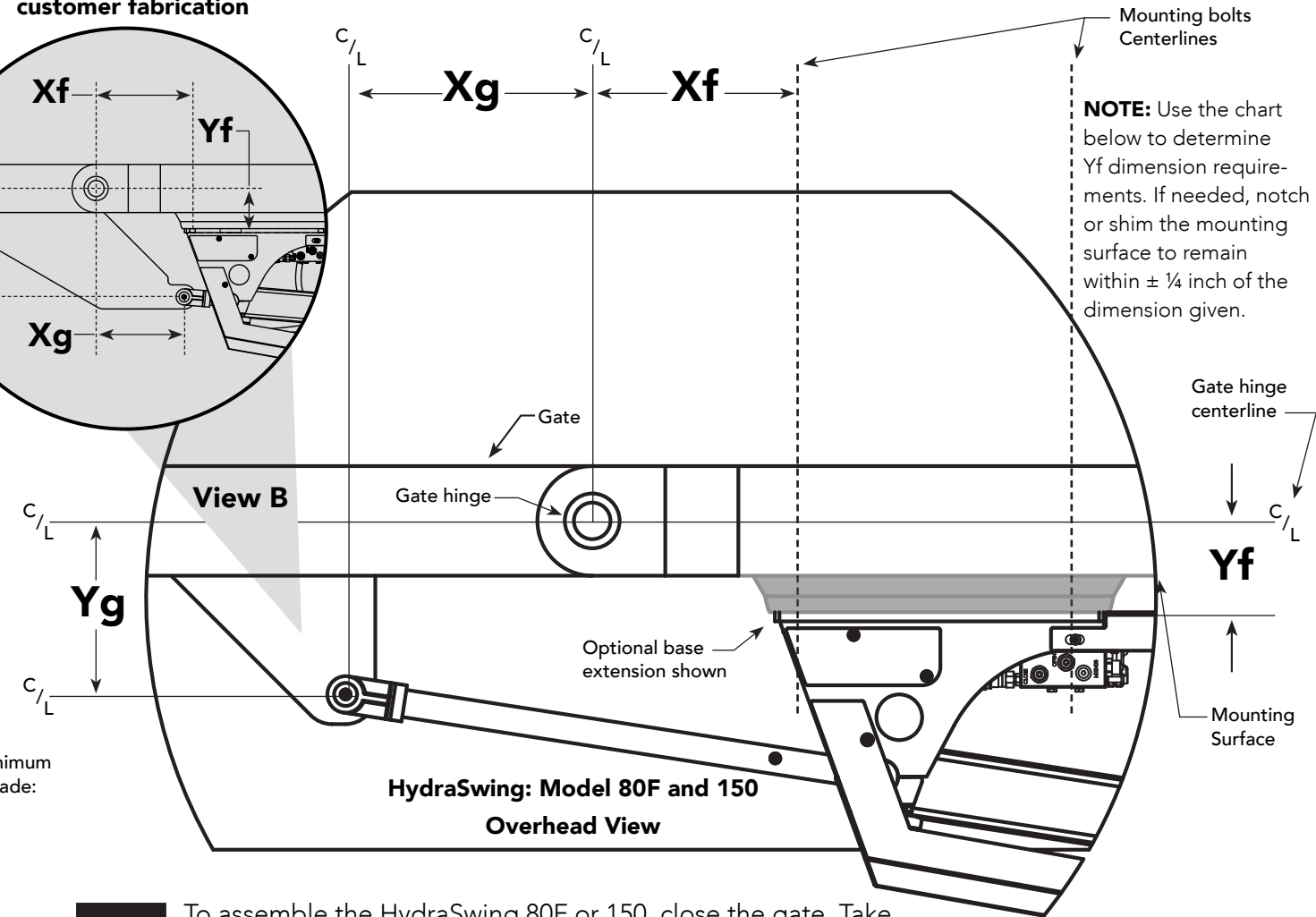
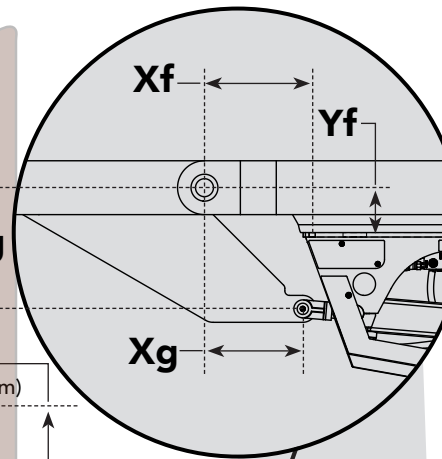

NOTE: Use the chart below to determine Yf dimension requirements. If needed, notch or shim the mounting surface to remain within $\pm 1/4$ inch of the dimension given.

HydraSwing: Model 80F and 150
Mounting Dimension 90° Opening with Optional Base Extension: Provides 4-inch offset

Mounting tab included: 1" (2.5 cm) thick. Must be cut and welded by installer to meet Yg measurement requirements.

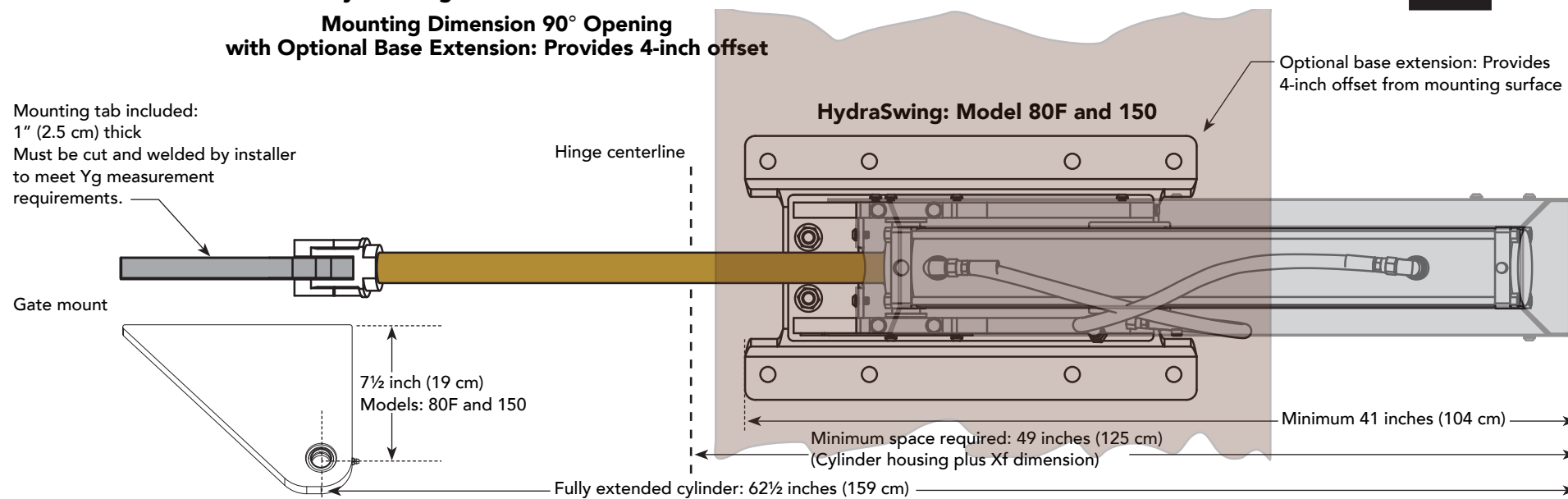

1 To assemble the HydraSwing 80F or 150, close the gate. Take measurements based on a closed gate position.

2 Determine the best geometry for your site. An optional 4-inch base extension may be ordered to help create the appropriate Yf mounting surface dimension.

CAUTION The gate mount and cylinder need to remain in a horizontal plane throughout gate travel. If any vertical movement occurs, the load on the cylinder is strained and will lessen its life and void the Warranty.

Gate Opening and Gate Geometry: 80F & 150				
Degree of Swing	Xf	Xg	Yf $\pm 1/4$ "	Yg
90	11" (28 cm)	13 1/2" (34.3 cm)	5" (12.7 cm)	9 1/2" (24.1 cm)
100	11 1/4" (28.6 cm)	13 3/4" (33.6 cm)	3 1/2" (8.9 cm)	8" (20.3 cm)

Gate Geometry: View B Outswing: 80F & 150				
Degree of Swing	Xf	Xg	Yf $\pm 1/4$ "	Yg
90	12" (30.5 cm)	11" (28 cm)	5" (12.7 cm)	13 1/2" (34.3 cm)

Wiring AC Power



Turn OFF AC power at the source (circuit breaker panel) before accessing the wires in the HydraSwing. Follow facility Lock Out/Tag Out procedures. Make sure all power switches are in the OFF position. Follow all electrical code standards and regulations.

Power connection

Size the primary wires, appropriately. Consider the voltage, horsepower, and length of the wire run from the main power panel.

Verify you have the proper input voltage and make sure the motor and transformer are wired correctly.

NOTE: Use a 20A (minimum) protected with a 20A Inverse Time Breaker for all AC motor connections.

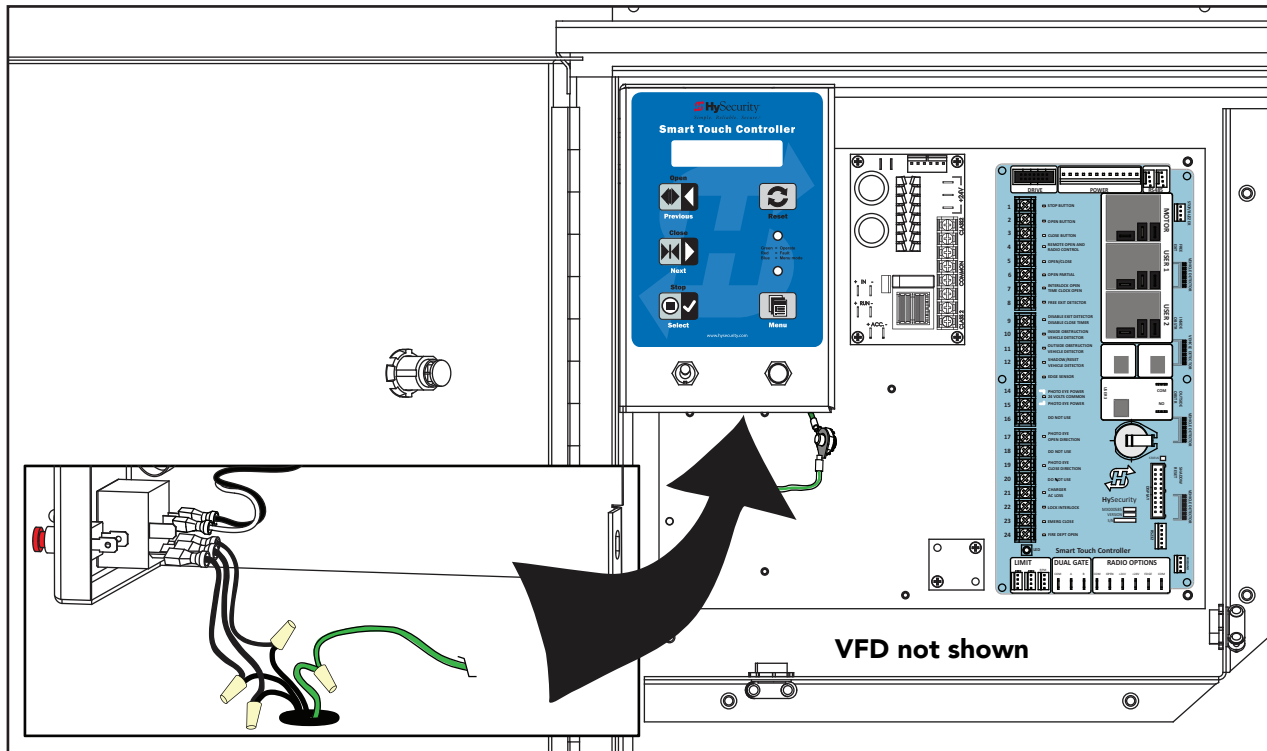

- 1. Connect to Power:** Three pig tails and a ground are available for connection to a 3 Phase power source (3Ø) on the back of the keypad display enclosure.

- 2. Connect AC Power:** Wire nut the incoming power wires to their appropriate pig tails. Attach the ground wire to the chassis. A wiring diagram is provided in the appendix. Note that for 1Ø wiring, only the two outside connections/pig tails are used.



Wiring of gate operators must conform to NFPA and NEC standards and comply with all local codes. When the installation is compliant and complete, turn on AC power at the source and at the control box. For Variable Frequency (VF) operators, make sure the connection wires match the voltage found on the operator's nameplate.



In-Field Connections: HydraSwing operators are field re-configurable for 1Ø or 3Ø, 208/230VAC input power without changing the VFD. However, if reconfiguring from 208/230VAC to 460/480VAC the VFD Motor Controller in a 208/230VAC unit must be replaced with a VFD Motor Controller manufactured for the higher (460/480VAC) voltage input. Any electrical damage occurring to the operator will not be covered by the Warranty.



HydraSwing operators CANNOT be connected to 115/120VAC, 1Ø power or 575V, 3Ø power. If any attempts are made to do so, serious injury and possible electrical shock may result. Any electrical damage occurring to the operator will not be covered by the Warranty.

Turning the Power Switch ON

The AC power disconnect switch (ON/OFF switch) is located on the same enclosure as the STC keypad and display.

When power is turned ON, a green status light on the Smart Touch Controller blinks. The status light appears below the disc battery and indicates that the processor is receiving power.

Green LED flashes indicating processor is receiving power.

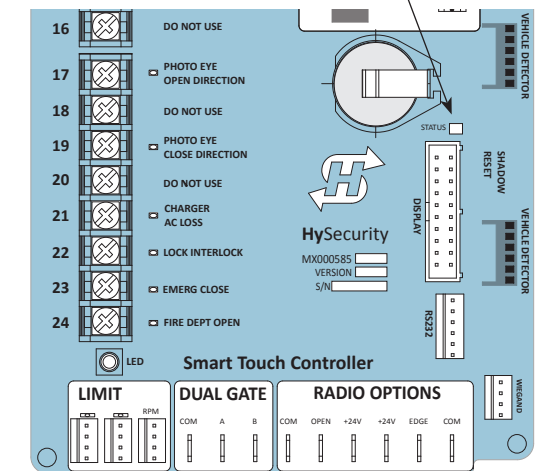

Site Considerations

HySecurity gate operators are intended for permanent installation. Make sure you prepare the site with the following considerations:

- Make sure all electrical wiring is properly routed via conduits.
- Check the distance of the wire run from the main panel to the gate operator. Make sure the wire size of the branch circuit supplying power to the gate operator is large enough to avoid excess voltage drop. Refer to *Wire Sizing and Runs* in the *HydraSwing Programming and Operations Manual*.
- Make sure the available power source matches the electrical requirements specified on the voltage nameplate.



Each gate operator is built to run on a specific line power voltage and phase. Failure to ensure the source voltage, phase and frequency match, what is specified for the equipment, may result in severe damage to the equipment.

- Make sure a 20A circuit (minimum) protected with a 20A Inverse Time Breaker is provided.
- Verify that the operator is electrically grounded per NFPA 780 and NEC Article 250, and local codes.

NOTE: Refer to the *HydraSwing Programming and Operations* manual for Important Safety Instructions, programming, troubleshooting, maintenance and general information

Complete the Installation

Replace Vent Plug with Breather Cap



Failure to perform the following procedure will cause premature pump shaft failure and void the Warranty.

The gate operator has a vent plug that keeps the hydraulic fluid from spilling during shipment. The vent plug must be replaced by the breather cap before operating the swing gate.

- Remove the vent plug and discard it.
- Replace the vent plug with the breather cap.

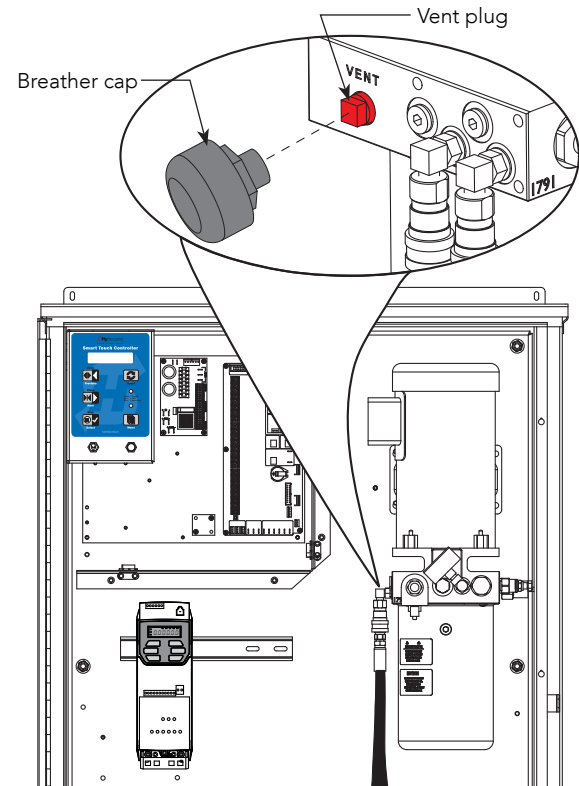

Manual Release



Before attempting a manual release, make sure the gate is not in motion and power is disconnected (turned OFF).

The Manual Release is used to manually OPEN the gate for emergency access. To manually OPEN and CLOSE the gate during installation or power failure, use the Manual Hand Pump. When the hoses are installed, the gate may be opened (cylinder retracted) manually by moving the release lever as shown in the illustration.

NOTE: For models 80F and 150, DO NOT extend the cylinder using the manual release lever. Refer to CAUTION below. Outswing installation sites must pull the cylinder pin (disengages the gate from the operator) or use the hand pump.



Pushing the gate closed when the lever is in the released position may cause an air pocket to form in the hydraulic cylinder and cause overflow from the reservoir. If you notice fluid leakage, stop gate travel immediately and use the hand pump.

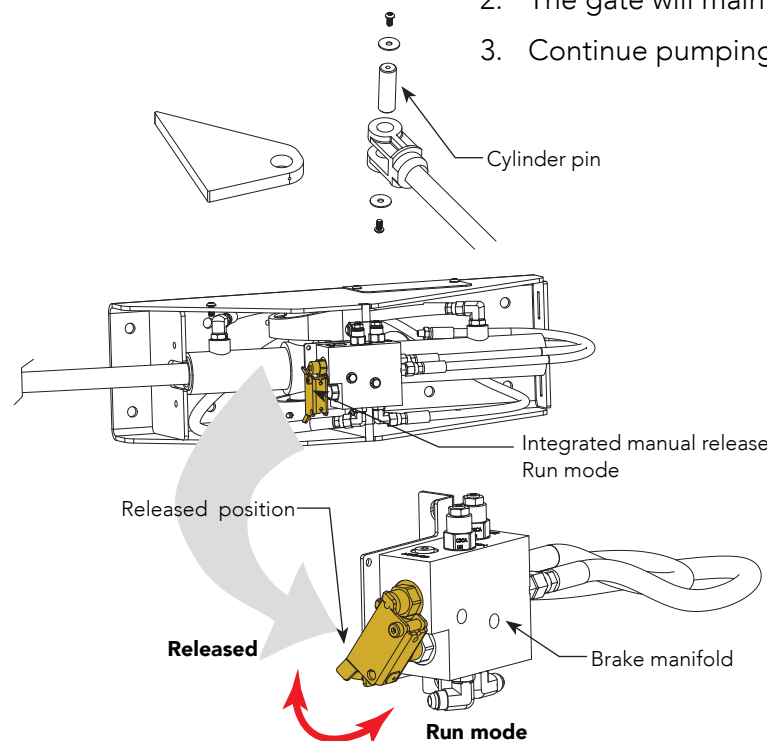

Manual Hand Pump: 40, 40F, 80F and 150 Models

When the hoses are installed, a hand pump can be used to manually operate the hydraulic mechanism that secures the gate. In the event of a power failure, manual operation is achieved by accessing the hydraulics cabinet. Follow the steps below to open or close the gate:

NOTE: An integrated manual release mechanism exists on the brake manifold assembly.

Open the Gate using the Hand Pump

1. Open the HydraSupply cabinet.
2. Turn the power switch OFF.
3. Locate the hand pump and the Knurled Knob on the Open Valve.
4. Firmly, pull and twist the knurled knob counterclockwise. Release the knob so that it remains in the open position.

NOTE: If the valve re-seats itself, repeat the pull and twist in the opposite direction until the valve remains open.

5. Begin pumping the handle up and down. As hydraulic fluid is pumped into the cylinder, it begins to move the gate.
6. Continue pumping until the gate reaches full open position.
7. Turn the knurled knob so it springs back to the closed position.

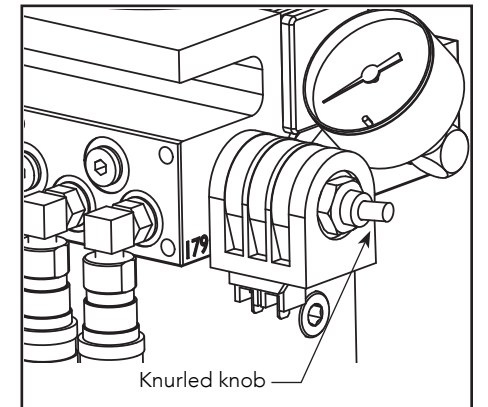

Close the Gate using the Hand Pump

1. Check that the knurled knob is in the closed position. Begin pumping the handle up and down. The gate slowly closes with the pumping motion.
2. The gate will maintain its position whenever you stop pumping.
3. Continue pumping until the gate reaches the full closed position.

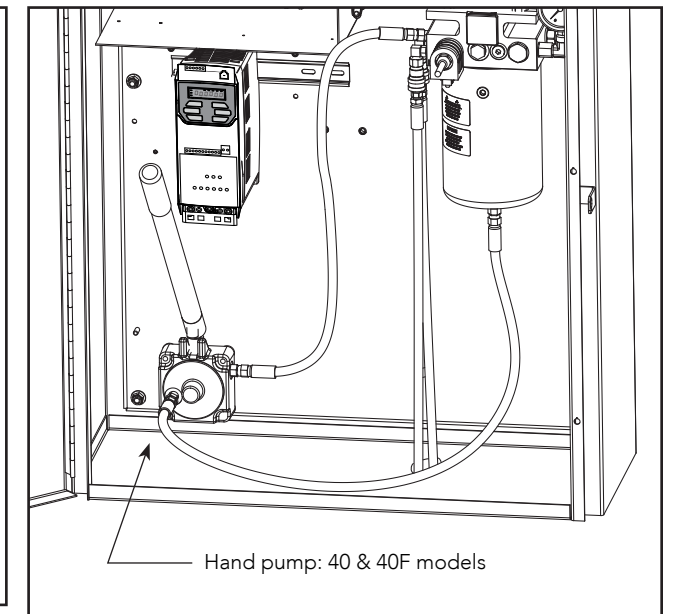
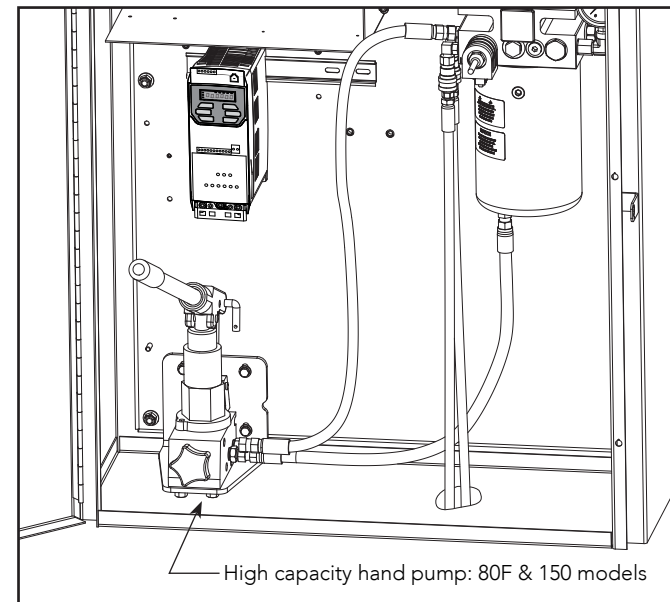

Drawings NOT to Scale

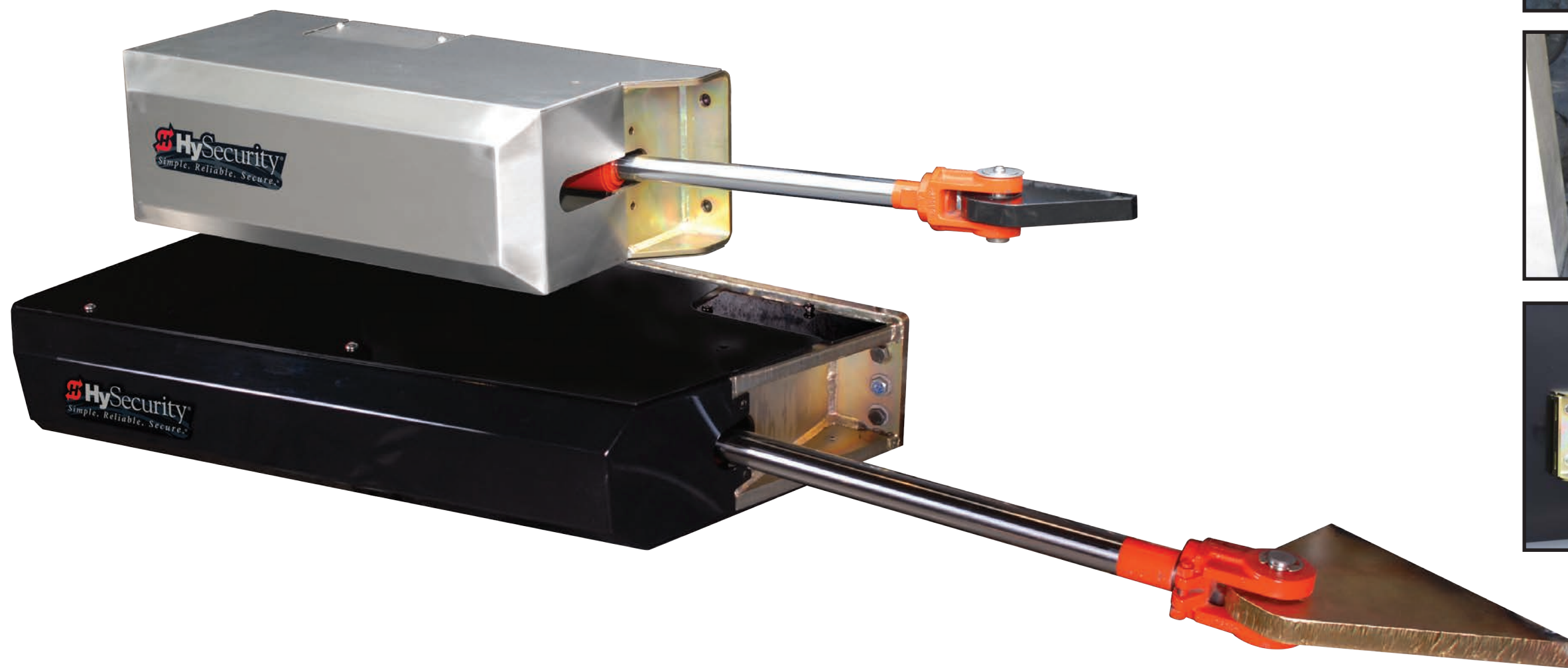

 **HySecurity**
a Nice company

Contact Information: Visit <https://support.hysecurity.com/hc/en-us> for installation manuals, replacement part instructions, part diagrams and more. Qualified Nice | HySecurity distributors are experienced and trained to assist in resolving installation problems. For the name of a qualified distributor near you, call Nice | HySecurity at 800-321-9947. *Before contacting your distributor or Nice | HySecurity Technical Support, obtain the serial number of your operator.