

HydraWedge™ SM50

Premium security
and reliability

Two day install Crash-Rated
Anti-Ram Barrier



Reliable. High Cycle. Security Event Reporting

HydraWedge™ SM50 is a next generation, highly engineered, hydraulic vehicle barrier wedge that meets or exceeds every hardened Access Control Point security requirement.



Count on highest quality and reliability

Reliability is HySecurity's culture, reputation and brand. HySecurity relies on refined and consistent attention to detail and commitment to high quality.



Superior wedge specifications

- Small footprint and shallow foundation allows match of roadway surface.
- Access hydraulics easily via top access panels.
- Spring counterbalance increases speed and reduces motor HP requirement and maintenance.
- Available in 2 to 4 meter widths.



High cycle - fast throughput

Manage traffic AND maintain high security. Employ it for traffic control AND final denial, or cycle barrier arm alone during peak traffic - and maintain EFO for security.



5-year warranty

on hydraulics and electronics. Industry-exceeding warranty is your HySecurity assurance.

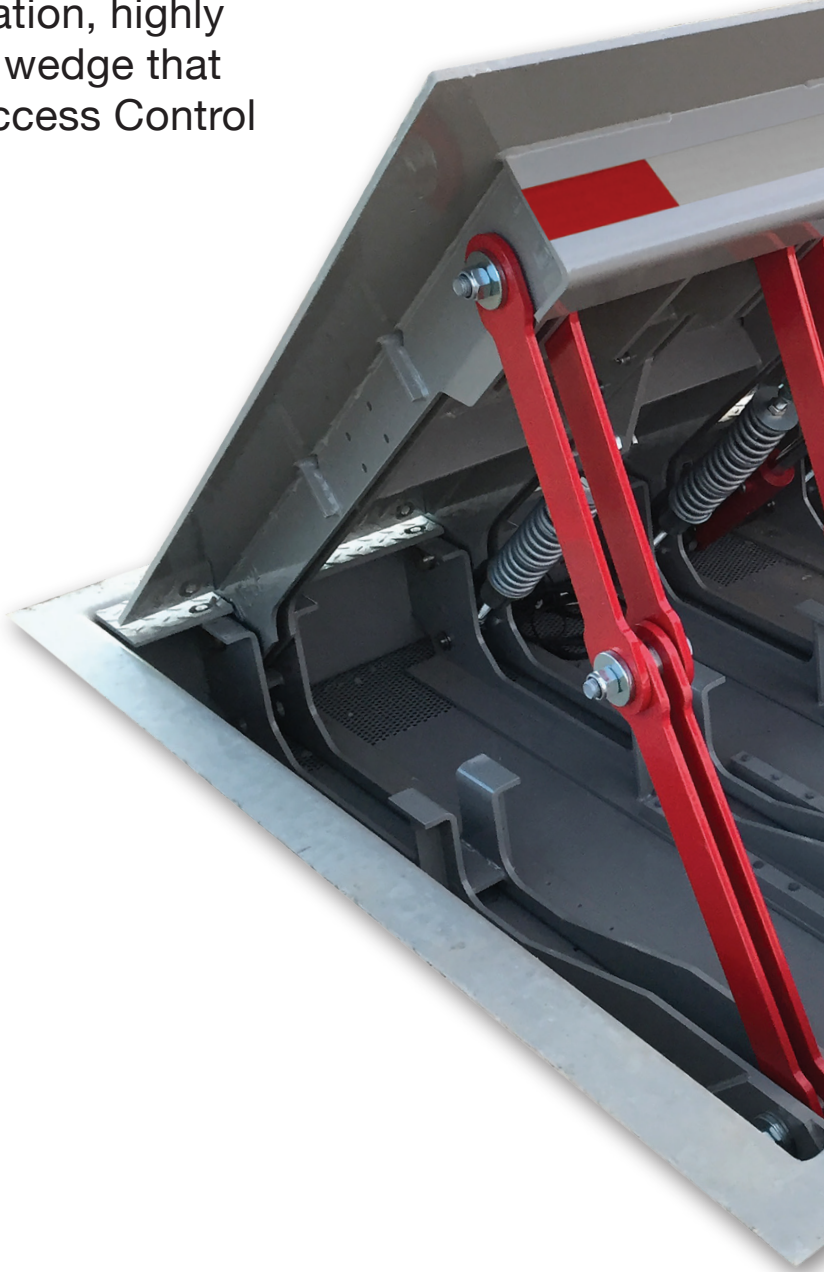



Fast, two day installation

12 inch shallow mount, small footprint concrete foundation and minimal rebar reduces installation time and minimizes conflict with underground utilities.



Record (or monitor) security events

Security breach, gate system and accessory status, system malfunction and maintenance alerts recorded in non-volatile memory and/or reported in real time via Ethernet.

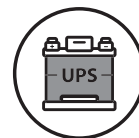

Hundreds of cycles after AC power loss

UPS battery backed-up HydraWedge SM50 UPS
HySecurity's DC Power Supply with HyCharger DC™ supplies hundreds of cycles after AC power loss



HydraSupply XL™ Twin
One HydraSupply, two Controllers

3 Crash Certification. Ultra-Reliable Hydraulics

Domestic and International

ASTM F2656-15 M50-P1 & IWA14-1: 2013 & PAS 68: 2013

Trust HydraWedge SM50 to stop threats in their tracks. It passed the toughest U.S. and International crash tests, ASTM F2656-15 M50-P1, IWA14-1 and PAS 68, with zero penetration. It is crash certified at its smallest and widest blocking width, 2 and 4 meters. HydraWedge SM50 secures any domestic and international high security site from terrorist or other access control point threat.

Two to four meter width. Zero penetration

See the HydraWedge Crash Test Videos at:
<http://bit.ly/HydraWedgeCrash>





Over 100,000 Industrial and Anti-Ram Hydraulic Installations

HySecurity crash and industrial hydraulics benefit from proximity to Seattle and aviation grade hydraulic design and manufacturing resources. We outperform and outlast all competitor products, with minimal maintenance and downtime. Proven history since 1980.

Typical High Reliability Hydraulic Applications

- Aviation - wing control surfaces, rudder, controls
- Heavy equipment - construction, farm, manufacturing
- Hydraulic elevators
- The car you drive - brakes and power steering
- HySecurity industrial and crash gate operators

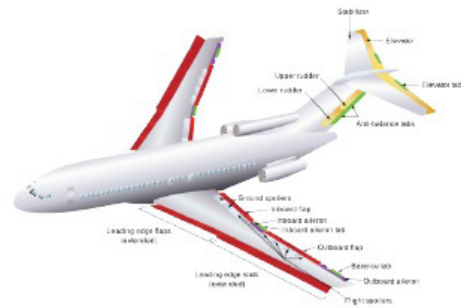

Installers Speak Out

- “When installing active vehicle barrier systems at critical infrastructure sectors, the reliability of a product is critical. HySecurity’s, consistent, robust and reliable hydraulic control system gives PSG the confidence to install them for our highest security customers.”
Troy Blood, Perimeter Security Group, WA
- “They last forever and require almost no maintenance. HySecurity hydraulics give me peace of mind.”
Jim Turner, Gatekeeper Security Integrators, LA
- “Mid-Atlantic Entry Systems has been installing HySecurity hydraulic operators for over 25 years. HySecurity is the only hydraulic operator we install. Our customers expect Mid-Atlantic to provide high quality, reliable operators and HySecurity allows us to do that.” Tim Morgan, Mid Atlantic Entry, VA
- “I have installed and serviced HySecurity hydraulic operators for over twenty years; their simple hydraulic system has always been the most reliable on the market.” Randy Saylor, Foster Fence, TX

Proven HPU Reliability/5 year warranty

- Compact power and control design reduces system footprint
- Light enough to install with loader or forklift. No crane required
- Heavy duty: thousands of cycles per day
- 3 sec Open/Close cycles - 1 sec EFO
- 4 b/u cycles on accumulator after power outage*
4 b/u cycles divided between twin wedges*
- Hand pump for manual operation
- Wide temperature range
-40° to 158°F (-40° to 70°C)
- Integrated manifold w/state of art cartridge valves yields high performance in a compact package

* Hundreds of no-power backup cycles with HydraWedge SM50 UPS

UPS: DC Power Supply w/HyCharger DC™



- Maintain security and full functionality after AC power loss
- Hundreds of DC cycles
- Powerful 50A 3-stage, double redundant charger
- Sealed, maintenance-free AGM batteries
- Long battery life
- Insulated and fan ventilated enclosure

HPU: HydraSupply XL™ (Pictured: Two controllers for twin model)



- Ultra-reliable
- High cycle
- Fast - 3 sec half cycle - 1 sec EFO
- 4 accumulator B/U cycles
- Hand pump for manual operation
- Minimal maintenance

Powerful Integration

In the Palm of Your Hands

Take control of your Access Control Point. Program exacting site-specific operation without the need for expensive, custom PLC design or custom software development. Eliminate your dependence on proprietary systems that are difficult to support.

Program and troubleshoot

- Microprocessor-based (Non-PLC)
- 21 field configurable inputs
- 3 field configurable user relay outputs*
- 4 plug-in HY-5B vehicle detector sockets
- RS-485 and RS-232
- Date & time stamped fault logs, errors and security alerts
- PC interface provided for easy configuration and quick troubleshooting using Smart Touch Analyze and Retrieve Tool (S.T.A.R.T.)

*Hy8Relay option available. Provides eight additional programmable user relay outputs



Smart Touch Controller Keypad

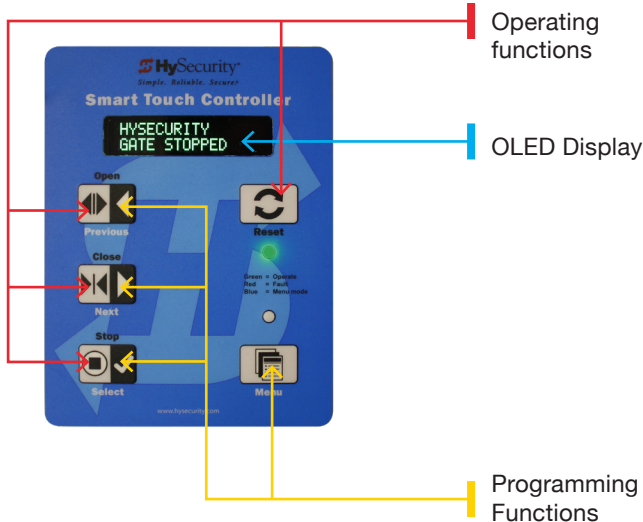

Smart Touch Controller Board

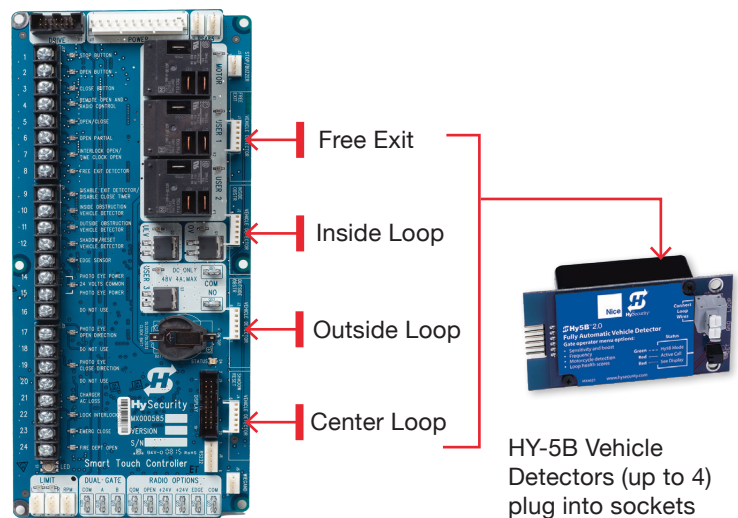

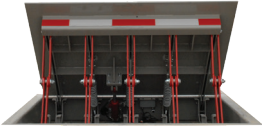

FAST barrier arm and fast wedge for high vehicle throughput

Program operation for wedge and barrier arm or barrier arm only for peak traffic periods

Sequencing two operators: Seamless, out-of-box integration

Easily sequence your barrier arm, slide, or swing gate with HydraWedge SM50. Connect three wires and program the wedge to operate in sequence with a second HySecurity gate. The benefit of one common control platform.

StrongArmPark DC
1.5 - 2.5 sec open
Up to 14 ft (4.2 m) arms



StrongArm
2 to 8 sec open
Up to 36 ft (11 m) arms



- 2 to 4 meter width
- Single or twin.
Standard or UPS.

WITH

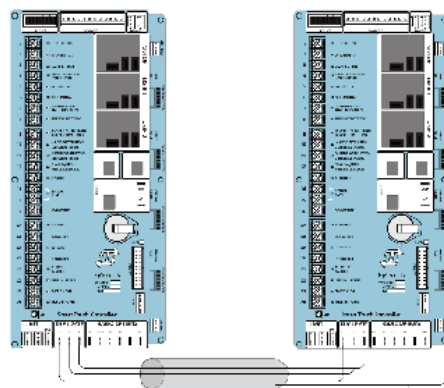

Smart Touch Controller
Easy, quick connection
with common controls

Our Brand—Your Assurance

Over 100,000 Industrial and Anti-Ram High Security Sites Worldwide

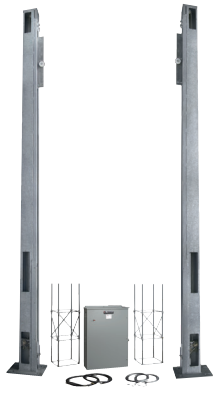

HydraLift



M30

M50



SlideDriver



HydraSwing

Reliability. Reliability. Reliability. That's HySecurity. Especially their hydraulics. You install them and forget them. I've installed hundreds of their hydraulic industrial and crash operators I know!"

Paul Mastin, Phoenix Fence, AZ



Criminal Justice



United Nations



Data Center



Aviation

Verticals

Government, Nuclear Power, Electrical Grid, Water, International Aviation, Data Centers, Petrochemical, Military, Ports, Embassies, Borders, Law Enforcement, Transportation, DOT, Hydropower, VIP Residential

Locations

The Pentagon - DC

United Nations - NY

Baghdad Intl. Airport - Iraq

Reagan International - DC

Dallas Ft. Worth Intl. Airport

LAX Intl. Airport - CA

Sky Harbor Intl. Airport - AZ

FAA - every state

Natl. Institute of Health - DC

Immigration & Naturalization

Shell Oil - TX

Exxon Mobile - TX

Dow Chemical - TX

Postal Service - Most States

Lakawanna Co. Court - PA

Singapore Utilities

Port of Long Beach - CA

Fort Knox, KY

Forensics Lab - Canada

Pepsi Headquarters - NY

Chittenden Locks - WA

Sumail Prison - Oman

SeaTac Airport - WA

Federal Reserve, MN

Fairfax Co. Courthouse - VA

Kings County Jail - CA

Utah Corrections, UT

Tesoro - UT

San Luis POE, AZ

American Water - PA

Grand Coulee Dam - WA

United Technology - AZ



Model	HydraWedge SM50	HydraWedge SM50 UPS	HydraWedge SM50 Twin	HydraWedge SM50 Twin UPS
Crash Certified	Domestic ASTM F2656-15 M50-P1 and international IWA 14-1 V/7200[N3C]/80/90:0.0 and PAS68 V/7500[N3]/80/90:0.0/20.7 with no penetration † †			
Duty Cycle	300 cycles/hr		400 cycles/hr divided between 2 wedges	
Horsepower	2 hp		5 hp	4 hp
Drive	Hydraulic			
Open/Close Time	3-4 seconds			
Emergency Fast Operate	1 second			
Manual Operation	Hand pump (standard)			
Wedge Design	Plate width: 2, 2.5, 3, 3.5, 4 m* (6.5, 8, 10, 11.5, 13 ft); Plate height (raised): 1000 mm (3.3 ft); Excavation width: Plate width + 700 mm (27.5 inch); Excavation length: 3.7 m (12 ft); Excavation depth:** 300 mm (1 ft)			
Wheel Load	44,000 lb axle load rating; 22,000 lb wheel load			
UPS Battery Backup Cycles	Standard model generates multiple cycles from fully charged accumulator.	DC Power Supply w/HyCharger DC™ provides hundreds of cycles after AC power loss.***	Standard model generates multiple cycles from fully charged accumulator.	DC Power Supply w/HyCharger DC™ provides hundreds of cycles after AC power loss.***
Backup Cycles	4 cycles: 2.5 gallons accumulator	Hundreds of UPS cycles.	4 cycles: 2.5 gallons accumulator	Hundreds of UPS cycles.
Temperature Rating	-40° to 158° F (-40° to 70° C) or -10° to 158° F (-23° to 70° C) HySecurity specified biodegradable fluid			
Single Phase Voltages	208-230V 60Hz, 220V 50Hz*	208-230V 60Hz, 220V 50Hz*, 115V 60/50Hz 23A† or 208-230V 60/50Hz 11.5A. Choose voltage with care as chargers are not field convertible.	230V 60Hz, 220V 50Hz*	115V 50/60Hz 23A† or 208-230V 50/60Hz 11.5A. Choose voltage with care as chargers are not field convertible
Three Phase Voltages	208-230/460V 60Hz, 220/380/440V 50Hz***	N/A	208-230/460V 60Hz, 220/380/440V 50Hz***	N/A
Batteries	Two 8Ah batteries maintain low voltage to the controls for 24 hours after AC power loss	Two 110 Ah batteries located in separate DC UPS enclosure	Two 8Ah batteries maintain low voltage to the controls for 24 hours after AC power loss	Two 110Ah batteries located in the DC UPS enclosure
Communication	RS-232, RS-485			
User Controls	Smart Touch Controller with 70+ configurable settings. Smart Touch keypad and 32 character, OLED display or a PC using S.T.A.R.T. software.			
Relays	Three configurable user relays: one 30VDC, 3A solid state and two 250VAC, 10A electromechanical. Optional Hy8Relay™ for 8 additional relay outputs.			
Enclosure	HydraSupply XL: Type 3R, 91w x 122h x 41d cm (36w x 48h x 16d inch), optional NEMA 4X	HydraSupply XL: Type 3R, 91w x 122h x 41d cm (36w x 48h x 16d inch), optional NEMA 4X; DC Power Supply: Type 3R, 76w x 76h x 30d cm (30w x 30h x 12d inch)	HydraSupply XL: Type 3R, 91w x 122h x 41d cm (36w x 48h x 16d inch), optional NEMA 4X	HydraSupply XL: Type 3R, 91w x 122h x 41d cm (36w x 48h x 16d inch), optional NEMA 4X; DC Power Supply: Type 3R, 76w x 76h x 30d cm (30w x 30h x 12d inch)
Finish	Stone gray powder coated, 2,000 hr salt spray tested			
Foundation	Less than 300 mm** (1 ft) concrete depth all widths up to 4.15 m (13.5 ft); less than 218 kg (480 lb) rebar; less than 3.1 m ³ (4 cu yds) concrete		Less than 300 mm** (1 ft) concrete depth all widths up to 4.15 m (13.5 ft); less than 218 kg (480 lb) rebar; less than 3.1 m ³ (4 cu yds) concrete (per wedge)	
ETL Listed (UL 325)	Control panel certified to UL 508A by ETL			
Warranty	5 year warranty on electronics and hydraulics w/product registration. 2 year warranty on mechanical wedge.			

* Wedge manufactured in metric scale. Use for precision measurements. All imperial measurements rounded to nearest 1/2 ft.

† 115 input requires 30A branch circuit.

†† Ratings: ASTM F2656-15 M50-P1 IWA14- 1: 2013 PAS 68: 2013. Contact HySecurity to receive a copy of the ASTM F2656-15 M50-P1 Test Certification.

** 300 mm excavation: 200 mm reinforcing concrete + 100 mm roadway surface of any material

***The operators normal duty cycle and the actual number of combined cycles available from batteries depends upon wedge plate weight, number of batteries, state of charge and health, ambient temperature, accessory power draw and frequency of gate cycles during power outage.

Optional Accessories Wedge fitted with safety skirt, LED light bar, HY-5B intelligent vehicle detectors, Hy8Relay™, heater and custom color.

System Design Support Contact HySecurity for help with custom site requirements, CAD drawings, tech manuals or other specifications support.

Visit HySecurity Support Page for installation manuals, parts diagrams, wiring diagrams, specifications, image gallery, videos, training and much more.

Easy, Quick, Inexpensive Install

Over 100,000 Industrial and Anti-Ram High Security Sites Worldwide

Install HydraWedge SM50 in 2 days! At less than a foot of structural concrete and with minimal rebar*, a crew of two can complete installation in two days. Then program operation and gate sequencing on site with HySecurity's Smart Touch Controller.

Day 1

- Excavate foundation / drainage
- Attach rebar: ties or tack weld
- Attach sheetmetal drains
- Level excavation
- Lower into excavation
- Level with transit
- Connect conduits
- Mount HydraSupply XL





Day 2

- Connect hydraulic lines
- Connect limit switches
- Pour and finish concrete
(time to cure concrete not included)
- Connect power and controls
- Program site options
- Cycle HydraWedge SM50





support.hysecurity.com

Nice/HySecurity is an industry leader of automated gate and perimeter security solutions.
The HySecurity brand provides high-quality, ultra-reliable industrial gate operators and crash-rated, Hostile Vehicle Mitigation (HVM) vehicle barriers designed to secure and protect critical infrastructure and facilities worldwide.



[Niceforyou.com](https://www.niceforyou.com)

©2023 Nice North America LLC. All rights reserved.
HySecurity is a registered trademark of Nice North America LLC.
All trademarks, logos and brand names are the property of their respective owners.