

SlideDriver™ II

SlideDriver II 15

SlideDriver II 40

SlideDriver II 50F

SlideDriver II 80V

SlideDriver II 200V

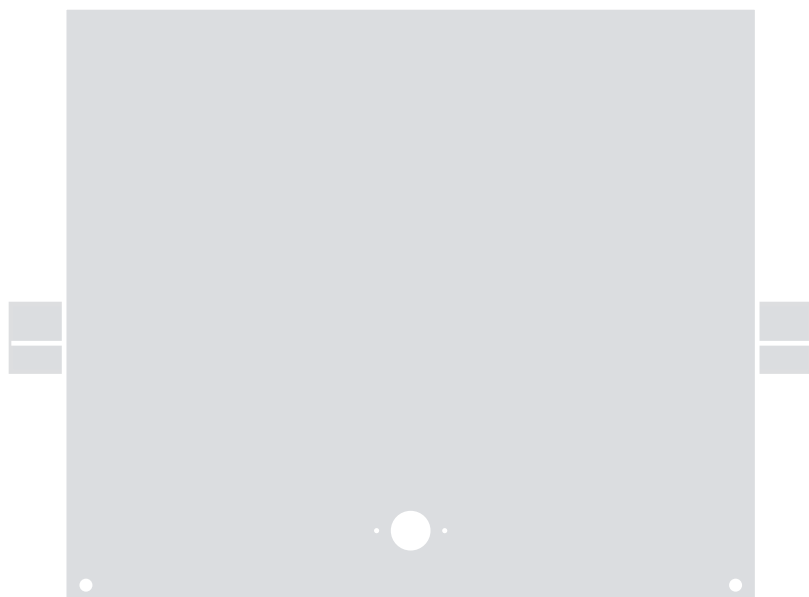

Slide gate operator

EN - User guide

TABLE OF CONTENTS

SlideDriver II All Models

Table of Contents.....	2-11
User Interface	12
Entrapment Sensor Wiring	13
IES Sensitivity.....	14
Maintenance	15-20
Firmware Updates and Debug Data	21
Troubleshooting/Alerts/Faults/Errors ...	22-28
Appendix A - French Translations.....	29-32
Warranty	36
Specifications	37
SlideDriver II Installer Checklist.....	38-39

Scan the QR code below to go to the warranty registration page.



SAFETY MESSAGES

The safety messages below inform you about potential hazards that can result in injury. Safety messages specifically address level of exposure to operator and are preceded by one of four words: **DANGER**, **WARNING**, **CAUTION** or **NOTICE**.

 **DANGER**

Indicates a hazardous situation which, if not avoided, **WILL** result in **DEATH** or **SERIOUS INJURY**.

 **WARNING**

Indicates a hazardous situation which, if not avoided, **COULD** result in **DEATH** or **SERIOUS INJURY**.

 **CAUTION**



Indicates a hazardous situation which, if not avoided, **COULD** result in **MINOR** or **MODERATE INJURY**.

NOTICE

Addresses practices not related to personal injury. Indicates damage to equipment is probable if the hazardous situation is not avoided.

COMMON INDUSTRIAL SYMBOLS

These international safety symbols may appear on product or in its literature to alert of potential personal injury hazards. Obey all safety messages that follow these symbols to avoid possible injury or death.

Symbol	Safety Hazard
	Attention - Take Notice
	Danger - Keep Away
	Entrapment Zone
	Possible Pinch Point

IMPORTANT SAFETY INSTRUCTIONS

Hazards, associated with automatic gates, can be reduced with proper site design, installation, and use. Installers, maintenance crews, and owners/users must read and follow the safety requirements found in HySecurity® product manuals.



It is important that only qualified installers handle installation of HySecurity Gate vehicular gate operators. A “qualified” installer has one of the following:



1. A minimum of three years experience installing similar equipment.
2. Proof of attending a HySecurity Technical Training seminar within the past three years.
3. Significant manufacturer endorsements of technical aptitude in gate operator installation and operation.

Underwriter Laboratories (UL) and the American Society for Testing and Materials (ASTM) are responsible for current safety standards and regulations regarding gate operators and automated gates. All aspects of gate installation must comply with the appropriate safety standard. For the most up-to-date ASTM F2200 Gate and Fence Standards, refer to www.astm.org. For UL 325 Safety Standard, refer to www.ul.com. Consult local government agencies for up-to-date rules and regulations as certain municipalities have established licensing, codes or regulations that regulate automated gate system design and installation.

GENERAL SAFETY INFORMATION

A gate operator is only a component in a gate system. The other parts of the gate system can include the gate, the external safety sensors, access controls, and vehicle detectors. To have a gate system that provides for safety, security, and reliable operation it is essential these components operate together as a system. It is the responsibility of the system designer and/or installer to ensure any safety or operational issues have been addressed.

*Disclaimer: All gate installations using HySecurity vehicular gate operators must comply with UL325 and ASTM F2200 safety standards in addition to any local area codes and standards. Site, gate hardware, usage class, and other conditions will dictate the use of additional safety designs and components. All safety related warnings and notices in this document, and any diagrams, drawings, photographs and similar content should not be considered guidance on how to make your particular site safe and code compliant. It is the responsibility of the gate system designer, installer and owner to assess appropriate safety design considerations, correct implementation and ongoing maintenance of any system.

SAFETY REQUIREMENTS

WARNING

To reduce the risk of injury or death:

1. READ AND FOLLOW ALL INSTRUCTIONS.
2. Never let children operate or play with gate controls. Keep the remote control away from children.
3. Always keep people and objects away from the gate. **NO ONE SHOULD CROSS THE PATH OF THE MOVING GATE.**
4. Test the gate operator monthly. The gate **MUST** reverse on contact with a rigid object or stop when an object activates the non-contact sensors. After adjusting the force or the limit of travel, retest the gate operator. Failure to adjust and retest the gate operator properly can increase the risk of injury or death.
5. Use the emergency release only when the gate is not moving.
6. **KEEP GATES PROPERLY MAINTAINED.** Read the user's manual. Have a qualified service person make repairs to gate hardware.
7. The entrance is for vehicles only. Pedestrians must use separate entrance.
8. **SAVE THESE INSTRUCTIONS.**

IDENTIFYING GATE OPERATOR CATEGORY AND UL 325 USAGE CLASS

The UL 325 standard covers gate operators. Within this safety standard several Usage Classes are described that define different types of installations where gate operators can be applied. Some operators are restricted in their usage application. Appropriate Usage Classes are shown in the Specifications.

Class I



Class I: Intended for use in a location of one to four single family dwellings or a parking area associated with one to four single family dwellings.

Class II



Class II: Intended for use in a commercial location or building such as a multi-family housing units (five or more single family units) hotels, garages, retail stores or other buildings servicing general public.

Class III

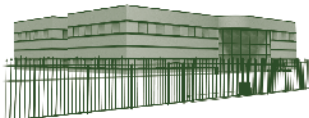

Class III: Intended for use in an industrial location or building such as factories or loading docks or other locations not accessible by the general public.

Class IV



Class IV: Intended for use in guarded industrial locations or buildings such as an airport security area or other restricted access location, not servicing general public, in which access is monitored by security personnel or via closed circuitry.

VEHICULAR TRAFFIC ONLY



WARNING

This automatic gate operator is not designed nor is it intended for pedestrian traffic. Vehicular gate operators must by their nature be powerful to function reliably. This power can cause injury or death. Accordingly, direct all pedestrian traffic to a separate walk-through gate.

Install this gate operator only when:

- The operator is appropriate for the construction of the gate and the Usage Class of the site.
- All openings of a horizontal slide gate are guarded or screened from the bottom of the gate to a minimum of 1.83 m (6 ft) above the ground to prevent a 57.2 mm (2-1/4 in) diameter sphere from passing through the openings anywhere in the gate, and in that portion of the adjacent fence that the gate covers in the open position.
- All exposed pinch points are eliminated or guarded.
- Guarding is supplied for exposed rollers.

The operator is intended for installation only on gates used for vehicles. Pedestrians must be supplied with a separate access opening. The pedestrian access opening shall be designed to promote pedestrian usage. Locate the gate such that persons will not come in contact with the vehicular gate during the entire path of travel of the vehicular gate.

The gate must be installed in a location so that enough clearance is supplied between the gate and adjacent structures when opening and closing to reduce the risk of entrapment. Swinging gates shall not open into public access areas.

The gate must be properly installed and work freely in both directions prior to the installation of the gate operator. Do not over-tighten the operator clutch or pressure relief valve to compensate for an improperly installed, improperly functioning, or damaged gate.

Permanently mounted controls intended for user activation must be located at least 1.83 m (6 ft) away from any moving part of the gate and where the user is prevented from reaching over, under, around or through the gate to operate the controls.

- Exception: Emergency access controls only accessible by authorized personnel (e.g. fire, police, EMS) may be placed at any location in the line-of-sight of the gate.

The Stop and/or Reset button must be located in the line-of-sight of the gate. Activation of the reset control shall not cause the operator to start.

A minimum of two (2) WARNING SIGNS shall be installed, in the area of the gate. Each placard is to be visible by persons located on the side of the gate on which the placard is installed.

For gate operators utilizing a non-contact sensor (Photo Eye):

- See instructions on the placement of non-contact sensors for each type of application.
- Care shall be exercised to reduce the risk of nuisance tripping, such as when a vehicle trips the sensor while the gate is still moving.
- One or more non-contact sensors shall be located where the risk of entrapment or obstruction exists, such as the perimeter reachable by a moving gate or barrier.

For a gate operator utilizing a contact sensor (Edge):

- One or more contact sensors shall be located where the risk of entrapment or obstruction exists, such as at the leading edge, trailing edge, and postmounted both inside and outside of a vehicular horizontal slide gate.
- A hardwired contact sensor shall be located and its wiring arranged so that the communication between the sensor and the gate operator is not subjected to mechanical damage.
- A wireless device that transmits radio frequency (RF) signals to the gate operator for entrapment protection functions shall be located where the transmission of the signals are not obstructed or impeded by building structures, natural landscaping or similar obstruction. A wireless device shall function under the intended end-use conditions.
- One or more contact sensors shall be located on the inside and outside leading edge of a swing gate. Additionally, if the bottom edge of a swing gate is greater than 152 mm (6 in) but less than 406 mm (16 in) above the ground at any point in its arc of travel, one or more contact sensors shall be located on the bottom edge.

USE OF VEHICLE DETECTORS

Use of vehicle detectors (loop detectors) is strongly encouraged to prevent damage to vehicles caused by gates closing on them. This is not considered to be a safety item as most vehicle detectors cannot provide protection to pedestrians. In some situations, photoelectric devices may be used as vehicle detectors, but should be wired accordingly.

GATE CONSTRUCTION AND SAFETY

Gate construction plays a very important role in ensuring the safety of any automated gate system. The standard for gate construction is ASTM F2200. Below are key areas to address in gate design for safety. For complete information consult the standard. Copies of the standard are available at: <https://www.astm.org/Standards/F2200.htm>.

SAFETY REQUIREMENTS

Another source of information is available from DASMA, the Door and Access System Manufacturer's Association. The Association publishes Technical Data Sheets, one of which concerns ASTM F2200. For more information, see:

<http://www.dasma.com/PDF/Publications>

General Requirements for gate construction:

- Gates shall be constructed in accordance with the provisions given for the appropriate gate type listed. Refer to ASTM F2200 for additional gate types.
- Gates shall be designed, constructed and installed to not fall over more than 45 degrees from the vertical plane, when a gate is detached from the supporting hardware.
- Gates shall have smooth bottom edges, with vertical bottom edged protrusions not exceeding 0.50 in (12.7 mm) other than the Exceptions listed ASTM F2200.
- The minimum height for barbed wire shall not be less than 6 ft (1.83 m) above grade. The minimum height for barbed tape shall not be less than 8 ft (2.44 m) above grade.
- An existing gate latch shall be disabled when a manually operated gate is retrofitted with a powered gate operator.
- A gate latch shall not be installed on an automatically operated gate.
- Protrusions shall not be permitted on any gate. Consult ASTM F2200 for exceptions.
- Gates shall be designed, constructed and installed such that their movement shall not be initiated by gravity when an automatic operator is disconnected.
- For pedestrian access in the vicinity of an automated vehicular gate, a separate pedestrian gate shall be provided. The pedestrian gate shall be installed in a location such that a pedestrian shall not come in contact with a moving vehicular access gate. A pedestrian gate shall not be incorporated into an automated vehicular gate panel.
- Any non-automated gate that is to be automated shall be upgraded to conform to the provisions of this specification.
- This specification shall not apply to gates generally used for pedestrian access and to vehicular gates not to be automated.
- Any existing automated gate, when the operator requires replacement, shall be upgraded to conform to the provisions of this specification in effect at that time.

The following provisions shall apply to Class I, Class II, Class III, and Class IV vehicular horizontal slide gates:

All weight bearing exposed rollers 8 ft (2.44 m), or less, above grade shall be guarded or covered.

All openings shall be designed, guarded, or screened from the bottom of the gate to the top of the gate or a minimum of 72 inch (1.83 m) above grade, whichever is less, to prevent a 2-1/4 inch (57 mm) diameter sphere from passing through the openings anywhere in the gate, and in that portion of the adjacent fence that the gate covers in the open position. The gate panel shall include the entire section of the moving gate, including any back frame or counterbalance portion of the gate.

A gap, measured in the horizontal plane parallel to the roadway, between a fixed stationary object nearest the roadway (such as a gate support post) and the gate frame when the gate is in either the fully open position or the fully closed position, shall not exceed 2-1/4 inches (57 mm).

Exception: All other fixed stationary objects greater than 16 inches (406 mm) from the gate frame shall not be required to comply with this section.

Positive stops are provided to limit travel to the designed fully open and fully closed positions. These stops shall be installed at either the top of the gate, or at the bottom of the gate where such stops shall horizontally or vertically project no more than is required to perform their intended function.

All gates shall be designed with sufficient lateral stability to assure that the gate will enter a receiver guide. Consult ASTM F2200 for details on various gate panel types.

EXTERNAL ENTRAPMENT PROTECTION SENSORS

Most HySecurity gate operators are equipped with a Type A, Inherent Entrapment Sensor (IES). UL 325 Safety Standard compliance requires installation of external entrapment protection sensors, the number of which, depends on entrapment hazards that exist at each particular installation.

To comply with UL 325, the following external sensors may be used:

- Contact sensors, such as edge sensors
- Non-contact sensors, such as photo eyes

Site designer or installer can choose either photo eyes, edge sensors, or a combination of these devices.

UL 325 Safety Standard for automatic sliding gates specifically requires that edge sensors, photo eyes, or a combination of both devices be installed to protect against pedestrian entrapment in BOTH directions of gate travel and wherever entrapment hazards exist.

UL 325 LISTING: Edge sensors and photo eyes must be tested and labeled as “Recognized Components” or otherwise certified to UL 325 requirements in order to be deemed acceptable for use in a gate operator. Study Important Safety Instructions and consider your specific installation to determine where greatest entrapment risks exist. Locate edge sensors and/or photo sensors accordingly. Be certain that a sufficient number of sensors are used so that pedestrians are protected from entrapment in both directions of gate travel and all hazard areas are fully protected. Most HySecurity gate operators require external entrapment sensors that utilize Normally Closed (NC) contact means of monitoring. HySecurity gate operators utilizing the SmartCNX Controller or the SmartTouch 720/725 Controller require external entrapment sensors that have a 10k Ohm or 4-wire pulsed monitoring scheme. Refer to UL website at www.ul.com for most up-to-date list of gate operator safety standards (UL 325). Refer to www.astm.org for a complete list of ASTM F2200 Gate and Fence Standards.



Recommended External Entrapment Protection Sensors List

The following sensors have been tested with Nice | HySecurity gate operators by an independent laboratory and certified to comply with UL 325 7th Edition. Select sensors from this list for UL compliant gate automation solutions. Contact the sensor manufacturer for specific recommendations for use.

UL 325 Standard:

- The operator shall monitor for the presence of every device at least once during each open and close cycle (32.1.8)
- It shall not be possible to make simple modifications in the field by adding, suppressing or changing, either on the operator or external entrapment protection device(s), to bypass, interfere with, or otherwise defeat the monitoring function. (32.1.10)
- Entrapment zones are now defined for each gate type (4.23, 4.24, 4.29, 4.34)

Slide Gates: To enable fully automatic operation, all SLIDE gate operators will require a minimum of TWO monitored external entrapment protection sensors (one for each direction) to protect entrapment zones in both the open and close direction of travel.

Preferred solution for slide gates: A photo eye for the close direction and a hard-wired edge sensor for the open direction that is mounted to the face of the leading post of the fence behind the gate. (Reach through injuries are the most common hazard associated with automatic sliding gates)

Swing Gates: To enable fully automatic operation, all SWING gate operators will require a minimum of ONE monitored external entrapment protection sensor to protect entrapment zones in either the open or close direction of travel. However, an additional monitored sensor is required if there is a risk of entrapment in both directions of gate travel.

Preferred solution for swing gates: A photo eye for the close direction and/or a hard-wired wraparound edge sensor on the leading edge of the gate, which protects for both directions of gate travel.

SAFETY REQUIREMENTS

	Mfg. Part # or Model	Brand	Nice Hysecurity Part #	Max Range	Smart Touch	Smart DC	SmartCNX	1050	Mercury 310
Photo Eyes (Retro-reflective)	E3K-R10K4-NR-1	Omron	MX000999	40 ft	•	•	•		
	NIR-50-325	EMX	-	45 ft	•	•	•	•	•
	IRB-RET	EMX	-	53 ft	•	•	•	•	•
	E-931-S50RRGQ	Seco-Larm	-	46 ft	•	•	•		•
Photo Eyes (Thru-Beam)	Blue Bus Era Photo Eyes	Nice HySecurity	EPMB/A EPMOB/A EPLOB/A EPMAB/A EMBORB/A	45 ft			•	•	•
	OVS-50TNR	Optex	-	33 ft	•	•			
	IRB-MON	EMX	MX3990	65 ft	•	•	•		•
	E-960-D90GQ	Seco-Larm	-	90 ft	•	•	•		•
Edge Sensors	Sentir Series	ASO Safety	"AS1502- AS1501-"		•	•	•	•	•
	CPT210-2U-#-T2	Miller Edge	-		•	•	•	•	•
Edge Sensor Converters	Hy2NC (Converts 10K to NC Monitoring)	HySecurity	MX4018		•	•			
	GEM103 (Converts 10K to Pulsed Monitoring)	Miller Edge	-					•	
Edge Wireless Kits	iGAZE RE Kit	Transmitter Solutions	-		•	•	•	•	•
	WEL-200	EMX	-		•	•	•	•	•
Multi-Input Module	The Solution – MIM-62	Miller Edge	-		•	•	•		•

Installers must assess each specific site and install sensors that protect all potential entrapment zones.

For more information visit Safety or see latest operator manuals at support.hysecurity.com

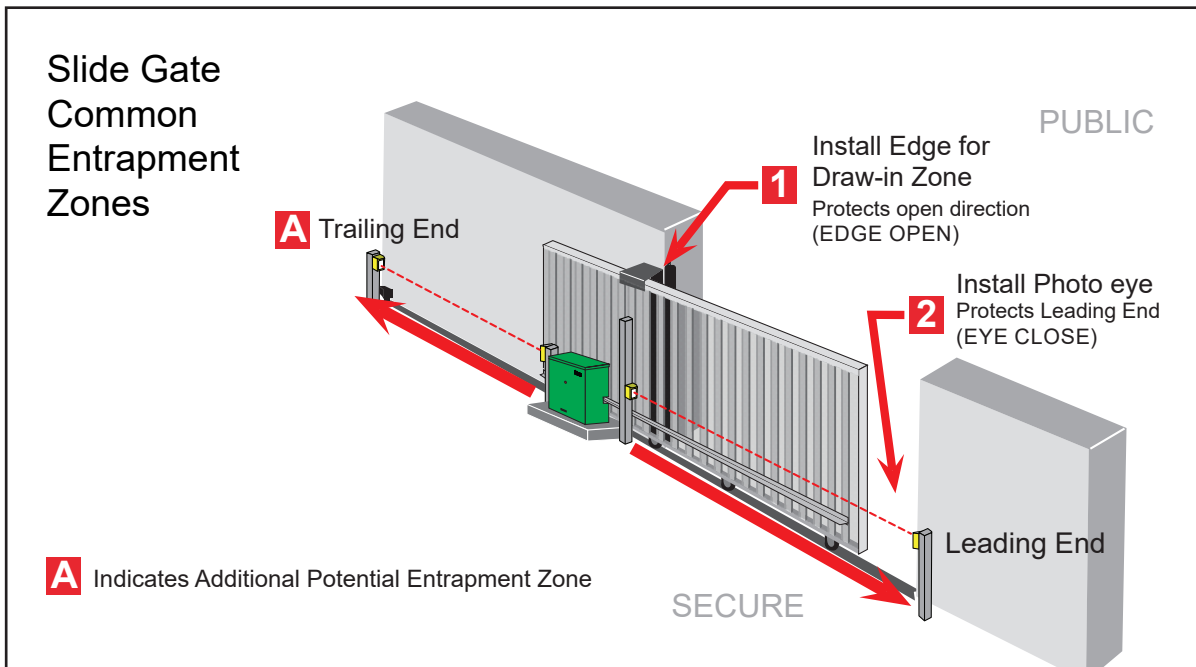

ELECTRICAL SAFETY

- Turn gate operator and all circuit breakers OFF before performing maintenance on the gate operator or making contact with output receptacles.
- Never insert any objects into output receptacles during operation. The possibility exists of electrical shock, electrocution, or death.
- Never let power wires lay in water.
- Never use damaged or worn wire when connecting equipment. Inspect for cuts in the insulation.
- Never grab or touch a live power cord or cable with wet hands. The possibility exists of electrical shock, electrocution or death.
- Always make certain that proper power has been selected for the job. See Cable Selection Chart in this manual.

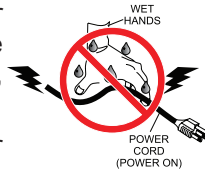

GROUNDING SAFETY

- Always make sure that electrical circuits are properly grounded to a suitable earth ground (ground rod) per the National Electrical Code (NEC) and local codes. Severe injury or death by electrocution can result from operating an ungrounded operator.
- Never use gas piping as an electrical ground.



BATTERY SAFETY

HySecurity operators use sealed Absorbed Glass Mat (AGM) batteries and HySecurity highly recommends replacing used batteries with new AGM-type batteries.

CAUTION

Batteries used with HySecurity gate operator contain materials considered hazardous to environment. Proper battery disposal is required by federal law. Refer to *Hazardous Waste Regulations* federal guidelines.

To reduce risk of fire or injury to persons:

- Observe polarity between batteries and charging circuit.
- Never mix battery sizes, types, or brands. Charging circuit on HySecurity DC operators is designed for AGM-type batteries, not flooded lead acid-type batteries.
- Exercise care in handling batteries. Be aware metal found in rings, bracelets, and keys can conduct electricity, short batteries, and cause potential injury.
- Do not open or mutilate batteries. Battery cells contain corrosive materials which may cause burns and other injuries. Material within batteries is toxic.
- Always dispose of batteries properly. Do not place batteries in fire. Battery cells may explode. Follow federal guidelines for proper disposal of hazardous waste.
- Always keep battery cables in good working condition. Repair or replace all worn cables.
- Replace batteries according to instructions found in *DC Battery Replacement*.
- Do not charge frozen battery. Battery can explode. If frozen, warm the battery to at least 61°F (16°C).



ENVIRONMENTAL SAFETY/HAZARDOUS MATERIALS AND PROPER DISPOSAL

Decommissioning is a controlled process used to safely retire a piece of equipment that is no longer serviceable. If the equipment poses an unacceptable and unreparable safety risk due to wear or damage or is no longer cost effective to maintain (beyond life-cycle reliability) and is to be decommissioned (demolition and dismantlement), be sure to follow rules below.



- Do not pour waste or oil directly onto the ground, down a drain or into any water source.
- Contact your country's Department of Public Works or recycling agency in your area and arrange for proper disposal of any electrical components, waste or oil associated with this equipment.
- When the life cycle of this equipment is over, remove battery and bring to appropriate facility for lead reclamation. Use safety precautions when handling batteries that contain sulfuric acid.
- When the life cycle of this equipment is over, it is recommended that the frame and all other metal and plastic parts be sent to a recycling center.

Metal and plastic recycling involves the collection of metal and plastic from discarded products and its transformation into raw materials to use in manufacturing a new product.

Recyclers and manufacturers alike promote the process of recycling metal and plastic. Using a metal and plastic recycling center promotes energy cost savings.

SAFETY REQUIREMENTS

WIND LOAD FACTORS & SITE PREP

Wind load is always a factor when considering the appropriate gate for a particular site. Solid gate panels produce a larger wind load than gates with slats or open decorative features. If you are installing a gate operator in a high wind area, gate design will affect the load on the gate operator because wind load acts the same as an obstruction. Good gate panel design presents a low surface area to reduce the wind load.

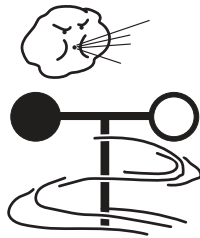

If gate is heavy and near weight capacity of what the gate operator can handle (see specifications), make sure it has an open design that allows wind to flow through it. A solid or semi-solid gate design under certain wind load conditions may cause damage to gate operator and is not covered by the HySecurity Limited Warranty.

Several factors play into calculations of wind load on a gate panel. To find out maximum wind speed in areas around the United States, search for US government wind speed maps on the internet. If you don't know how to calculate for wind load, ask a mechanical engineer or site architect for assistance prior to installing gate operator and gate panels.

When the IES trips, it sends a signal to gate operator to stop and reverse direction. This feature may be falsely triggered in excessively windy conditions because wind itself, acting over surface area of gate panel, can provide necessary force to trigger IES.

CAUTION

Do not adjust IES sensitivity to accommodate for inappropriately designed gate panels. Loss of IES sensitivity increases mechanical wear on gate hardware and gate operator. It may also pose a safety hazard. Compensating for wind loads by adjusting IES may set IES sensitivity to a level which, when encountering an obstruction, ignores obstruction and fails to reverse direction. For more information, refer to Adjusting the IES Sensitivity.

MAINTENANCE OF GATE SYSTEMS

To keep your automated gate system performing both safely and reliably it is important to ensure that the components of that system are functioning properly.

At least monthly:

- Disconnect the gate operator and manually move the gate through its range of travel. Note any squeaks from rollers or hinges or areas of binding. The gate should travel smoothly and quietly throughout its range. If it does not, contact a gate professional to correct the problem.
- Reconnect the gate operator and perform the following tests:
 - With the gate opening, block any photo eyes and/or depress any safety edges used to protect the open direction. The gate should stop and/or reverse.
 - With the gate closing, block any photo eyes and/or depress any safety edges used to protect the close direction. The gate should stop and/or reverse.
 - Using a suitable obstruction in the path of the gate (a solid, immovable object), run the gate in the open direction until it contacts the obstruction. The gate should stop and reverse.
 - Using a suitable obstruction in the path of the gate (a solid, immovable object), run the gate in the close direction until it contacts the obstruction. The gate should stop and reverse.

STOP BUTTON

The stop button clears entrapment mode and resets some faults, errors, and alarms.

The external stop button for the SlideDriver II is located on the right side of the chassis.

Press the stop button while the gate is opening or closing to stop gate travel and disable the automatic close timer. The operator requires a new open or close command to resume function.

Inform all users of the location of the stop button and its function.

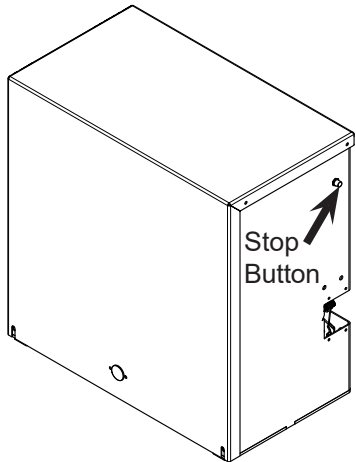

Figure 1. Stop Button

EMERGENCY RELEASE

Teach all users how to turn off electric power and manually move the gate.

To manually release the gate:

1. Remove the cover.

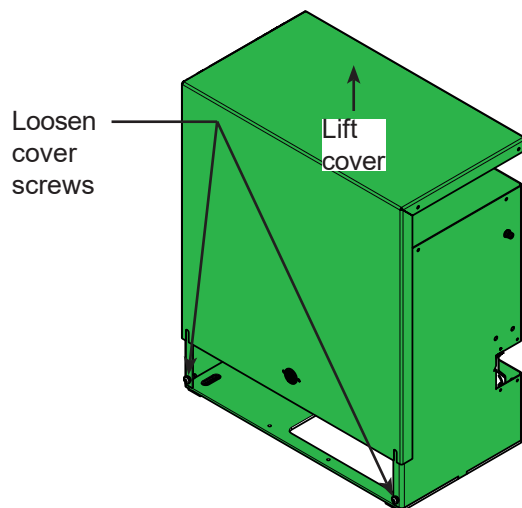

Figure 2. Remove the cover

2. Set the power switch to OFF.
3. Unclamp the toggle handle and secure it in the unclamped position.
4. Manually push the gate open or close.

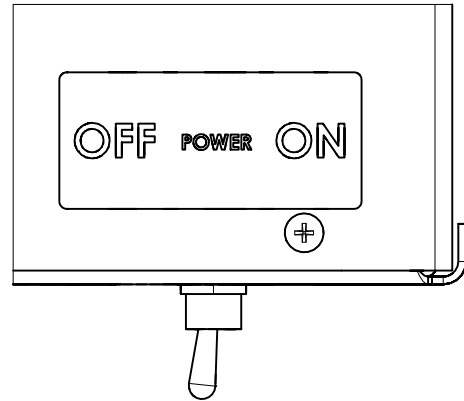

Figure 3. Power Switch Set to OFF

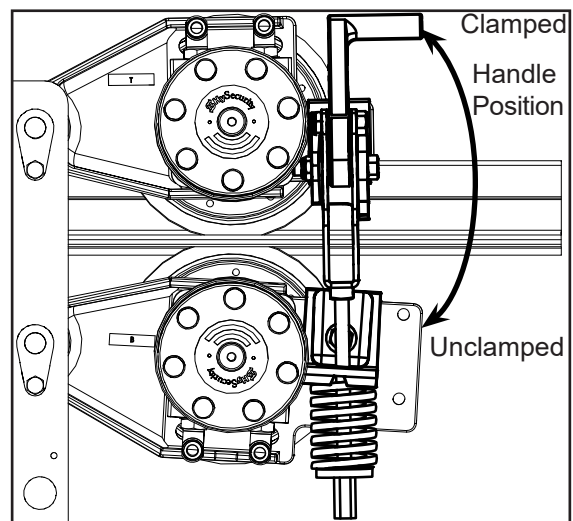

Figure 4. Slide the Gate Manually

To return SlideDriver II to automatic operation, follow these steps:

1. Clamp the toggle handle.
2. Set the power switch to ON.
3. Press STOP or RESET to clear any faults.
4. Attach the front cover.

⚠ WARNING

When releasing the handle inside the chassis, be careful as the mechanism is spring-loaded and drops rapidly. Grasp the toggle handle firmly so your fingers do not get pinched, hit, or crushed.

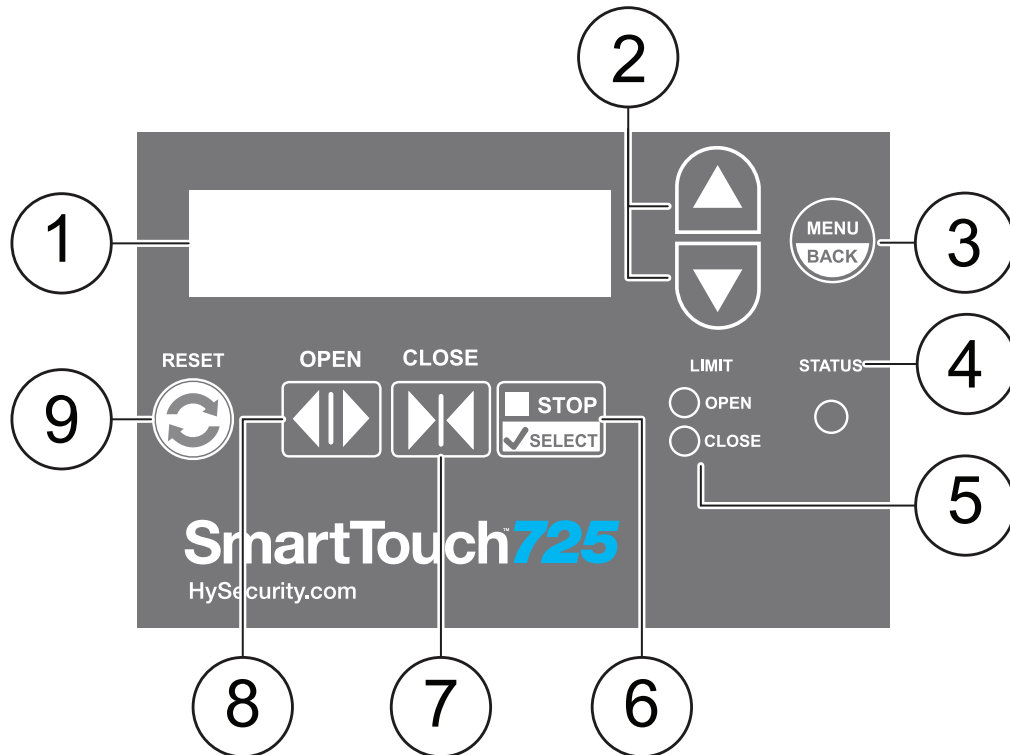
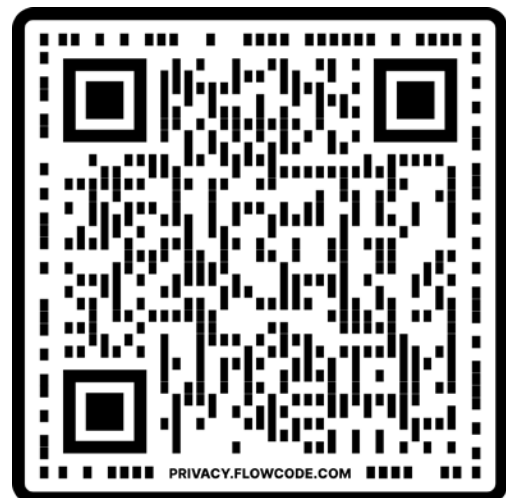

Figure 5. SmartTouch 720/725 Controller User Interface

1. **OLED Display** – 16 characters per line, 2 line display. Displays current operator status, menus, and alerts/faults/errors. In h6.03 and later firmware, the display will shut off when none of the on board buttons have been pressed for a while. Pressing any button will turn it back on. This is to save power and extend the life of the display.
2. **Up/Down Arrows** – Navigate through menu and display options while in Menu Mode.
3. **Menu/Back** – Open the configuration menu from the operator status display. Go back from the current menu (exit the current menu).
4. **Status LED** – Indicates gate operator status
 - a. Flashing Red – An Alert, Fault, or Error has occurred. Immediately shut down the machine and correct the fault.
 - b. Solid Red – Operator is in Menu Mode
 - c. Flashing Green – Operator is in Run Mode
 - d. Flashing Blue – Operator is pairing with a Bluetooth device.
 - e. Alternating Blue and Red/Green – Operator is communicating with a Bluetooth device.
5. **Limit Open/Close** – Solid green when limit flag activates limit sensor.
6. **Stop/Select** – Stops gate travel when in run mode. Press to select current menu option or to confirm setting value
7. **Close** – Closes the gate while in Run Mode.
8. **Open** – Opens the gate while in Run Mode.
9. **Reset** – Press to clear faults and return to Run Mode. Not functional in Menu Mode.

HySecurity Installer App QR Code



ENTRAPMENT SENSOR WIRING

HySecurity provides one edge sensor typically used as hardwired EDGE OPEN and one photo eye typically used as EYE CLOSE with the SlideDriver II 15, 40, 50F, and 80V.

Install the entrapment sensor:

1. Set power switch to OFF.
2. Install the entrapment sensor in an appropriate location for entrapment protection (page 8).
3. Route the wires to the inside of the SlideDriver II chassis.
4. Install the wires into input Sensor #1, Sensor #2, or Input #1, Input #2, or Input #3 on the SmartTouch 720/725 Controller (Figure 6).

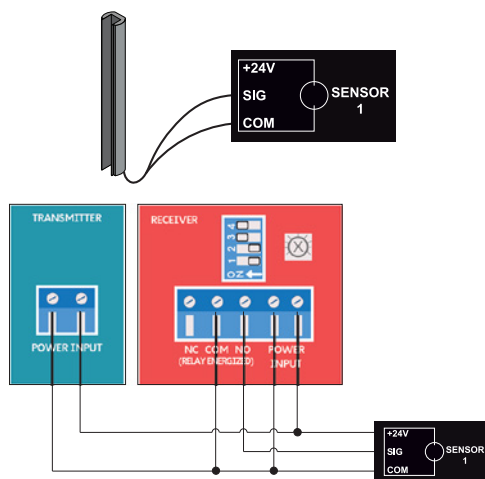

Figure 6. Bundled Sensor Connections

5. Set power switch to ON.
6. In PROGRAMMABLE INPUTS menu, select the SENSOR TYPE or INPUT TYPE for each external entrapment sensor. The indicator LED changes to green when sensor is activated or not installed correctly.
7. In ENTRAPMENT SENSOR RESPONSE menu, set the desired response action for each entrapment type.
8. Test the function of each sensor.

Install a non-BlueBUS photo eye:

Additional photo eyes can connect to the SmartTouch 720/725 Controller terminals Sensor #1 - #2 and Input #1 - #3. Follow the same instructions for an edge sensor (Figure 6).

Set any DIP-switches and jumpers according to manufacturer instructions for 10k output.

Make sure to connect to a Sensor COM port for switched common for monitoring purposes.

† = Indicates default

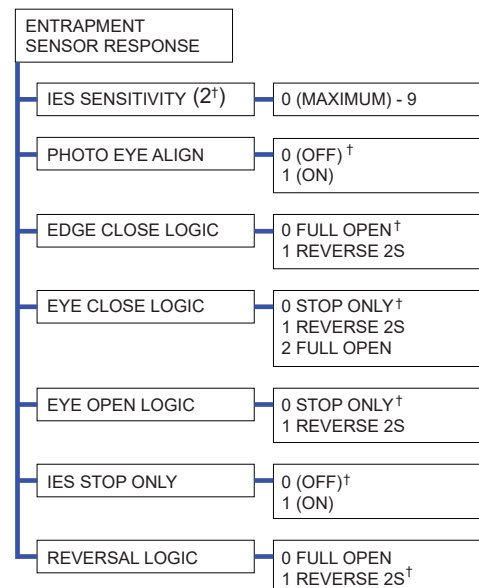
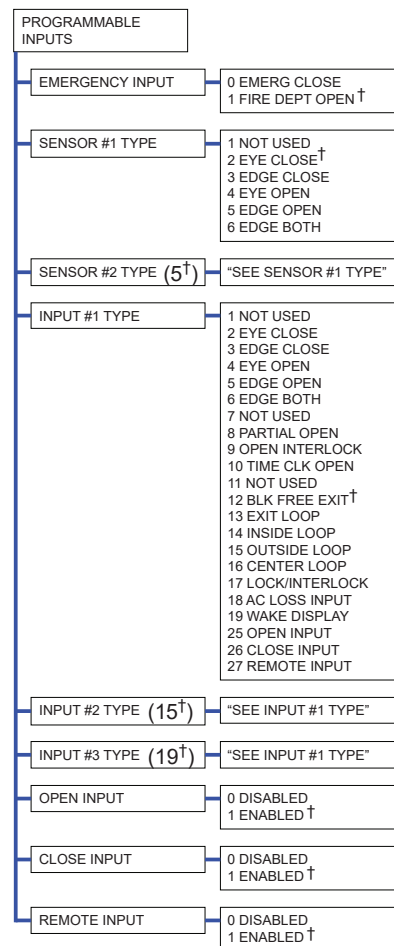

Note: When Photo Eye Align mode is turned on, the display will show all the sensor inputs that are programmed for photo eyes and will show if they are active or not (a 1 indicates the eye is present and aligned and a 0 indicates the eye is not aligned or blocked). Any BlueBUS eye will also show up on the display.

IES SENSITIVITY

To comply with UL 325 Safety Standards, SlideDriver II operators are equipped with a Type A, Inherent Entrapment Sensor (IES). The firmware monitors the hydraulic pressure when a gate is in motion and reverses direction of gate travel when the pressure exceeds a self-adapting threshold. A spike in hydraulic pressure can be caused by the gate hitting a pedestrian, a collision with a vehicle, failing gate hardware, extreme wind gust, or any other force applied against the moving gate. To set the IES sensitivity for your site follow these instructions:

1. Press MENU on the SmartTouch 720/725 Controller.
2. Press the UP or DOWN arrow to navigate to ENTRAPMENT SENSOR RESPONSE, press SELECT.
3. Press the UP or DOWN arrow to navigate to IES SENSITIVITY, press SELECT.
4. Press the UP or DOWN arrow to choose an IES SENSITIVITY, press SELECT to update the setting.
5. Press BACK until the display shows the operator status.
6. Run the operator for 3 uninterrupted gate cycles so the IES can adapt to the new setting.
7. Apply force to the leading edge of the moving gate with an immovable obstruction to trigger the IES. Gate will stop motion and reverse for at least two seconds. "SAFE MODE" appears on the display.

WARNING

Do not enter the path of gate travel to test IES sensitivity. Vehicular gate operators must by their nature be powerful to function reliably. This power can cause injury or death to people caught in the moving gate.

8. Cycle the gate a few times to test the IES sensitivity.

Note: The default IES SENSITIVITY of 2 should be sufficient for most sites.

Note: In Safe Mode, the automatic close timer is disabled, but any open or close input restarts gate motion. Safe Mode clears when full travel reached or Reset button pushed.

Note: A second IES trip before Safe Mode is cleared, results in an Entrapment Mode Alert which can be cleared with a Reset on the display, an open input, stop input, or stop button on SlideDriver II cover.

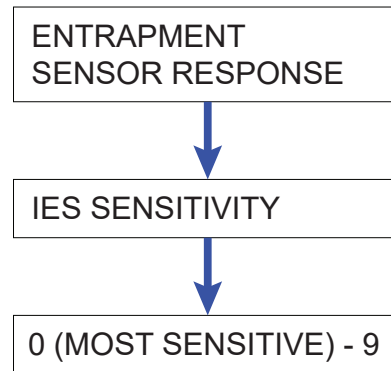

MECHANICAL MAINTENANCE

CAUTION

Before checking internal mechanisms of operator, turn off all power switches.

SlideDriver II mechanical maintenance should be performed on a routine basis. The standard operator chassis has zinc based corrosion protection, but some environments may speed corrosion.

Schedule regular maintenance and look for the following:

- Verify center clamp has proper compression (see page 17). Check for drive wheel wear and damage. Fraying edges or galling indicate that the wheels are due for replacement.
- Check for signs of rust. If any areas of rust are found, reduce spread of corrosion by treating areas with a rust inhibitor.

SLIDEDRIVER OPERATOR MAINTENANCE SCHEDULE

Name of part	What to do	Check at these recommended monthly intervals				
		1	3	6	12	24
Gate and hardware	Check for damage and wear *1	X				
Drive rail	Check for proper alignment *2		X			
Wheel clamp spring	Check for clamping tension *3		X			
Drive wheels	Check for tightness and wear *4		X			
Dual limit sensor	Check for proper alignment *5		X			
Limit flags	Check for proper alignment *5			X		
Anchor bolts	Check for tightness			X		
Fluid level	Check for loss of fluid *6				X	
Hydraulic fluid	Drain and replace fluid *6					X
Motor Brushes (DC Only)	Replace *7					X

1. Your gate and gate hardware will require more maintenance than your HySecurity operator. A damaged gate or worn hardware may cause slow or erratic operation and will result in excess drive wheel wear. Lubricate gate hardware more frequently and check for smooth operation by opening the toggle clamping mechanism and then pushing the gate manually. One person should easily be able to push all but the largest of gates. Damaged or warped gate panels should be straightened or replaced.
2. See "Drive Rail" on page 16.
3. See "Drive Wheel Spring Tension (Adjustment of Manual Release)" on page 17.
4. Normally, drive wheel life is many years. They are designed to avoid slipping on the rail. Drive wheel life may be greatly shortened by any of these faults: clamping spring not adjusted correctly, operator or drive rail misaligned in relation to gate panel, badly warped gate panel, extremely stiff gate hardware, brake valves set to stop too fast, and/or loose wheel mounting bolts (tighten to 18 ft-lb).
5. The dual limit sensor should be spaced $\frac{1}{4}$ to $\frac{3}{4}$ in (6 to 19 mm) away from the limit flags and vertically centered over the limit flags. Maladjustment may result in false or early tripping or no limit function at the end of travel. Verify that the limit flags are tightly bolted to the drive rail. Verify the limit sensors are snug in their mounts.
6. See "Hydraulic System Maintenance" on page 19.
7. DC Operators use DC motors with 4 carbon brushes which wear in normal operation. Worn brushes can damage the DC motor. Under severe conditions HySecurity recommends that brushes be checked after 2 years or 250,000 cycles and the replacement interval be adjusted as necessary.

MAINTENANCE

Drive Rail

Verify that the drive rail does not move down, more than 1 in up, or ¼ in side-to-side throughout the entire horizontal travel of the gate.

NOTICE

The drive rail must not move down or it will rub against the dual limit sensor(s). Adjust the drive rail so it does not rub on the dual limit sensor(s).

To adjust the rail for side-to-side movements, loosen the U-bolts and insert or remove shims between the rail and the gate where necessary.

To adjust up or down, loosen the U-bolts and tap the rail with a hammer until the correct height is reached.

If using XtremeDrive wheels, the height of the drive rail needs to be set between 9½ in to 10 in (235 to 255 mm) from base of SlideDriver chassis.

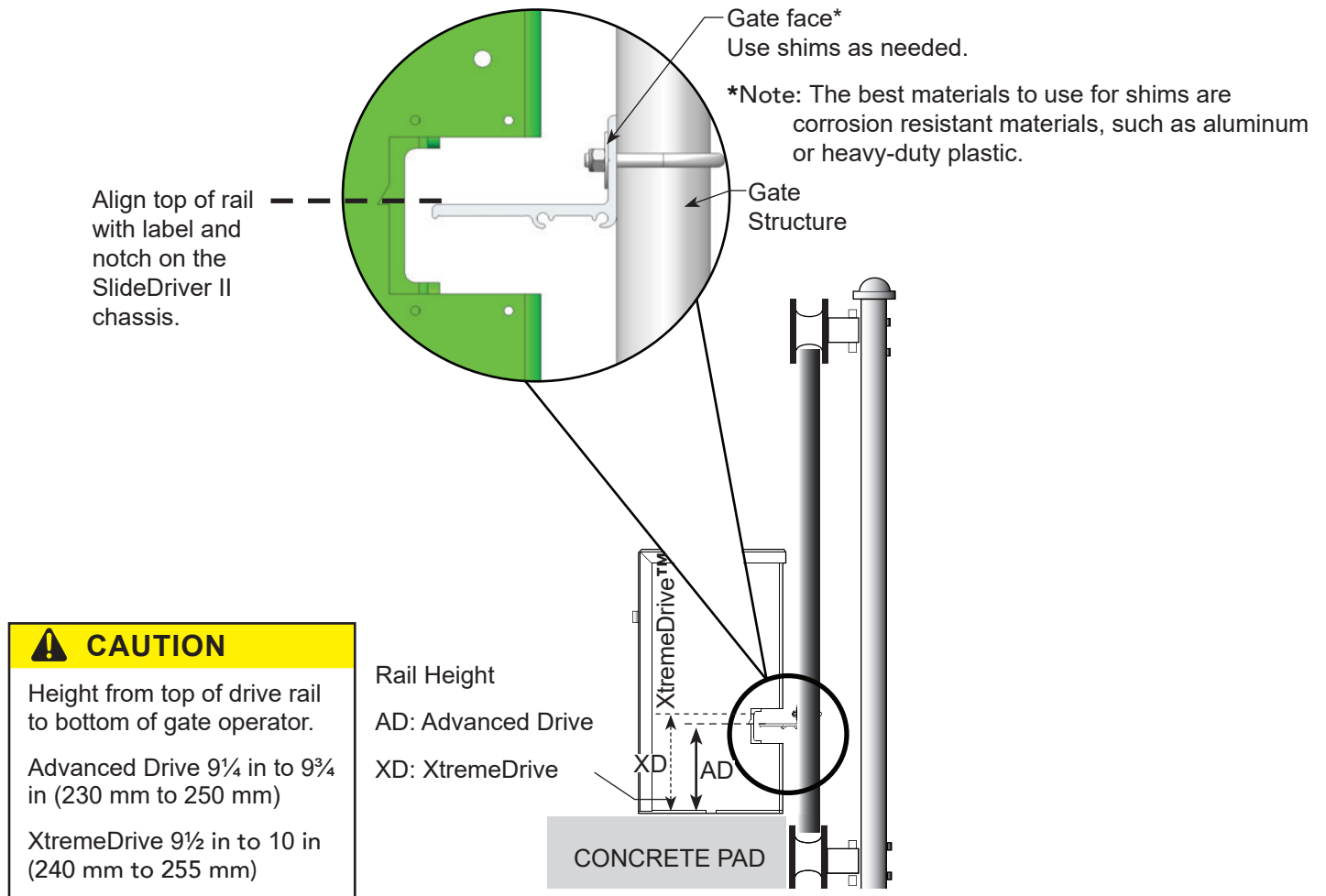

Drive Wheel Spring Tension (Adjustment of Manual Release)

All SlideDriver II operators come equipped with a toggle handle manual release mechanism to disengage the drive wheels from the drive rail.

During shipment, a piece of Styrofoam is placed between the coupling nut and the chassis. If the packaging is still in place, discard it.

WARNING

When releasing the handle inside the chassis, be careful as the mechanism is spring-loaded and drops rapidly. Grasp the toggle handle firmly so your fingers do not get pinched, hit, or crushed.

To disengage the drive wheels, pull the aluminum toggle handle down. As the lower drive wheel drops and disengages from the drive rail, it causes the coupling nut on the threaded rod to drop to its lowest position and push on the base of the operator. This causes the upper drive wheel to lift and disengage from the drive rail.

The coupling nut must be adjusted correctly so the wheels provide a strong clamping force on the drive rail. The red spring should measure 2 in (50 mm) in height when under the correct compression.

Note: If the drive rail is installed at the correct height to the chassis, the toggle release mechanism spreads both wheels equally in relation to the drive rail. If the drive rail has been mounted higher than specified, it may be necessary to use an additional coupling nut and $\frac{3}{8}$ in bolt which can extend beyond the all thread and create additional lift clearance for the upper drive wheel when the toggle handle is released. If this extension method is used, adjust the $\frac{3}{8}$ in bolt so the drive wheels spread equally when they are fully disengaged.

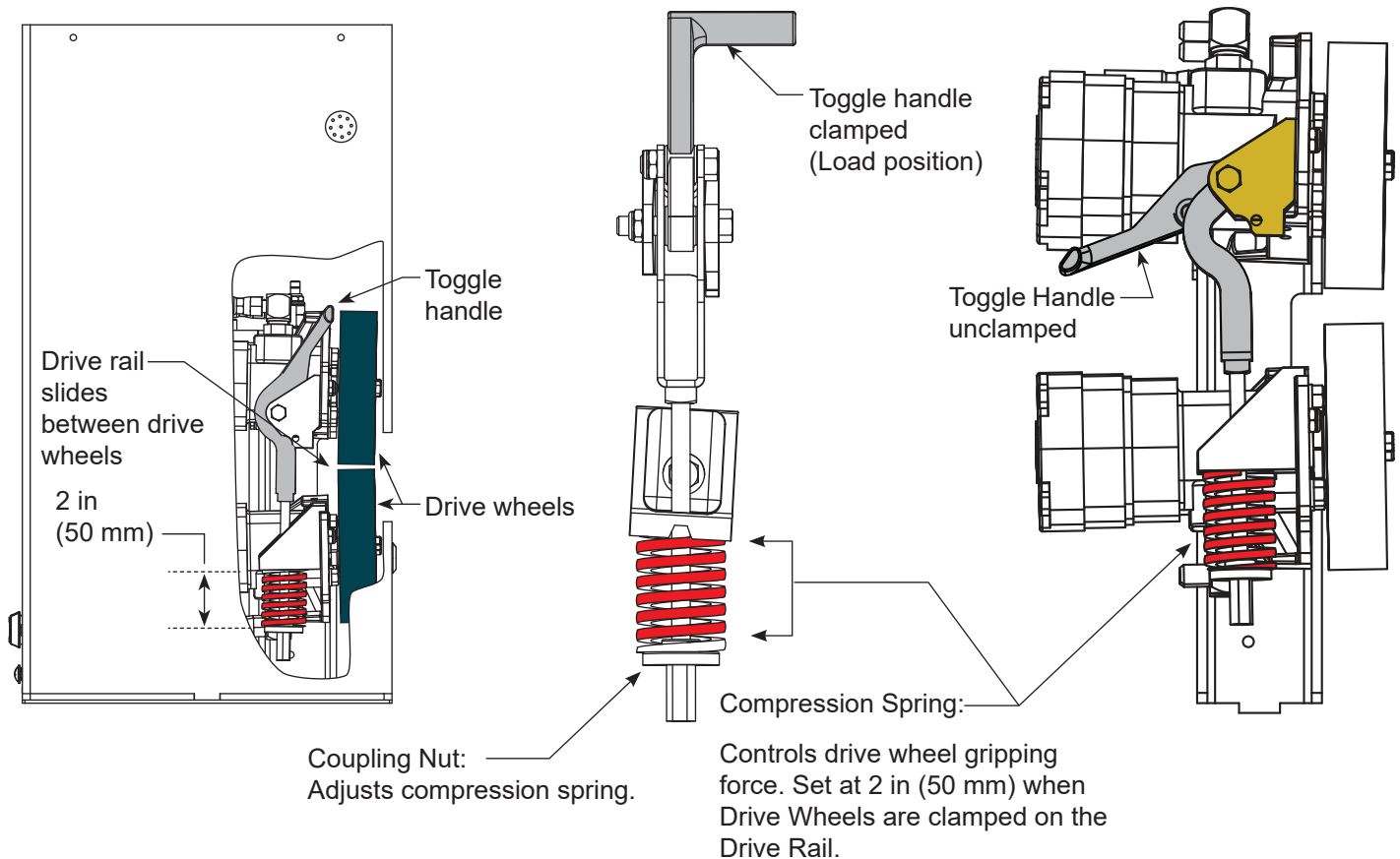

MAINTENANCE

Drive Wheel Assembly

Drive wheel assembly for AdvanceDrive™ and XtremeDrive™ is the same because they use the same wheel hub.

Note: Installation instructions are provided with the replacement drive wheels and are accessible online at support.hysecurity.com.

A quick look at the drive wheel assembly is shown below. Tighten drive wheel mounting bolts to 18 ft-lb.

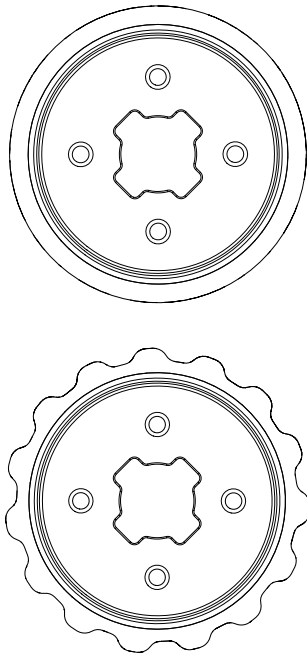

Figure 7. AdvanceDrive and XtremeDrive Wheels

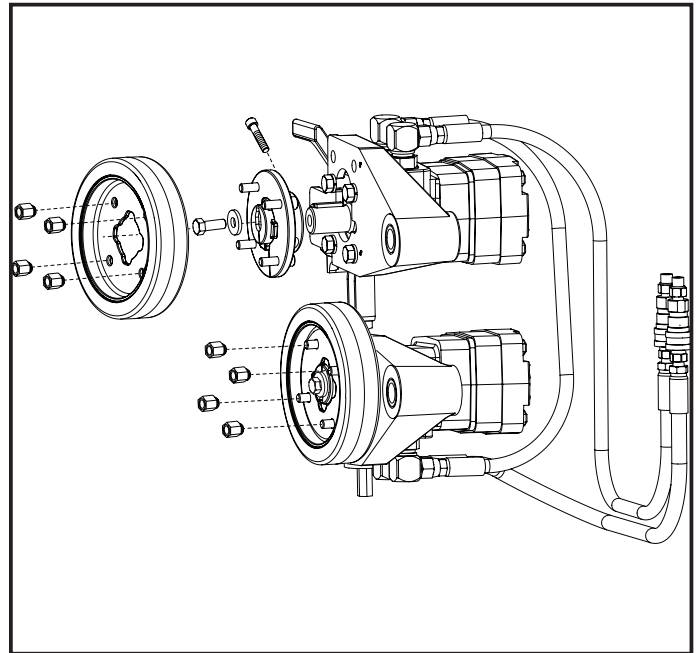

Figure 8. AdvanceDrive Wheels

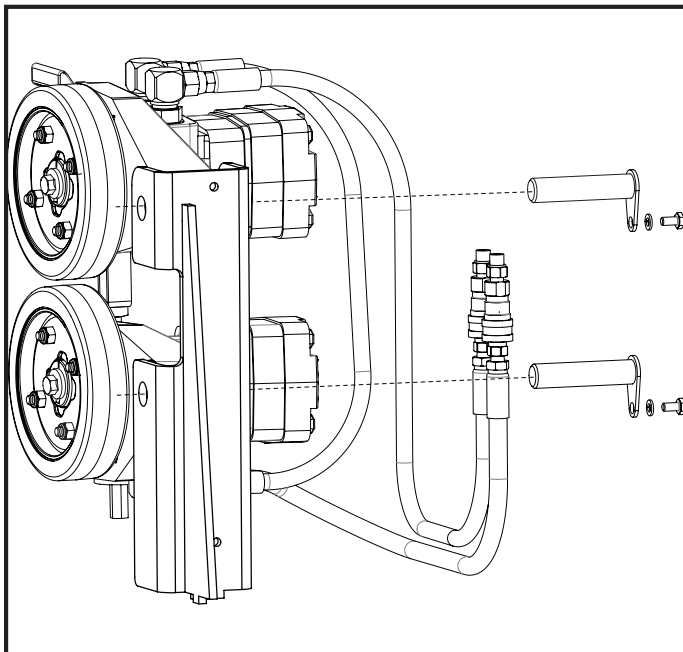

Figure 9. AdvanceDrive Wheels assembled

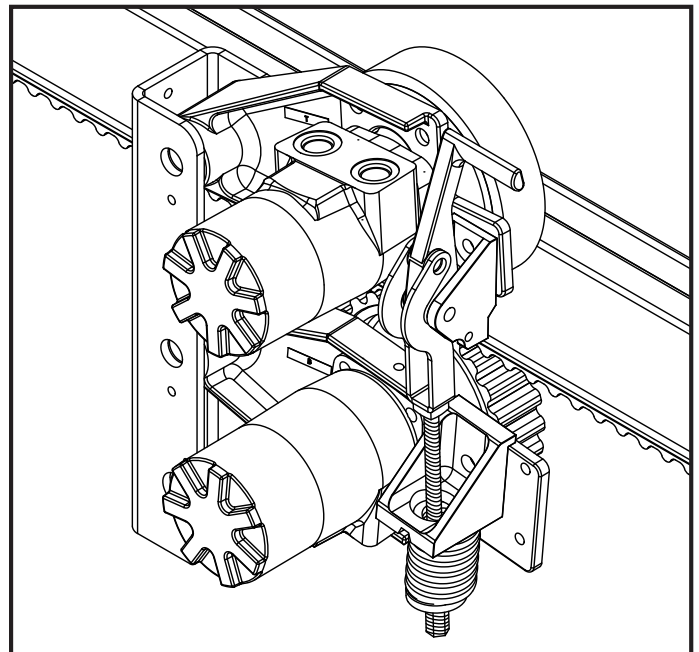

Figure 10. AdvanceDrive and XtremeDrive Wheel combo

HYDRAULIC SYSTEM MAINTENANCE

Fluid Level: Under normal conditions, hydraulic systems do not consume fluid. Check the system thoroughly for leaks, before adding any fluid. If fluid needs to be added:

1. Remove the metal plug from the reservoir.
2. Use HySecurity Uniflow hydraulic fluid; part number MX000970. Gallon sold by our distributors.
3. Fill to within ½ in of the plug level, and then replace plug.

NOTICE

Never use brake fluid. It will severely damage the hydraulic system. Use of any fluid other than fluid recommended by HySecurity may void the operator warranty.

Look for leaks: Occasionally there may be slight seeping at the fittings after some usage. Tightening of the fittings usually corrects the problem. If leaking persists, replace O-rings, fittings or hoses, if required. No further leaks should occur.

To Change Fluid: Unlike a gas engine, the fluid inside a hydraulic system does not foul, so fluid changes do not need to occur often. HySecurity recommends draining the reservoir and replacing the fluid at 24 month intervals. Fluid breakdown caused by heat is the main concern. If the unit is subjected to high use, or you are using the HySecurity biodegradable fluid option (especially in a warm climate), change the fluid more frequently.

To change the hydraulic fluid,

1. Remove the reservoir from the pump pack.
2. Completely empty it.
3. Wipe the reservoir clean and clean the debris screen.
4. Re-assemble the pump unit and refill it with new Uniflow hydraulic fluid.
5. To avoid overfilling, slowly pour the fluid through the filler port near the reservoir's top until the fluid is within one inch of the port's opening.
6. Replace the plug and wipe up any spilled fluid. Spilled fluid dries to a sticky and messy consistency.

Cold Weather Issues:

1. Check that your reservoir is filled with our Uniflow high performance fluid.
2. Excessive ice buildup can partially or totally jam gate operation. Operate the gate manually, while clearing the ice buildup.
3. If the operator is located in an area of extreme snow conditions, regular maintenance to dig the operator out may be required. A heater option is recommended.

Note: A biodegradable fluid option does exist (part number MX002836), but it does not have the same fluid viscosity at extremely low temperatures. Uniflow fluid temperature rating is between -40°F and 158°F (-40°C and 70°C). The biodegradable fluid has a temperature rating between -10°F and 158°F (-23°C and 70°C).

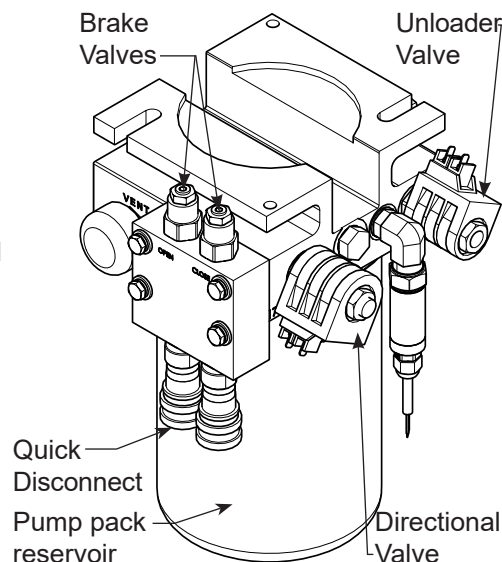

MAINTENANCE

Brake Valves

For SlideDriver II operators with adjustable brake valves proper adjustment of the brake valves is important for smooth operation of the gate (not all SlideDriver II operators have adjustable brake valves). The position and placement of the limit flags on the drive rail plays an important part on how the brake valves work.

Adjustment of the brake valves, one for each direction of travel, will determine how quickly the gate actually stops. If adjustment is needed, loosen the $\frac{9}{16}$ in lock nut on the top of the brake valve and make $\frac{1}{4}$ in incremental turns on the adjustment stem with a $\frac{5}{32}$ in hex key. Loosen to increase braking, tighten to decrease braking. Test cycle the gate after each incremental turn.

Pressure Relief Valve

DO NOT adjust the pressure relief valve. The pressure relief valve governs the maximum system hydraulic pressure. It is located on the backside of the pump. The pressure relief valve is factory set.

Unloader Valve

Only on the SlideDriver II 15 and 40. Allows the motor to start with no hydraulic load.

Directional Valve

The directional valve is solenoid operated and, when energized, directs the hydraulic flow to open the gate. No adjustment of this valve is possible or necessary. The black solenoid coil mounts on its valve stem.

Download the firmware to a USB flash drive:

1. Go to support.hysecurity.com, click on Software, click SmartCNX Code h6.##, and click h.6.##.cnx to download the .cnx firmware file.
2. Connect a USB flash drive to your computer.

Note: FAT32 is the preferred file system for USB flash drives used for SmartTouch 720/725 firmware updates.

3. Navigate to the download folder with the .cnx file.
4. Copy the .cnx file to the root folder of the USB flash drive.
5. Safely disconnect the USB flash drive.

Install the firmware:

6. Move the gate to the open position to allow free flow of traffic. The SmartTouch 720/725 Controller ignores all inputs and outputs during the firmware update.
7. Plug the USB flash drive into the USB port on the SmartTouch 720/725 Controller (Figure 11).
8. Press SELECT when USB OPTIONS MENU appears.
9. Press the UP or DOWN arrow to LOAD SW and press SELECT.
10. Press the UP or DOWN arrow to YES and press SELECT.
11. The display shows LOADING SW while the firmware loads. It could take up to 10 minutes to load the firmware.

NOTICE

Do not shut off power. Do not remove the USB flash drive or disconnect any other cable during firmware update. This can cause SmartTouch 720/725 Controller communication to stop and requires a SmartTouch 720/725 Controller replacement.

12. The display shows COMPLETE and the controller beeps once when firmware loading ends.
13. Remove the USB flash drive.

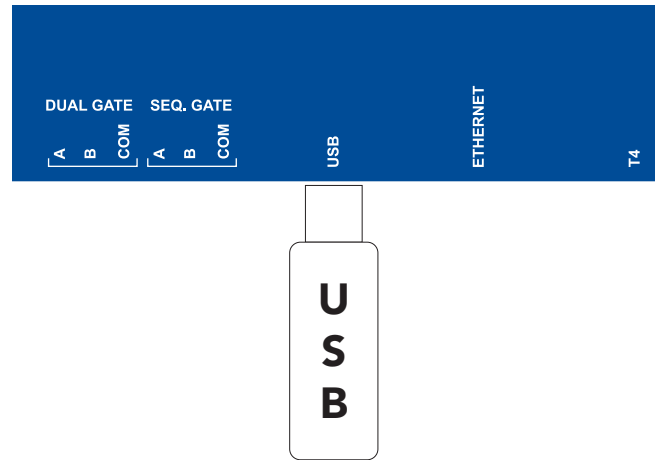
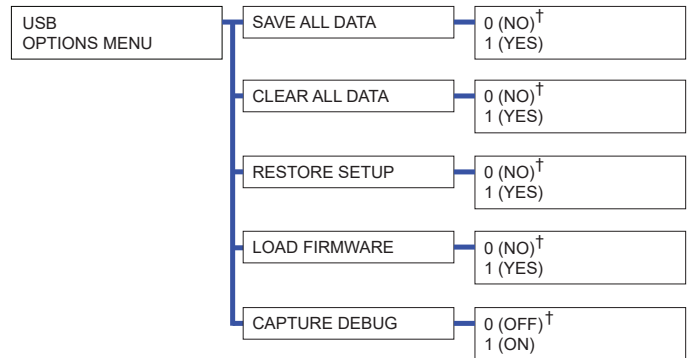

Figure 11. USB Port



SAVE ALL DATA saves the event log data, any stored debug data events, and the menu setup file.

CLEAR ALL DATA clears the event log and any stored debug data.

RESTORE SETUP loads a saved menu setup file onto a new SmartTouch 720/725 controller or operator.

LOAD FIRMWARE loads new firmware after plugging in a USB flash drive with firmware for updates.

CAPTURE DEBUG saves real time debug data onto a USB flash drive until the setting is changed to 0 (OFF). The debug data can be used to determine if there are any intermittent input activations.

TROUBLESHOOTING/ALERTS/FAULTS/ERRORS

Table 1. SmartTouch 720/725 Controller - Troubleshooting

Display Condition	Description Alert, Error or Fault	Possible Causes	Solutions
SAFE MODE	Safe Mode Alert	Occurs when an edge sensor or Inherent Entrapment Sensor (IES) trips. Gate binding, wind, or a faulty edge sensor can cause a false alert. All inputs are still functional during safe mode, but Close Timer is disabled until an operate command is received.	<ol style="list-style-type: none"> 1. Activate any operate command. 2. Remove obstruction. 3. Correct gate hardware. 4. Correct faulty edge sensor. 5. Adjust IES sensitivity.
ENTRAPMENT MODE	Entrapment Mode Alert	<p>Occurs when IES is tripped when gate is already in Safe Mode (two IES trips in one cycle). Operator will not function until it is reset, which can occur by:</p> <ul style="list-style-type: none"> • An Open or Stop command from a push-button control • Pressing STOP button on operator side • Pressing RESET button below display <p>Gate binding, wind, or a faulty edge sensor can cause a false alert. Emergency Close or Fire Open input activation will also stop the gate in Entrapment Mode.</p>	Refer to solutions above.
NO AC POWER	No AC Input Power Advisory only.	AC power is shut off at source (breaker) or is not connected. AC power switch on operator (lower rocker switch) is turned off. Verify relay output from DC Charger is connected to input 8 of the I/O Module when operator is configured for DC power.	<ol style="list-style-type: none"> 1. Reset operator circuit breaker or reset circuit breaker at electrical panel. 2. Verify AC power to battery backup system. Have a licensed electrician check wiring. 3. Verify Power Type Setting is correct.
LOADING FW	Firmware is being loaded into SmartTouch 720/725 Controller.	Firmware is currently being loaded. Display will show which specific processor firmware is loading.	Wait for firmware to finish loading.

TROUBLESHOOTING/ALERTS/FAULTS/ERRORS

Table 1. SmartTouch 720/725 Controller - Troubleshooting

Display Condition	Description Alert, Error or Fault	Possible Causes	Solutions
LOW 24VDC	Low 24VDC UPS Batteries Advisory only.	<p>Occurs when battery voltage has dropped to less than 22V. At this level, batteries have about 20% charge. Normal function until 21V.</p> <ul style="list-style-type: none"> ● No AC Power ● Wiring / Connector problem 	<ol style="list-style-type: none"> 1. Verify AC power. 2. Check all connections. Clean or repair as required. 3. Check battery condition and replace as required. 4. Check charger voltage is 27VDC at red/blue battery wires.
DEAD BATTERY	Extremely low UPS batteries – no automatic operation - batteries below 21V.	<p>Occurs when battery voltage has dropped to less than 21V. At this level, batteries have about 10% charge. Gate will automatically open or close depending upon setting chosen. No additional automatic function is possible, but limited push button control is available down to 18V.</p>	Refer to solutions above.
HYSECURITY BAD POWER	Critically low 24V supply power. This message can occur only on initial start up if power is critically low.	DC power is below 14V – no control functions will be allowed at all.	Refer to solutions above.
No display, LED blinking	<p>SmartTouch 720/725 Controller is in standby.</p> <p>SmartTouch 720/725 Controller is receiving power, but battery voltage is very low.</p>	<p>Several possible causes:</p> <ul style="list-style-type: none"> ● SmartTouch 720/725 controls have been inactive for at least 10 minutes and the display has been disabled. Any button push will turn display back on. ● AC power has been shut off from the operator for too long and the batteries are drained. ● Wiring problem. ● 24V output shorted or drawing too much current. ● Batteries no longer hold a charge. ● Failed SmartTouch 720/725 Controller. ● Disconnected com (HSP) wire between SmartTouch 720/725 controller and I/O Module or VFD. 	<p>Press any button to wake display.</p> <p>Refer to solutions above.</p>

TROUBLESHOOTING/ALERTS/FAULTS/ERRORS

Table 2. SmartTouch 720/725 Controller - Alerts

Display Condition	Description Alert, Error or Fault	Possible Causes	Solutions
ALERT 1 FORCE OPEN	Gate forced open. Alarm will sound.	Gate has been forced off the full close limit and is being prevented from re-closing.	Will self-clear after an open or close input.
ALERT 2 DRIFT CLOSED	Gate drifted closed.	Gate has drifted off the full open limit and is being prevented from re-opening.	Will self-clear after an open or close input.
ALERT 4 MOTOR OVERLOAD	Thermal overload alert. When alert is triggered, gate can only “fully open” until alert is cleared.	For AC operators, the AC motor has a thermal switch that is NC connected to input 8 of the I/O Module or input 1 of the VFD. When this opens the Alert 4 is declared.	Auto clears when thermal switch input closes and a run command is given.
ALERT 5 BOTH LIM ACTIVE	Both limit sensors are on at the same time	<ul style="list-style-type: none"> Limits sensors not connected correctly Failed limit sensor 	<ul style="list-style-type: none"> Repair any wiring issues. Check limit sensors and replace as required.
ALERT 6 LIM NOT RELEASED	The limit did not release when the operator was commanded to move.	<ul style="list-style-type: none"> Wheels are not clamped 3 Phase electric motor may be spinning wrong direction No hydraulic pressure or flow. Failed limit sensor 	<ul style="list-style-type: none"> Ensure wheels are properly clamped to drive rail Check limit sensors and replace as required Verify electric motor is spinning the right direction
ALERT 7 FREQ SHIFT FAULT*	Hy5B detects a frequency change outside normal range.	Likely causes are poor integrity of loops or metallic objects within range.	Check lead-in and roadway loop wires for problems. Replace if necessary.
ALERT 8 LOOP SHORTED*	Hy5B detects a loop shorted to ground.	Caused by inadequate insulation of loop wires.	Refer to solution above.
ALERT 9 LOOP OPEN*	Hy5B detects a lack of continuity in loop wire.	Caused by broken loop wire or wire has come unplugged from detector.	Refer to solution above.
ALERT 10 I2C BUS ERROR*	Communication error detected to a Hy5B vehicle detector.	Caused by removal of Hy5B or lack of integrity of socket connection.	Remove and re-install the Hy5B and press RESET. Replace Hy5B, if necessary.
ALERT 11 DETECTOR FAULT*	A problem detected within an Hy5B vehicle detector.	Caused by a fault within Hy5B.	Remove and re-install the Hy5B and press RESET. Replace Hy5B, if necessary.
ALERT 12 ON TOO LONG*	An input loop (Hy5B or box detector output) is active for more than 5 minutes.	Caused when SmartTouch 720/725 Controller sees an active loop for more than 5 minutes. “Active” loop can be actual or false.	Check traffic patterns at site. Loop and lead in wires should be checked for problems or replaced.

* This message will also indicate which detector the alert applies to: Exit Loop (ELD), Inside Obstruction Loop (IOLD), Outside Obstruction Loop (OOLD), or Center Loop (CLD).

TROUBLESHOOTING/ALERTS/FAULTS/ERRORS

Table 2. SmartTouch 720/725 Controller - Alerts

Display Condition	Description Alert, Error or Fault	Possible Causes	Solutions
ALERT 16 I2C FAILURE		SmartTouch 720/725 has detected an internal communications error. <ul style="list-style-type: none"> • Excessive electrical noise. • Lack of earth grounding. • Internal problem on SmartTouch 720/725. 	<ol style="list-style-type: none"> 1. Determine and remedy source of electrical noise. 2. Install a ground rod. 3. Replace SmartTouch 720/725.
ALERT 17 BAD COIN BATTERY	2 chirps per second every 15 seconds	Small battery on SmartTouch 720/725 is loose or needs replacing.	<ol style="list-style-type: none"> 1. Verify that the battery is properly seated. 2. Replace coin battery. Use a CR2032 coin battery. 3. Restore power. 4. Press RESET button.
ALERT 19 FALSE SLOWDOWN SIGNAL (OT7 ONLY)	2 chirps per second every 15 seconds	Appears only on 50F operators. Slowdown sensor tripped and released (less than 1 second) in middle of run. Check for loose wires, limits and misaligned rails or limit ramps or wrong slowdown switch was tripped, so open slow down in close direction.	Check handing setting and hoses are connected correctly. Verify limit sensor is centered on limit flag in stop position.
ALERT 20 LI BLOCK OPEN		An interlock contact is closed, indicating that the gate latch (lock) is engaged, preventing the operator from starting.	<ol style="list-style-type: none"> 1. Check the interlock terminal and wiring. 2. Verify proper User Relay option is used.
ALERT 21 VFD TRIPPED	2 chirps per second every 15 seconds	Alert indicates the VFD has experienced a hardware or firmware fault. Gate travel will not occur until the alert is cleared. Any open or close command resets the alert and starts the gate moving, unless the VFD is experiencing a fatal error. If you cannot clear the error alert by pressing the open or close button, contact HySecurity.	
ALERT 22 INTLOCK FAILURE	Interlock/Sequential Gate communication lost. Alert auto clears when communication between two operators is restored.	<ul style="list-style-type: none"> • Appears when communication connection is lost for more than 5 seconds between interlocked or sequenced gate operators. • Solo operator has Sequential gate set to ON. 	<ol style="list-style-type: none"> 1. Check cable connections and wiring. Make sure both operators are working properly with compatible firmware versions. 2. Verify Dual Gate and Sequential Gate are both set to (0) on a solo operator.

TROUBLESHOOTING/ALERTS/FAULTS/ERRORS

Table 3. SmartTouch 720/725 Controller - Faults

Display Condition	Description Alert, Error or Fault	Possible Causes	Solutions
FAULT 1 MOTOR RUN TIME	The motor is on longer than the maximum run time selected.	<ul style="list-style-type: none"> • Drive Wheels not clamped properly or Limit Sensor Failed. • May not be enough hydraulic fluid. 	<ol style="list-style-type: none"> 1. Ensure wheels are clamped. 2. Check limit sensors. Replace as required. 3. Increase Max Run Timer.
FAULT 2 SENSOR or INPUT #	Monitored sensor is missing or not working.	<p>This fault can only occur if monitored sensor check fails.</p> <p>Display will show SENSOR 1, SENSOR 2, INPUT 1, INPUT 2, or INPUT 3.</p>	<ol style="list-style-type: none"> 1. Check monitored sensor is connected to SENSOR 1 OR SENSOR 2 COM. 2. Correct malfunctioning monitored sensor.
FAULT 5 LIMIT FAILED (SlideDriver II 50F only)	Stop limit flag not detected after slow down limit flag.	Stop limit flag is not detected within 5 seconds of slowdown limit flag.	<ol style="list-style-type: none"> 1. Verify limits and placement of slow down limit flags. 2. With drive wheels clamped, test Open (GATE OPENING appears on display). Test Close (GATE CLOSING appears on display).
FAULT 6 HYINVERTER OVERLOAD	2 chirps per second once per minute	Excess output load on the AC power supply with HyInverter AC causing power loss.	<ol style="list-style-type: none"> 1. Check gate hardware for binding (ice, poorly maintained gate, etc.). 2. Check start/stop switch on 1 hp motor gate operators.
FAULT 9 PROCESSOR COMMUNICATION	2 chirps per second once per 15 seconds	Failed communication between the main HySecurity microprocessor and the processor that controls BlueBUS and OXI accessories.	<ol style="list-style-type: none"> 1. Cycle power. 2. Replace the SmartTouch 720/725 Controller.

TROUBLESHOOTING/ALERTS/FAULTS/ERRORS

Table 4. SmartTouch 720/725 Controller - Errors

Display Condition	Description Alert, Error or Fault	Possible Causes	Solutions
ERROR 1 DIRECTION ERROR	SmartTouch 720/725 Controller detects operator ran in wrong direction.	<ul style="list-style-type: none"> • Limit sensors wired incorrectly or limit flags installed in wrong location. • Hydraulic Hoses may also be connected to wrong spots. 	<ol style="list-style-type: none"> 1. Check Limit Sensor wires and limit flag alignment. 2. Check Hydraulic hose connections 3. Press RESET to clear fault.
ERROR 2 IES DISCONNECT	Pressure Transducer disconnected or not functional.	<ul style="list-style-type: none"> • The pressure transducer could be bad. • Loose sensor wires. • Check that you have the most current sensor; visit support.hysecurity.com and view the technical bulletins. • Verify the version of the firmware by pressing the Reset button. The firmware version appears on the display. Make a note of it. The firmware version should be h6.## (or later). 	Check to see that the pressure transducer is connected properly.
ERROR 3 Hy5B FAILED*	SmartTouch 720/725 Controller detects communication error with a Hy5B vehicle detector.	Caused by Hy5B removal or socket connection integrity.	<ol style="list-style-type: none"> 1. Press RESET. 2. Remove and re-install Hy5B. 3. Replace Hy5B, if needed.
ERROR 4 PRIMARY- SECONDARY COM	SmartTouch 720/725 Controller detects a communication error between primary and secondary in a dual gate installation.	<p>Several possible causes:</p> <ul style="list-style-type: none"> • Primary/Secondary communication cable is installed incorrectly. • Primary/Secondary not configured properly through Installer Menu. • Operator is not properly earth grounded. • Primary/Secondary communication cable installed in same conduit as high-voltage AC power. • One operator is powered off. • Different firmware versions between operators. Check firmware version currently loaded in operator by pressing RESET. • Dual gate enabled on a solo operator. 	<ol style="list-style-type: none"> 1. Correct communication cable. 2. Verify one operator is set as Primary and the other is set as Secondary. 3. Install ground rod per NEC/NFPA standard. 4. Install communication cables in a low voltage conduit. 5. Ensure AC power is present at both operators and all power switches are On. 6. Make sure both operators are running same firmware version.

* This message will also indicate which detector the alert applies to: Exit Loop (ELD), Inside Obstruction Loop (IOLD), Outside Obstruction Loop (OOLD), or Center Loop (CLD).

TROUBLESHOOTING/ALERTS/FAULTS/ERRORS

Table 4. SmartTouch 720/725 Controller - Errors

Display Condition	Description Alert, Error or Fault	Possible Causes	Solutions
ERROR 5 No display	Display is blank, but the error appears in the log and means that SmartTouch 720/725 Controller detects a serious internal error.	Internal firmware/hardware error. Report any instance of this error to HySecurity Technical Support.	<ol style="list-style-type: none"> 1. Set power switch to OFF and then to ON. 2. Update to latest firmware version. 3. Replace SmartTouch 720/725 Controller.
ERROR 6 DRIVE BOARD COMM	Indicates communication failure between drive module and SmartTouch 720/725 Controller.	Communication with the VFD has failed (OT7 only)	Ensure VFD wiring is attached and VFD/ SmartTouch 720/725 boards are programmed correctly
ERROR 7 MENU CHECKSUM	Firmware issue exists that may require factory reset.	Corrupt firmware or data.	Call HySecurity Technical Support for assistance.
ERROR 10 SLOWDOWN SWITCH (SlideDriver II 50F only)	Slowdown limit failed	The operator tripped the fully Open or Close limit before the Slowdown limit tripped.	Check slow down limit flag alignment with limit sensor.
ERROR 13 HYINVERTER COMMUNICATION	3 chirps per second once per minute	Communication does not exist between the AC power supply with HyInverter AC and the SmartTouch 720/725 controller in the gate operator.	<ol style="list-style-type: none"> 1. Check communication wires are connected and working properly. 2. Verify that your operator has the current firmware. 3. If communication is not desired between HyInverter AC and SmartTouch 720/725 controller, then set Power Type setting to 1 instead of 3.
ERROR 15 I/O MODULE	2 chirps every 15 seconds	Communication is not present between the SmartTouch 720/725 controller and the I/O Module. The I/O Module is standard in the SD15 and SD40, so it should always be present and communicating with the SmartTouch 720/725 controller. For the SD50F, SD80V, and SD200V, check that the programmable inputs and user relays are not set for the I/O Module inputs and outputs if an I/O Module is not used.	<ol style="list-style-type: none"> 1. Check wiring between SmartTouch 720/725 controller and I/O Module. 2. Check that the user relays and programmable inputs are programmed correctly and that an I/O Module is present.

APPENDIX A - FRENCH TRANSLATIONS

FRENCH TRANSLATIONS

The following French translations provided below are found in the Safety Section located at the beginning of the manual.

English	French
IMPORTANT SAFETY INSTRUCTIONS WARNING – To reduce the risk of injury or death:	INSTRUCTIONS DE SÉCURITÉ IMPORTANTES AVERTISSEMENT – Pour réduire les risques de blessures et de mort :
1. READ AND FOLLOW ALL INSTRUCTIONS.	1. LISEZ CETTE NOTICE ET CONFORMEZ-VOUS AUX MISES EN GARDE
2. Never let children operate or play with gate controls. Keep the remote control away from children.	2. Ne laissez jamais les enfants manoeuvrer les commandes de la barrière ou jouer avec celles-ci. Laissez la télécommande hors de la portée des enfants.
3. Always keep people and objects away from the gate. NO ONE SHOULD CROSS THE PATH OF THE MOVING GATE.	3. Tenez toujours à l'écart de la barrière toute personne ou tout objet avoisinant. IL NE FAUT JAMAIS PASSER DANS LA TRAJECTOIRE D'UNE BARRIÈRE EN MOUVEMENT.
4. Test the gate operator monthly. The gate MUST reverse on contact with a rigid object or stop when an object activates the non-contact sensors. After adjusting the force or the limit of travel, retest the gate operator. Failure to adjust and retest the gate operator properly can increase the risk of injury or death.	4. Vérifiez le fonctionnement de l'ouvre-barrière une fois par mois. Le sens de la course DOIT s'inverser lorsque la barrière entre en contact avec un objet dur ou la barrière DOIT s'arrêter lorsqu'un objet active les capteurs sans contact. Vérifiez à nouveau l'ouvre-barrière après tout réglage de la force de déclenchement ou du seuil de fin de course. Un réglage incorrect de l'ouvre-barrière ou l'omission de vérifier à nouveau le fonctionnement de l'ouvre-barrière peut causer des blessures, voire la mort.
5. Use the emergency release only when the gate is not moving.	5. Ne déclenchez le dispositif de désaccouplement d'urgence que lorsque la barrière ne bouge pas.
6. KEEP GATES PROPERLY MAINTAINED. Read the user's manual. Have a qualified service person make repairs to gate hardware.	6. ASSUREZ-VOUS QUE LA BARRIÈRE EST CORRECTEMENT ENTRETENUE. Lisez le manuel de l'utilisateur. Confiez la réparation du matériel de la barrière à un technicien qualifié.
7. The entrance is for vehicles only. Pedestrians must use separate entrance.	7. La voie d'accès est réservée aux véhicules seulement. Les piétons doivent utiliser une voie d'accès différente.
8. SAVE THESE INSTRUCTIONS.	8. CONSERVEZ CES INSTRUCTIONS.
2.3 Install the gate operator only when:	2.3 N'installez l'ouvre-barrière que si :
a. The operator is appropriate for the construction of the gate and the usage Class of the gate,	a. l'ouvre-barrière est approprié pour la structure et la classe d'utilisation de la barrière;

APPENDIX A - FRENCH TRANSLATIONS

English	French
<p>b. All openings of a horizontal slide gate are guarded or screened from the bottom of the gate to a minimum of 1.83 m (6 ft) above the ground to prevent a 57.2 mm (2-1/4 inch) diameter sphere from passing through the openings anywhere in the gate, and in that portion of the adjacent fence that the gate covers in the open position,</p>	<p>toutes les ouvertures de la barrière coulissante sont protégées ou grillagées du bas de la porte jusqu'à un minimum de 1,83 m (6 pi) du sol si bien qu'une sphère de 57,2 mm (2 1/4 po) de diamètre ne peut passer par une ouverture au niveau de la barrière et de la portion de la clôture adjacente que la barrière couvre en position ouverte;</p>
<p>c. All exposed pinch points are eliminated or guarded, and</p>	<p>c. tous les points de pincement sont éliminés ou protégés;</p>
<p>d. Guarding is supplied for exposed rollers.</p>	<p>d. des protections sont fournies pour les galets exposés.</p>
<p>2.4 The operator is intended for installation only on gates used for vehicles. Pedestrians must be supplied with a separate access opening. The pedestrian access opening shall be designed to promote pedestrian usage. Locate the gate such that persons will not come in contact with the vehicular gate during the entire path of travel of the vehicular gate.</p>	<p>2.4 L'ouvre-barrière est destiné à n'être installé que sur des barrières utilisées pour les véhicules. Il faut fournir une autre voie d'accès aux piétons. La voie d'accès pour les piétons doit être conçue pour favoriser le passage des piétons. Placez la barrière de sorte que personne ne puisse entrer en contact avec la barrière pour les véhicules sur l'ensemble de sa trajectoire</p>
<p>2.5 The gate must be installed in a location so that enough clearance is supplied between the gate and adjacent structures when opening and closing to reduce the risk of entrapment. Swinging gates shall not open into public access areas.</p>	<p>c) Pour réduire les risques de coincement lors de l'ouverture et de la fermeture, la barrière doit être installée dans un endroit où la barrière et les structures avoisinantes sont suffisamment éloignées l'une de l'autre. Les barrières battantes ne doivent pas ouvrir dans une zone d'accès public.</p>
<p>2.6 The gate must be properly installed and work freely in both directions prior to the installation of the gate operator. Do not over-tighten the operator clutch or pressure relief valve to compensate for a damaged gate.</p>	<p>2.6 La barrière doit être bien installée et fonctionner librement dans les deux directions avant d'entreprendre l'installation de l'ouvre-barrière. Ne serrez pas trop l'embrayage ou la soupape de surpression de l'ouvre-barrière pour compenser une barrière endommagée.</p>
<p>2.7 Controls intended for user activation must be located at least 1.83 m (6 ft) away from any moving part of the gate and where the user is prevented from reaching over, under, around or through the gate to operate the controls. Exception: Emergency access controls only accessible by authorized personnel (e.g. fire, police, EMS) may be placed at any location in the line-of-sight of the gate.</p>	<p>2.7 Les commandes destinées à l'activation par l'utilisateur doivent être situées à au moins 1,83 m (6 pi) des pièces mobiles de la barrière et à un endroit où l'utilisateur ne peut pas atteindre les commandes par le dessus, par le dessous, par les côtés et au travers de la barrière. Exception : Les commandes d'accès d'urgence accessibles au personnel autorisé seulement (p. ex. pompier, policier, SMU) peuvent être placées à tout endroit dans le champ de visibilité de la barrière.</p>
<p>2.8 The Stop and/or Reset button must be located in the line of-sight of the gate. Activation of the reset control shall not cause the operator to start.</p>	<p>2.8 Le bouton d'arrêt, le bouton de réenclenchement ou ces deux boutons doivent être situés dans le champ de visibilité de la barrière. L'activation des commandes de réenclenchement ne doit pas mettre en marche l'ouvrebarrière.</p>

APPENDIX A - FRENCH TRANSLATIONS

English	French
2.9 A minimum of two (2) WARNING SIGNS shall be installed, in the area of the gate. Each placard is to be visible by persons located on the side of the gate on which the placard is installed.	2.9 Au moins deux panneaux de mise en garde doivent être installés dans la zone de la barrière. Chaque étiquette doit être visible des personnes situées de chaque côté de la barrière sur laquelle l'étiquette est installée.
2.10 For gate operators utilizing a non-contact sensor	2.10 Pour les ouvre-barrières qui fonctionnent avec des capteurs
a. See instructions on the placement of non-contact sensors for each Type of application,	a. Voir les instructions sur le positionnement des capteurs sans contact pour chaque type d'utilisation.
b. Care shall be exercised to reduce the risk of nuisance tripping, such as when a vehicle, trips the sensor while the gate is still moving, and	b. Des précautions doivent être prises pour réduire les risques de déclenchement inutile, comme lorsqu'un véhicule déclenche le capteur alors que la barrière est encore en mouvement.
c. One or more non-contact sensors shall be located where the risk of entrapment or obstruction exists, such as the perimeter reachable by a moving gate or barrier.	c. Un capteur sans contact ou plus doit être situé où il existe un risque de coincement ou d'obstruction, comme dans l'espace que peut occuper la barrière lorsqu'elle est en mouvement.
2.11 For a gate operator utilizing a contact sensor	2.11 Pour les ouvre-barrières qui fonctionnent avec des capteurs
a. One or more contact sensors shall be located where the risk of entrapment or obstruction exists, such as at the leading edge, trailing edge, and postmounted both inside and outside of a vehicular horizontal slide gate.	a. Au moins un capteur de contact doit être situé où il existe un risque de coincement ou d'obstruction, comme sur le bord d'ouverture, sur le bord de fermeture et sur les poteaux montés sur l'intérieur ou l'extérieur d'une barrière coulissante pour véhicules.
b. A hardwired contact sensor shall be located and its wiring arranged so that the communication between the sensor and the gate operator is not subjected to mechanical damage.	b. Un capteur de contact doit être installé et câblé de sorte à éviter que la communication entre le capteur et l'ouvrebarrière soit gênée par des dommages mécaniques.
c. A wireless device such as one that transmits radio frequency (RF) signals to the gate operator for entrapment protection functions shall be located where the transmission of the signals are not obstructed or impeded by building structures, natural landscaping or similar obstruction. A wireless device shall function under the intended end-use conditions.	c. Un dispositif sans fil, comme un appareil qui transmet des signaux de radiofréquence (RF) à l'ouvre-barrière pour prévenir le coincement, doit être situé à un endroit où la transmission des signaux ne sera pas obstruée ou gênée par des structures, des arbres ou d'autres obstacles similaires. Un dispositif sans fil doit fonctionner selon les conditions d'utilisation finale prévues.
d. One or more contact sensors shall be located on the inside and outside leading edge of a swing gate. Additionally, if the bottom edge of a swing gate is greater than 152 mm (6 inches) but less than 406 mm (16 inches) above the ground at any point in its arc of travel, one or more contact sensors shall be located on the bottom edge.	d. Au moins un capteur de contact doit être situé sur les bords d'ouverture intérieur et extérieur d'une barrière battante. De plus, si le dessous d'une barrière battante est situé à plus de 152 mm (6 po) mais à moins de 406 mm (16 po) du sol à l'un des points de sa trajectoire, au moins un capteur de contact doit être situé sur le bord inférieur.

WARRANTY

1. Warranty.

HySecurity Gate, Inc. ("HySecurity") warrants that at the time of sale each HySecurity-branded product that it sells will, in all material respects, conform to its then applicable specification and will be free from defects in material and manufacture.

The following additional durational warranties apply to HySecurity products, depending on whether (1) the product is purchased through an authorized HySecurity distributor and (2) whether a timely and complete product registration is submitted to HySecurity.

It is therefore important that you register your product with HySecurity, online at www.hysecurity.com/warranty, within the 60-day period described below.

1(a) HySecurity Products Purchased Through Authorized Distributors and Properly Registered

For any gate operator product that is purchased from an authorized HySecurity distributor (this excludes product purchased through internet resellers or any distributor not authorized by HySecurity), if the product registration is completed by the Dealer/Installer or End User within 60 days of the date of purchase, the following warranty terms will apply. HySecurity warrants that the product will remain serviceable for the following periods:

- a) Hydraulic industrial gate operator hydraulics, controls, and mechanical components: Five Years or 500,000 gate cycles (whichever occurs first) after the date of installation,
 - b) Hydraulic wedge operator hydraulics and controls: Five Years or 500,000 cycles (whichever occurs first) after the date of installation. Wedge mechanical components: Two Years after the date of installation,
 - c) Electromechanical pad-mounted Slide and Swing operators: Five Years or 500,000 cycles (whichever occurs first) after the date of installation, except single family residential usage, where the warranty term shall be Seven Years after the date the product was shipped from HySecurity,
 - d) Electromechanical linear actuator Swing operators: Two Years after the date of installation,
 - e) Electromechanical surface mount wedge operator electronics: Two Years or 500,000 gate cycles (whichever occurs first), after the date of installation,
 - f) Electromechanical Barrier Arm Operators: Two years or 1,000,000 gate cycles (whichever occurs first) after the date of installation,
- provided that* the preceding Five Year warranty period in (a), (b), and (c) will not extend beyond seven years from the date that the product was shipped from HySecurity, and the Two Year warranty period in (b), (d), (e), and (f) will not extend beyond four years from the date that the product was shipped from HySecurity.

The preceding warranty durations do not apply to the products or components described below (g-j), which have a shorter warranty period:

- g) Hydraulic gate operator drive wheels, including XtremeDrive™ wheels and rack: Two Years from date of installation.
- h) AC and DC power supplies, chargers, and inverters and HyNet™ Gateway: Two Years from date of installation, except batteries.
- i) Batteries: One Year from date of shipment from HySecurity.
- j) Components subject to normal wear including, but not limited to, chains, belts, idler wheels, sprockets and fuses: One Year from date of installation.

1(b) HySecurity Products Not Purchased Through an Authorized Distributor or Not Properly Registered within 60 Days

For any product that is not purchased from an authorized HySecurity distributor or for which the product registration was not completed by the Dealer/Installer/End User within sixty (60) days of the date of purchase, the following warranty will apply: HySecurity warrants that the product will remain serviceable for the following periods, which begin on the date that the product was shipped from HySecurity:

- a) All gate operators: One Year or 100,000 gate cycles, whichever comes first.
- b) AC and DC power supplies, chargers, or inverters: One Year.
- c) HyNet™ Gateway: One Year.
- d) Hydraulic gate operator drive wheels: One Year.

1(c) Replacement Parts

HySecurity warrants that replacement parts (whether new or reconditioned) will remain serviceable for One Year from the date that the part was shipped from HySecurity or the remaining period of the Gate Operator warranty, whichever is longer.

1(d) Limitations and Exclusions Applicable to Each of the Preceding Warranties.

The preceding warranties shall not apply to equipment that has been (1) installed, maintained, or used improperly or contrary to instructions; (2) subjected to negligence, accident, vandalism, or damaged by severe weather, wind, flood, fire,

terrorism or war; or (3) damaged through improper operation, maintenance, storage or abnormal or extraordinary use or abuse. Any modification made to products will void the warranty unless the modifications are approved in writing by HySecurity in advance of the change (this exclusion does not apply to normal installation of approved accessories and/or protective devices or sensors). It is the responsibility of the Distributor, Dealer/Installer, or End User to ensure that the software version in the product is maintained to the latest revision level.

The preceding warranties do not extend to accessories when those items carry another manufacturer's name plate and they are not a part of the base model. HySecurity disclaims all warranties for such accessory components, which carry only the original warranty, if any, of their original manufacturer. HySecurity hereby assigns its rights under such manufacturer warranties—to the extent that such rights are assignable—to Buyer.

These warranties extend to HySecurity's Distributors, to the Dealer/Installer, and to the first End User of the product following installation. They do not extend to subsequent purchasers.

2. Exclusion of Other Warranties.

The warranties contained in Section 1 are the exclusive warranties given by HySecurity and supersede any prior, contrary or additional representations, whether oral or written. Any prior or extrinsic representations or agreements are discharged or nullified. HYSECURITY HEREBY DISCLAIMS AND EXCLUDES ALL OTHER WARRANTIES—WHETHER EXPRESS, IMPLIED, OR STATUTORY—INCLUDING ANY WARRANTY OF MERCHANTABILITY, ANY WARRANTY OF FITNESS FOR A PARTICULAR PURPOSE, ANY LIABILITY FOR INFRINGEMENT, AND ANY WARRANTIES OTHERWISE ARISING FROM COURSE OF DEALING, COURSE OF PERFORMANCE, OR USAGE OF TRADE.

3. Buyer's Exclusive Remedies for Any Nonconformity.

If a HySecurity product fails to conform to the warranties in Section 1, Buyer must notify and order replacement parts from the Distributor through which the product was purchased within a reasonable time and in no event more than thirty (30) days after the discovery of the nonconformity. HySecurity will investigate and, in the event of a breach, will provide, within a reasonable period of time, one of the following: (1) repair or replacement of any nonconforming products or components or (2) refund of the price upon return of the nonconforming items. HySecurity reserves the right to supply used or reconditioned material for all warranty claims. HySecurity will not be considered to be in breach of or default under this Warranty because of any failure to perform due to conditions beyond its reasonable control, including any force majeure. This warranty does not cover any incidental expenses, including fines or penalties, temporary security, labor, shipping, travel time or standby time that are incurred for inspection or replacement of any nonconforming items. As a condition of warranty coverage, warranty claims must be submitted in accordance with the procedures described on the HySecurity form, "RMA Procedures."

THE REMEDY SELECTED BY HYSECURITY IN ACCORDANCE WITH THIS PARAGRAPH SHALL BE THE EXCLUSIVE AND SOLE REMEDY OF BUYER FOR ANY BREACH OF WARRANTY.

4. Exclusion of Consequential and Incidental Damages.

HYSECURITY SHALL NOT BE LIABLE FOR ANY INCIDENTAL, SPECIAL, OR CONSEQUENTIAL DAMAGES, WHETHER RESULTING FROM NONDELIVERY OR FROM THE USE, MISUSE, OR INABILITY TO USE THE PRODUCT OR FROM DEFECTS IN THE PRODUCT OR FROM HYSECURITY'S OWN NEGLIGENCE. This exclusion applies regardless of whether such damages are sought for breach of warranty, breach of contract, negligence, or strict liability. This exclusion does not apply to claims for bodily injury or death.

5. Severability.

If any provision of this warranty is found to be invalid or unenforceable, then the remainder shall have full force and effect.

6. Proprietary Rights.

HySecurity retains and reserves all right, title, and interest in the intellectual property rights of its products, including any accompanying proprietary software. No ownership of any intellectual property rights in the products or accompanying software is transferred to Distributor, Dealer/Installer, or End User.

7. Applicable Law.

This warranty will be interpreted, construed, and enforced in all respects in accordance with the laws of the State of Washington, without reference to its choice of law principles. The U.N. Convention on Contracts for the International Sale of Goods will not apply to this warranty.

powered by
SmartTouch 725

Technical Specifications

Model	SlideDriver II SD15	SlideDriver II SD40	SlideDriver II SD50F	SlideDriver II SD80V	SlideDriver II SD200V
Duty Cycle	Continuous				
Horsepower	1 hp	1 hp; DC Option 2 hp	2 hp		5 hp; DC Option 4 hp
Drive	Hydraulic		Hydraulic with VFD motor control		
Drive Wheels	Two 6 inch (15 cm) AdvanceDrive wheels		Two 8 inch (20 cm) AdvanceDrive wheels	One 8 inch (20 cm) AdvanceDrive wheel, One 8 inch XtremeDrive wheel and 27 ft (8 m) of rack	Two 8 inch (20 cm) AdvanceDrive wheels, Two 8 inch XtremeDrive wheels and 52 ft (16 m) of rack
Rate of Travel	1 ft/s (30 cm/s)		Field adjustable, 2.2 ft/s (70 cm/s) or 3 ft/s (91 cm/s). Emergency Fast Operate 3 ft/s (91 cm/s)	Field adjustable, .75 ft/s (23 cm/s) or 1 ft/s (30 cm/s).	
Gate Length Max.	Limited only by weight				
Gate Weight Max.	Up to 1,500 lb (680 kg)	Up to 4,000 lb (1,814 kg)	Up to 5,000 lb (2,268 kg)	Up to 8,000 lb (3,629 kg)	Up to 20,000 lb (9,072 kg)
Pull Force	300 lb (136 kg)			600 lb (272 kg)	1,200 lb (544 kg)
UPS Battery Backup Cycles*	Optional 230V AC Power Supply w/HyInverter AC™	Select option SB-2-2J for DC configuration. Requires DC Power Supply DCPS-60, purchased separately.	Optional 230V AC Power Supply w/HyInverter AC™		Select option SB-2-2T for DC configuration. Requires DC Power Supply DCPS-150 ordered separately.**
Temperature Rating	-40° to 158° F (-40° to 70° C)				
Single Phase Voltages	115/208-230V 60 Hz, 110/220V 50 Hz***		208-230V 60Hz,220V 50Hz***		N/A
Three Phase Voltages	208-230/460V 60Hz,220/380/440V 50Hz***				
Included Accessories	One premium EMX IRB-MON photo eye, one 5-foot premium ASO edge sensor				N/A
Communication	BlueBUS, USB, Ethernet, RS-485, Bluetooth, OXI receiver				
User Controls	SmartTouch 725 Controller with 70+ configurable settings. 32 character OLED display and 7 tactile buttons, or Bluetooth smartphone interface, for programming. SmartTouch 720 Available without Bluetooth or Ethernet.				
Relays	8 Configurable relays: Two 250V 20A electromechanical relays and six 30VDC 2A solid state relays		Three configurable user relays: Two 30VDC 2A solid state, one 240VAC, 20A electromechanical. Optional I/O Expansion module for 8 additional relay outputs.		
Enclosure	N/A				
Finish	Zinc plated with powder coating				
ETL Listed (UL 325)	Usage Class I, II, III, IV		Usage Class III, IV		
Warranty	5 year w/product registration				

*The actual number of gate cycles available from battery power depends upon gate resistance to travel, cycle length, battery size, state of charge and health, ambient temperature, accessory power draw and frequency of gate cycles during power outage.

**SlideDriver II SD200 UPS has a 2,000 ft/hr (610 m/hr) expected duty cycle. Actual duty cycle depends on site specific conditions and gate configuration.

***Refer to Installed Options on pricing for all 50Hz voltages, which are special order.



Contact Information:

Visit support.hysecurity.com for Installation manuals, replacement part instructions, part diagrams and more.

Qualified Nice | HySecurity distributors are experienced and trained to assist in resolving installation problems. For the name of a qualified distributor near you, call HySecurity at 800-321-9947. *Before contacting your distributor or HySecurity Technical Support, obtain the serial number of your operator.

Part	Version
System firmware	h6.06
SmartTouch 720/725	RevA, RevC

Note: If the versions above do not match your operator visit the website in Contact Information below for a manual that matches your operator.

SLIDEDRIVER II INSTALLER CHECKLIST

This checklist is provided by HySecurity and is to be used after installing a SlideDriver II gate operator.

1. Read, understand, and follow the Safety Requirements section (page 3 - page 11) of this document throughout the commissioning and installation process.
2. Before checking the items in this list, make sure power is turned OFF at the main power disconnect and the operator's control box power switch is also in the OFF position.
3. Lower the toggle handle to unclamp the drive wheels from the drive rail and check the following:

- Gate moves smoothly and freely by hand.
- WARNING placards mounted on both sides of the gate within sight of vehicle and pedestrian traffic per UL 325 requirements.
- Electric motor wired properly.
- Incoming power supply voltage matches the label on the motor and control box.
- Gate operator is level.
- Operator is labeled as appropriate for both the type and UL usage class of the gate.

Make sure Ø, hertz, and power match the operator and its labeling:

- 1 Ø 3 Ø 50 Hz 60 Hz
- DC-24V 115 VAC 208 VAC 230 VAC 480 VAC ___V

- Power cable run to the operator is of sufficient wire size to handle starting current.
 - NEC/NFPA ground rod is installed.
 - All wires and cables are clear of moving parts (limits, valves, power, etc.).
 - Breather cap has been installed, replacing the Vent Plug in the pump.
 - Oil level checked.
 - All chassis and base riser bolts are tight.
 - Gate wheels & rollers have covers.
 - Pinch points protected.
 - Permanently mounted controls intended for user activation must be located at least 6 ft (1.83 m) away from any moving part of the gate and where the user is prevented from reaching over, under, around or through the gate to operate the controls.
 - Pedestrian gate exists.
 - Physical gate stops are present.
 - On gate, protective mesh complies with ASTM F2200 and UL 325 standards.
 - Gate is not on a slope.
4. For the remaining checks, you want to cycle test the gate operator. To do so,
 - Temporarily, disconnect any peripheral devices except external entrapment sensors.
 - Re-engage the wheels by lifting the toggle handle and clamping the drive wheels onto the drive rail.
 - Turn the main power ON, and then turn ON the power switch located on the operator's control box.

SLIDEDRIVER II INSTALLER CHECKLIST

5. Prior to moving the gate, make sure the wheel clamp spring is compressed to 2 in (50 mm).
6. Cycle test the gate by pressing the CLOSE and OPEN buttons. Allow the gate to continue traveling throughout its entire range while you or your assistant checks the following:
 - Gate handing is set correctly. See product literature for information on gate handing.
 - Horizontal rail surface is: Advanced Drive 9¼ in to 9¾ in (230 mm to 250 mm) or XtremeDrive 9½ in to 10 in (240 mm to 255 mm) above the pad over full gate travel.
 - Rail flange, attached to the gate supports, remains at a distance of 1¾ in ± ⅛ in (40 mm ± 3 mm) from the outside edge of the operator (edge closest to the gate panel) over the full range of gate travel.
 - Drive wheel face(s) are parallel to the rail ± ⅛ in (3 mm) with a 24 in (610 mm) straight edge.
 - The Dual Limit Sensor is adjusted to clear the drive rail while centered over the Limit Flags.
 - Limit Flags are adjusted to stop the gate at least 2 in (50 mm) from the end of travel.
7. External entrapment protection sensors, accessories, and options have been installed tested and comply with UL 325 Standard of Safety.

8. Check all those that apply:

- | | | | |
|---|--|---|--|
| <input type="checkbox"/> Free exit | <input type="checkbox"/> Inside Obstruction Loop | <input type="checkbox"/> Outside Obstruction Loop | |
| <input type="checkbox"/> Open edge | <input type="checkbox"/> Close edge | <input type="checkbox"/> Open photo eye | <input type="checkbox"/> Close photo eye |
| <input type="checkbox"/> Stop input (1) | <input type="checkbox"/> Local Open (2) | <input type="checkbox"/> Close timer set (3) | <input type="checkbox"/> Radio open (4) |
| <input type="checkbox"/> IES sensor | <input type="checkbox"/> Fire Dept. Open | <input type="checkbox"/> Emergency Close | <input type="checkbox"/> Solenoid lock |

Other accessories and important settings: _____

9. Safety sensors and other I/O programmed properly.

Date: _____

Operator Serial Number: _____

Installer Name and contact (please print): _____

End user's name and contact (please print): _____

Site address: _____

Notes: _____



Nice North America | HySecurity
Gate & Barrier Division
6705 S 209th St, Ste 101
Kent, WA 98032

[hysecurity.com](https://www.hysecurity.com)

MX5385-01 REV-C 09-01-2023 | PN: 901227145