

Tools required:

- Phillips-head screwdriver
- Standard hex key set
- Standard box end wrench set
- Standard socket wrench set (with ½-inch extension)
- Torque wrench
- Hammer & punch
- T-handle 3/16 -inch hex key
- Emery cloth

Optional:

- Wheel puller (to remove existing wheels)
- Anti-seize lubricant

Site Planning & Install Tips:

- At retrofit sites, you will need to remove the existing drive wheel assembly.
- Torque specifications must be adhered to or you will void the Limited Warranty.

Torque Specifications:

Tighten to 25 ft-lb:

- ⅝ - 24 Nylock nuts (drive wheel)
- ⅝ - 24 x 1-inch socket head cap screw (clamping screw)

Tighten 30 to 40 ft-lb:

- Hex head bolt that secures the drive wheel to the motor shaft.

AdvanceDrive™ Wheel System

1 Open the SlideDriver™ and Position Gate.

NOTE: *Unlock the cover, if necessary.*

1. Loosen the two Phillips-head screws at the base of the cover.
2. Lift the cover off the gate operator and set it aside.
3. Determine if the gate needs to be open for vehicular traffic while you're changing out the drive wheels. If it does, press the Open button to open the gate.



CAUTION

Turn OFF power to the SlideDriver and take the necessary precautions to avoid electrical shock.

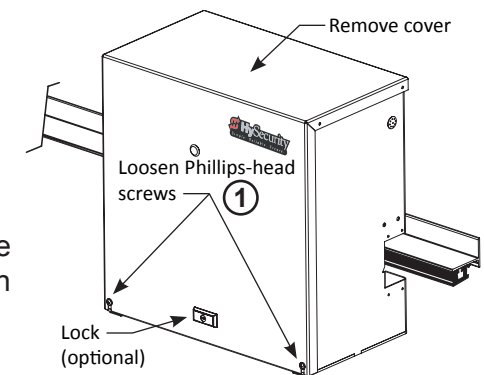

2 Turn OFF power at the Control Box.



CAUTION

Take the necessary precautions when releasing the toggle handle inside the chassis. Be careful as the mechanism is spring-loaded and drops rapidly. Do NOT grip the toggle handle! Keep your fingers above the handle. The spring produces a force of about 1800 psi onto the drive wheels. Slight downward pressure on the toggle handle causes the handle to drop rapidly. Keep your fingers, hands and tools clear of the area when the toggle handle deploys.

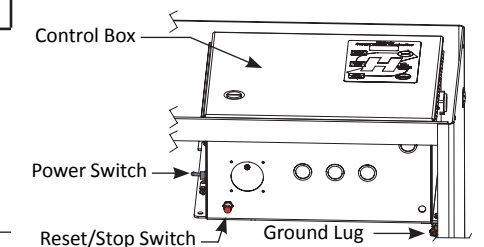

3 Release the Drive Wheels and disconnect the Hydraulic Hoses.

1. Remove the hydraulic hoses from the pump pack.
NOTE: *Have rags handy. Hydraulic fluid may drip from the hoses.*
2. Release the drive wheels by carefully lowering the Toggle Handle. Read the CAUTION note.

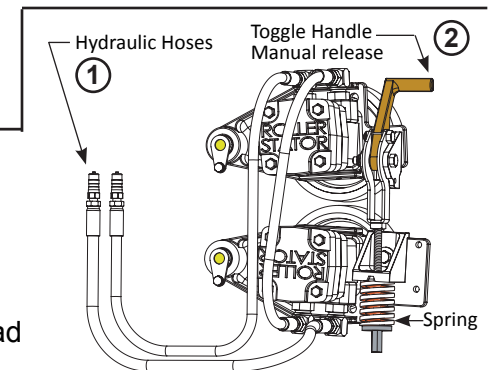

4 Remove the Drive Arm Motor Mount Assembly brackets.

- Using a 7/16-inch box end wrench, loosen and remove the two bolts and washers that secure the pivot pins to the chassis bracket.

NOTE: It is easier to remove the upper drive arm motor mount first.

- Turn the tabs on the pivot pins so they can be used as a handle.
- Slide the pivot pins out of the chassis bracket while supporting the drive arm motor mount assembly. Place the entire assembly on a level workspace.

NOTE: Two access holes exist on the backside of the SlideDriver. You can use a punch and hammer if you need to break loose the pivot pins to slide the drive wheel assembly out.

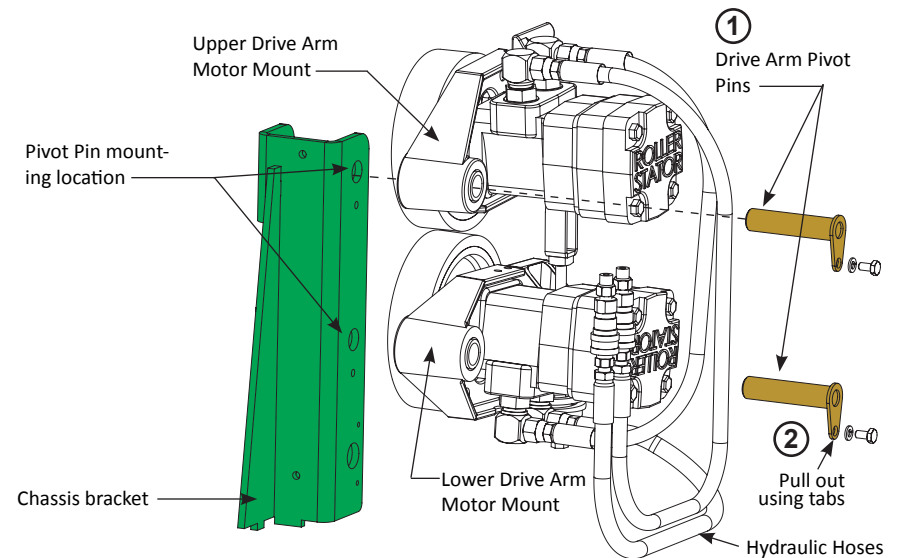

Drive Arm Motor Mounts and Chassis

5 Remove the Drive Wheels from the Motor Shaft

NOTE: Repeat for each drive wheel.

- Remove the hex bolt and washer, and discard.
- Remove the clamping screw from the side of the wheel hub, then remove the wheel hub from the motor shaft.

NOTE: A wheel puller or other mechanical means may be required to slide the wheels off the motor shafts.

- Remove the motor shaft keys from each motor shaft. Discard the shaft keys.
- Clean any debris from the motor shafts (an emery cloth works well).

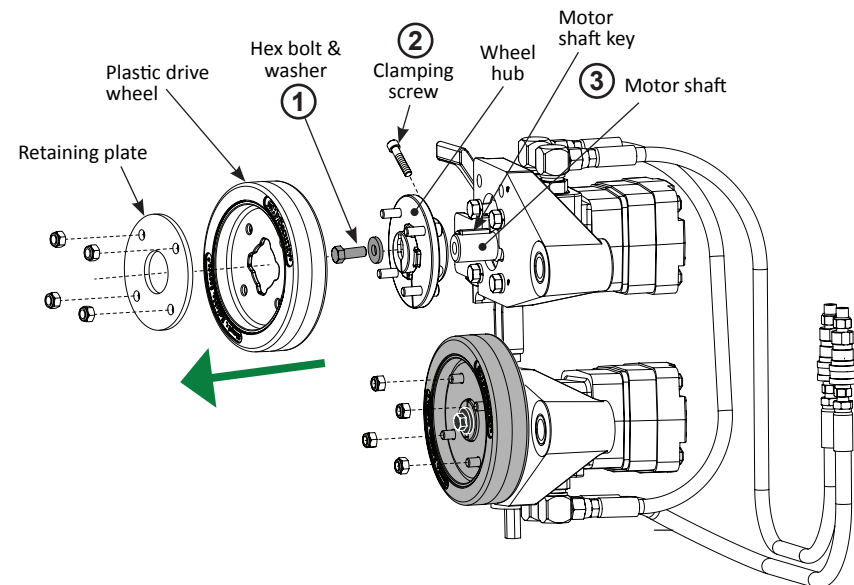

Drive Wheels and Motor Shafts

continued...

6 Separate old AdvanceDrive Wheels from wheel hub.

NOTE: Repeat steps 6 and 7 for each drive wheel.

1. Unscrew the four nuts from the retaining plate.
2. Remove plate and wheel from the wheel hub and discard.
3. Locate the motor shaft key in the AdvanceDrive wheel kit and insert it onto the motor shaft. Refer to illustration on page 2 (5, Step 3).

7 Install the new AdvanceDrive Wheels.

1. Position the wheel hub in line with the motor shaft so the bolt heads on the wheel hub face the Drive Arm Motor Mounts.
2. Align the key cutout and slide the wheel hub onto the motor shaft.
3. Locate the hex head bolt and washer in the AdvanceDrive wheel kit. Place the washer on the bolt.
4. Insert the bolt through the wheel hub and into the motor shaft. Tighten the bolt using a **torque wrench set at 30 to 40 ft-lbs.**
5. Place a drop of Loctite onto the threads of the clamping screw and reinsert it. **Tighten to 25 ft-lbs.**
6. Install the AdvanceDrive wheel onto the four mounting bolts.
7. Use a 1/2-inch wrench or socket to nominally tighten the four lock nuts onto the four mounting bolts on the wheel hub.
8. After nominal tightening, use a **torque wrench set to 25 ft-lbs** to fully tighten the four lock nuts.



CAUTION

Use a torque wrench set to 25 ft-lbs to tighten the drive wheel fasteners (4 lock nuts and 1 clamping screw). Twenty-five foot pounds is comparable to a 1/2 of a turn past snug. A torque wrench is the recommended tool. Use a torque wrench set between 30 and 40 ft-lbs to tighten the hex head bolt that secures the wheel hub to the motor mount. If the fasteners are not torqued properly, you will void the Limited Warranty.

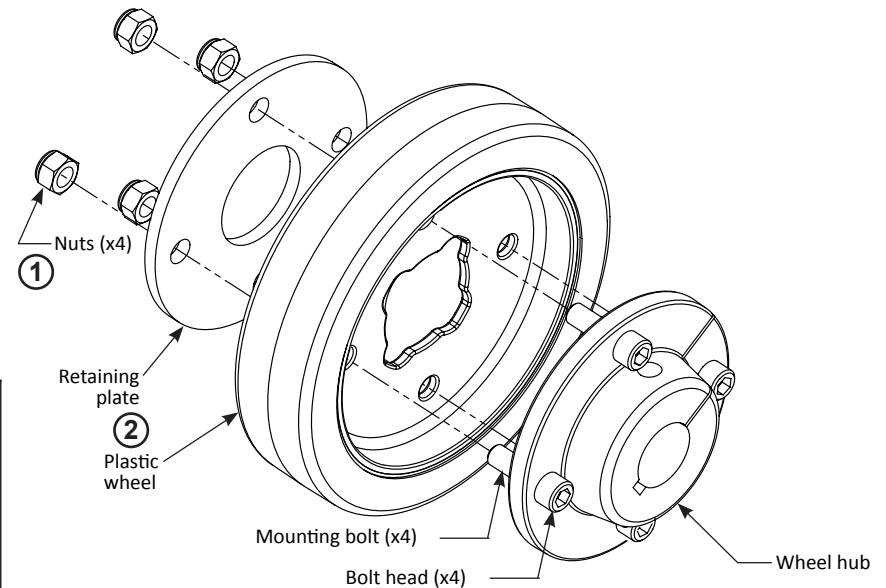

Old AdvanceDrive Wheel Assembly / Wheel Hub

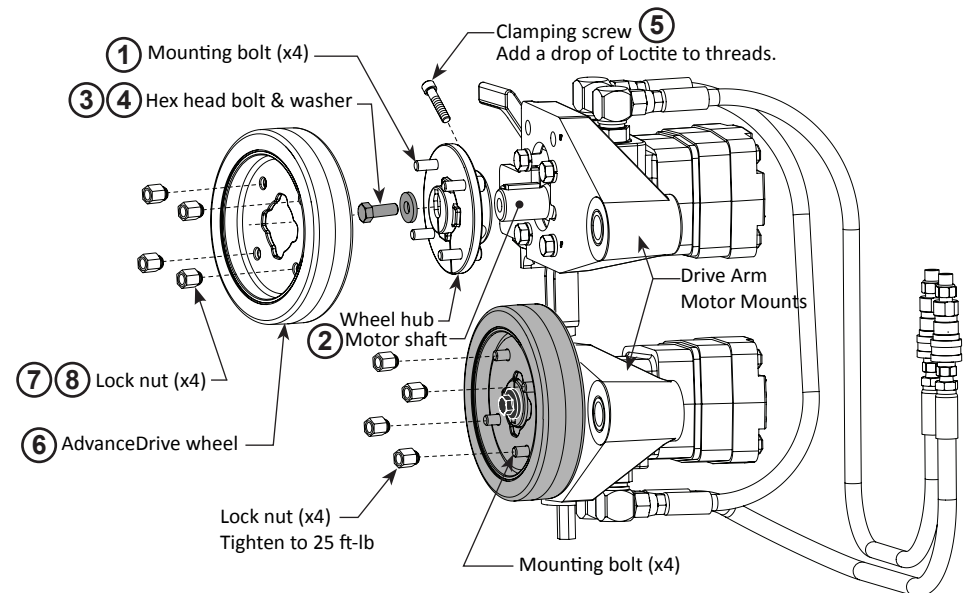

New AdvanceDrive Wheel Assembly / Wheel Hub

8 Reinstall the Drive Arm Motor Mounts onto the Chassis.

NOTE: Install the lower drive arm motor mount onto the chassis first.

1. Slide the Drive Arm Pivot Pins through the motor mounts and into the chassis bracket.
2. Turn the tabs down along the chassis and replace the washers and bolts removed in step 4.1.



CAUTION

When the drive arm motor mounts and AdvanceDrive Wheels are secured to the chassis, measure the compression spring at the base of the Toggle Handle. It's required length is 2-inches after the AdvanceDrive Wheels have been clamped onto the drive rail. To tension or loosen (expand or contract the length of) the compression spring, turn the adjusting nut at the base of the spring.

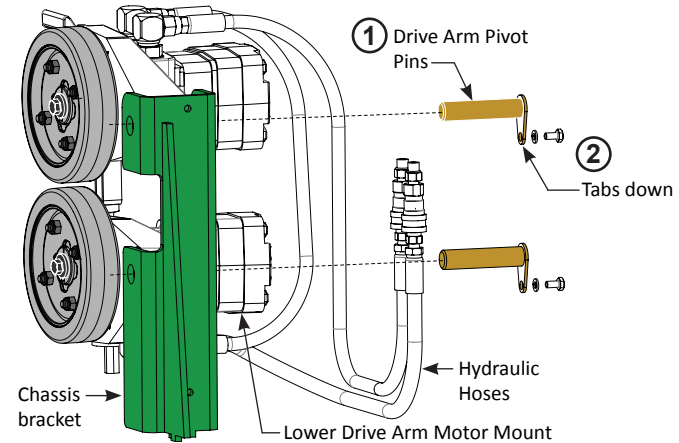

9 Check the compression spring and re-adjust, if necessary.

1. Measure the compression spring. When clamped, it should be 2-inches (5 cm) in height.
2. To expand or contract the length of the compression spring. Use a wrench to turn the adjusting nut at the base of the spring.
3. Reconnect the hydraulic hoses.
4. Turn on power at the Control Box.

Maintenance

For maintenance or troubleshooting issues, refer to the operator's product manual. If you do not have a copy of the manual, it is available at www.hysecurity.com.

Technical Support

For Technical Support, call your installer or authorized HySecurity distributor. Obtain the serial number of your operator before calling. For the name of a distributor near you, call HySecurity at 800-321-9947.

For information about HySecurity training for installers, maintenance personnel and end users, refer to the company website at www.hysecurity.com.

