

HydraSwing™

HydraSwing 40

HydraSwing 40F

HydraSwing 40 Twin

HydraSwing 40F Twin

HydraSwing 80F

HydraSwing 150

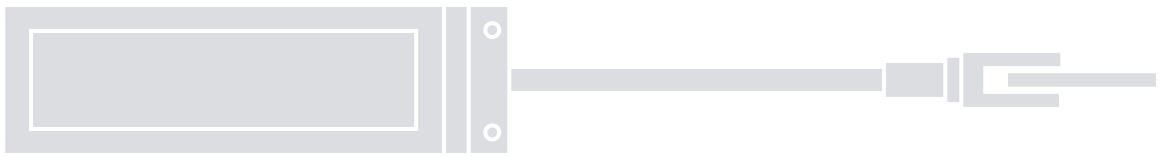

Swing gate operator

EN - Programming and operations manual

Contents

Contents	2
Hydraswing Components.....	5
HydraSupply Components.....	7
Hydraswing Pump Pack Components	8
Safety Information.....	9
Breather Cap Installation And Grounding.....	17
Emergency Stop Button	18
Manual Release Option.....	18
Hand Pump: Manual Release	19
Power.....	20
Installing The Earth Ground	20
Gate Site Considerations.....	21
Wiring AC Power.....	21
Turning The Power Switch On	22
Wiring Diagram: Hydraswing/Hydrasupply.....	23
Wire Sizing And Runs.....	24
Low Voltage Control Wiring.....	24
HydraSwing Wiring Chart (Incoming Power).....	25
Performance Of Operators On 1 And 3 Phase 50/60hz.....	25
Ups Backup Power Options	27
Dc Power Supply (Ups) Connections	27
AC Power Supply With Hyinverter AC.....	28
Initial Setup	29
Open Position And Hydraulic Hose Swap.....	29
Gate Postion Sensor.....	30
Setting The Close & Open Limits.....	30
Adjusting The Pressure Relief Valve.....	31
Modbus Rtu In Hydraswing	32
Adjusting the Gate Speed.....	32
Emergency Fast Operate (Efo).....	33
Setting The Emergency Fast Close.....	33
Installing A Push-Button Device For EFC	33
Entrapment Protection.....	34
Manufacturer's Responsibility.....	36
Pressure Relief Valve – All Hydraulic Operators:	36
Inherent Entrapment Sensor System – Hydraulic Operators (IES).....	36
The Inherent Entrapment Sensor (IES)	37
How Software Handles Monitoring External Entrapment Protection Sensors	38
External Entrapment Protection Sensors: What The Installer Needs To Do.....	38
Supply Power To the Sensors.....	41
Control Panel Overview.....	42
STC Board, Power Supply Board And Display.....	43
Display & Menu Options.....	44
Understanding The Display And Keypad.....	44
Initial Setup.....	46
Initial Setup Using S.T.A.R.T.	46
Menu Mode And The STC Keypad.....	47

Menu Mode Navigation.....	47
Run Mode And The STC Keypad	48
Viewing Gate Operator Scrolling Status.....	48
Stop The Status Display Scrolling.....	50
Change The Contrast On 7 Segment Displays	50
Display Power Saving Mode	50
Check The Software Version.....	50
Check Time And Date	50
User Menu.....	50
Installer Menu.....	54
Adjusting The Gate Speed.....	54
Resetting Open And Close Limits.....	62
Learn Close Limits	63
Learn Open Limits	63
Setting The Close Timer.....	63
Test The Operator.....	64
STC Inputs & Wiring.....	65
Overview Of The STC And Power Supply Board.....	66
Integrating With Security Systems And Hynet™ Gateway.....	67
Smart Touch Controller Inputs.....	68
STC Terminal Inputs.....	68
Connecting Accessory Devices.....	70
User Relays – Programming Procedure.....	71
Hy8relay Module Option.....	74
Bi-Parting & Dual Gate Systems.....	75
Connecting An Interlocked Pair (Dual Gate)	75
Dual Gate Wiring Connections.....	76
Dual Or Sequenced Gates: Power, Software & Accessory Requirements	77
Programming A Dual Gate (Interlocked Pair)	78
Connecting Sequenced Gates	79
Twin Hydraswings	81
Sequenced Gate: Configuration #1	82
Sequenced Gate: Configuration #2.....	83
Vehicle Detector Installation And Loop Layouts	85
Anti-Tailgate Mode (Closing Logic)	85
Tailgate Alert	85
Vehicle Detectors And The Smart Touch Controller	86
Hy5B Installation	86
Test The Vehicle Loop.....	87
Check The Version Of Software.....	87
Install Hy5b Vehicle Detectors	88
Vehicle Detector And Loop Fault Diagnostics	90
Installing Standard 11-Pin Box Type Vehicle Detectors	93
Loop Layouts: Single Lane, Bi- Or Single-Directional	94
Loop Layouts: Two Lane, Bi-Directional.....	95
Photo Eye Installation.....	96
Photo Eyes (Non-Contact) Installation	97
Compatibility.....	98
Installation	98

Configuration.....	98
Photo Eye Connections: Smart Touch & Smart DC Controllers.....	99
Photo Eye Function.....	90
Retro-Reflective Photo Eye Systems.....	100
Using Photo Eye Sensors Instead Of Vehicle Loops.....	101
Photo Eye Alignment Feature.....	102
Installing Gate Edge Sensors.....	103
Compatibility.....	104
Installation.....	104
Edge Sensor Installation Tips.....	104
Gate Edge Function.....	105
Troubleshooting.....	106
System Diagnostic Messages.....	106
Access The Event Log Through The User Menu.....	117
Electrical Issues.....	118
AC-Powered Gate Operators.....	119
Hydraswing Wiring Diagram: Pre-May 2017.....	120
Mechanical Issues.....	120
Hydraulic Issues.....	120
Typical Problems And Troubleshooting Procedures.....	120
General Maintenance.....	122
Smart Touch Analyze And Retrieve Tool (S.T.A.R.T.).....	122
What You Need.....	122
Installing S.T.A.R.T. Software.....	122
Software Maintenance.....	123
Electrical Controls.....	123
Clock Battery Replacement.....	123
Mechanical Maintenance.....	124
Hydraulic System Maintenance.....	124
Brake Valve Adjustments.....	125
Pressure Relief Valve Adjustments.....	126
Open Valve.....	126
Hydraswing Hydraulic Cylinder Maintenance.....	126
Hydraswing Operator Maintenance Schedule.....	127
Hydrasupply Maintenance Schedule.....	128
Wiring Hysecurity Sensors: Smart Touch.....	129
Wiring Tips For Sensor Com Terminal: Smart Touch.....	120
Menu Mode Navigational Tips.....	130
Smart Touch: 2 Ch Wired Edge With Hy2NC.....	130
Smart Touch: Photo Eye Thru Beam (EMX IRB MON).....	132
Smart Touch: Photo Eye / Reflective (E3K R10K4).....	133
Smart Touch: The Solution, Mim-62 (Multi-Input Module).....	133
Smart Touch: Wireless Edge, Wireless Gate Link.....	135
Appendix A - French Translations.....	138
Warranty.....	140
Specifications	142

Contact Information:

Visit support.hysecurity.com for installation manuals, replacement part instructions, part diagrams and more. Qualified HySecurity distributors are experienced and trained to assist in resolving installation problems. For the name of a qualified distributor near you, call HySecurity at 800-321-9947. *Before contacting your distributor or HySecurity Technical Support, obtain the serial number of your operator.

HYDRASWING COMPONENTS

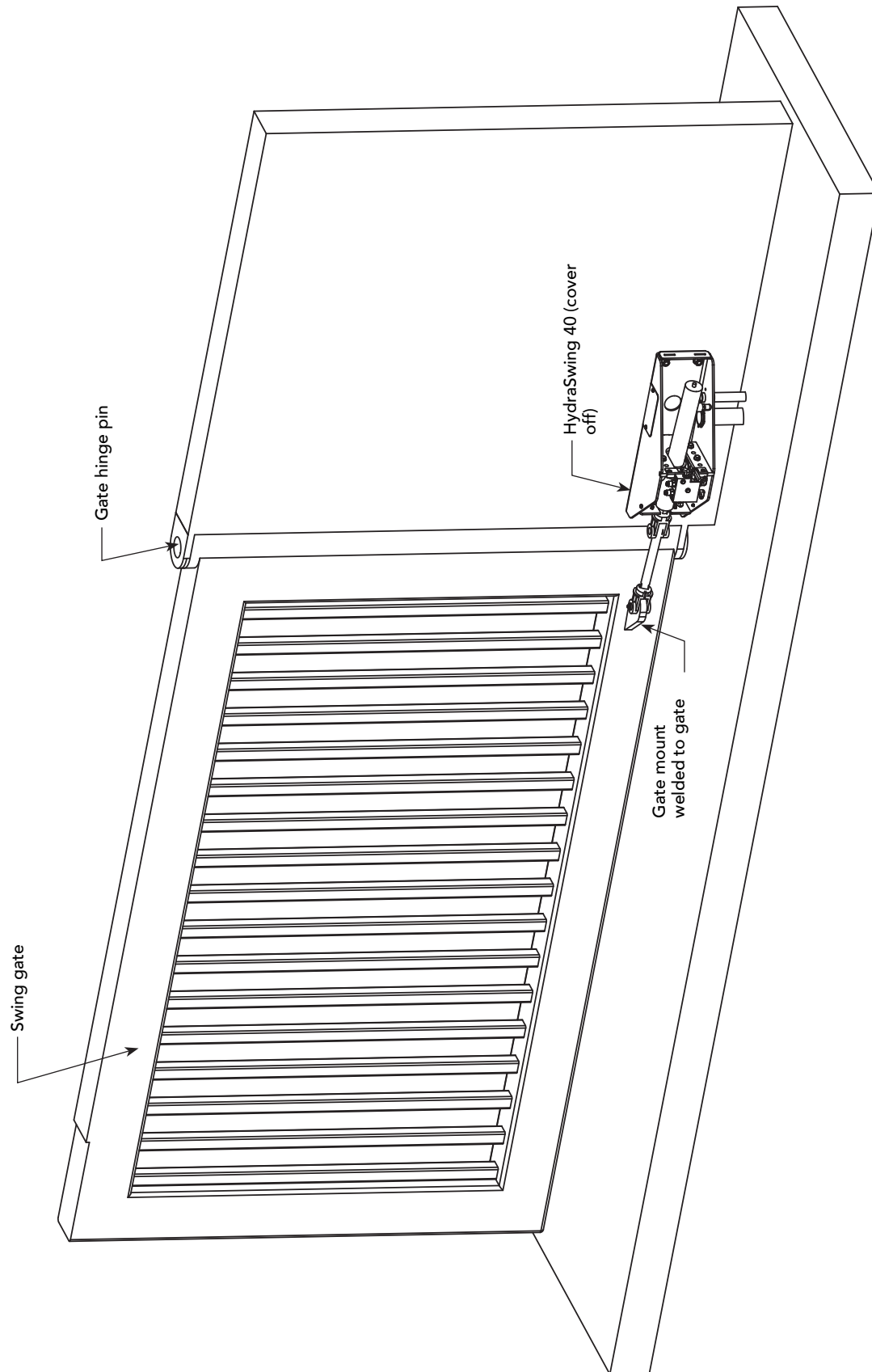

HYDRASWING COMPONENTS

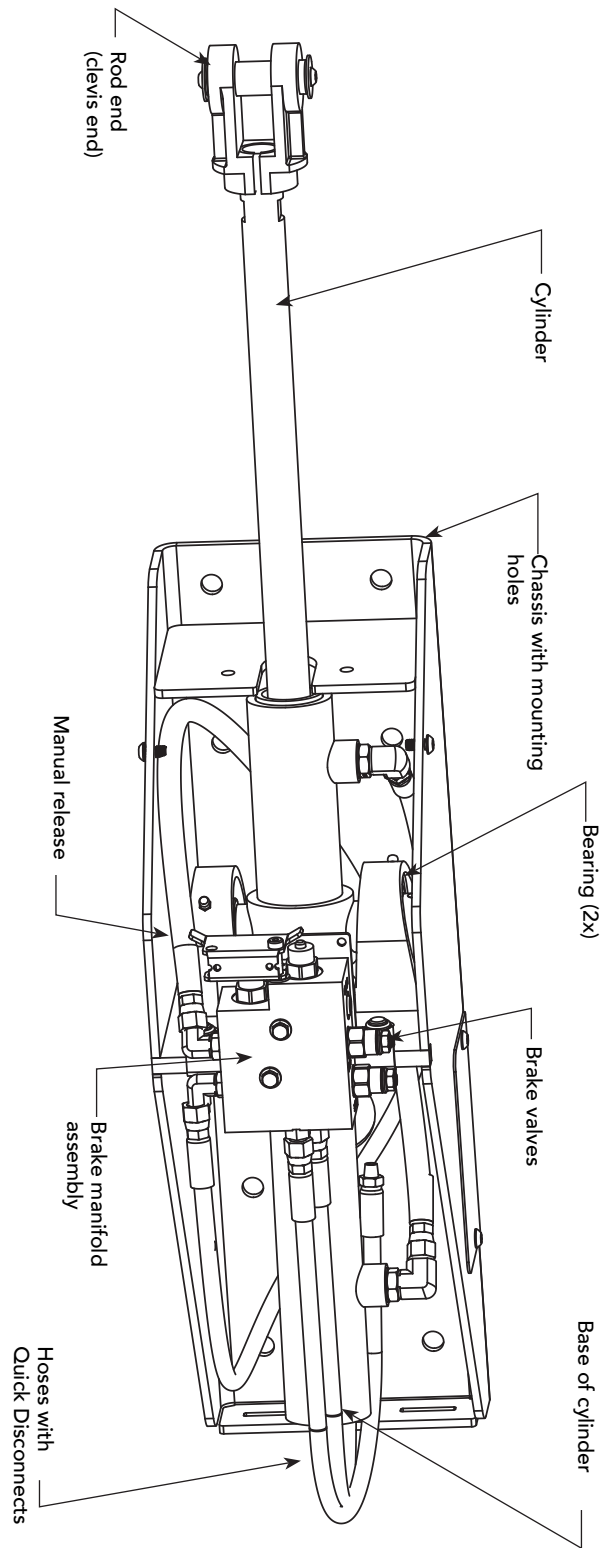

HydraSwing 40, 40F and 40 Twin

HYDRASUPPLY COMPONENTS

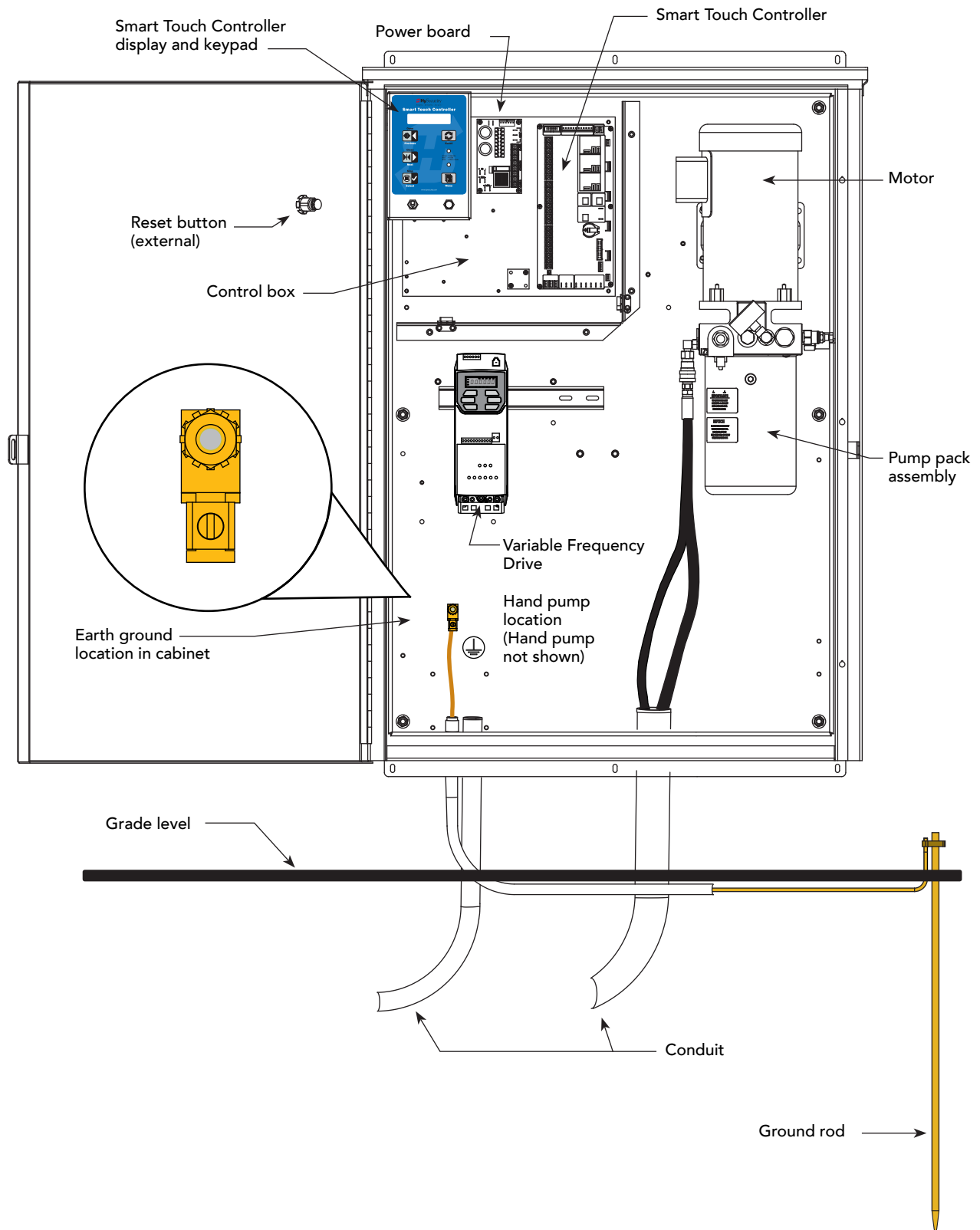

HYDRASWING PUMP PACK COMPONENTS

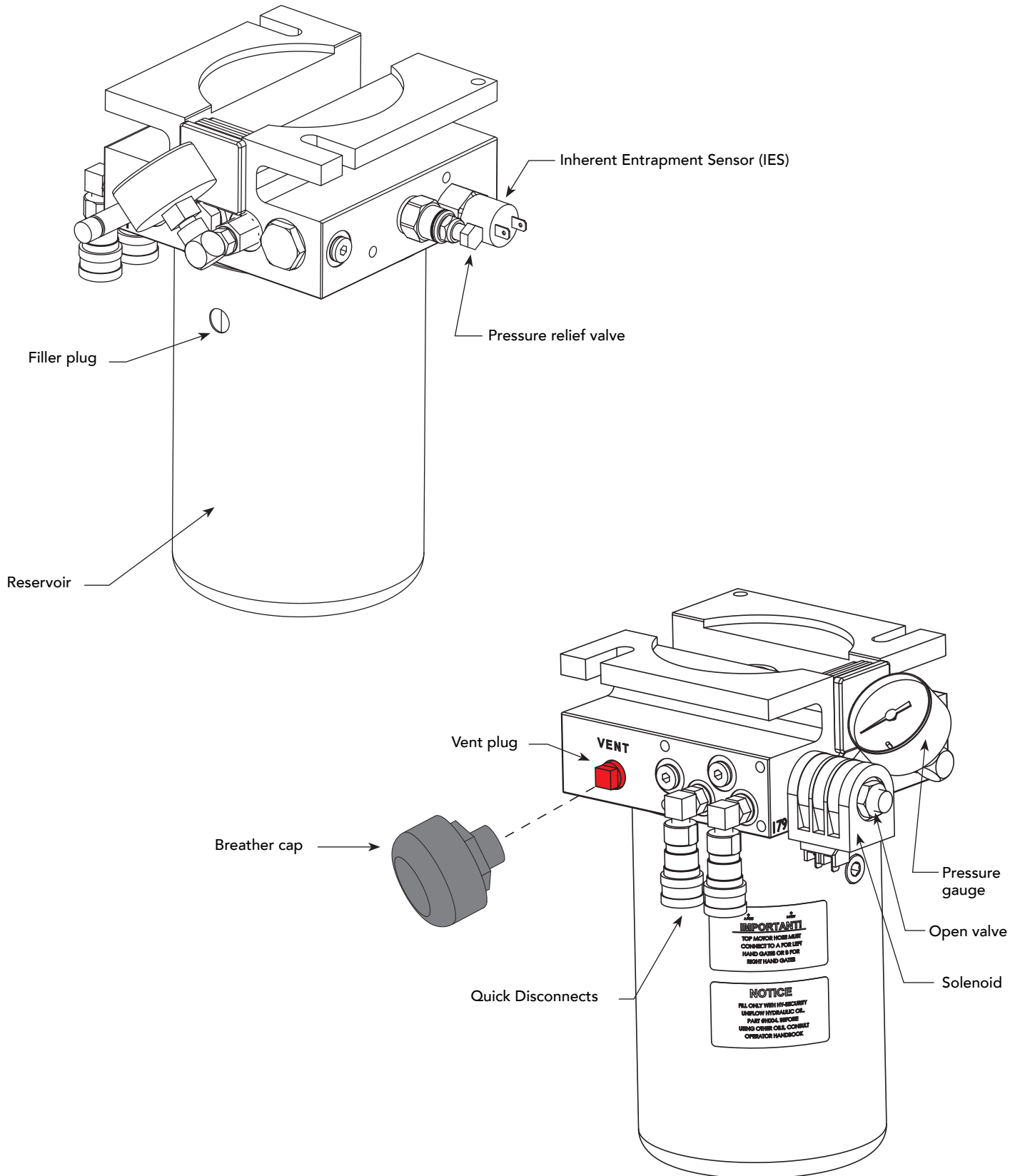

SAFETY INFORMATION

SAFETY MESSAGES

The safety messages below inform you about potential hazards that can result in injury. Safety messages specifically address level of exposure to operator and are preceded by one of four words: **DANGER**, **WARNING**, **CAUTION** or **NOTICE**.



Indicates a hazardous situation which, if not avoided, **WILL** result in **DEATH** or **SERIOUS INJURY**.



Indicates a hazardous situation which, if not avoided, **COULD** result in **DEATH** or **SERIOUS INJURY**.



Indicates a hazardous situation which, if not avoided, **COULD** result in **MINOR** or **MODERATE INJURY**.

NOTICE

Addresses practices not related to personal injury. Indicates damage to equipment is probable if the hazardous situation is not avoided.

COMMON INDUSTRIAL SYMBOLS

These international safety symbols may appear on product or in its literature to alert of potential personal injury hazards. Obey all safety messages that follow these symbols to avoid possible injury or death.

Symbol	Safety Hazard
	Attention - Take Notice
	Danger - Keep Away
	Entrapment Zone
	Possible Pinch Point

IMPORTANT SAFETY INSTRUCTIONS

Hazards, associated with automatic gates, can be reduced with proper site design, installation, and use. Installers, maintenance crews, and owners/users must read and follow the safety requirements found in HySecurity® product manuals.



It is important that only qualified installers handle installation of HySecurity Gate vehicular gate operators. A “qualified” installer has one of the following:



1. A minimum of three years experience installing similar equipment.
2. Proof of attending a HySecurity Technical Training seminar within the past three years.
3. Significant manufacturer endorsements of technical aptitude in gate operator installation and operation.

Underwriter Laboratories (UL) and the American Society for Testing and Materials (ASTM) are responsible for current safety standards and regulations regarding gate operators and automated gates. All aspects of gate installation must comply with the appropriate safety standard. For the most up-to-date ASTM F2200 Gate and Fence Standards, refer to www.astm.org. For UL 325 Safety Standard, refer to www.ul.com. Consult local government agencies for up-to-date rules and regulations as certain municipalities have established licensing, codes or regulations that regulate automated gate system design and installation.

GENERAL SAFETY INFORMATION

A gate operator is only a component in a gate system. The other parts of the gate system can include the gate, the external safety sensors, access controls, and vehicle detectors. To have a gate system that provides for safety, security, and reliable operation it is essential these components operate together as a system. It is the responsibility of the system designer and/or installer to ensure any safety or operational issues have been addressed.

SAFETY INFORMATION

WARNING

To reduce the risk of injury or death:

1. READ AND FOLLOW ALL INSTRUCTIONS.
2. Never let children operate or play with gate controls. Keep the remote control away from children.
3. Always keep people and objects away from the gate. **NO ONE SHOULD CROSS THE PATH OF THE MOVING GATE.**
4. Test the gate operator monthly. The gate **MUST** reverse on contact with a rigid object or stop when an object activates the non-contact sensors. After adjusting the force or the limit of travel, retest the gate operator. Failure to adjust and retest the gate operator properly can increase the risk of injury or death.
5. Use the emergency release only when the gate is not moving.
6. **KEEP GATES PROPERLY MAINTAINED.** Read the user's manual. Have a qualified service person make repairs to gate hardware.
7. The entrance is for vehicles only. Pedestrians must use separate entrance.
8. **SAVE THESE INSTRUCTIONS.**

IDENTIFYING GATE OPERATOR CATEGORY AND UL 325 USAGE CLASS

The UL 325 standard covers gate operators. Within this safety standard several Usage Classes are described that define different types of installations where gate operators can be applied. Some operators are restricted in their usage application. Appropriate Usage Classes are shown in the Specifications.

Class I



Class I: Intended for use in a location of one to four single family dwellings or a parking area associated with one to four single family dwellings.

Class II



Class II: Intended for use in a commercial location or building such as a multi-family housing units (five or more single family units) hotels, garages, retail stores or other buildings servicing general public.

Class III

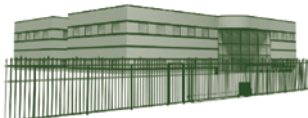

Class III: Intended for use in an industrial location or building such as factories or loading docks or other locations not accessible by the general public.

Class IV



Class IV: Intended for use in guarded industrial locations or buildings such as an airport security area or other restricted access location, not servicing general public, in which access is monitored by security personnel or via closed circuitry.

SAFETY INFORMATION

VEHICULAR TRAFFIC ONLY

WARNING

This automatic gate operator is not designed nor is it intended for pedestrian traffic. Vehicular gate operators must by their nature be powerful to function reliably. This power can cause injury or death. Accordingly, direct all pedestrian traffic to a separate walk-through gate.

Install this gate operator only when:

- The operator is appropriate for the construction of the gate and the usage Class of the gate.
- All openings of a horizontal slide gate are guarded or screened from the bottom of the gate to a minimum of 1.83 m (6 ft) above the ground to prevent a 57.2 mm (2-1/4 in) diameter sphere from passing through the openings anywhere in the gate, and in that portion of the adjacent fence that the gate covers in the open position.
- All exposed pinch points are eliminated or guarded.
- Guarding is supplied for exposed rollers.

The operator is intended for installation only on gates used for vehicles. Pedestrians must be supplied with a separate access opening. The pedestrian access opening shall be designed to promote pedestrian usage. Locate the gate such that persons will not come in contact with the vehicular gate during the entire path of travel of the vehicular gate.

The gate must be installed in a location so that enough clearance is supplied between the gate and adjacent structures when opening and closing to reduce the risk of entrapment. Swinging gates shall not open into public access areas.

The gate must be properly installed and work freely in both directions prior to the installation of the gate operator. Do not over-tighten the operator clutch or pressure relief valve to compensate for an improperly installed, improperly functioning, or damaged gate.

Permanently mounted controls intended for user activation must be located at least 1.83 m (6 ft) away from any moving part of the gate and where the user is prevented from reaching over, under, around or through the gate to operate the controls.

- Exception: Emergency access controls only accessible by authorized personnel (e.g. fire, police, EMS) may be placed at any location in the line-of-sight of the gate.

The Stop and/or Reset button must be located in the line-of-sight of the gate. Activation of the reset control shall not cause the operator to start.

A minimum of two (2) WARNING SIGNS shall be installed, in the area of the gate. Each placard is to be visible by persons located on the side of the gate on which the placard is installed.

For gate operators utilizing a non-contact sensor (Photo Eye):

- See instructions on the placement of non-contact sensors for each type of application.
- Care shall be exercised to reduce the risk of nuisance tripping, such as when a vehicle trips the sensor while the gate is still moving.
- One or more non-contact sensors shall be located where the risk of entrapment or obstruction exists, such as the perimeter reachable by a moving gate or barrier.

For a gate operator utilizing a contact sensor (Edge):

- One or more contact sensors shall be located where the risk of entrapment or obstruction exists, such as at the leading edge, trailing edge, and postmounted both inside and outside of a vehicular horizontal slide gate.
- A hardwired contact sensor shall be located and its wiring arranged so that the communication between the sensor and the gate operator is not subjected to mechanical damage.
- A wireless device such as one that transmits radio frequency (RF) signals to the gate operator for entrapment protection functions shall be located where the transmission of the signals are not obstructed or impeded by building structures, natural landscaping or similar obstruction. A wireless device shall function under the intended end-use conditions.
- One or more contact sensors shall be located on the inside and outside leading edge of a swing gate. Additionally, if the bottom edge of a swing gate is greater than 152 mm (6 in) but less than 406 mm (16 in) above the ground at any point in its arc of travel, one or more contact sensors shall be located on the bottom edge.

USE OF VEHICLE DETECTORS

Use of vehicle detectors (loop detectors) is strongly encouraged to prevent damage to vehicles caused by gates closing on them. This is not considered to be a safety item as vehicle detectors cannot provide protection to pedestrians. In some situations, photoelectric devices may be used as vehicle detectors, but should be wired accordingly.

GATE CONSTRUCTION AND SAFETY

Gate construction plays a very important role in ensuring the safety of any automated gate system. The standard for gate construction is ASTM F2200. Below are key areas to address in gate design for safety. For complete information consult the standard. Copies of the standard are available at:

<https://www.astm.org/Standards/F2200.htm>.

SAFETY INFORMATION

Another source of information is available from DASMA, the Door and Access System Manufacturer's Association. The Association publishes Technical Data Sheets, one of which concerns ASTM F2200. For more information, see:

<http://www.dasma.com/PDF/Publications/TechDataSheets/OperatorElectronics/TDS370.pdf>.

General Requirements for gate construction:

- Gates shall be constructed in accordance with the provisions given for the appropriate gate type listed. Refer to ASTM F2200 for additional gate types.
- Gates shall be designed, constructed and installed to not fall over more than 45 degrees from the vertical plane, when a gate is detached from the supporting hardware.
- Gates shall have smooth bottom edges, with vertical bottom edged protrusions not exceeding 0.50 in (12.7 mm) other than the Exceptions listed ASTM F2200.
- The minimum height for barbed wire shall not be less than 6 ft (1.83 m) above grade. The minimum height for barbed tape shall not be less than 8 ft (2.44 m) above grade.
- An existing gate latch shall be disabled when a manually operated gate is retrofitted with a powered gate operator.
- A gate latch shall not be installed on an automatically operated gate.
- Protrusions shall not be permitted on any gate. Consult ASTM F2200 for exceptions.
- Gates shall be designed, constructed and installed such that their movement shall not be initiated by gravity when an automatic operator is disconnected.
- For pedestrian access in the vicinity of an automated vehicular gate, a separate pedestrian gate shall be provided. The pedestrian gate shall be installed in a location such that a pedestrian shall not come in contact with a moving vehicular access gate. A pedestrian gate shall not be incorporated into an automated vehicular gate panel.
- Any non-automated gate that is to be automated shall be upgraded to conform to the provisions of this specification.
- This specification shall not apply to gates generally used for pedestrian access and to vehicular gates not to be automated.
- Any existing automated gate, when the operator requires replacement, shall be upgraded to conform to the provisions of this specification in effect at that time.

The following provisions shall apply to Class I, Class II, Class III, and Class IV vehicular horizontal swing gates:

Gates shall be designed, constructed and installed so as not to create an entrapment area between the gate and the supporting structure or other fixed object when the gate moves toward the fully open position, subject to the following provisions.

The width of an object (such as a wall, pillar or column) covered by a swing gate when in the open position shall not exceed 4 inches (102 mm), measured from the centerline of the pivot point of the gate. Exception: For a gate that is not in compliance with this provision, the defined area shall be subject to the entrapment protection provisions of UL 325.

Except for the zone specified above the distance between a fixed object such as a wall, pillar or column, and a swing gate when in the open position shall not be less than 16 inches (406 mm). Exception: For a gate that is not in compliance with this provision, the defined area shall be subject to the entrapment protection provisions of UL 325.

EXTERNAL ENTRAPMENT PROTECTION SENSORS

Most Nice | HySecurity gate operators are equipped with a Type A, Inherent Entrapment Sensor (IES). UL 325 Safety Standard compliance requires an additional means of entrapment protection that includes installation of external entrapment protection sensors, the number of which depends on entrapment hazards that exist at each particular installation.

To comply with UL 325, the following external sensors may be used:

- Contact sensors, such as edge sensors
- Non-contact sensors, such as photo eyes
- Built-in Type C device (Mercury 310 only)

Site designer or installer can choose photo eyes, edge sensors, internal Type C sensor, or a combination of these devices. Whatever devices are used, protection in both opening and closing directions of gate travel must be provided, as well as and where a risk of entrapment is present.

UL 325 Safety Standard for automatic sliding gates specifically requires that edge sensors, photo eyes, or a combination of both devices be installed to protect against pedestrian entrapment in BOTH directions of gate travel and wherever entrapment hazards exist.

PHOTO EYES: One or more non-contact sensor (photo eyes) shall be located where entrapment risk or obstruction exists, such as perimeter reachable by a moving gate.

Care shall be exercised to reduce the risk of nuisance tripping, such as when a vehicle trips the sensor while the gate is moving.

SAFETY INFORMATION

EDGE SENSORS: One or more contact sensors (edge sensors) shall be located at leading edge, trailing edge, and post-mounted, both inside and outside of a sliding gate.

One or more contact sensors shall be located on the inside and outside leading edge of a swing gate. Additionally, if the bottom edge of a swing gate is greater than 6" (152mm) but less than 16" (406mm) above the ground at any point in its arc of travel, one or more contact sensors shall be located on the bottom edge.

SENSOR SECURITY: A hard-wired contact sensor shall be located and its wiring arranged so that communication between sensor and gate is not subjected to mechanical damage.

TYPE A ENTRAPMENT PROTECTION: In Type A entrapment protection, the controller monitors the electrical resistance of the actuator motors, so if a moving gate comes up against the physical resistance of an immovable object, it will cause the gate to stop, hence limiting the force..

TYPE C ENTRAPMENT PROTECTION: In Type C entrapment protection, the controller monitors the actuator encoder output, and if there is an unexpected decrease in speed, it will cause the gate to stop, hence limiting the force.

SENSOR FUNCTION and COMMUNICATION: A wireless sensor that transmits its signal to gate operator must be located so its signal is not impeded by building structures or other obstructions. All sensors must be installed so that they function as intended for end-use conditions.

UL 325 LISTING: Edge sensors and photo eyes must be tested and labeled as "Recognized Components" or otherwise certified to UL 325 requirements in order to

be deemed acceptable for use in a gate operator. Study Important Safety Instructions and consider your specific installation to determine where greatest entrapment risks exist. Locate edge sensors and/or photo sensors accordingly. Be certain that a sufficient number of sensors are used so that pedestrians are protected from entrapment in both directions of gate travel and all hazard areas are fully protected. Most HySecurity gate operators require external entrapment sensors that utilize Normally Closed (NC) contact means of monitoring. HySecurity gate operators utilizing the SmartCNX Controller require external entrapment sensors that have a 10k Ohm or 4-wire pulsed monitoring scheme. Refer to UL website at www.ul.com for most up-to-date list of gate operator safety standards (UL 325). Mercury 310 controller can monitor 10k sensors as well as BlueBus photo eyes.

CAUTION

A contact or non-contact sensor is also required to protect against possible entrapment if gate opens to a position less than 16 inches from any object, such as a post or wall.

RECOMMENDED EXTERNAL ENTRAPMENT PROTECTION SENSORS LIST

UL 325 Standard:

- The operator shall monitor for the presence of every device at least once during each open and close cycle (32.1.8).
- It shall not be possible to make simple modifications in the field by adding, suppressing or changing, either on the operator or external entrapment protection device(s), to bypass, interfere with, or otherwise defeat the monitoring function. (32.1.10).
- Entrapment zones are now defined for each gate type (4.23, 4.24, 4.29, 4.34).

Swing Gates: To enable fully automatic operation, all SWING gate operators will require a minimum of ONE monitored external entrapment protection sensor to protect entrapment zones in either the open or close direction of travel. However, an additional monitored sensor is required if there is a risk of entrapment in both directions of gate travel.

Preferred solution for swing gates: A photo eye for the close direction and/or a hard-wired wraparound edge sensor on the leading edge of the gate, which protects for both directions of gate travel.

IMPORTANT!

Installers must assess each specific site and install sensors that protect all potential entrapment zones.

For more information visit Gate Safety at www.hysecurity.com/gatesafety or see latest operator manuals at <https://support.hysecurity.com/hc/en-us>

SAFETY INFORMATION

The sensors shown in the table below have been tested with Nice | HySecurity gate operators by an independent laboratory and certified to comply with UL 325 7th Edition. Select sensors from this list for UL compliant gate automation solutions. Contact the sensor manufacturer for specific recommendations for use.

Nice HySecurity Recommended Sensors					Control Boards				
	Mfg. Part # or Model	Brand	Nice Hysecurity Part #	Max Range	Smart Touch	Smart DC	SmartCNX	1050	Mercury 310
Photo Eyes (Retro -reflective)	E3K-R10K4-NR-1	Omron	MX000999	40 ft	•	•	•		
	NIR-50-325	EMX	-	45 ft	•	•	•	•	•
	IRB-RET	EMX	-	53 ft	•	•	•	•	•
	E-931-S50RRGQ	Seco-Larm	-	46 ft	•	•	•		•
Photo Eyes (Thru-Beam)	Blue Bus Era Photo Eyes	Nice HySecurity	EPMB/A EPMOB/A	45 ft			•	•	•
	OVS-50TNR	Optex	-	33 ft	•	•			
	IRB-MON	EMX	MX3990	65 ft	•	•	•		•
	E-960-D90GQ	Seco-Larm	-	90 ft	•	•	•		•
Edge Sensors	Sentir Series	ASO Safety	"AS1502- AS1501-"		•	•	•	•	•
	CPT210-2U-#-T2	Miller Edge	-		•	•	•	•	•
Edge Sensor Converters	Hy2NC (Converts 10K to NC Monitoring)	HySecurity	MX4018		•	•			
	GEM103 (Converts 10K to Pulsed Monitoring)	Miller Edge	-					•	
Edge Wireless Kits	iGAZE RE Kit	Transmitter Solutions	-		•	•	•	•	•
	WEL-200	EMX	-		•	•	•	•	•
Multi-Input Module	The Solution – MIM-62	Miller Edge	-		•	•	•		•

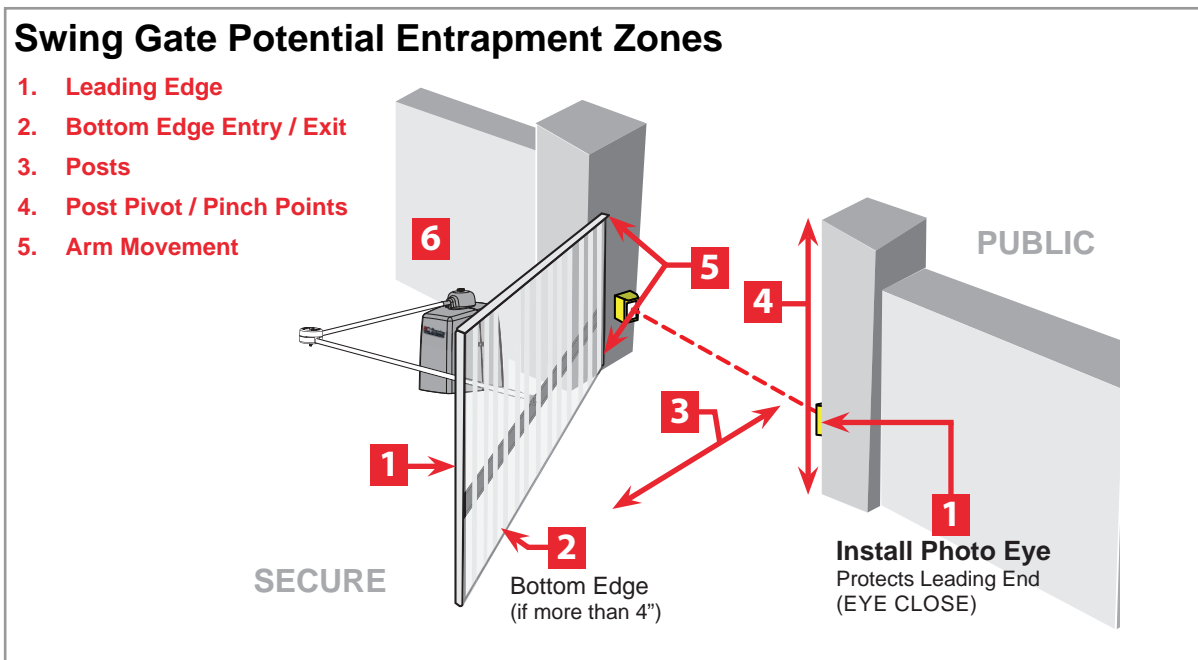

SAFETY INFORMATION

ELECTRICAL SAFETY

- Turn gate operator and all circuit breakers OFF before performing maintenance on the gate operator or making contact with output receptacles.
- Never insert any objects into output receptacles during operation. The possibility exists of electrical shock, electrocution, or death.
- Never let power wires lay in water.
- Never use damaged or worn wire when connecting equipment. Inspect for cuts in the insulation.
- Never grab or touch a live power cord or cable with wet hands. The possibility exists of electrical shock, electrocution or death.
- Always make certain that proper power has been selected for the job. See Cable Selection Chart in this manual.

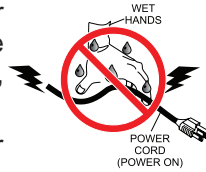

GROUNDING SAFETY

- Always make sure that electrical circuits are properly grounded to a suitable earth ground (ground rod) per the National Electrical Code (NEC) and local codes. Severe injury or death by electrocution can result from operating an ungrounded operator.
- Never use gas piping as an electrical ground.



BATTERY SAFETY

HySecurity operators use sealed Absorbed Glass Mat (AGM) batteries and HySecurity highly recommends replacing used batteries with new AGM-type batteries.

CAUTION

Batteries used with HySecurity gate operator contain materials considered hazardous to environment. Proper battery disposal is required by federal law. Refer to *Hazardous Waste Regulations* federal guidelines.

To reduce risk of fire or injury to persons:

- Observe polarity between batteries and charging circuit.
- Never mix battery sizes, types, or brands. Charging circuit on HySecurity DC operators is designed for AGM-type batteries, not flooded lead acid-type batteries.
- Exercise care in handling batteries. Be aware metal found in rings, bracelets, and keys can conduct electricity, short batteries, and cause potential injury.
- Do not open or mutilate batteries. Battery cells contain corrosive materials which may cause burns and other injuries. Material within batteries is toxic.
- Always dispose of batteries properly. Do not place batteries in fire. Battery cells may explode. Follow federal guidelines for proper disposal of hazardous waste.
- Always keep battery cables in good working condition. Repair or replace all worn cables.
- Replace batteries according to instructions found in *DC Battery Replacement*.
- Do not charge frozen battery. Battery can explode. If frozen, warm the battery to at least 61°F (16°C).



ENVIRONMENTAL SAFETY/HAZARDOUS MATERIALS AND PROPER DISPOSAL

Decommissioning is a controlled process used to safely retire a piece of equipment that is no longer serviceable. If the equipment poses an unacceptable and unreparable safety risk due to wear or damage or is no longer cost effective to maintain (beyond life-cycle reliability) and is to be decommissioned (demolition and dismantlement), be sure to follow rules below.



- Do not pour waste or oil directly onto the ground, down a drain or into any water source.
- Contact your country's Department of Public Works or recycling agency in your area and arrange for proper disposal of any electrical components, waste or oil associated with this equipment.
- When the life cycle of this equipment is over, remove battery and bring to appropriate facility for lead reclamation. Use safety precautions when handling batteries that contain sulfuric acid.
- When the life cycle of this equipment is over, it is recommended that the frame and all other metal and plastic parts be sent to a recycling center.

Metal and plastic recycling involves the collection of metal and plastic from discarded products and its transformation into raw materials to use in manufacturing a new product.

Recyclers and manufacturers alike promote the process

SAFETY INFORMATION

of recycling metal and plastic. Using a metal and plastic recycling center promotes energy cost savings.

WIND LOAD

When the IES (type A sensor) trips, it sends a signal to gate operator to stop and reverse direction. This feature may be falsely triggered in excessively windy conditions because wind itself, acting over surface area of gate panel, can provide necessary force to trigger IES.

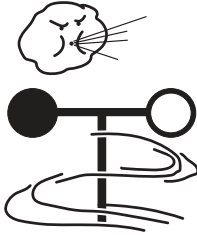

CAUTION

Do not adjust IES sensitivity/Force setting to accommodate for inappropriately designed gate panels. Loss of IES sensitivity increases mechanical wear on gate hardware and gate operator. It may also pose a safety hazard. Compensating for wind loads by adjusting IES may set IES sensitivity to a level which, when encountering an obstruction, ignores obstruction and fails to reverse direction.

MAINTENANCE OF GATE SYSTEMS

To keep your automated gate system performing both safely and reliably it is important to ensure that the components of that system are functioning properly.

At least monthly:

- Disconnect the gate operator and manually move the gate through its range of travel. Note any squeaks from rollers or hinges or areas of binding. The gate should travel smoothly and quietly throughout its range. If it does not, contact a gate professional to correct the problem.
- Reconnect the gate operator and perform the following tests:
 - With the gate opening, block any photo eyes and/or depress any safety edges used to protect the open direction. The gate should stop and/or reverse.
 - With the gate closing, block any photo eyes and/or depress any safety edges used to protect the close direction. The gate should stop and/or reverse.
 - Using a suitable obstruction in the path of the gate (a solid, immovable object), run the gate in the open direction until it contacts the obstruction. The gate should stop and reverse, or it will just stop if a Type C sensor is engaged before the Type A sensor is tripped.
 - Using a suitable obstruction in the path of the gate (a solid, immovable object), run the gate in the close direction until it contacts the obstruction. The gate should stop and reverse, or it will just stop if a Type C sensor is engaged before the Type A sensor is tripped.

NOTICE

For more information on Gate Safety, visit:
<https://support.hysecurity.com/hc/en-us/categories/360003177593-Safety>.

BREATHER CAP INSTALLATION AND GROUNDING

The gate operator has a vent plug that keeps the hydraulic fluid from spilling during shipment. The vent plug must be replaced by the breather cap before operating the swing gate.



Failure to perform the following procedure will cause premature pump shaft failure and void the Limited Warranty.

1. Remove the vent plug and discard it.
2. Replace the vent plug with the breather cap.

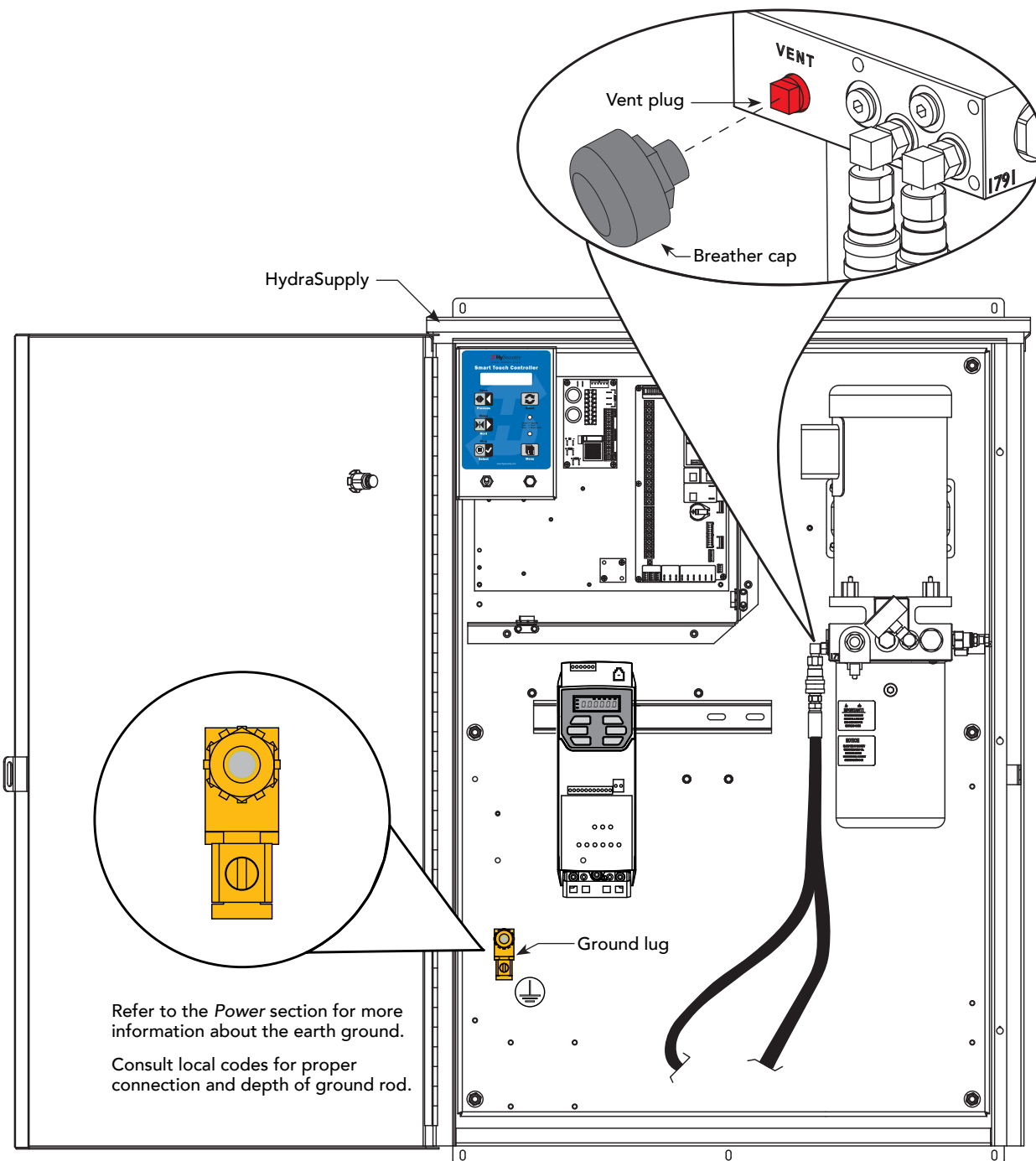

Refer to the *Power* section for more information about the earth ground.
Consult local codes for proper connection and depth of ground rod.

EMERGENCY STOP BUTTON

Make sure all users of the gate know where the emergency stop button is located (see illustration). It complies with UL 325 Safety Standards requirements.

Pressing the emergency stop button while the gate is opening or closing disables the automatic close timer and stops gate travel. Gate travel remains stopped until the operator receives another open or close signal.

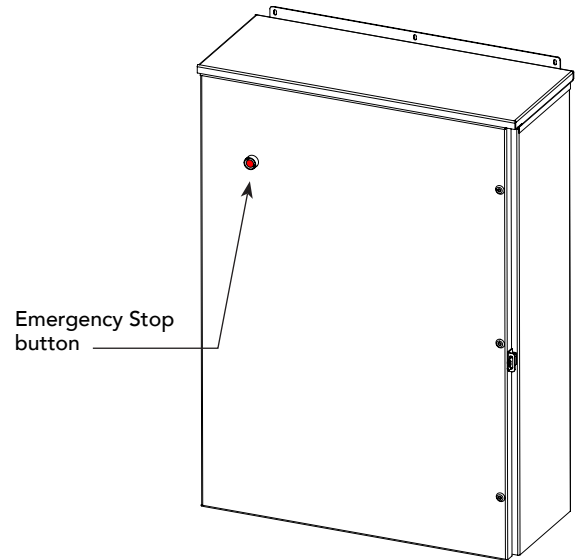

HydraSupply

MANUAL RELEASE OPTION



Before attempting a manual release, make sure the gate is not in motion and power is disconnected (turned OFF).

The manual release option can be found on the brake manifold.

To move the gate manually, turn OFF the power switch on the control box in the HydraSupply cabinet, and then simply push the release lever, as shown in the illustration.

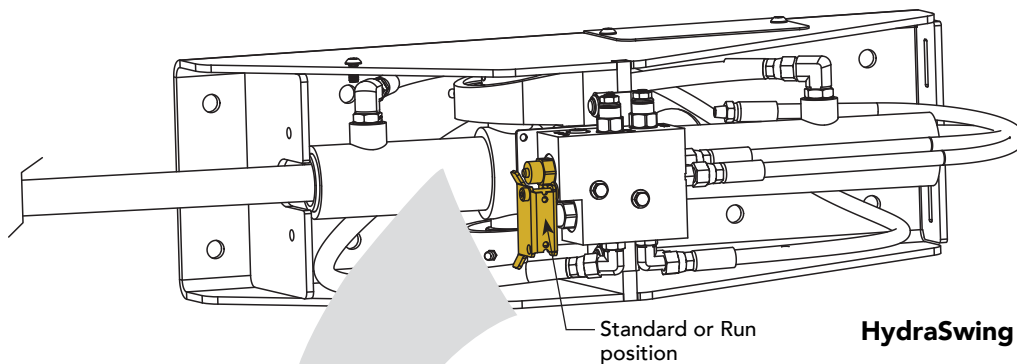

HydraSwing 40, 40F, and 40 & 40F Twin



For the HydraSwing 80F or 150 models, pushing close while using the manual release option may cause an air pocket to form in the hydraulic cylinder and cause overflow from the reservoir. If you notice fluid leakage, stop gate travel immediately and use the hand pump.

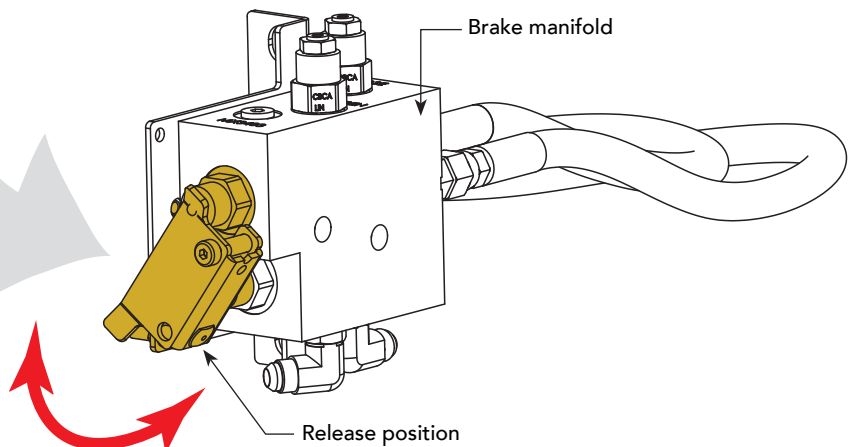

HAND PUMP

A hand pump kit is used to manually operate the hydraulic mechanism that secures the gate. In the event of a power failure, manual operation can be achieved by accessing the hydraulics cabinet. Follow the steps below to open or close the gate:

NOTE: A manual release mechanism exists on the brake manifold assembly. Refer to *Manual Release Option* on page 18.

Open the Gate using the Hand Pump

1. Open the HydraSupply cabinet.
2. Turn the power switch OFF.
3. Locate the hand pump and the Knurled Knob on the Open Valve.
4. Firmly, pull and twist the knurled knob counterclockwise. Release the knob so that it remains in the open position.

NOTE: If the valve re-seats itself, repeat the pull and twist in the opposite direction until the valve remains open.

5. Begin pumping the handle up and down. As hydraulic fluid is pumped into the cylinder, it begins to move the gate. It is a slow process.
6. Continue pumping until the gate reaches full open position.
7. Turn the knurled knob so it springs back to the closed position.

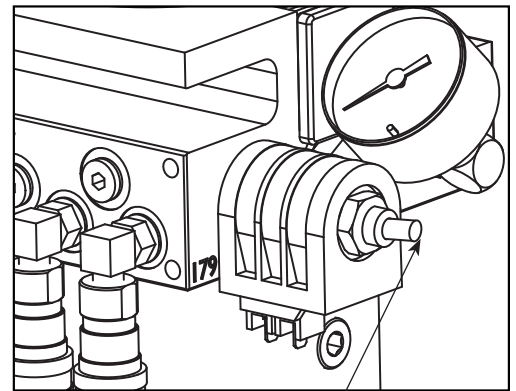

Knurled knob

Close the Gate using the Hand Pump

1. Check that the knurled knob is in the closed position. Begin pumping the handle up and down. The gate slowly closes with the pumping motion.
2. The gate will maintain its position whenever you stop pumping.
3. Continue pumping until the gate reaches the full closed position.

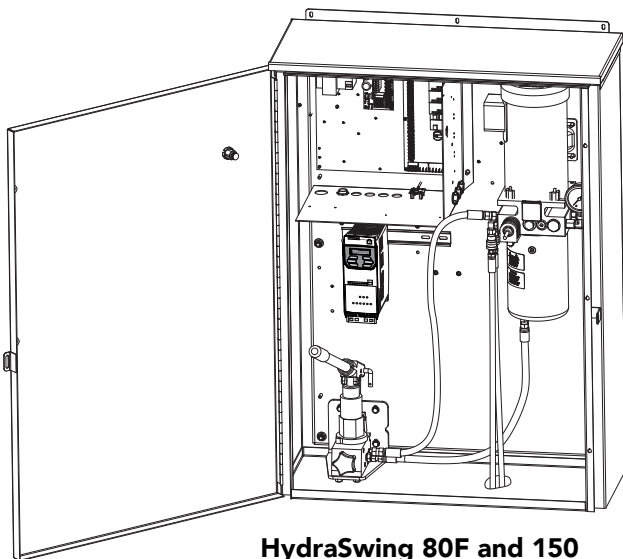

HydraSwing 80F and 150

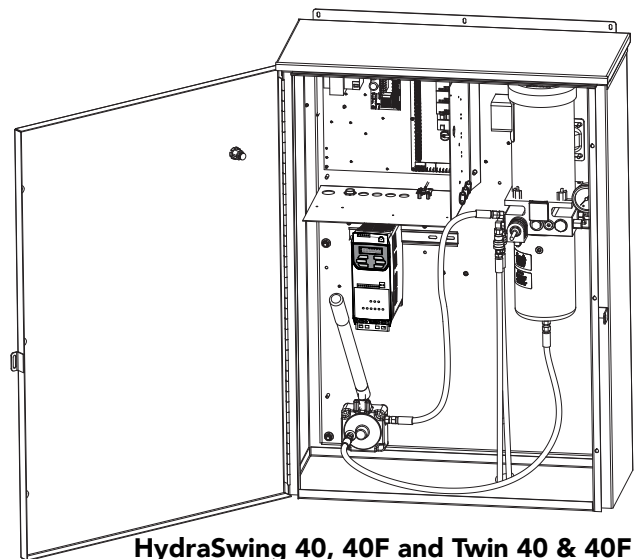

HydraSwing 40, 40F and Twin 40 & 40F

How to wire the operator is presented in the *Installation Instructions*, but detailed information about the earth and equipment ground, wiring to AC power and the availability of UPS systems are described in this section.

[Supplemental documents](#) to this section include:

- DC Power Supply with HyCharger DC
- AC Power Supply with HyInverter AC

INSTALLING THE EARTH GROUND

An earth ground refers to the grounding rod and accompanying equipment ground which need to be installed to safeguard against potential electrical shock and damage to personnel and equipment.



The potential for lightning discharge exists with all gates, fences and gate operators. National Electric Code (NEC) - Article 250 requires a separate earth ground in addition to the required equipment ground.

HySecurity recommends grounding the operator with a separate earth ground rod (or a similar device in the case of crash products) to shield the operator against electromagnetism and other electrical signals that may cause, erratic operation with, or damage to, the Smart Touch Controller and other electrical parts.

For earth grounding requirements in the U.S.A., refer to the National Fire Protection Association (NFPA) 780 - Standard for the Installation of Lightning Protection Systems. Highlights of the standard include:

- The ground rod must be UL listed copper-clad steel, solid copper, hot-dipped galvanized steel, or stainless steel. Minimum requirements: $\frac{5}{8}$ inch (16 mm) diameter and 8 feet (244 cm) in length.
- The ground rod is driven into the earth (refer to local codes for proper depth requirements).
- The ground rod is electrically bonded to the chassis with a single length of un-spliced 6 AWG copper wire less than 3 feet (91 cm) long. Due to the large concrete foundation on crash products, make the necessary adjustments to accommodate for earth ground requirements.
- Local jurisdictions may impose other requirements above the NEC, Article 250 and NFPA 780 Consult the local codes and regulations regarding requirements in your area.

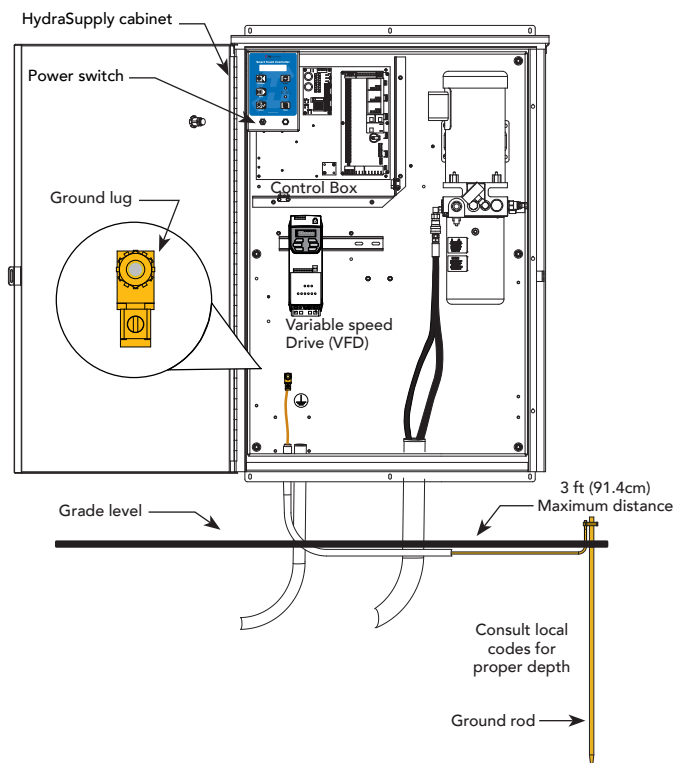

NOTICE: Properly grounding the gate operator is critical to gate operator performance and the life of its electrical components. Use sufficient wire size during installation. If you do not ground the operator with a separate earth ground, you risk voiding the HySecurity Warranty.

GATE SITE CONSIDERATIONS

HySecurity gate operators are intended for permanent installation. Make sure you prepare the site with the following considerations:



Each gate operator is built to run on a specific line power voltage and phase. Failure to ensure the source voltage (phase and frequency match what is specified for the equipment), may result in severe damage to the equipment.

- Make sure all electrical wiring is properly routed via conduits.
- Check the distance of the wiring run from the main panel to the gate operator. Make sure the wire size of the branch circuit supplying power to the gate operator is large enough to avoid excess voltage drop. Refer to *Wire Sizing and Runs* on page 24.
- Make sure the available power source matches the electrical requirements specified on the voltage nameplate.
- Make sure a 20-amp circuit (minimum) protected with a 20-amp Inverse Time Breaker is provided for all AC power connections.
- Verify that the operator is electrically grounded per NFPA 780 and NEC Article 250 and local codes.

WIRING AC POWER

The HydraSwing has separate *Installation Instructions* that explain how to connect to AC power. For reference purposes, the same information is provided below.

In-rush Current is the current needed to start the electric motor spinning in the proper direction (CCW). It may take as much as 6 to 9 times the in-rush current to start one of the heavy duty operators.

NOTE: Use a 20A (minimum) slow blow (thermal) circuit breaker for all AC motors.

Size the primary wires. Consider the voltage, horsepower, and length of the wire run from the main power panel.

Make sure you have the proper voltage and conversion of voltage taps at the motor and transformer.



Turn OFF AC power at the source (circuit breaker panel) before accessing the wires in the HydraSwing. Follow facility Lock Out/Tag Out procedures. Make sure all power switches are in the OFF position. Follow all electrical code standards and regulations.

1. **Connect to Power:** Three pig tails and a ground are available for connection to a 3 Phase power source (3Ø) on the back of the keypad display enclosure.
2. **Connect AC Power:** Wire nut the incoming power wires to their appropriate pig tails. Attach the ground wire to the chassis. A wiring diagram is provided in the appendix. Note that for 1Ø wiring, only the two outside connections/pig tails are used.

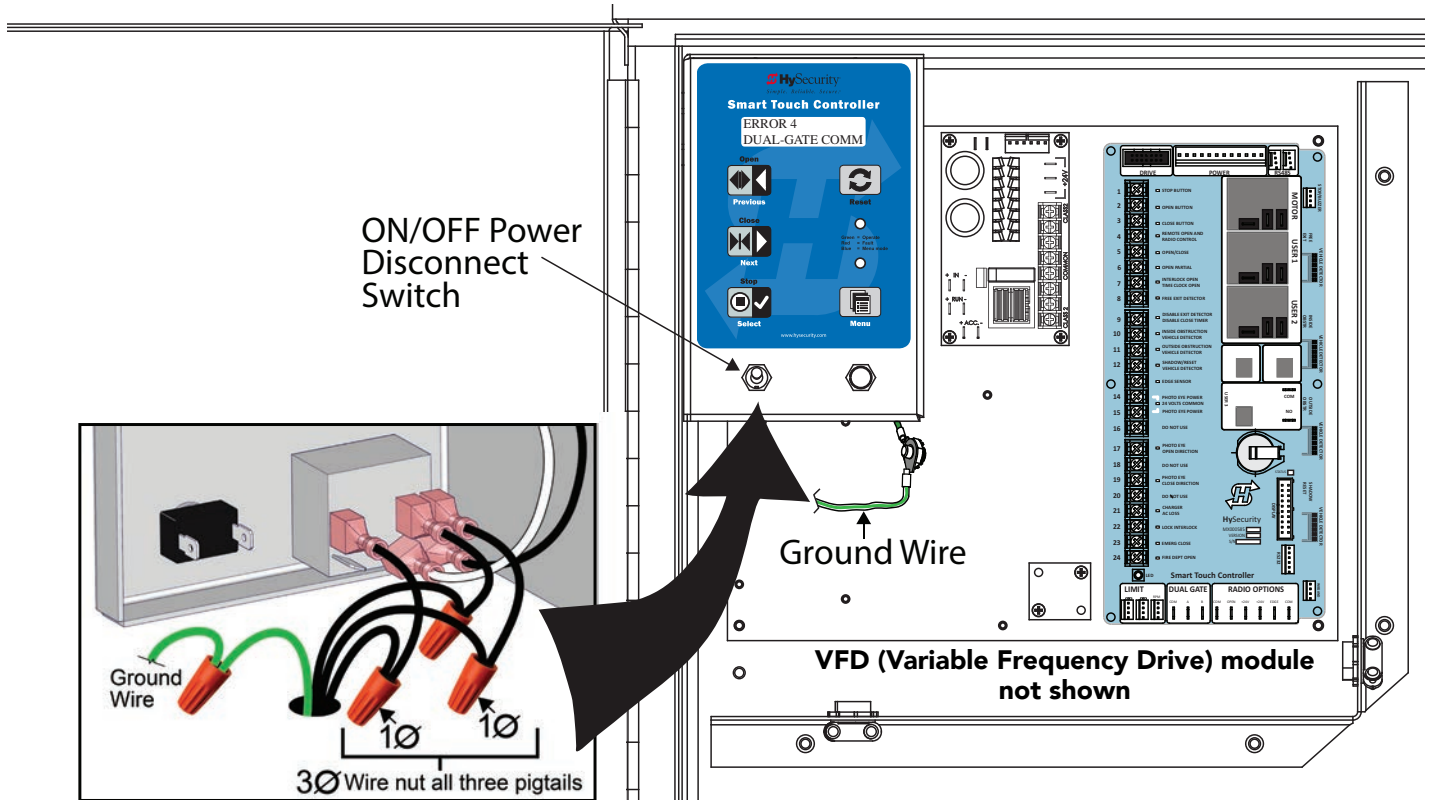

CAUTION * Variable Frequency (VF) operators: Make sure the connection wires match the voltage found on the operator's nameplate.

CAUTION

Wiring of gate operators must conform to NFPA and NEC standards and comply with all local codes. When the installation is compliant and complete, turn on AC power at the source and at the control box.

Turning the Power Switch ON

The AC power disconnect switch (ON/OFF switch) is located on the enclosure with keypad display. See the illustration on the previous page.

When power is turned ON, a green status light on the Smart Touch Controller blinks. The status light appears below the disc battery and indicates that the processor is receiving power. For more information, refer to *STC Board, Power Supply Board and Display* on page 43.

Green LED flashes indicating processor is receiving power.

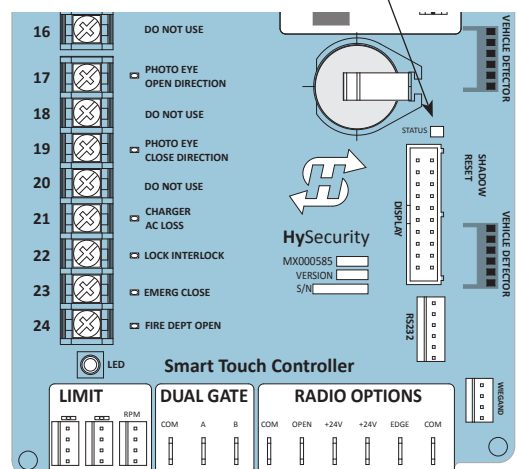

WIRING DIAGRAM: HYDRASWING/HYDRASUPPLY

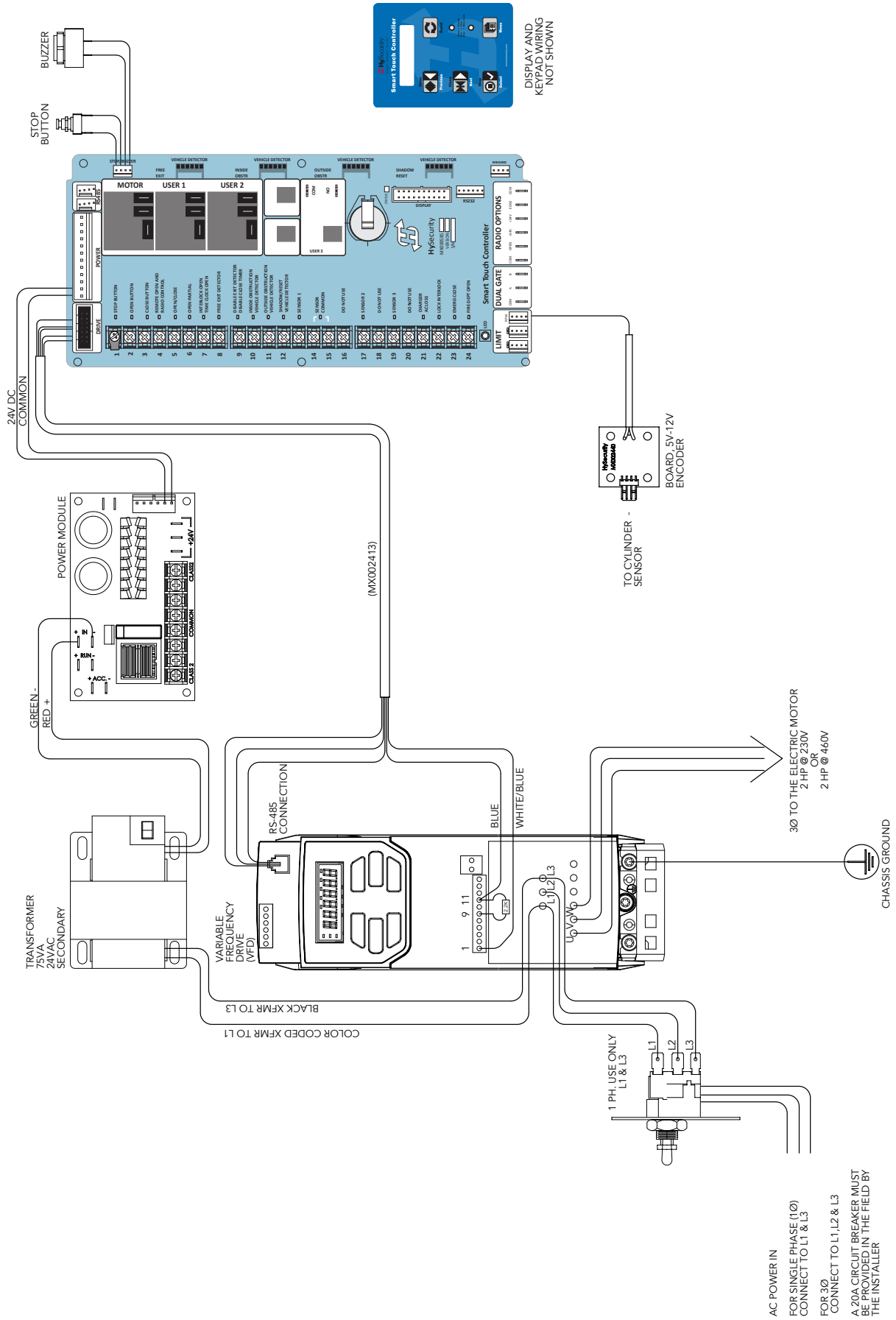

WIRE SIZING AND RUNS

Supplying a gate operator with the correct electrical service is crucial to the performance of the operator and the life of its electrical components. If the wire size used is too small, the voltage loss, especially during motor startup, will prevent the motor from attaining its rated horsepower. The percentage of horsepower lost is far greater than the percentage of voltage loss.

A voltage loss can also cause the control components to chatter while the motor is starting, substantially reducing their life due to the resultant arcing. There is no way to restore lost performance resulting from undersized wires, except to replace them. To avoid costly rewiring, be sure to choose a sufficient wire size during site planning phases and at initial installation.

The tables on the following page are based on copper wire and allow for a 5% voltage drop. The ampere values shown are the service factor ampere rating of the motor (maximum full load at continuous duty). At minimum, a 20A circuit (protected with a 20A Inverse Time Breaker) should be provided.

Always connect electrical power and ground the operator in accordance with the NFPA 780 & NEC, Article 430 and Article 250. Research and adhere to other local codes that may apply.

Low Voltage Control Wiring

The Smart Touch Controller has very sensitive control inputs. The following is a chart of maximum distances for wire size:

Wire Size	Maximum Distance
18 ga	7.0 miles (11 km)
20 ga	3.5 miles (5.6 km)
22 ga	2.7 miles (4.3 km)
24 ga	2.0 miles (3.2 km)
26 ga	1.0 mile (1.6 km)
28 ga	3700 feet (1.1 km)

HydraSwing Wiring Chart (Incoming Power)

The maximum distance shown is from the operator to the power source, assuming that source power is from a panel box with adequate capacity to support the addition of this motor load. The values are for one operator, with no other loads applied to the branch circuit. Avoid placing more than one operator to a circuit, but if you must, be certain to reduce the maximum allowed wire distance by half.

NOTE: HydraSwing gate operators connected for 1Ø operation will draw more current because the utility power to run the machine will be carried to the operator on two wires instead of the three used for 3Ø operators. Be sure to allow for this difference when specifying wire size.

Make sure proper wiring is being used. The following table shows the maximum allowable wire run from the power source to the operator for various wire sizes. Performance of VFD operators on 1Ø and 3Ø 50/60 Hz Power.

NOTE: Distance shown in U.S. Standard "feet." Metric equivalent shown in parentheses.

HydraSwing VFD Wire Size Chart						
Phase Ø	1	1	3	3	3	3
Voltage	208	230	208	230	380	460
Horsepower	2	2	2	2	2	2
VFD Rating Amps	17.4	17.4	8.7	8.7	5.2	5.2
Wire Gauge	Distance	Distance	Distance	Distance	Distance	Distance
12	90 (27m)	100 (30m)	220 (67m)	240 (73m)	680 (207m)	830 (253m)
10	150 (46m)	170 (52m)	350 (107m)	390 (119m)	1090 (332m)	1310 (399m)
8	240 (73m)	270 (82m)	560 (171m)	620 (189m)	1730 (527m)	2100 (640m)
6	390 (119m)	430 (131m)	900 (274m)	990 (302m)	2750 (838m)	3330 (1015m)
4	620 (189m)	680 (207m)	1430 (436m)	1580 (482m)	4380 (1335m)	5300 (1615m)
2	990 (302m)	1090 (332m)	2280 (695m)	2530 (771m)	6990 (2130m)	8470 (2582m)

Performance of Operators on 1 and 3 Phase 50/60Hz

A HySecurity Variable Frequency Drive (VFD) operators can operate on a wide variety of incoming power.

- 50Hz/60Hz operation with no changes or reconnection
- 1Ø or 3Ø operation by field rewiring and reconnection. The incoming voltage must match the operator nameplate. Although the electric motor can be reconnected, a different VFD (motor controller inside the grey control box) is required between 460V and 208V/230V.
- Any AC powered peripherals such as locks, card readers and other devices need to be checked for compatibility.
- The electric motors in all variable frequency drive operators are 3Ø/60Hz motors and are connected for the voltage on the operator nameplate. (208V/230V or 460V)

How is this done?

- The VFD controller in the operator is rated to operate on input frequencies ranging from 48Hz through 62Hz on 1Ø or 3Ø power, but only on either 460VAC or 208V/230V. (A change between 460V and 230V, either direction, requires replacement of the VFD controller).
- The control transformer in the operator has multiple voltage taps and rated for 50/60Hz operation.
- The VFD controller first rectifies and filters the incoming power to DC, which has no frequency or phase. It then creates 3Ø variable voltage/variable frequency AC for the motor from the DC.
- Depending on the model, the VFD controller ramps the motor voltage and frequency from 0V@0Hz at start, to either 208/230 or 460 VAC at various frequencies for full speed. This allows use of 60Hz motors regardless of the incoming frequency.
- Since the input voltage/frequency is converted to DC to begin with, there is absolutely no relationship between the input frequency/phase and frequency/phase of the power supplied to the motor. The input could be 1Ø or 3Ø, 48Hz or 62Hz and the controller/motor combination wouldn't care. It will create the ramped 3Ø voltage and frequency for which it is programmed

In-Field Connections

HydraSwing operators are field re-connectable for 1Ø or 3Ø, 208/230VAC input power without changing the VFD.



HydraSwing operators CANNOT be connected to 115/120VAC, 1Ø power or 575V, 3Ø power. If any attempts are made to do so, serious injury, electrical shock, or death may result. Any electrical damage occurring to the operator will not be covered by the Limited Warranty.



HydraSwing operators are NOT field re-configurable between 208/230VAC and 460VAC power. The VFD Motor Controller in a 208/230VAC unit must be replaced with a VFD Motor Controller manufactured for the higher (460VAC) voltage input.

UPS BACKUP POWER OPTIONS

If you plan to use back up power options, additional site considerations are needed including conduit to house the hydraulic hoses and electrical wiring. You need a 2-inch (5 cm) diameter conduit for hydraulic hoses and a ¾-inch (19 mm) conduit for electrical wiring. Mounting locations such as pad mount or wall mount also need to be determined. See site planning overview in the installation instructions.

[Supplemental manuals](#), available online, describe the installation overview, wiring and conduit considerations.

AC Power Supply with HyInverter AC

Gate operators equipped with the AC Power Supply with HyInverter AC option are powered by four 12-Volt, 110Ah DC batteries which, when AC power loss occurs, maintain a true Uninterrupted Power Supply (UPS) system. When the local AC power fails, the UPS back up system continues to move the gate. System features are covered in the *HyInverterAC Installation and Reference Manual* shipped with the product and available online at www.hysecurity.com.

NOTICE: The AC Power Supply with HyInverter AC option is intended for single phase (1 hp) gate operators and single phase (2 hp) gate operators that use Variable Speed Drives (VFD).

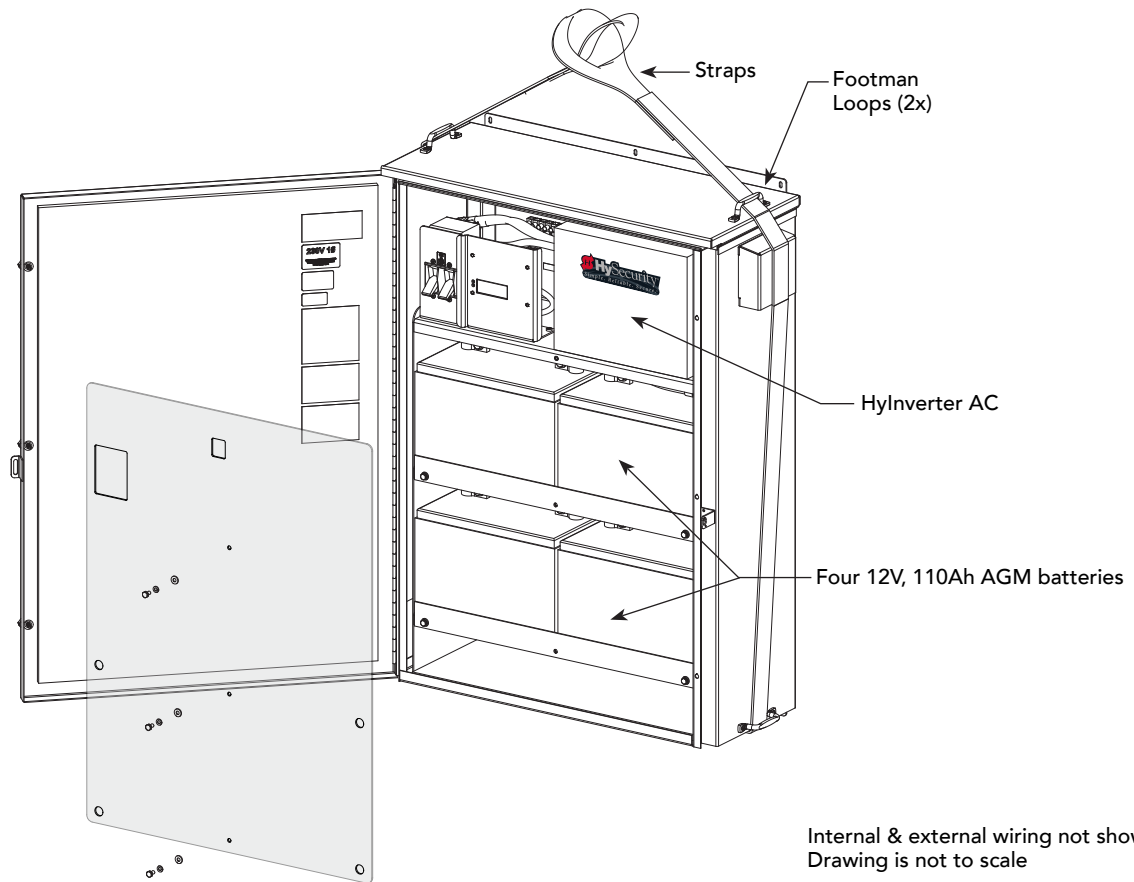

Initial Setup

When you first apply power to the operator, it is locked in Menu mode and prompts appear on the display. The gate will not move and the controls will not function until the prompts have been answered. The prompts include:

- Usage Class setting
- Open Position setting (refers to the cylinder's position when the gate is open: Retracted or Extended)
- Three external entrapment protection SENSOR requirements.



Before turning the power switch to ON, be sure to replace the vent cap with the breather cap. Refer to page 17. Make sure all site requirements concerning proper wiring, safety, foundation installation, and electrical power have been met.

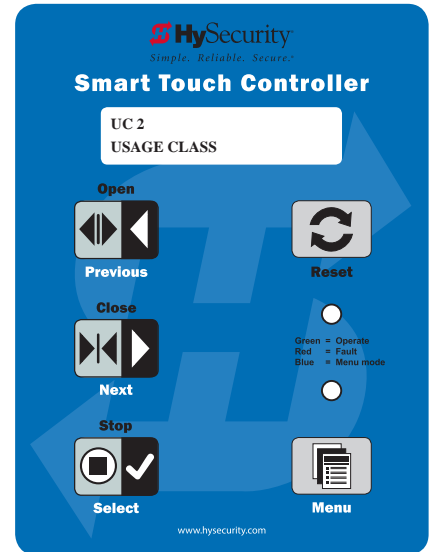

Five buttons on the display keypad provide operational controls. Refer to *Display and Menu Options* for more information. To answer the initial prompts, use the Previous, Next, and Select buttons as described in the chart below:

Smart Touch Controller: Menu Mode Navigation Buttons

To change that data appearing in the display	To navigate through the Selections	To choose what appears on the display	To navigate between menu items
Press Select . Two left characters blink.	Press Next . Continue pressing Next to view all selections. (Press Previous to reverse direction.)	Press Select . Blinking characters become static.	Press Next or Previous . Advance - press Next Previous - press Previous

If you are unsure of the usage classification, refer to *Identifying Gate Operator Category and Usage Class* under "IMPORTANT SAFETY INFORMATION" on page 17. It explains the different usage site classifications for UL 325.

OPEN POSITION AND HYDRAULIC HOSE SWAP

Open Position is determined by viewing the gate opening from the secure side. If the cylinder retracts to open the gate, set the Open Position to "R." If it extends, select "E."

- Select OP "R" or "E" when prompted

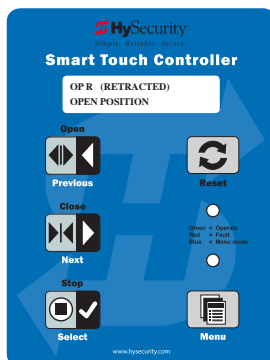

- If OP is assigned "E" for extended, and the gate swings out, swap position of the hydraulic hoses.

Swap hoses if motor engages and gate moves in the wrong direction

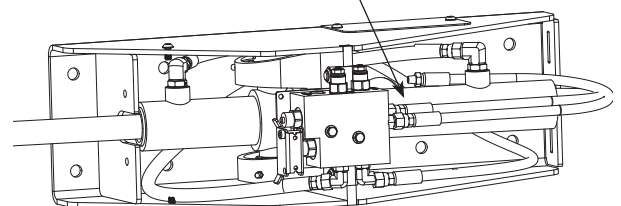

GATE POSITION SENSOR

An absolute position sensor is enclosed within the cylinder housing so the maintenance of physical limit switches is eliminated and the durability of the operator is enhanced. The Smart Touch Controller is able to constantly monitor the gate position. The Learn Close Limit display appears when power is initially supplied to the operator.

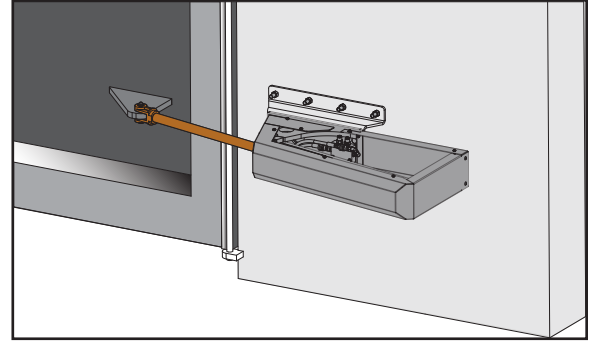

When set, position sensing remains intact even if power is lost. The only exceptions occur when factory defaults are reinstated, or the Smart Touch Controller is replaced.

SETTING THE CLOSE & OPEN LIMITS

Programming the limit settings is usually a one-time occurrence. The Reset and Program buttons do not function while the operator is learning its limits. More information about relearning limits is found in Learn Limit Reset in the Installer Menu. Refer to *Table 6: Installer Menu* in Display and Menu Options section.

To establish the open and close limits, follow the steps in the chart below, and then cycle the gate a few times.

<p style="text-align: center;">LEARN CLOSE INCHES: - XXX.X</p>	<p>Learn Close Limits</p> <p>Choose one of the following bullet procedures depending on the gate location.</p> <ul style="list-style-type: none"> • The gate is in the desired closed position – press Stop twice. The buzzer chirps twice and the full close stop is retained in memory. • The gate is not in the desired closed position - press and hold the Close button until the gate moves to full close. (Flashing numbers decrease while the gate is closing.) If you need to reverse the angle of the closed gate, press and hold Open to for a second or two. Release the button. To retain the closed position press Stop twice. The buzzer chirps twice and the full close stop setting is retained in memory.
<p style="text-align: center;">LEARN OPEN INCHES: + XXX.X</p>	<p>Learn Open Limits</p> <p>Press and hold the Open button until the gate reaches the open position you desire. Release the Open button. If the gate needs adjustment, you can press and hold Close to reverse direction.</p> <p>Press Stop twice to preserve the open stop location in memory. The buzzer chirps twice and the full open stop setting is retained in memory.</p>

To reset the close and open limits, refer to page 62.

ADJUSTING THE PRESSURE RELIEF VALVE

When placing the operator into service, pressure relief valve adjustments are required! To provide instruction during installation, a cautionary yellow tag is wire tied to every pump pack. The same instructions are provided in this section.

Pressure relief valves differ depending on the model.

Tools Needed: ½" and ⅝" box end wrenches.

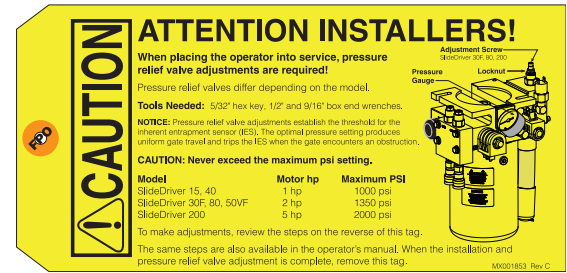

NOTICE: Pressure relief valve adjustments establish the threshold for the inherent entrapment sensor (IES). The optimal pressure setting produces uniform gate travel and trips the IES when the gate encounters an obstruction.

Model #	Model	Gallons per Minute	Motor hp	Maximum PSI
1	HydraSwing 150	3.1	2 hp	1200 psi
2	HydraSwing 80F	4.0	2 hp	1200 psi
3	HydraSwing 40 and 40 Twin	0.8 and 1.6	2 hp	1200 psi
4	HydraSwing 40F	1.2	2 hp	1200 psi



Never exceed the maximum psi setting.

Make sure the gate is properly installed and aligned before performing the following steps. Take precautionary measures to keep the gate's travel path clear. The gate will be moving while you adjust the pressure relief valve.



DO NOT attempt to adjust the pressure relief valve unless you are an experienced hydraulic gate operator installer. Incorrect pressure settings can cause injury and even death!

1. Expose several threads on the Pressure Relief Valve by loosening the locknut with a ⅝" box end wrench.
2. Use a ½" box end wrench to turn the Adjustment Screw.
3. Use the keypad to cycle the gate Open or Close and, while the motor is running, turn the Adjustment Screw clockwise (CW) to raise the pressure. The motor runs for a few seconds, stops, and then enters safe mode. SAFE appears on the display.
4. Press Reset and repeat step 3 until gate travel is reliably consistent without entering SAFE mode.
5. To lock in the pressure setting, hold the Adjustment Screw with or wrench and tighten the locknut.

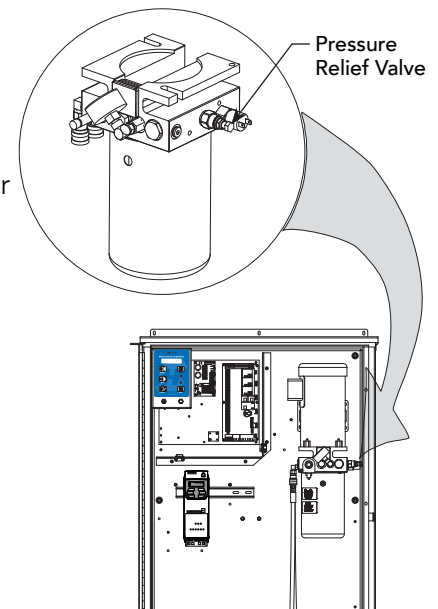

MODBUS RTU IN HYDRASWING

In the HydraSwing™, a communication protocol allows the Smart Touch Controller to constantly monitor the Variable Frequency Drive (VFD) and record events in the STC history log. The history log is easily accessible using the HySecurity S.T.A.R.T. program and a PC laptop computer or view history log codes by accessing the User Menu, LG item (software version h5.53 or later).

With the ModBus RTU:

- Reduction in field calls is likely because the STC resets VFD faults or error codes upon receiving a new command.
- Quality issues with the site power are controlled better which results in less intermittent operator problems.
- Smoother operator acceleration and deceleration enhances gate travel.

All HydraSwing gate operators include ModBus cable and RTU communication protocol installed.

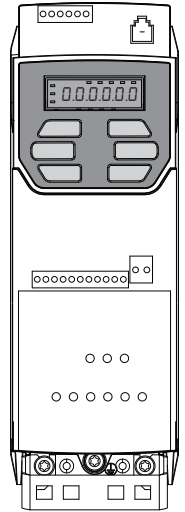

ADJUSTING THE GATE SPEED

The gate speed designates how quickly the gate opens and closes. The available range from 1 to 3 varies the speed of the motor and the gate speed increases as you go up the number scale.

Two displays, one for OPEN SPEED the other for CLOSE SPEED, exist in the Smart Touch Controller. The steps involved in changing the open speed are shown below. The steps to set the close speed are the same, you just need to access at the CLOSE SPEED display. The factory defaults for both are set to 2, a mid-range setting.

1. Start at the gate status display.
2. Access the user menu by pressing the Menu button twice.
3. Access the Installer menu, by simultaneously pressing the Open and Reset buttons.
4. Use Next to navigate to the menu display. Change the setting using the Select and Next buttons.

To exit the Installer menu, press the Menu button. The gate status appears in the display indicating you have returned to Run mode.

EMERGENCY FAST OPERATE (EFO)

Setting the Emergency Fast Close

To enable the Emergency Fast Close option on a HydraSwing operator, you need to program the Smart Touch Controller by taking the following steps:

NOTE: When you are in programming mode the buttons on the keypad change from Open, Close, and Stop to Previous, Next, and Select. Refer to *Menu Mode Navigation* on page 47.

1. Make sure the operator is turned ON and a Run mode status (ex., GATE OPEN) appears on the Smart Touch Controller, which indicates the machine is operational.
2. Press the Menu button twice to access the User Menu.
3. Press and hold the Reset button and then the Open button. Hold the buttons for two seconds and then release both buttons to access the Installer Menu.
4. Press Next until the Emergency Close OC 0 appears on the display.
5. Press Select and OC starts blinking, which indicates the display can be changed.
6. Press Next or Previous to change the display to OC 1.
7. Press Select to accept the entry. (The display characters stop blinking.)
8. Press Program to exit programming mode and return to Run mode. A Run mode gate status appears (ex., GATE OPEN).

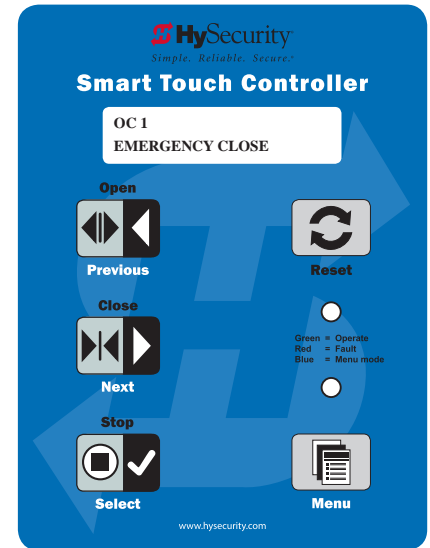

Installing a Push-Button Device for EFC

The Emergency Fast Close is designed for a constant hold function, such as a push-button device that is held for the duration of gate travel. To operate properly, a device must be connected between Terminal 23 on the Smart Touch Controller and a +24VDC terminal on the Power Module.

When the connections are made, a constant hold signal transmitted to the Smart Touch Controller causes the Emergency Fast Close function to close the gate at a higher speed than usual, and photo eyes, vehicle loop inputs, and other safety devices are ignored.

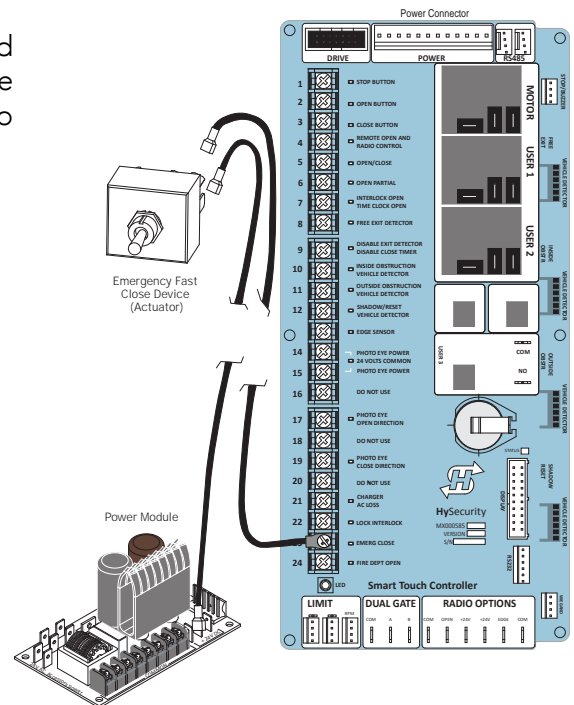

Entrapment Protection

As of January 2016, UL325 standard requires gate operators to monitor the presence of all external entrapment sensors, including non-contact (Photo Eyes) and contact (Edge) sensors. For operators built between January 1st, 2016 and July 31st, 2018 only one external entrapment sensor is needed to allow automatic operation, but all potential entrapment zones must be protected or eliminated. After July 31st, 2018, all Slide gate operators will need a minimum of 2 external entrapment sensors (1 open direction and 1 close direction) installed before automatic operation is allowed, but all potential entrapment zones must be protected or eliminated.

HySecurity monitors all external entrapment sensors connections by looking for NC contacts connected to input terminals. Smart touch software cycles power to device and looks for a time delay from when device powers on to when the contact closes (sensor input pulled low, meaning the sensor is not blocked/tripped).

Three programmable sensor inputs are available for use and must be programmed to a non-zero number when initial configuration is performed. The three inputs are labeled Sensor 1, Sensor 2, and Sensor 3 and are configurable in the installer menu (S1, S2, or S3) for the following options:

- 1 – Not Used
- 2 – Eye Close
- 3 – Edge Close
- 4 – Eye Open
- 5 – Edge Open
- 6 – Edge Both (Swing Only)
- 7 – Eye Both (Solo Slide Only)

It is the installers responsibility to determine the number of potential entrapment zones that exist and program the Sensor inputs according to which type of external entrapment sensor will be used to protect each zone. If more than three potential entrapment zones exist, then site design may be adjusted to eliminate risks or a Miller Edge MIM- 62 may be used to connect additional sensors.

Potential entrapment zones on a hydraswing gate are shown below. Included in the drawing are examples of potential external entrapment sensor mounting/installation locations.

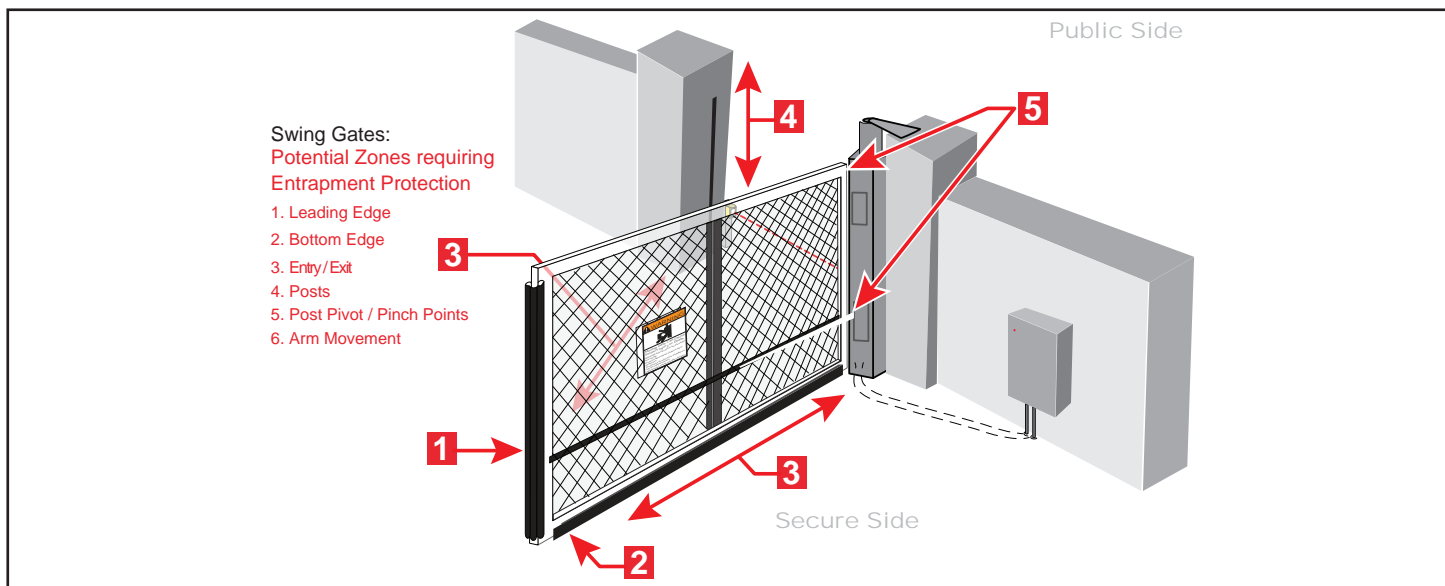

After programming the sensor inputs in the installer menu or during initial startup, the appropriate type and number of sensors will need to be connected. Figure 67 below shows the wiring and dip switch settings of an EMX-MON photo eye (typical thru-beam wiring). A retroreflective photo eye will be similar and only have wiring similar to the receiver of the thru-beam photo eye.

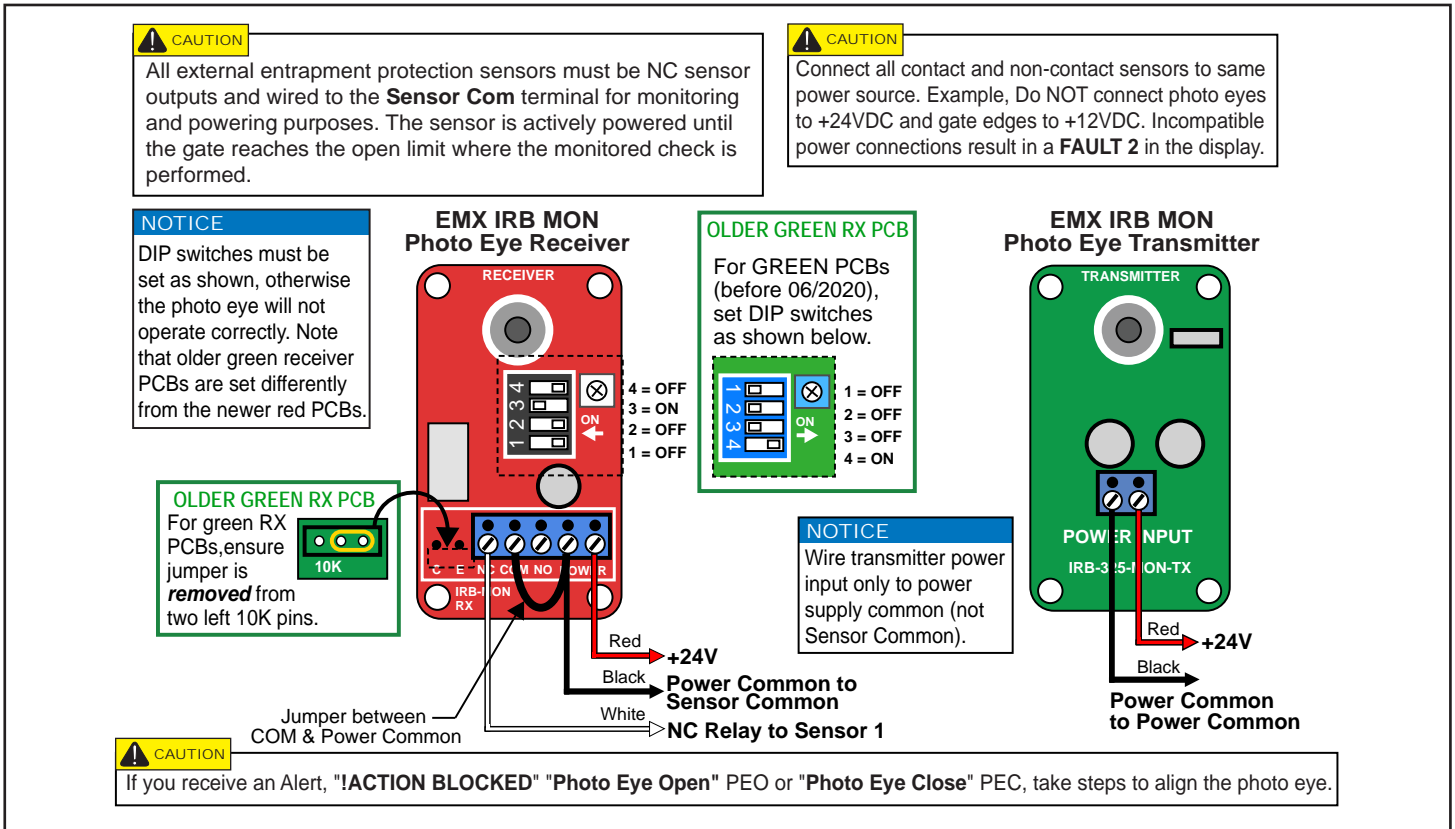

An Edge Sensor can be either hardwired through an adapter module (Hy2NC) or a wireless transmitter receiver combo (WEL-200 or iGAZE RE). Figure 68 below shows the wiring and dip switch settings of a WEL-200. For more information and wiring diagrams of other recommended sensors see the "HySecurity External Entrapment Sensor Wiring Guide".

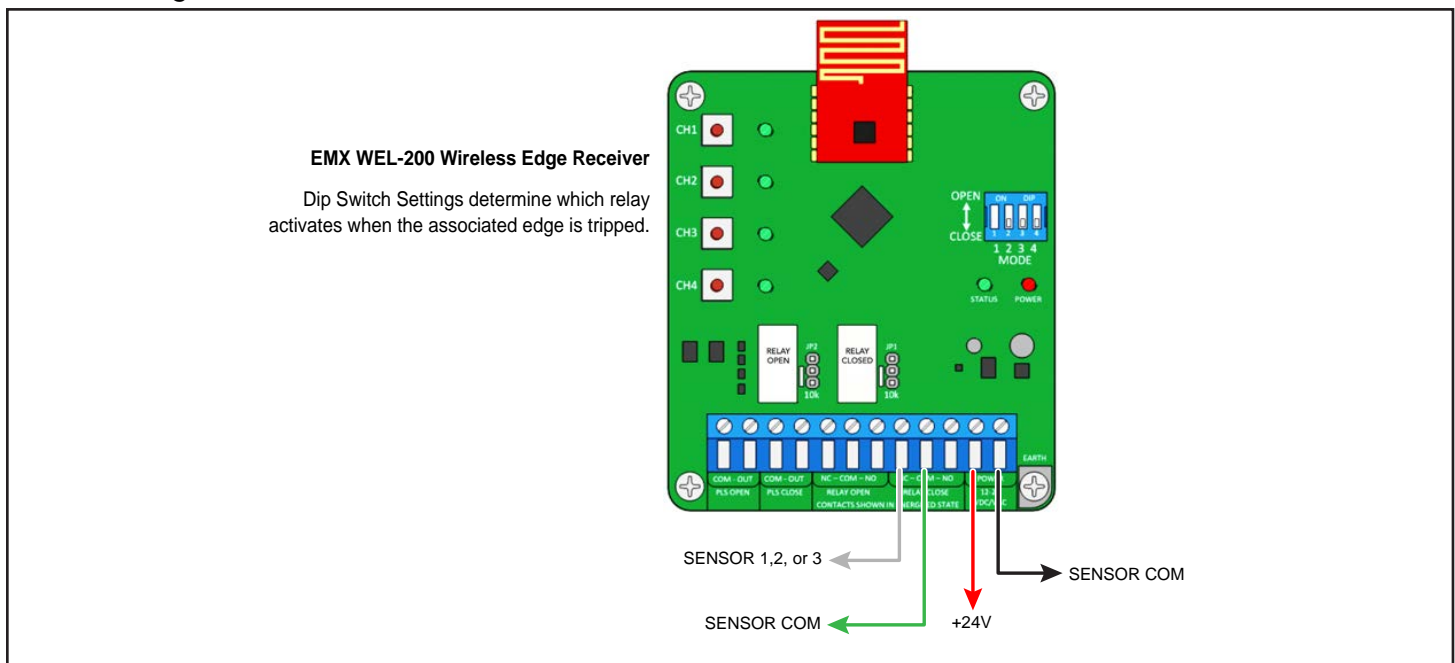

MANUFACTURER'S RESPONSIBILITY

- Build into the gate operator a means of detecting an obstruction or an inherent entrapment detection sensor
- Monitor input from external entrapment detection sensors
- Provide warning signs and an installation manual which, if followed, will result in a UL 325 compliant installation

Pressure Relief Valve – All Hydraulic Operators:

- Limits hydraulic system pressure
- Bypasses fluid to tank when set-point exceeded
- Bypassed fluid triggers the IES

NOTICE: Pressure relief valve adjustments establish the threshold for the Inherent Entrapment Sensor (IES). The optimal pressure setting produces uniform gate travel and trips the IES when the gate encounters an obstruction.

Inherent Entrapment Sensor System – Hydraulic Operators (IES)

The IES sensor:

- Is a normally closed pressure switch on the pump manifold
- Senses fluid flow. High pressure spikes above pressure relief valve setting trigger gate obstruction notification
- Ignores first second of operation to preclude false trips due to starting pressure spike

An open contact:

- During gate movement signals the Smart Touch Controller to place gate operator into SAFE mode
- While the gate is not operating will generate ERROR 2 (ERR2) - disconnected IES

NOTE: A second open contact, in either direction of travel, will lock the gate operator and ENTRAPMENT MODE (ENTR) appears on the display.

THE INHERENT ENTRAPMENT SENSOR (IES)

The IES on HySecurity gate operators is an entrapment sensor that is required by UL 325 as a Type “A” detection sensor. It is tripped through software programming OR hydraulic pressure settings. It does not function solely on its own accord and must be connected to the Smart Touch Controller. The sensitivity and response of the IES when tripped is factory set, but can be adjusted through the Installer Menu items:

- SE (Inherent Sensor sensitivity)
- SS (Inherent Sensor function)
- SR (IES reverse to open)

Smart Touch Controller™ – Installer Menu Functions for IES		
Installer Menu Display Code	Setting Options (Bold – Factory Settings)	Description
SE 2 IES SENSITIVITY	1 = max. sensitivity 2 = Default setting 9 = least sensitivity	Adjusts the sensitivity of the internal inherent entrapment sensor (IES). Available settings are 1 to 9 with 9 being the least sensitive. HySecurity strongly recommends that you avoid setting the IES sensitivity higher than 6. Note: Adjust pressure relief valve on hydraulic operators for security and gate impact purposes prior to changing IES sensitivity. Refer to the operator’s manual for steps involved in adjusting the pressure relief valve setting.
SS 0 (OFF) IES STOP ONLY	0 = stop, reverse for 2s 1 = stop only	A setting of 0, stops the gate and then reverses its direction of travel for 2 seconds. To stop gate travel with no reversal, the optional setting 1 can be selected if the gate operator is at a Usage Class IV site and assigned a UC 4 classification.
SR 0 (FULL OPEN) REVERSAL LOGIC	0 = IES reverses fully open 1 = Two second reversal only	Setting of SR 0 causes the gate to reopen fully if triggered while closing. With a setting of 1, if the inherent sensor is triggered, the default setting reverses the gate travel for a 2-second duration.

HOW SOFTWARE HANDLES MONITORING EXTERNAL ENTRAPMENT PROTECTION SENSORS

HySecurity gate operators use software to control gate movement, contacts, and accessories. The changeover in 2016 to monitoring sensors has been a simple process.

- Build Year is a new Installer Menu item in the Smart Touch Controllers versions h4.50 (and higher).
- New labels show where Edge, Photo Eye Open and Photo Eye Closed have changed to “SENSOR” inputs. You can program the type of sensor wired to each of those inputs. See table below.
- Installer Menu items, PC and GC (Photo eye output and edge sensor output) which used to default to Normally Open (NO) have been converted to Normally Closed (NC) contacts so the software can detect the presence and proper operation of external entrapment protection sensors.

Table 3: Changes to Sensor Inputs on the Controller

Location of Sensor Inputs on Controller			Installer Menu Item Codes	
Smart Touch Controller (STC): Hydraulic gate operators			Smart Touch Display:	
Input #	Current Silk Screen Label	2016 Silk Screen Label	OLED - two line, 32 character	LCD - 7 segment text
13	EDGE SENSOR	SENSOR 1	S1 SENSOR 1	51
17	PHOTO EYE OPEN DIRECTION	SENSOR 2	S2 SENSOR 2	52
19	PHOTO EYE CLOSE DIRECTION	SENSOR 3	S3 SENSOR 3	53

NOTE: Three inputs for external entrapment protection sensors are available on the HySecurity gate operator controller.

Table 3 indicates how the edge and photo eye inputs have been renamed to generic “sensor” inputs. They are interchangeable and configurable. The software must know what type of sensor is wired to SENSOR 1, 2, and 3 **BEFORE** it will allow gate travel.

EXTERNAL ENTRAPMENT PROTECTION SENSORS: WHAT THE INSTALLER NEEDS TO DO

NOTE: All HySecurity gate operators, built after 2016, will have the Build Year setting.

A Build Year of 2 or 3 (BY 2 or BY 3) indicates that your gate operator is prepared to monitor for external entrapment protection sensors. The Build Year setting appears in the system scroll on the gate operator display. BY 2 is for operators built between January 1, 2016 and July 31, 2018. BY 3 is for operators built after July 31, 2018. **The gate operator will not automatically cycle the gate unless an indication that the appropriate number of external entrapment protection sensors are connected and operational.**

The normally closed (NC) entrapment protection sensors wired to the Controller’s SENSOR inputs are monitored using HySecurity software. Prompts appear in the display requesting specific configurations based on the gate operator type.

Table 4: *Installer Menu Options for SENSOR Inputs* illustrates what options are available for the HySecurity Controller’s configurable inputs. Inputs labeling changed to:

SENSOR 1 SENSOR 2 SENSOR 3 SENSOR COM

Refer to illustration on page 43.



All external entrapment protection sensors must be wired to the SENSOR COM terminal for power and monitoring purposes. Depending on software version the sensor becomes actively powered when the gate operator receives a run command, or is always powered when AC power is present. Either way, the sensors are checked for presence at least once per cycle. The three SENSOR inputs are interchangeable and configurable. For example, it doesn't matter whether you wire a normally closed photo eye sensor or edge sensor to the SENSOR 1, 2, or 3 input. However, due to monitoring requirements, each SENSOR input (1, 2, and 3) can only accept one NC sensor output connection.

1 Assess Your Gate Site.

Design your gate installation so entrapment zones are kept to a minimum, and then install your HySecurity gate operator.

NOTICE: UL 325 Standard of Safety provides the MINIMUM safety standards. Site, gate hardware usage, and other conditions may dictate the use of additional safety designs/components. It is up to the gate system designer and installer to assess appropriate safety design and components above and beyond minimum UL 325 and ASTM F2200 standards. Always check your local area codes and comply with all regulations.

Swing Gates:

Potential Zones requiring Entrapment Protection

1. Leading Edge
2. Bottom Edge
3. Entry / Exit
4. Posts
5. Post Pivot / Pinch Points
6. Arm Movement

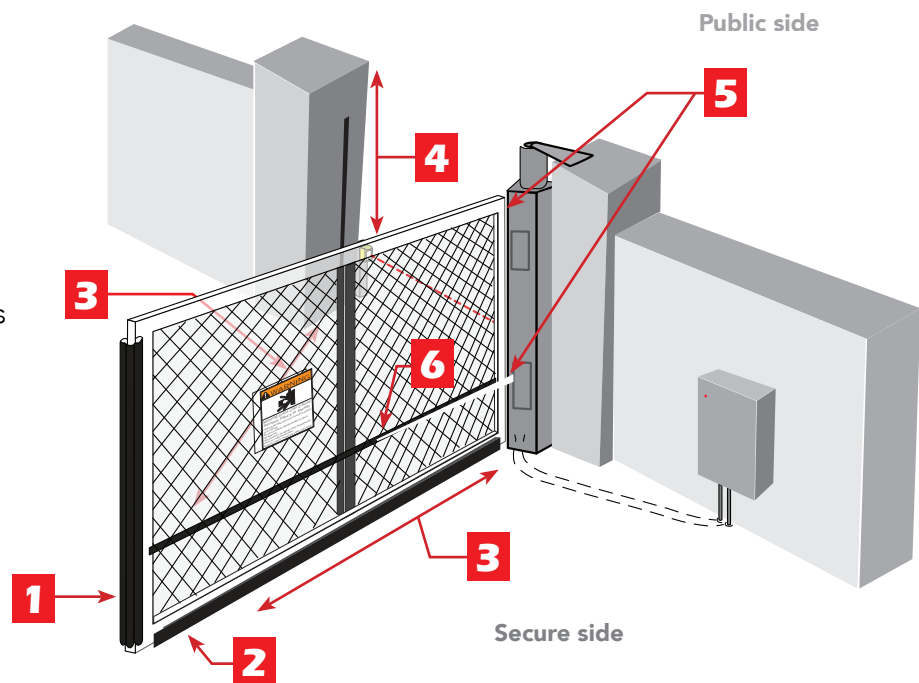

NOTE: SwingRiser shown for reference only. HydraSwing zones are similar.

Drawing NOT TO SCALE

2 Install NC sensors.

Install contact and non-contact sensors (edge sensors and photo eyes) for all entrapment zones. HySecurity gates monitor normally closed (NC) sensors. Wire your NC sensors to SENSOR input terminals (SENSOR 1, SENSOR 2, or SENSOR 3) on the Smart Touch Controller.

NOTE: When installing wired edge sensors, the WIRED EDGE must be connected to an interface module that produces an NC output. Refer to *Wiring HySecurity Sensors: Smart Touch* on page 129. However, wireless edge sensors, require no interface module. Wireless edge sensors need the wireless gate links which include a transmitter and receiver.

3 Turn Power ON.

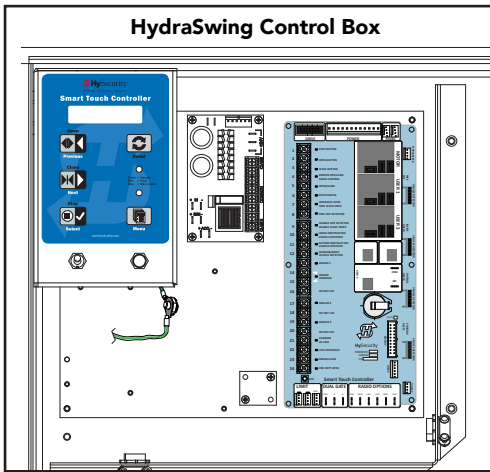

NOTE: On the next page, review LED function and how to provide temporary power to the sensors.

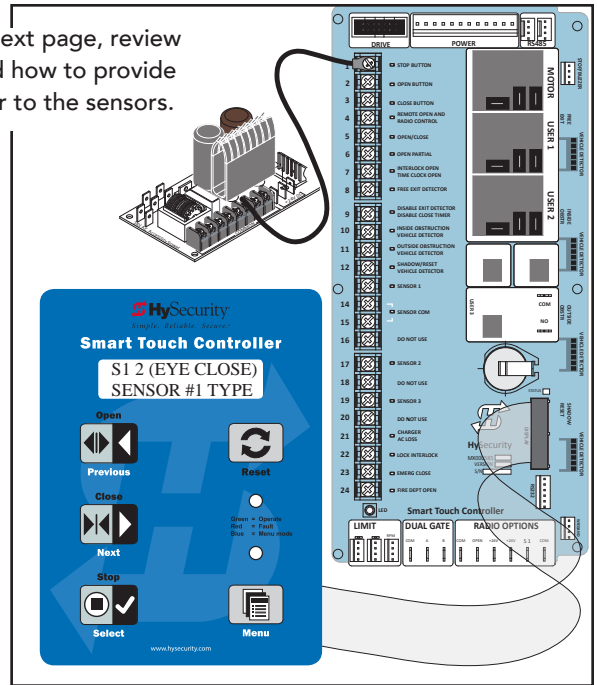

4 Answer Initial Setup Prompts.

Initial setup prompts appear and need to be addressed before your gate will move. Each SENSOR input, whether or not it has a contact or non-contact sensor wired to it, must be programmed to a non-zero setting before the gate will move.

NOTE: The gate operator will not automatically cycle unless an indication is received that the appropriate number of external entrapment protection sensors are connected and operational. At minimum, external entrapment protection sensors must be used to protect either the open or close directions of swing gate travel as long as their is no risk of entrapment in the other direction of a swing gate. For Slide gates, both open and close direction must have an external entrapment sensor.

Smart Touch and Smart DC Controller: Menu Mode Navigation Buttons

To change data appearing in the display	To navigate through the Selections	To choose what appears on the display	To navigate between menu items
Press Select . Two left characters blink.	Press Next or Previous . Continue pressing Next to view all selections.	Press Select . Blinking characters become static.	Press Next or Previous . Advance - press Next Previous - press Previous

Table 4: Installer Menu Options for SENSOR Inputs

UL 325 HySecurity Gate Operator	Build Year 2016 (BY set)	Installer Menu Settings for STC & SDC Sensors 1, 2, or 3 (solo operators)							
		#0 DISABLED	#1 NOT USED	#2 EYE CLOSE	#3 EDGE CLOSE	#4 EYE OPEN	#5 EDGE OPEN	#6 EDGE BOTH DIRECTIONS	#7 EYE BOTH DIRECTIONS
SlideDriver (fixed speed)	2	●	●	●	●	●	●		●
SlideDriver VFD	2	●	●	●	●	●	●		●
SlideSmart DC 15	2	●	●	●	●	●	●		●
SlideSmart DC 10	2	●	●	●	●	●	●		●
SwingRiser	2	●	●	●	●	●	●	●	
SwingSmart DC	2	●	●	●	●	●	●	●	
HydraSwing	2	●	●	●	●	●	●	●	
HydraLift	2	●	●	●					

NOTE: HySecurity does not update software for SlideWinder models. For information regarding HySecurity gate operators not shown in the table above, refer to Table 1 under "IMPORTANT SAFETY INFORMATION" on page 19.

SUPPLY POWER TO THE SENSORS



All external entrapment protection sensors must be wired to the SENSOR COM terminal for monitoring purposes.



Review sensor wiring diagrams found in *Wiring HySecurity Sensors: Smart Touch* on page 129.

Until the gate operator receives a command to run (open or close command), the sensors are not receiving power (pre-h4.56 and h5.57 software). However, to **temporarily** power sensors and check that the gate operator is monitoring the sensors properly, turn on Photo Eye Align mode.

To turn on Photo Eye Align mode, take the following steps:

1. Access the User Menu and select PE. (Press the Menu button twice to access the User Menu. See chart on the previous page.)
2. Press NEXT and continue to press NEXT until PE 0 (OFF) appears.
3. Press SELECT.
PE characters begin blinking.
4. To turn ON photo eye alignment and temporarily power the sensors, press NEXT so PE 1 (ON) appears.
5. Press SELECT.
PE stops blinking.
6. Press MENU to exit Menu Mode and return to Run Mode.

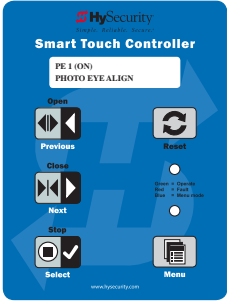
NOTE: The Photo Eye Align mode turns OFF with the next limit contact. For more information, refer to *Photo Eye Alignment Feature* on page 102.

Controller	Temporarily apply Power to Sensors	LED Status
<p>Smart Touch (Hydraulic gate operators)</p>	<p>PE 1 (ON) PHOTO EYE ALIGN</p> 	<p>LEDs next to the sensor connections will be lit when no power is being applied. When PE is turned ON, the LEDs turn off. If they do not turn off, check for wiring issues such as a short or misapplied relay COM connections. See CAUTION on page 40.</p>
<p>Smart DC (electromechanical gate operators)</p>	<p>PE 1 (ON) PHOTO EYE ALIGN</p> 	<p>When PE is ON, the LEDs associated with the sensor devices will be lit if the sensors are properly connected and sensors are grounded. The LEDs turn off when the ground circuit is removed.</p>

Control Panel Overview

This section provides an overview of the electrical controls found in your gate operator. The illustrations highlight the various components and describe their function. Each call out explains where to find more information about the component.

STC Display & Keypad:

Provides push button programming and displays menu codes, faults, alerts & errors. Refer to *Display & Menu Options* on page 44.

Power Disconnect Switch

Provides ports for incoming power and feeds to the VFD. For more information, refer to *Wiring AC Power* on page 21.

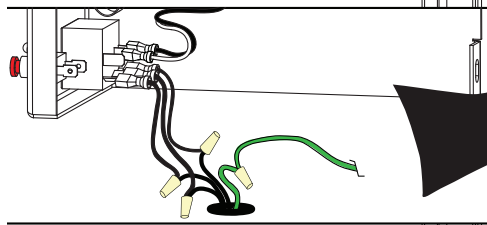

CAUTION

Make sure the connection wires match the voltage label found on the operator's name plate.

NOTE: Refer to *Wiring Diagram: HydraSwing/HydraSupply* on page 23.

Power Supply

Provides common and 24VAC & 24VDC terminals. Refer to *Overview of the STC and Power Supply Board* on page 66.

Smart Touch Controller:

Provides inputs for peripherals & accessories, 2 electromechanical user relays (250VAC, 10A), one solid state user relay (30VDC, 3A). For more information, refer to *Overview of the STC and Power Supply Board* on page 66. Hy8Relay option provides eight additional user relays.

Variable Frequency Drive

(VFD): Controls RPM for smooth acceleration & deceleration and connects to the STC through ModBus communication wires for diagnostic purposes and control handling.

CAUTION

Residual voltage remains in the VFD which can cause electrical shock to personnel or damage to the equipment.

← **Earth Ground**

STC BOARD, POWER SUPPLY BOARD AND DISPLAY

The Smart Touch Controller provides connections for a multitude of peripherals and accessory devices. The Power Supply Board offers 8 common bus terminals, 4 terminals (24VAC) and 3 terminals (24VDC) with a 3A maximum draw. The touch-sensitive keypad and 32-character display connects to the STC with a waterproof ribbon cable. For more information about STC Inputs and connections, refer to *STC Inputs & Wiring* on page 65. For more information about the display programming, operator modes and keypad navigation, refer to *Understanding the Display and Keypad* on page 44.

Smart Touch Controller:
Provides inputs for peripherals & accessories, 2 electro-mechanical user relays (250VAC, 10A), one solid state user relay (30VDC, 3A). For more information, refer to *STC Inputs & Wiring* on page 65.

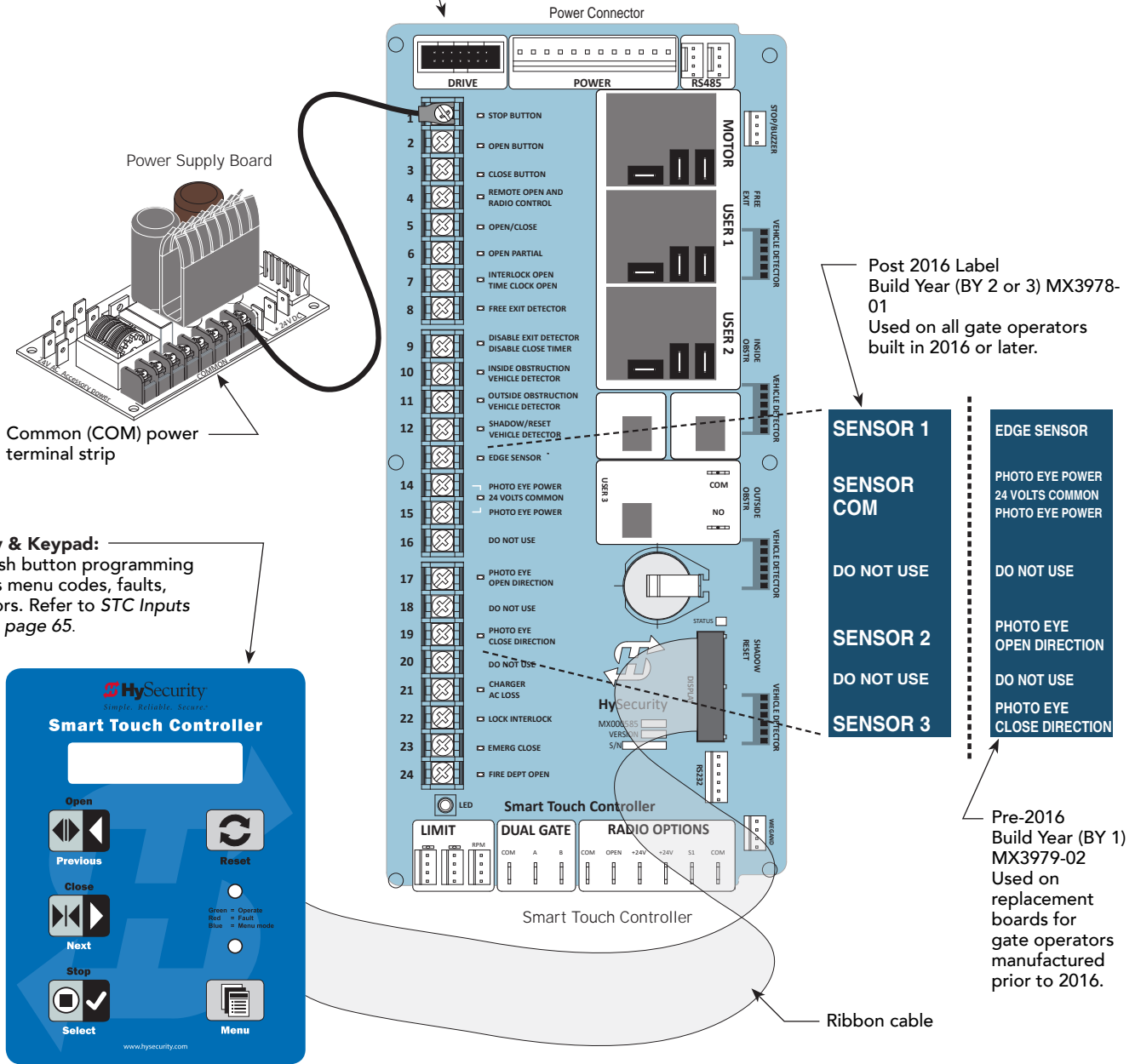

Display & Menu Options

Highly sophisticated software provides three different modes of operation: *run*, *program*, and *fault*. How to navigate using the Smart Touch Controller (STC) keypad, interpret status display codes and program the operator is found in this section.



Keep your operator current with the latest software version. If your gate operator was manufactured in 2016 (or later), it must monitor external entrapment protection sensors to be compliant with UL 325 - 2016 Standard of Safety.

UNDERSTANDING THE DISPLAY AND KEYPAD

All system settings are performed using just four programming buttons and an easy-to-read 32 character display (OLED). RS-232 and RS-485 ports provide connections for external communication. A real time clock and an EEPROM logs events.

The STC display and keypad provide access to the operator's sophisticated software and functionality.

Three different operational modes exist:

- Run Mode – gate is operational, awaiting commands.
- Menu Mode – motor disengages and operator commands are ignored. Data entry, menu navigation, and menu selection can be accomplished via the keypad or through a START software connection using the RS-232 port.
- Fault Mode – alerts, faults, or errors appear on the display. Some errors or faults can be reset with the Reset button while more serious faults require additional troubleshooting. Fault mode indicates a need for diagnosis and resolution. Refer to *Troubleshooting* on page 106.

The keypad lets you navigate, change, or clear the information in the display menus. The singular use of these keys is dependent on the operator mode. The buttons with text above and below have two functions. Use these buttons to enter operating commands or navigate through the User and Installer Menus.

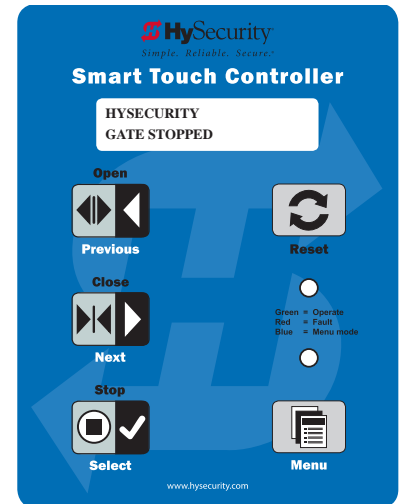

Gate Status Display in Run Mode

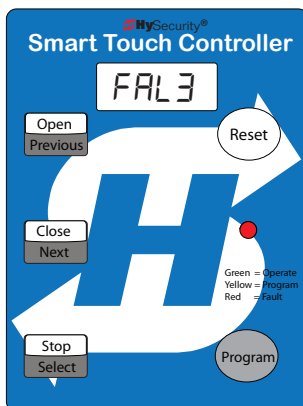

Smart Touch Display/Keypad, pre 2014

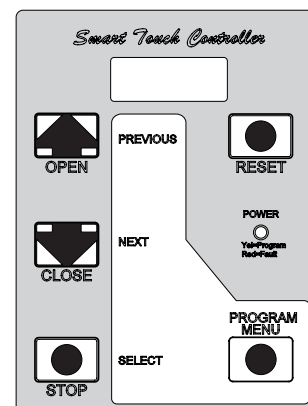

Smart Touch Display/Keypad, pre 2009

INITIAL SETUP

Once you have completed the installation of the HySecurity operator and attached the wired accessories, you're ready to program the operator. Two different approaches exist:

- Connect a laptop computer to the serial RS-232 connector and set the operator menu configurations via the S.T.A.R.T. software. Refer to the [START User Guide](#).

NOTICE: Use a laptop computer at your place of business to conveniently download the free START software from www.hysecurity.com before heading out into the field. This makes it easy to adjust and configure operator settings using a laptop in the field.

- Manually navigate through the User and Installer Menus using the four Menu Mode buttons located on the Smart Touch Controller Keypad. The instructions for performing this second option are provided in this section.

After installing a new operator, an initial sequence of set up prompts appears when you first turn ON the Control Box power switch. You need to answer the prompts before the gate operator will run. The operator is in "MENU" mode.

For example:

In the HydraSwing operator, you must set usage class and address 3 sensor inputs.

UC = **Usage Class**. Set the usage class to 1, 2, 3, or 4 depending on the site.

Four different vehicular usage classes are defined by UL 325.

Information about the classes can be found online through DASMA Technical Data Sheets www.dasma.com or UL 325 www.ul.com

OP = Open Position. E = Extended cylinder and R = Retracted cylinder. Refer to *Open Position and Hydraulic Hose Swap* on page 29.

S1, S2, and S3 = Contact and non-contact external entrapment protection sensor inputs that require monitoring per installation site and UL 325 Standard of Safety requirements.

Power switch on a HydraSwing control box

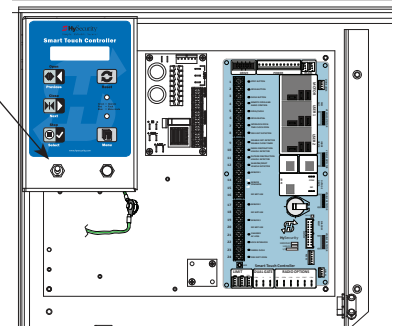

Selection: Usage Class
Select between: 1,2,3, or 4

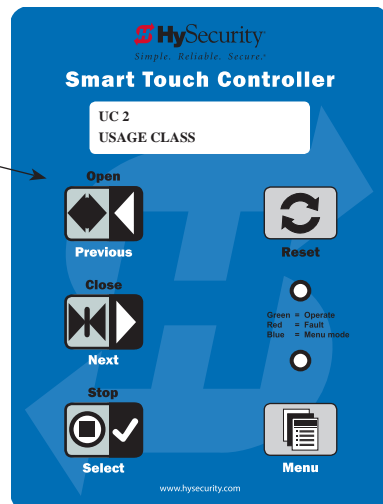

SENSOR settings required

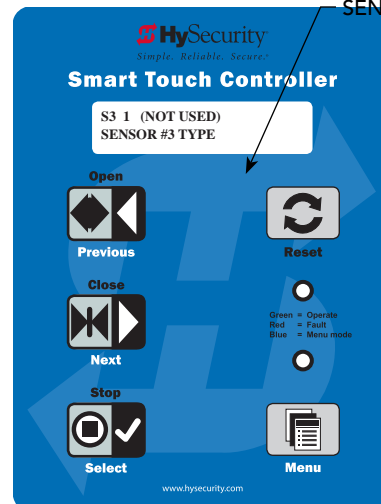

MENU MODE AND THE STC KEYPAD

In Menu Mode, the motor disengages and operator commands are ignored. Data entry, menu navigation, and menu selection can be accomplished using the buttons on the Smart Touch Controller keypad.

NOTE: Menu Mode automatically returns to Run Mode if no activity (i.e. key presses) occurs for two minutes.

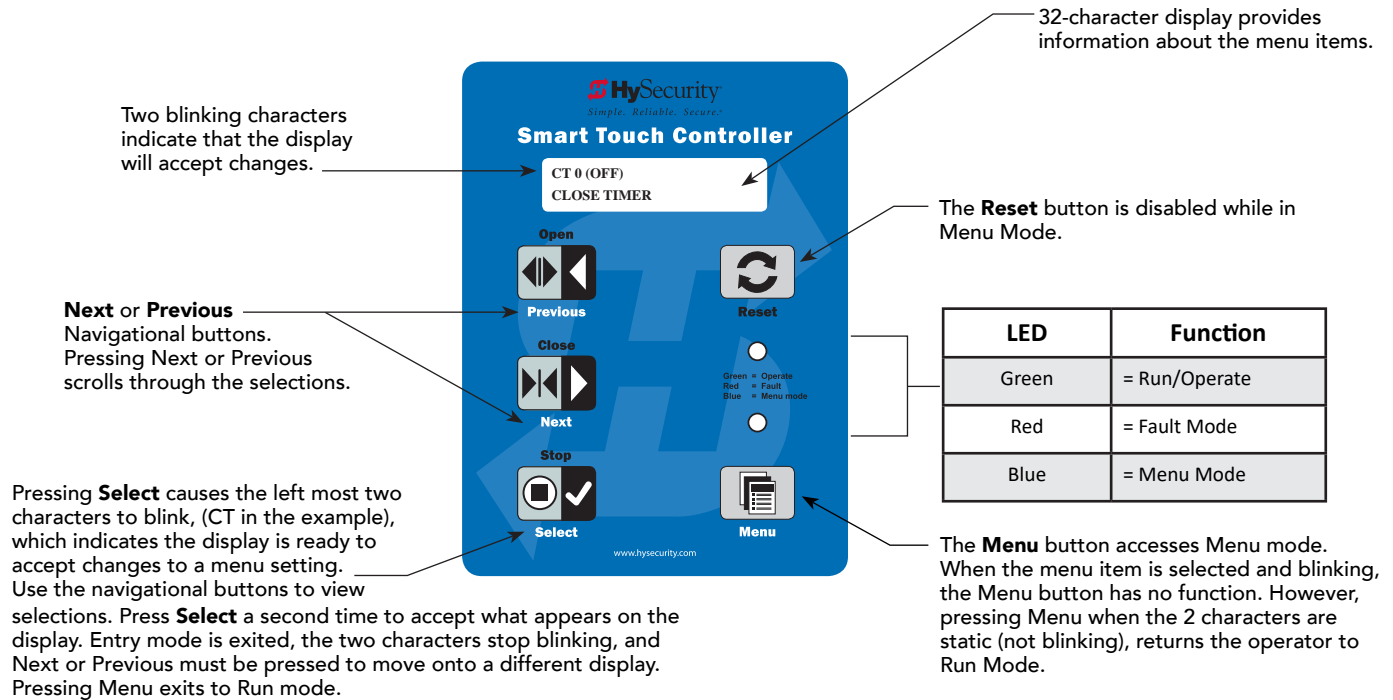

MENU MODE NAVIGATION

Navigating within the program menus is easy once you learn how the keypad buttons function. Refer to the following chart.

Smart Touch Controller: Menu Mode Navigation Buttons

To access Menu mode	To change menu item appearing in the display	To navigate through the menu item selections	To choose what item appears on the display	To navigate between menu items
Press the Menu button twice.	Press Select. Two left characters blink.	Press Next or Previous. Continue pressing Next to view all selections.	Press Select. Blinking characters become static.	Press Next or Previous. Advance - press Next Previous - press Previous

RUN MODE AND THE STC KEYPAD

The Run Mode displays appear static when the operator is ready and waiting for a run command. When the display is flashing GATE OPENING or GATE CLOSING, a command has been received and the barrier gate is in motion. The command may come from a variety of sources: a card reader, push-button remote, or recognition of a vehicle passing over a loop detector. In all cases, the operator “runs” the motor when it receives an operational command.

Three displays indicate the position or status of the gate. The keypad entry used to access the User or Installer menus, begins at one of these Run Mode displays.

32-character display identifies operator status.

Pressing Open, Close, or Stop causes the gate to perform the command.

Pressing Reset clears alerts or faults and returns to Run Mode. **NOTE:** Press Reset at any Run mode status display to view the software version. For example: **h4.55**

Pressing Menu scrolls through operator status displays and accesses the User Menu. **NOTE:** Pressing the Menu button twice, bypasses the operator status displays.

Run Mode Displays

NOTE: To access the User or Installer menus, the motor cannot be engaged and the gate cannot be moving.

VIEWING GATE OPERATOR SCROLLING STATUS

Press the Menu button once and the operator status displays scroll past in two second intervals. Pertinent information appears to provide a quick overview of the operator’s status or configurations.

The type of information that may scroll across the display includes: interlocked or sequenced gate (if applicable), operator type (OT), Usage Class (UC), buss voltage, and life cycle counter.

LED	Function
Green	= Run/Operate
Red	= Fault Mode
Blue	= Menu Mode

The following chart describes a few of the scrolling status displays that may appear in your gate operator.

Operator Status Display	Variables	Description
Build Year	Indicates whether the gate operator was manufactured before or after UL 325 - 2016 Safety of Standard changes that require monitoring of external entrapment sensors.	All gate operators manufactured in 2016 or later will show Build Year - Post 2016 because it contains software version h4.50. If you plan to upload 4.50 software (or later) into your gate operator, you will need to set the appropriate build year according to the date of manufacture. In h4.57 and h5.58 software, or later, BY 2 is for operators built between January 1, 2016 and July 31, 2018. BY 3 is for operators built after July 31, 2018.
Dual Gate or Sequenced Gate	This display only appears when the operator is used in interlocked or sequenced gate systems and indicates the function of the operator. Refer to <i>Bi-Parting & Dual Gate Systems</i> on page 75 and <i>Table 5 describes the User Menu items and supplies the factory defaults.</i> (Factory default settings shown in bold.) <i>Table 5: User Menu</i> on page 51.	Indicates, in an interlocked or dual gate setting, whether the operator is set to Primary or Secondary or Sequenced Gate Configuration). The setting is assigned in the Installer Menu.
Operator Type (OT)	1 = SlideDriver (HSG) all models except 50VF series 2 = SwingRiser (HRG) 3 = HydraLift (HVG) 4 = StrongArm (HTG) 5 = SlideWinder 24 6 = SlideWinder 38 7 = SlideDriver 50VF 8 = StrongArm CRASH 9 = HydraSwing 10 = HydraSupply XL	Indicates and identifies the operator.
Model Number (MN)	0 = Model type unknown 1 = HydraSwing 150 2 = HydraSwing 80F 3 = HydraSwing 40 and 40 Twin 4 = HydraSwing 40F	Identifies the HydraSwing model.
Open Position (OP)	R = Retracted and E = Extended	Indicates position of cylinder when the gate is fully open.
Usage Class (UC)	1, 2, 3, or 4	Displays the operator's Usage Class designation per UL 325 standards.
Input Voltage VDC	The number varies depending on the voltage that the power board is providing.	Input voltage (DC Buss voltage) to the STC is shown. Helps to determine proper power connections.
Cycle Count (CC)	One cycle equals a full open and close sequence. Partial cycles are not counted	Displays the number of cycles the gate operator has incurred. Similar to an odometer, it resets to zero after 999,999 cycles.
Close Timer (CT)	The first menu item in the User Menu. NOTE: You can also access the Installer Menu from this display.	Displays the number of seconds before the open gate initiates.

Stop the Status Display Scrolling

To stop the operator status display scroll and focus on one item, press Select. Press Select a second time, to resume the scrolling display.

Change the Contrast on 7 Segment Displays

NOTE: Since sunlight does not affect readability on the OLED display, changing the display contrast is not available on models shipped with the 32 character display.

While the operator status displays are scrolling, you can change the contrast by pressing the up or down arrow keys. The display's contrast changes accordingly.

Display Power Saving Mode

To conserve energy, the display dims after a period of time if no key press, run command or fault occurs. When an event (key press, run command, or error/alert/fault notification) occurs, the display returns to full brightness.

Check the Software Version

Press Reset. The display indicates the software version loaded on the gate operator. To upload software, you will need a PC laptop. For more information, refer to *Smart Touch Analyze and Retrieve Tool (S.T.A.R.T.)* on page 122.

Check Time and Date

An easy way to determine if your operator is set for the correct date and time zone can be accomplished by taking the following steps:

1. While in Run mode (gate status appears in the display), press and hold the STOP button.
The date appears DD/MM, and then the time HH:MM.
2. If you need to change the time zone, refer to the Set Clock "CL" item in the User Menu. Refer to *Table 5 describes the User Menu items and supplies the factory defaults. (Factory default settings shown in bold.)* Table 5: User Menu on page 51.

USER MENU

The User Menu consists of several items which can be modified using the Smart Touch Controller keypad.

NOTE: To access the User Menu, the operator must be in Run Mode. To bypass the operator status displays, press the Menu button twice.

Access:

Pressing the Menu button, while the gate status is being displayed initiates the gate operator status to scroll. When the scrolling display stop, the first user menu item appears.

The Close Timer (or HC, Hold to Close) display is the first in a cyclical series of User Menu displays.

The LED on the keypad appears blue to indicate Menu Mode.

Use the navigational buttons, Select, Next, and Previous to change or view the menu functions. Refer to the chart, *Smart Touch Controller: Menu Mode Navigation Buttons* on page 47.

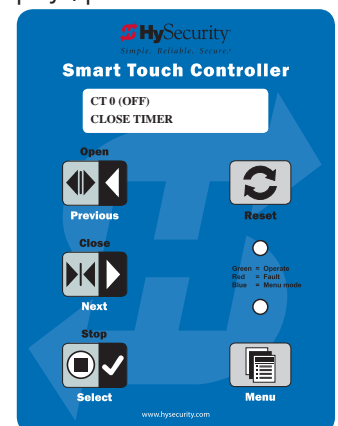

Table 5 describes the User Menu items and supplies the factory defaults. (Factory default settings shown in bold.)

TABLE 5: USER MENU

User Menu	Setting Options	Menu Tasks & Explanations	STC Wire Connections
CT 0 (OFF) CLOSE TIMER	0 = (OFF) Timer disabled 1 second to 99 seconds	Assign how many seconds before open gate initiates automatic closure. Keep setting at 0 if a hardwired, push-button control device is being used. NOTE: CLOSE TIMER display does not appear when HOLD TO CLOSE is set to 1.	Not applicable (N/A)
HC 0 (OFF) HOLD TO CLOSE	0 = off 1 = on	Set to 0 produces a gate closure when a momentary signal is transmitted. Set to 1 if a constant hold to close signal, such as a push button control, is being used. A setting of 1 also deactivates automatic close timer and causes its menu to disappear. You must set HC to 1 to comply with UL 325 Type D protection. Refer to Table Notes. NOTE: To comply with UL 325 Type D protection, set HC to 1. Type D UL 325 compliance means no automatic closing device, such as a timer, loop sensor, or similar device shall not be employed.	COM Close
HO (OFF) HOLD TO OPEN	0 = off 1 = on	Similar to Hold to Close, but configures the Open inputs for a constant-hold function. 0 = Momentary open signal 1 = Constant hold open push button required To comply with UL 325 Type D protection, you must set HO to 1.	COM Open
AP 0 AC LOSS UPS FAIL OPEN	0 = UPS FAIL OPEN 1 = UPS FAIL CLOSE 2 = AUTO OPEN 3 = NO CLOSE TIMER	Setting designates what action gate performs during an AC power loss.	COM Terminal #21 UPS Terminal strip 24 VDC to control box power disconnect switch - and +
RO 0 (OFF) RADIO OPEN/CLOSE	0 = off 1 = on	Configures radio input for open only (0). If changed to setting 1 then adds capability for radio input to close gate, but only when gate is fully open.	COM RADIO Open
BF 2 (ON 2 SEC) WARN BEFORE OPER	0 = off 1 = on 2 = on	Controls the warn-before-operate buzzer and can be configured three ways: Set to 0: Buzzer is disabled. The buzzer will still beep if alerts, faults, errors, or entrapment occur. Set to 1: Buzzer beeps for 3 seconds before gate moves and continues through entire length of travel. Set to 2: Buzzer beeps for 3s before gate moves and continues for 2s of travel.	Not applicable (N/A) Do NOT cut wires to buzzer or unplug it as operator will not be in compliance with UL 325. Failure to comply may result in serious injury or death.

Table Notes:

The following conditions apply to the indicated reference-numbered menu selections:

Table Note 1:

For gate operators using Type D entrapment protection, an automatic closing device (such as a timer, loop sensor, or similar device) shall not be employed.

Table Note 2:

WARNING: Do NOT cut the wires to the buzzer or unplug it as the operator will not be in compliance with UL 325. Failure to comply may result in serious injury or death.

User Menu	Setting Options	Menu Tasks & Explanations	STC Wire Connections
FA 0 (OFF) FORCE OPEN ALERT	0 = off 1 = on	Intended for highly secure facilities. Set to 1, the operator sounds the 3-second "warn before operate" buzzer alarm and initiates a closure if the gate is forced open and the closed limit switch disengages. The motor starts to secure the gate. If the gate does not fully close within 4s, the motor turns off and the buzzer sounds for 30 seconds. The display shows ALERT 1 - FORCED OPEN.	N/A
DA 0 (OFF) DRIFT CLOS ALERT	0 = off (standard) 1 = on (detailed)	Set to 1, the operator sounds the 3-second "warn before operate" buzzer alarm and initiates an open command if the gate is forced, or drifts, off the open limit switch. The motor starts to reopen the gate. The motor runs for a maximum of 4s and, if the gate is not fully open at the end of this period, the buzzer sounds for 10s. The display shows ALERT 2 - DRIFT CLOSED.	N/A
PE 0 (OFF) PHOTO EYE ALIGN	0 = off 1 = on	Set to 1, the operator serves as an aide in photo eye transmitter/receiver alignment. Buzzer chirps once when emitter and receiver are not aligned. When emitter and receiver are aligned, buzzer chirps twice. If they go out of alignment again, buzzer will chirp once. Alignment Mode is reset with a limit input or reset input. Refer to <i>Supply Power to the Sensors</i> on page 41.	Sensor 1, 2 or 3 Sensor COM
CL 0 SET CLOCK	0 = off 1 = on	To set or adjust minute, hour, day, month or year, select 1. Once clock is set, display automatically returns to 0 setting. Significant gate events are logged and stamped with time and date. This feature is useful to read historical operation data, which can be accessed with a computer via USB or RS232 port or the LG setting in User Menu.	N/A
LD 5 LCD CONTRAST	5 0 through 9	Under some extreme high or low temperature conditions, it may be necessary to adjust LCD contrast. Display is adjustable from 0-9 with a factory default setting of 5.	N/A

Table Notes:

The following conditions apply to the indicated reference-numbered menu selections:

Table Note 1:

For gate operators using Type D entrapment protection, an automatic closing device (such as a timer, loop sensor, or similar device) shall not be employed.

Table Note 2:

WARNING: Do NOT cut the wires to the buzzer or unplug it as the operator will not be in compliance with UL 325. Failure to comply may result in serious injury or death.

User Menu	Setting Options	Menu Tasks & Explanations	STC Wire Connections
LG 0 (OFF) VIEW EVENT LOG	0 = off 1 = on	With v4.52 (or later) software, you can set LG to 1 and view abbreviated event logs on the display. These messages are helpful for diagnostic purposes and reviewing the gate operator's event history. Over 300 events can be logged before the software begins overwriting the existing history. Refer to <i>Access the Event Log through the User Menu</i> on page 117.	N/A
DS 0 (OFF) DIAGNOSTIC LOGS	0 = off (standard) 1 = on (detailed)	Set this item to 1 to record all gate operator open and close events, in addition to normal alert, fault and error logs. This parameter automatically resets to the default 0 (off) after 24 hours, which is useful when experiencing intermittent problems. Set to 0, DC Controller logs pertinent gate operator events such as faults, errors, or menu manipulation.	USB or RS232 cable and laptop computer with HySecurity's free START software is required to read log file. Visit www.hysecurity.com
PD 0 SET PASSWORD	0 = Off 1 = On (Set Password)	NOTE: A System Address (SA) value in the installer Menu must be set before the Set Password display appears in the User Menu. To enter a password (up to 80 characters) for network connectivity, select 1. You can use the menu navigation buttons to enter the password. When the password is set, the display returns to the 0 setting.	Network: Ethernet or RS-485 HyNet configuration

Table Notes:

The following conditions apply to the indicated reference-numbered menu selections:

Table Note 1:

For gate operators using Type D entrapment protection, an automatic closing device (such as a timer, loop sensor, or similar device) shall not be employed.

Table Note 2:

WARNING: Do NOT cut the wires to the buzzer or unplug it as the operator will not be in compliance with UL 325. Failure to comply may result in serious injury or death.

INSTALLER MENU

The Installer Menu options provide more advanced configurations for the gate operators. Access to the Installer Menu is through the User Menu. The navigational buttons are the same in both menu modes. Refer to *Menu Mode Navigation* on page 47.

Access:

While a static gate status is being displayed, press the Menu button twice. (Bypasses the operator status displays.)

When the Close Timer display appears (Hold to Close, if the Close Timer display is hidden):

1. **Access the Installer Menu** by simultaneously pressing and holding the Reset and Open buttons.
2. Release both buttons and the display changes, indicating you have arrived at the first item in the Installer Menu.

NOTE: Installer Menu options can also be configured through the use of a laptop computer and S.T.A.R.T. software. See [Smart Touch Analyze and Retrieve Tool](#) information found on the HySecurity website: www.hysecurity.com

Table 6 describes the Installer Menu items and supplies the factory defaults. (Factory settings shown in bold.)

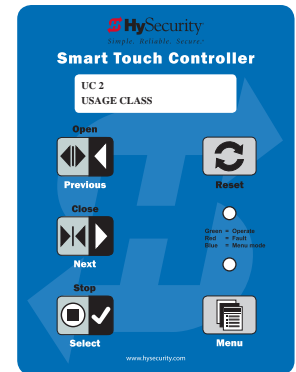
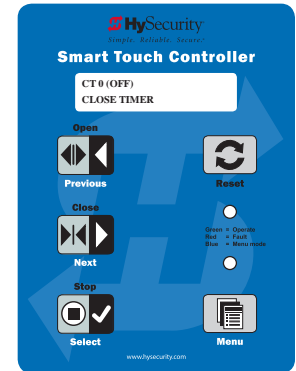
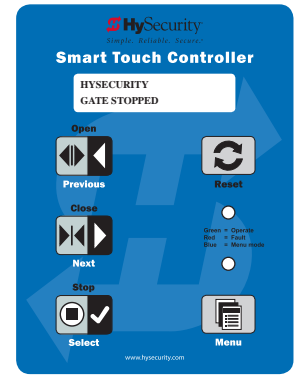

TABLE 6: INSTALLER MENU

Installer Menu	Setting Options	Menu Tasks & Explanations	STC Wire Connections
OT 0 <model name>	0 = Operator Type 1 = SlideDriver (HSG) all models except 50VF series 2 = SwingRiser (HRG) 3 = HydraLift (HVG) 4 = StrongArm (HTG) 5 = SlideWinder 24 6 = SlideWinder 38 7 = SlideDriver 50VF 8 = StrongArm CRASH 9 = HydraSwing 10 = HydraSupply XL	Select the appropriate number for the operator. NOTE: This menu item only appears if the Smart Touch Controller is being replaced. CAUTION: If you are replacing an STC board, remember to transfer the operator's menu settings from the existing board to the replacement board. Refer to the installation instructions that accompany the replacement STC board.	Not applicable (N/A)

Installer Menu	Setting Options	Menu Tasks & Explanations	STC Wire Connections
AD 0 AC/DC GATE	0 = gate disabled 1 = AC (alternating current) 2 = DC battery-power 3 = HyInverterAC – Power Supply	Usually, power type (AC or DC) is factory set. Select the type of power that the gate operator uses and is appropriately wired for.	Not applicable (N/A)
MN 0 Model Number	0 = model type unknown 1 = HydraSwing 150 2 = HydraSwing 80F 3 = HydraSwing 40 and 40 Twin 4 = HydraSwing 40F	Select the type of HydraSwing model used at the site. NOTE: This menu item only appears when you replace the STC board or reset the OT (operator type) using S.T.A.R.T.	N/A
SP 0 SET SPEED (or indicate Modbus control)	0 = gate disabled 1 = No ModBus communication** 2 = 2 ft/s 3 = 3 ft/s **NOTE: A setting of 1 indicates no ModBus communication or wiring is present. The VFD uses its factory settings to control speed.	NOTE: This menu item only appears on the SlideDriver operator if it is part of the 50VF series. It does not appear with any other operator type. Set the maximum speed for the gate. CAUTION: Slow Down extended limit ramps must be installed on the drive rails!	N/A
UC 0 USAGE CLASS	0 = gate disabled 1 = single family dwelling 2 = multi-family 3 = industrial * 4 = guarded location * *not serving the general public	Designates the UL 325 Usage Class (UC). The installer sets the usage class for the operator to function. NOTE: The usage class setting does not appear on Crash products.	N/A
SH 0 GATE HANDING	0 = gate disabled R = viewed from the secure side, the gate moves right to open L = viewed from the secure side, the gate moves left to open	NOTE: Handing only appears on slide gate operators. On slide gates, the installer sets the operator's handing before the operator will function, so an R or L appears in the display.	N/A
OP 0 Open Position	0 = gate disabled R = retracted. E = extended	HydraSwing only: The installer must identify the cylinder's open position before the operator will function. Set OP to R if the cylinder is retracted when the gate is open. Set OP to E if the cylinder is fully extended when the gate is open. Refer to the HydraSwing Installation Instructions for graphical representations	N/A
BU 0 LOUDEST BUZZER	0 = buzzer not set 1 = Frequency 1 * (on) 2 = Frequency 2 * (on) *Select the loudest buzzer	Usually, set at the factory. If menu item appears, select either buzzer 1 or 2. Make sure to choose the loudest audible buzzer sound for your operator type.	N/A
FD 0 (OFF) FACTORY DEFAULTS	0 = user settings (custom) 1 = reload factory settings	Globally restores all menu settings back to new operator status. Select setting 1 to return operator to factory defaults. NOTE: If factory defaults are restored, the UL usage class, handing, gate weight, and any other modified menu settings will need to be reprogrammed.	N/A

Installer Menu	Setting Options	Menu Tasks & Explanations	STC Wire Connections
DG 0 (OFF) DUAL GATE	0 = solo operator 1 = Secondary unit 2 = Primary unit 3 = Sally Port A 4 = Sally Port B	Configures gate operator as a Primary or as a Secondary in a dual-gate installation. When you assign one unit as Primary, you must configure other as Secondary through Installer Menu. This menu is also used to configure a Sally Port system by setting one operator to Sally Port A and the other to Sally Port B.	3-wire shielded cable to DUAL GATE input terminals. Connect Dual Gate COM (Gate 1) to Dual Gate COM (Gate 2). Pair wires: A - A, COM - COM, and B - B. NOTE: HySecurity recommends using a 2-pair, twisted, shielded cable with one pair of wires used to connect A-A and B-B terminals between the two boards. The other pair will connect the Common terminals. The shield should then be grounded on one end to one of the operators.
SG 0 (OFF) SEQUENCED GATE	0 = off 1 = Loop Layout/Site #1 2 = Loop Layout/Site #2 3 = Loop Layout/Site #3 4 = Loop Layout/Site #4	Establishes communication after wiring two gate operators as sequential gates. This SG menu item only appears if the Dual Gate menu item (DG) is set to 0 (solo operator). NOTE: After selecting SG settings, consider accessing the User Menu in each gate operator to address the Close Timer (CT) setting. HySecurity recommends using a 2-pair, twisted, shielded cable with one pair of wires used to connect A-A and B-B terminals between the two boards. The other pair will connect the Common terminals. The shield should then be grounded on one end to one of the operators.	3-wire shielded cable to DUAL GATE input terminals on both operators. Pair wires: A - A, COM - COM, and B - B. NOTE: HySecurity recommends using a 2-pair, twisted, shielded cable with one pair of wires used to connect A-A and B-B terminals between the two boards. The other pair will connect the Common terminals. The shield should then be grounded on one end to one of the operators.
CH 0 (AC) CHARGER TYPE	0 = AC powered charger 1 = Solar powered charger	NOTE: Does not appear on an AC-powered operator. The menu item only appears when using the DC Charger unit and designates the charger type. Assigns charger type usually set at factory. If set to solar at factory then this menu item is hidden.	N/A
FO 0 (DISABLED) FIRE DEPT OPEN	0 = disabled 1 = enabled	Enables Fire Department Open input. When set to 1, signal received through this input overrides all photoelectric eyes and edge sensors and opens gate. Pressing RESET button (or the OPEN push button) is required before gate can be closed.	+24V Fire Dept Open (#24)

Installer Menu	Setting Options	Menu Tasks & Explanations	STC Wire Connections
OC 0 (DISABLED) EMERGENCY CLOSE	0 = disabled 1 = enabled	Enables the Emergency Close input. When set to 1, the constant hold close overrides vehicle detectors, photo eyes and edge sensors, and closes the gate. Pressing the Reset button once or the Open button twice is required before the gate will open.	+24V EMERG CLOSE (#23)
SE 2 IES SENSITIVITY	1 = maximum sensitivity 2 = moderate (default) 9 = lowest sensitivity	Adjusts the sensitivity of the inherent entrapment sensor. Available settings are 1-9 with 9 being the least sensitive.	N/A
SS 0 IES STOP ONLY	0 = (off) Stop and reverse for 2s 1 = (on) stop only	In a Usage Class 4 environment, operator can be set to stop gate and not reverse gate travel after an IES trip.	N/A
LC 0 LEAF DELAY CLOSE	0 = none 1 to 20	Only appears if the gate operator is set up as a Primary or a Secondary. Available settings are 1 to 20. Each numerical increment adds ½ second, to a maximum of 10 seconds time delay, before the operator activates when commanded to close.	
LO 0 LEAF DELAY OPEN	0 = none 1 to 20	Only appears if the gate operator is set up as a Primary or a Secondary. Available settings are 1 to 20. Each numerical increment adds ½ second (with a maximum of 20 seconds) time delay following a command to open before the operator activates.	
RT 0 (60 SECS) MAXIMUM RUN TIME	0 = 60 Seconds max run 1 = 300 Seconds max run	Allows an optional setting of 300 seconds if changed to [RT 1] as opposed to the maximum run timer default setting of 60 seconds.	N/A
PO 0 (OFF) PARTIAL OPEN	0 = none 7 to 99 seconds	Sets distance (from closed gate position) where gate stops if the partial open input is activated. When a number is entered in PO display, open partial input becomes operational. Only available in Slide Gate operators.	Open Partial #6 COM
EC 0 STOP ONLY EYE CLOSE LOGIC	0 = Close eye stops only 1 = Two second reversal to open on swing, slide, or vertical gates. 2 = Reverse to full open.	Default setting is non-reversal if close photo eye is triggered while closing. A setting of 1 causes gate to reverse toward open for two seconds if triggered while closing. A setting of 2 reverses the gate to full open.	.Sensor 1, 2, or 3 Sensor COM COM +24V
EO 0 STOP ONLY EYE OPEN LOGIC	0 = Open eye stops only 1 = Two second reverse to close	Default setting is non-reversal if open photo eye is triggered while opening. A setting of 1 causes gate to reverse travel and close for two seconds if triggered while opening.	Sensor 1, 2, or 3 Sensor COM COM +24V
GR 0 FULL OPEN GATE EDGE LOGIC	0 = Edge reverses fully open 1 = Two second reversal only	Default setting is a full-open reversal if gate edge is triggered while closing. Optional setting of 1 causes gate to reverse for two seconds if triggered while closing.	Sensor 1, 2, or 3 Sensor COM +24V 10K resistor (Edge)
SR 1 REVERSE 25 REVERSAL LOGIC	0 = IES reverses fully open 1 = Two second reversal only	Default setting is a two-second duration reversal if inherent sensor is triggered. Optional setting of 0 will cause gate to reopen fully if triggered while closing.	N/A

NOTE: The shaded Installer Menu items do not appear when Build Year is set to 2 (BY 2). Exceptions exist for barrier arms, CRASH products, operators set to pre-2016 and Usage Class IV provisions.

Installer Menu	Setting Options	Menu Tasks & Explanations	STC Wire Connections
S1 0 SENSOR #1 TYPE	0 disabled 1 (NOT USED) 2 (EYE CLOSE) 3 (EDGE CLOSE) 4 (EYE OPEN) 5 (EDGE OPEN) 6 (EDGE BOTH) 7 (EYE BOTH)	UL 325 - 2016 sensor input setting for external entrapment protection sensor monitoring. All three sensor types must be configured to a non-zero number before the gate operator will move the gate. Edge Both is only available in Swing Gate operator types. Eye Both is only available in Slide Gate operator types. <i>Refer to External Entrapment Protection Sensors: What the Installer Needs to Do on page 38.</i>	SENSOR 1 COM +24V SENSOR COM 10K resistor ** (Wired Edge sensor)
S2 0 SENSOR #2 TYPE	Same as Sensor 1	Same as Sensor 1	SENSOR 2 COM +24V SENSOR COM
S3 0 SENSOR #3 TYPE	Same as Sensor 1	Same as Sensor 1	SENSOR 3 COM +24V SENSOR COM
PC 1 NO INPUT PHOTO EYE OUTPUT	0 = Normally Open NO input 1 = Normally Closed NC input (supervised)	This menu item only appears when UC is set to 4. Default setting is photo eyes with Normally Close outputs. Optional setting 0 requires a Normally Open (NO) output. When set for NC, connection is monitored and any short circuit fault will generate a FAULT 2 alert which requires a STOP or RESET button press to re-enable gate operation.	COM +24V COM PHOTO EYE CLOSE DIRECTION
GC 0 NO INPUT GATE EDGE OUTPUT	0 = Normally Open NO input 1 = Normally Closed NC input (supervised)	This menu item only appears when UC is set to 4. Default setting is edge sensor with Normally Closed (NC) output. Optional setting of 0 requires an (NO) output..	COM +24V COM EDGE SENSOR
TC 1 (INTLOCK) TIME CLK/INTLOCK	0 = TIME CLK (Select Time Clock) 1 = INTLOCK (Select Open Interlock)	Configures the input at Terminal No. 7 on the STC to be either for the gate interlock function, or for an external time clock to open input. The default setting is (TC_1) for the interlock function.	INTERLOCK OPEN (#7) COM
DT 0 FREE EXIT DISABLE FUNCTION	0 = Disable Free Exit 1 = Disable Close Timer	Configures BLOCK EXIT input to disable either Free Exit Detector function or, alternately, Close Timer function. Default setting disables free exit detector. NOTE: Free exit is disabled when gate is at its closed limit. If closed limit is not tripped, free exit continues to work normally.	BLOCK EXIT COM
OR 1 REVERSE OUTSIDE OBS LOOP	0 = Pause closing only 1 = Enable reversing to open	Default is for full reversal when Outside Obstruction Loop is triggered while closing. A setting of 0 causes gate to only pause when triggered. Gate closure continues as soon as loop is clear again..	OUTSIDE OBS LOOP COM or Hy5B
IR 1 REVERSE INSIDE OBS LOOP	0 = Pause closing only 1 = Enable reversing to open	Default is for full reversal when Inside Obstruction Loop is triggered while closing. A setting of 0 causes gate to only pause when triggered. Closure begins as soon as loop is clear again.	INSIDE OBS LOOP COM or Hy5B

Installer Menu	Setting Options	Menu Tasks & Explanations	STC Wire Connections
HD 1 HOLD CLOSE Center Loop Hold	0 = Hold Open only 1 = Hold Close and hold Open	Swing gates: Configures the function of the Center Loop (Shadow Loop) when triggered: Setting 1 - holds the gate from starting open and from starting close. This setting prevents opening and closing of the gate when the Center Loop is tripped if the gate is on either (opened or closed) limit switches. Setting 0 - holds the gate from starting closed. This setting prevents closing when on the open limit switch.	CENTER LOOP (#10) COM or connection to Hy5B detector
DL 1 STANDARD DETECTOR LOGIC	1 = Standard 2 = Quick Close 3 = Forced Time out 4 = Full anti-tailgate	This selection determines whether close timer begins to count down after vehicles have departed detector loops or whether close timer will count down while the loops are occupied. Gate can only close when all loop detectors are clear. Default settings causes Close Timer to start when all loops are clear. A setting of 2 causes Close Timer to start when open limit is reached. A setting of 3 forces the Close Timer to 0 when the OOLD and IOLD are tripped simultaneously. A setting of 4 stops the gate when OOLD and IOLD are tripped simultaneously and closes from that point when the loops clear.	
RL 1 DISABLED RELAY 1 LOGIC	0 = Default (default is 1 on hydraulic operartors) 1 to 33 available	Configures function of the user 1 output relay, which is an electromechanical relay. It has capacity to switch, both AC and DC and can be used for high voltage and/or high current loads. Connect devices directly to the top of relay: COM plus NO and NC contacts. Up to 33 optional relay functions exist. Refer to <i>User Relays – Programming Procedure</i> on page 71.	User 1 Relay
R2 6 GATE LOCK RELAY 2 LOGIC	0 = Default (default is 6 on hydraulic operartors) 1 to 33 available	Configures function of user output relay, which is an electronic relay with capacity for switching a DC load only. The User 2 Relay is limited to 48 Volts DC and 4A maximum load. Up to 33 optional relay functions exist. Refer to <i>User Relays – Programming Procedure</i> on page 71.	User 2 Relay
R3 1 CLOSE LIMIT RELAY 3 LOGIC	0 = Default (default is 1 on hydraulic operartors) Up to 33 available	Relay 3 configures the function of the User 3 output relay, which is an electronic relay with the capacity for switching a DC load only. In the StrongArm M30/M50, Relay 3 is connected to the gate LED lighting and does not appear as an option in the Installer Menu.	User 3 Relay
R4 through R11 RELAY <n> LOGIC	0 = Disabled 1 to 33 available	Similar to Relay 1 Logic. NOTE: The Hy8Relay™ module option can be purchased to provide an additional 8 relay terminals. Relay #29 set aside for Factory Use.	COM NOTE: R4 through RB user relays appear on 7-segment display
TL 2 (45 SECS) OPEN TIME ALERT	0 = 0s delay 1 = 15s 2 = 45 second 3 = 75s 4 = 105s 5 = 135s	Adjusts time delay before activating a user relay. Maximum time setting is 135 seconds. NOTE: This menu controls a user relay set to Function No. 8	User Relay 8

Installer Menu	Setting Options	Menu Tasks & Explanations	STC Wire Connections
LT 3 (75 SECS) LOITERING ALERT	0 = 0s delay 1 = 15s 2 = 45s 3 = 75 second delay 4 = 105s 5 = 135s	This function monitors activation of Outside Obstruction Loop when the gate is closed and not running. When adjustable period of time is exceeded, User Relay No. 13 triggers and reports loitering in diagnostics log. Adjust time delay before activating user relay. Maximum time setting is 135 seconds. NOTE: This menu controls a user relay set to Function No. 13	User Relay 13
OS 1 (30 SEC) OPEN SPEED	0 = Run mode 1 = (30 SEC) 2 = (25 SEC) 3 = (20 SEC)	Designate how quickly the gate opens. The range is dependent on the model number the speed varies. Refer to <i>Adjusting the Gate Speed</i> on page 62.	(N/A)
CS 1 (30 SEC) CLOSE SPEED	0 = Run mode 1 = (30 SEC) 2 = (25 SEC) 3 = (20 SEC)	Designate how quickly the gate closes. The range is dependent on the model number the speed varies. Refer to <i>Adjusting the Gate Speed</i> on page 62.	(N/A)
LL 0 (OFF) Learn Limit	0 = Normal setting 1 = Reset Limits	A setting of 1 places operator into its learn limits mode which allows you to reset gate's open and close positions. Refer to "Resetting the OPEN and CLOSE Limits" on page XX. Refer to <i>Initial Setup</i> on page 29 XX.	N/A
SA 0 (OFF) STC ADDRESS	0 = No network 1 to 99 = Network "drop" address	Set system address for network communication: 0 = no network communication 1 - 99 sets individual polling addresses. Use addresses 1-4 when connecting to HyNet.	RS-485. Involves additional hardware & software.
NE 0 (OFF) NETWORK SETUP	0 = No network (off) 1 = Network address (on)	Menu item appears when SA is not set to zero (0). If a system address exists a setting of 1 opens the network configuration menu. 0 = no network communication 1 = allows configuration of network addresses. Used with HyNet™.	RS-485. Involves HyNet™ & software.
ID 0 HYINVERTER DIAGNOSTICS	0 = no diagnostics displayed 1 = view diagnostics displays HYINVERTER INPUT - LINE xxx.x VAC HYINVERTER TEMP - xxx.xF / xxx.x C HYINVERTER VOLTS - BATTERY xx.x VDC HYINVERTER - BATTERY xxx.x %	Controls which system diagnostics appear on the display. With a setting of 1, you can access the AC Power Supply with HyInverter AC diagnostic mode. Use the Next or Previous buttons, on the gate operator's keypad, to view the diagnostics on the STC display. NOTE: These same diagnostics appear on the AC Power Supply with HyInverter AC display in a constant scrolling format.	AC Power Supply with HyInverter AC to STC (Modbus RTU communication protocol via RS-485.)
ELD0 RUN MODE EXIT LOOP SET	0 = Run mode 1 = Show frequency 2 = Show call level 0-7 3 = Set Frequency	Controls Hy5B or HY-5B Free Exit detector. If an HY-5B is used, additional settings of 4-8 are available.	Hy5B
ILD0 RUN MODE IND OBS LOOP SET	0 = Run mode 1 = Show frequency 2 = Show call level 0-7 3 = Set Frequency	Controls Hy5B or HY-5B Free Exit detector. If an HY-5B is used, additional settings of 4-8 are available.	Hy5B
OLD0 RUN MODE OUT OBS LOOP SET	0 = Run mode 1 = Show frequency 2 = Show call level 0-7 3 = Set Frequency	Controls Hy5B or HY-5B Free Exit detector. If an HY-5B is used, additional settings of 4-8 are available.	Hy5B

Installer Menu	Setting Options	Menu Tasks & Explanations	STC Wire Connections
SLD0 RUN MODE SHADOW LOOP SET (Reset Loop Set)	0 = Run mode 1 = Show frequency 2 = Show call level 0-7 3 = Set Frequency	Controls Hy5B or HY-5B Free Exit detector. If an HY-5B is used, additional settings of 4-8 are available.	Hy5B

ADJUSTING THE GATE SPEED

The gate speed designates how quickly the gate opens or closes. The available range varies dependent on the model number. Refer to the chart below.

Two Installer Menu settings, one for OPEN SPEED and one for CLOSE SPEED, can be accessed from the Smart Touch Controller's display. The steps involved in changing the open speed (OS) are shown below. The steps to set the close speed are the same, except you must access the close speed menu item (CS).

HydraSwing	Model	Approximate Speed Settings
150	1	1 = 30s, 2 = 25s, 3 = 20s
80F	2	1 = 25s, 2 = 20s, 3 = 15s
40	3	1 = 20s, 2 = 17.5s, 3 = 15s
40F	4	1 = 15s, 2 = 12.5s, 3 = 10s

RESETTING OPEN AND CLOSE LIMITS

Resetting the open and close limits is easily accomplished by accessing the Installer Menu.

Access to the Installer Menu is through the User Menu. See the flowchart below.

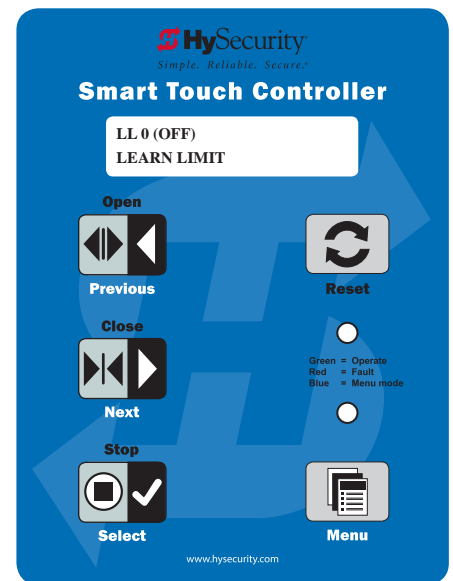
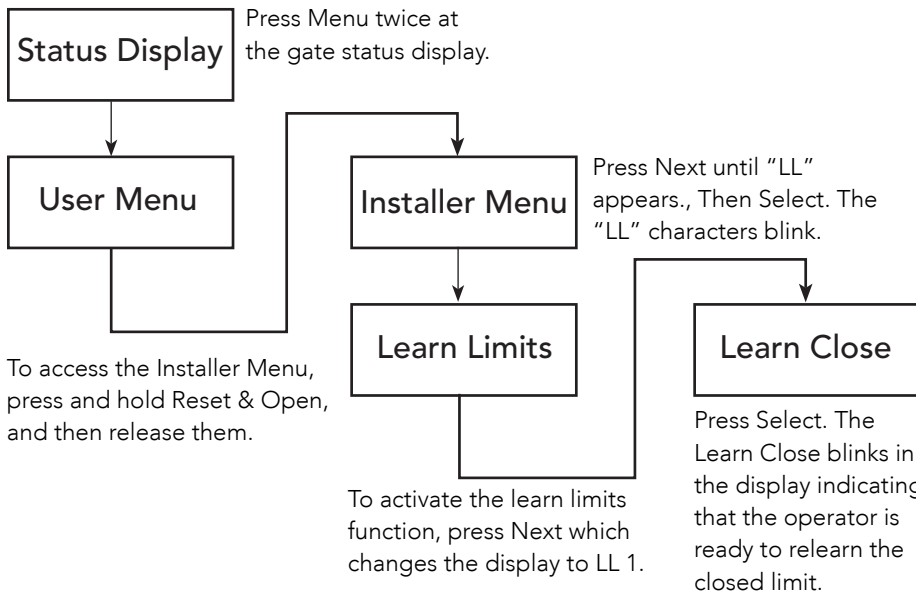

Learn Close Limits

Learn Close appears and blinks, indicating that the operator is ready to learn its close limit. Follow one of the two procedures shown in the bullets:

- The gate is already in the desired closed position – press Stop twice. The buzzer chirps twice and the full close stop is retained in memory.
- The gate is not in the desired closed position - press and hold the Close button until the HydraSwing moves the gate to full close. Release the Close button and press Stop twice. The buzzer chirps twice and the full close stop is retained in memory.

NOTE: During this process, you can press and hold Open to reverse direction and adjust the gate position.

Learn Open Limits

1. When the Learn Open display appears, hold the Open button until the gate reaches the desired full open position.
2. Release the Open button. Note that if you go too far, you can press Close to reverse direction.
3. Press Stop twice to preserve the open stop location. The buzzer chirps twice and the full open stop is retained in memory.

SETTING THE CLOSE TIMER

The Close Timer assigns how many seconds will pass before the gate operator initiates closure of a fully opened gate after all open commands and reversing sensor inputs have ceased and loops cleared. It is recommended that every gate operator have the close timer set to a specific number of seconds (for example, 5 seconds) unless a hard-wired closing device is connected to the gate operator, such as a “hold to close” push button station.

To adjust the time (1 to 99 seconds) it takes before the operator initiates gate closure, take the following steps:

1. At a gate status display, press the Menu button twice. This accesses the User Menu and the Close Timer display appears.

NOTE: If you want gate personnel to operate the gate with the Hold to Close feature found in some push button stations, then set the Hold to Close menu item to 1. When the Hold to Close menu item is active (set to 1), the Close Timer menu item is unavailable.

2. Use the Select, and then Next or Previous buttons to navigate and change the number of seconds appearing on the display. Refer to *Menu Mode Navigation* on page 47.
3. To exit the User Menu, press the Menu button. The gate status appears in the display indicating you have returned to Run Mode.

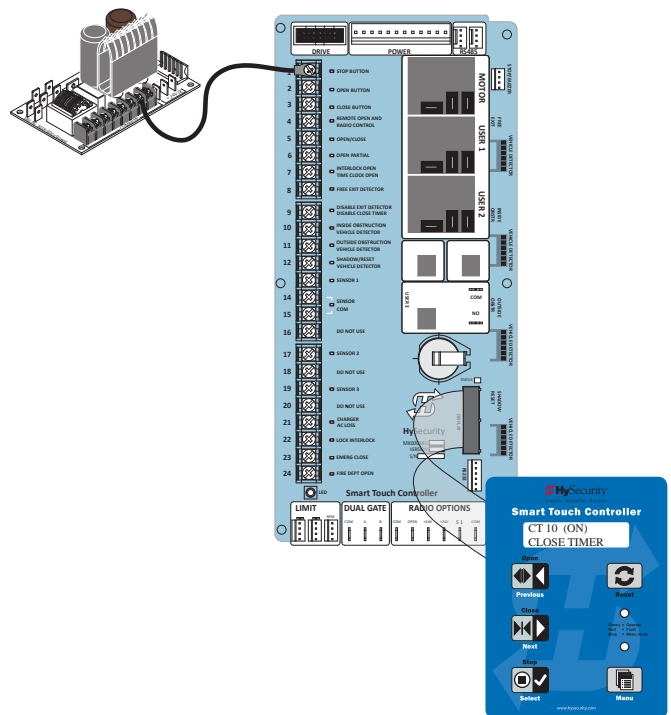

TEST THE OPERATOR

Complete the installation by testing the operation of the gate.

NOTE: The operator must be turned on and in Run mode. A Run mode display appears on the STC. If a Run mode status does not appear on the display, press Reset. If an error, alert, or fault appears on the display, refer to "Troubleshooting" on page 106 to learn how to clear the display and return to Run mode.

1. Press Open to open the gate.
2. Test the operator.
 - Cycle the gate a few times by pressing the Close and Open buttons.
 - If installed for emergency fast operation, test the EMERGENCY CLOSE using the constant hold device. Observe the travel speed of the gate when you press and hold the Emergency Close button. It will close a second or two faster than normal operation and ignore any photo eye, vehicle loop, or other safety sensor inputs.

NOTE: If additional accessories are to be added, read about *STC Inputs & Wiring* on page 65.

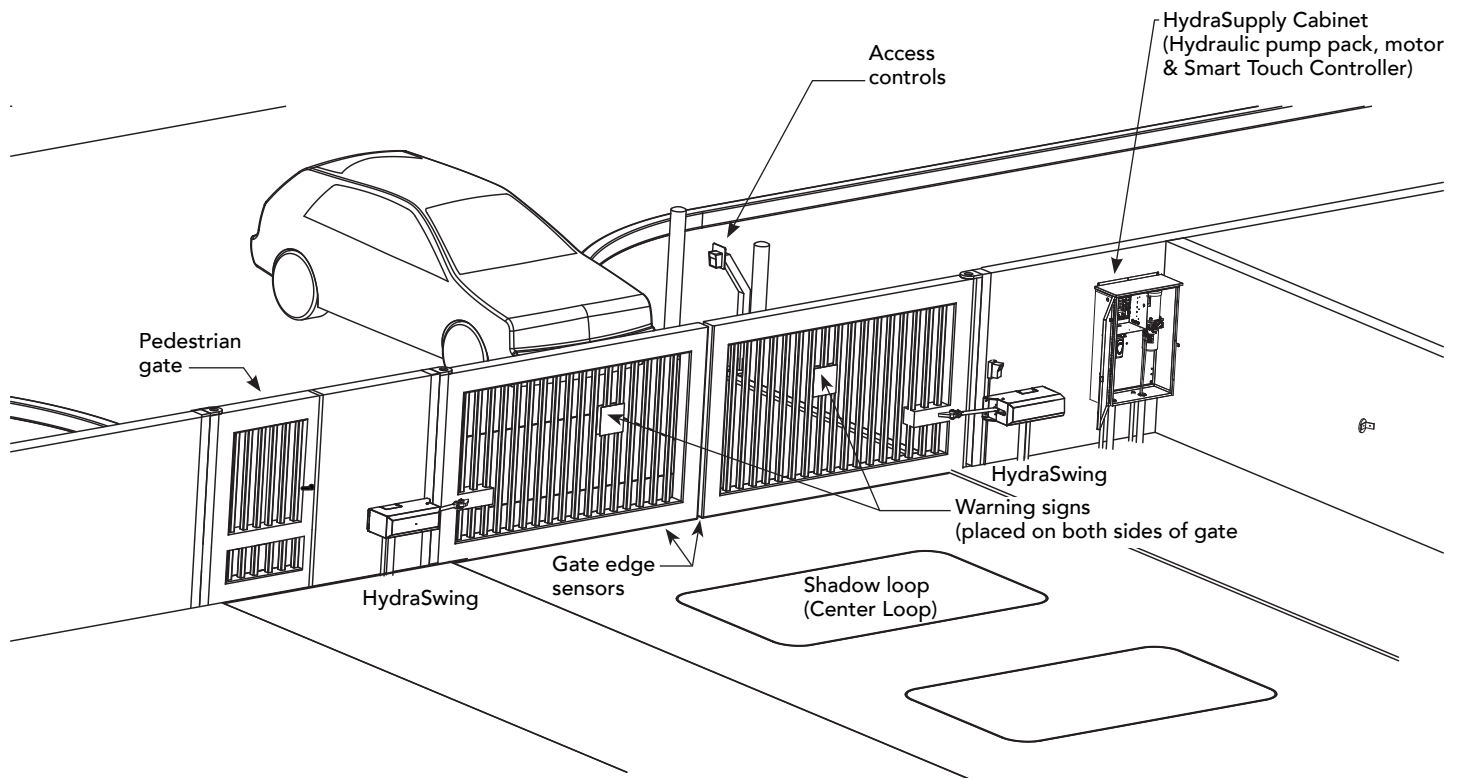

STC Inputs & Wiring

This section provides information about the Smart Touch Controller, its inputs for peripheral connections, and its monitoring capabilities. This section explains how to:

- Make Connections on the Smart Touch Controller
- Integrate with Security Systems
- Adapt User Relays for your Gate Site

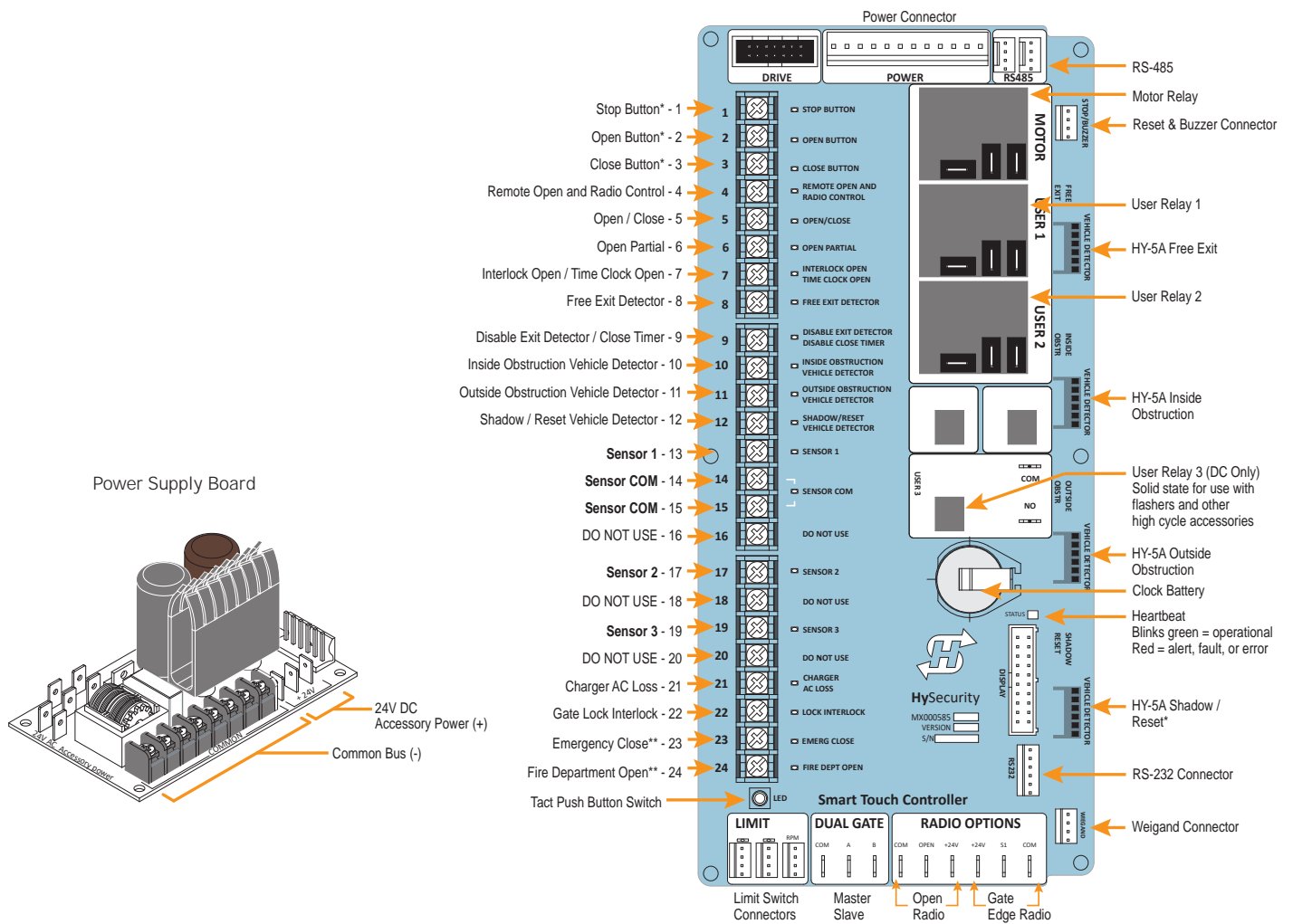
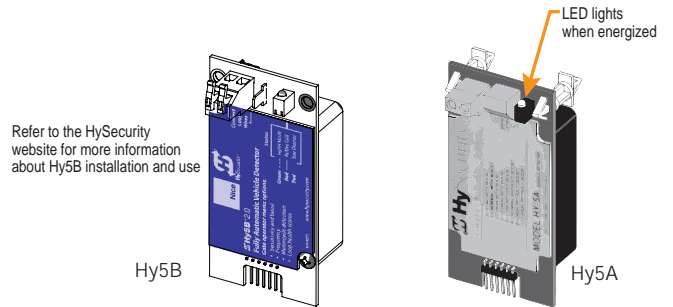

OVERVIEW OF THE STC AND POWER SUPPLY BOARD

The Smart Touch Controller uses LED's to indicate active inputs when AC power is present. For operators that use only DC power, you can push a Tact push button to show the active inputs. This Tact push button is at the bottom left corner beneath the #24 terminal input.

On a new operator, no active inputs should appear until external accessories and wiring are attached. If any inputs are active before connecting external wiring, refer to *Troubleshooting* on page 106.

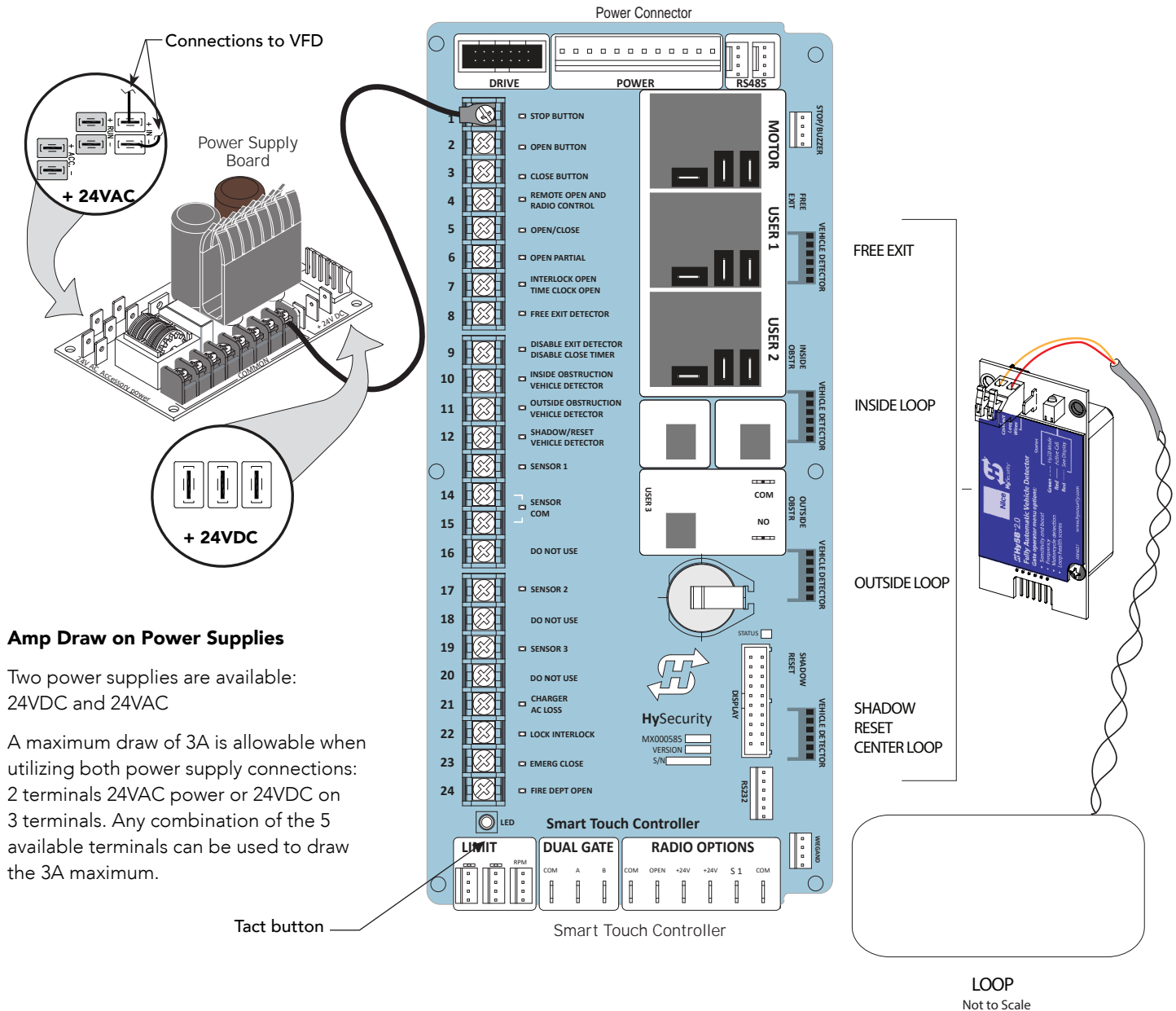

Amp Draw on Power Supplies

Two power supplies are available:
24VDC and 24VAC

A maximum draw of 3A is allowable when utilizing both power supply connections: 2 terminals 24VAC power or 24VDC on 3 terminals. Any combination of the 5 available terminals can be used to draw the 3A maximum.

INTEGRATING WITH SECURITY SYSTEMS AND HyNET™ GATEWAY

HySecurity hydraulic gate operators provides a 2-wire, serial interface (RS-485 connection) which allows remote access to one or more operators. With software protocols provided by HySecurity, bi-directional status updates and control commands are easily integrated with a central controller (computer or server), which becomes the primary (master) to the connected operators. Up to 31 physical operators can be polled from the central master command station. Reset requests, gate control, gate status, and gate faults can be monitored and information can be retrieved from the central command station.

The RS-485 interface is also used to communicate with the HyNet Gateway, a web-enabled interface. To view the user guide and quick start information regarding HyNet Gateway SFP 4/1, go to the HySecurity website, [Technical Support Installation Manuals](#).

NOTE: Connect HyNet power to +24VDC on the Power Supply Board. Do NOT connect HyNet to +24V terminal under RADIO OPTIONS.

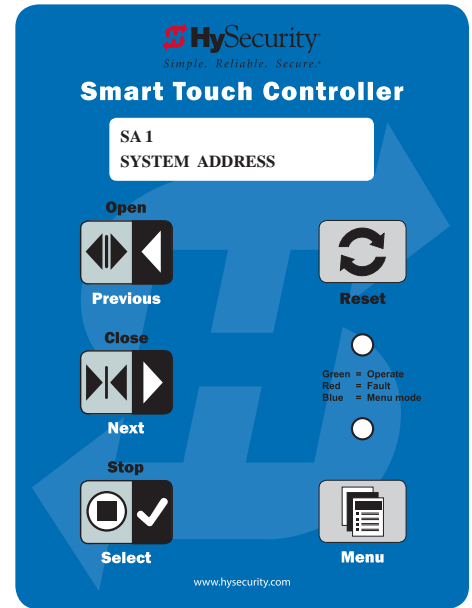
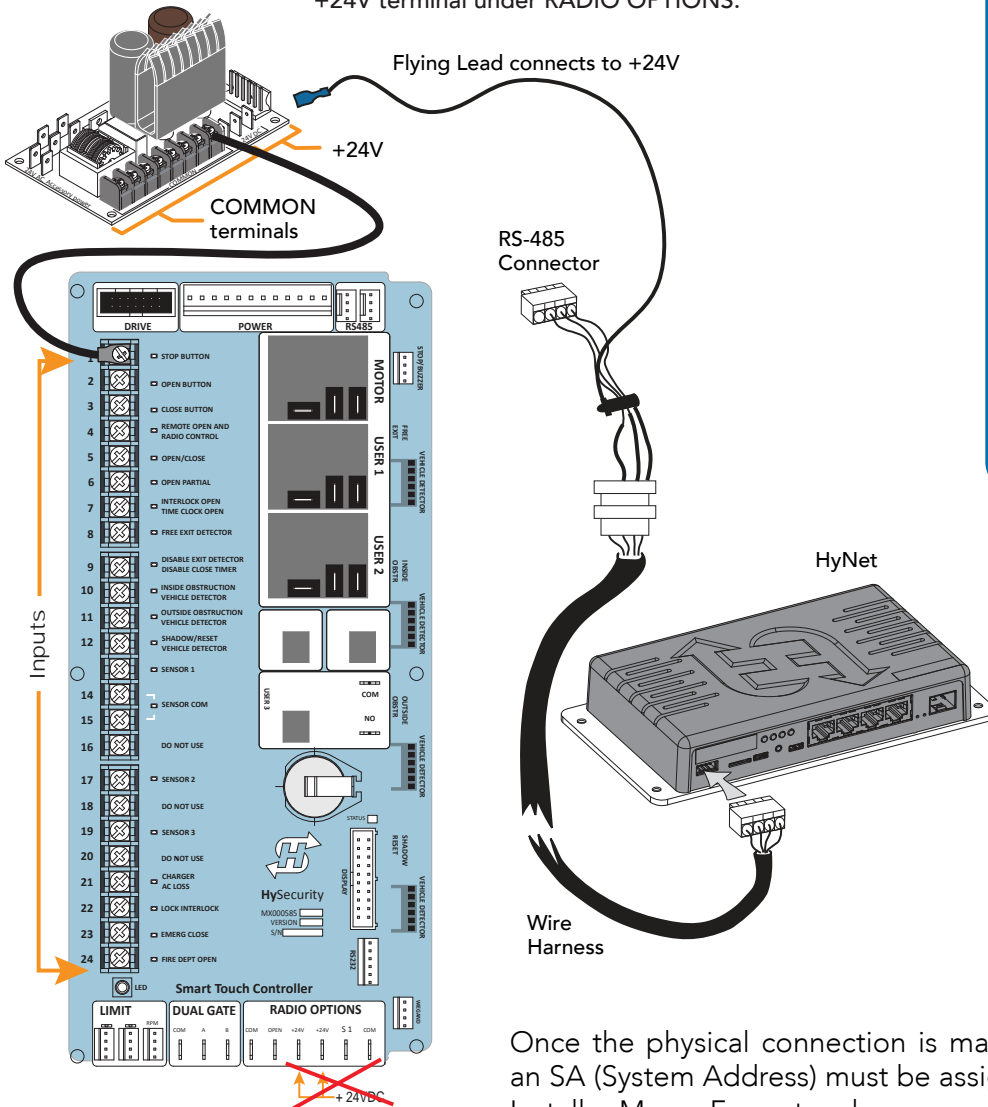

SA Display in the Installer Menu

Once the physical connection is made and protocols are established, an SA (System Address) must be assigned for each operator through its Installer Menu. For network communication, choosing a "SA" of 1 to 99 establishes individual network polling addresses. A "SA" of zero means no network communication is desired.

If you plan to connect operators to a networked central master command station, contact HySecurity for software protocols and additional information. Refer to *Contact Information* on page 2.

SMART TOUCH CONTROLLER INPUTS

When using AC power, an LED lights next to any active input.

1. Test the open and close function of the gate before wiring to accessory devices (external control inputs). This makes it easier to troubleshoot if an unexpected functionality arises.

NOTE: If you are using the operator strictly in a DC capacity, the Smart Touch Controller has a tact button you can push which lights an LED next to the active inputs. This button is in the bottom left corner of the STC board. Press the SHOW LEDs push button switch to verify the status of the terminal inputs.

2. All the Smart Touch Controller inputs listed below are shown as a single input. The second wire is connected to the Common Terminal Bus on the Power Supply Board.

NOTE: The Emergency Close and Fire Dept. Open inputs are an exception and require a +24V input. The +24V is located on Power Supply Board next to the Common Bus. See drawing on previous page.

STC TERMINAL INPUTS



Use Terminal Inputs 4, 5, 6, and 7 for external control devices. DO NOT connect an external control device to Input Terminals, 1, 2, or 3 unless the controls are located in clear view of the entire gate area and are being constantly monitored and supervised.

NOTE: UL 325 2016 sensor input label changes shown in **Bold**.

Smart Touch Controller Inputs Chart

No.	Smart Touch Terminal UL 325 - 2016	Smart Touch Terminal pre-2016	Wire Connections	Commonly used for...
1	Stop Button	Stop Button	Normally Closed input. Jumper to Common if input is not being used.	Line of sight, external stop button or 3-button station.
2	Open Button	Open Button	Do not use for radio or remote access controls. Normally Open Input	Line of sight, external open button or 3-button station.
3	Close Button	Close Button	Do not use for radio or remote access controls. Normally Open Input	Line of sight, external close button or 3-button station.
4	Remote Open & Radio Control	Remote Open & Radio Control	For radio/remote open device: Access the RO from the User Menu and set to 1. NO Input	Remote access control or radio controls
5	Open/Close Button	Open/Close Button	Connection for push button or radio controls.	Singular button device (multi-function)
6	Open Partial	Open Partial	NOTE: Terminal is only used in slide gates. Adjustable through the Installer Menu from 7 to 99.	Monitored access controls

No.	Smart Touch Terminal UL 325 - 2016	Smart Touch Terminal pre-2016	Wire Connections	Commonly used for...
7	Interlock Open/Time Clock Open LED	Interlock Open/Time Clock Open LED	The default is Interlock Open (TC 1) but can be configured as the Time Clock Open (TC 0) input. Refer to your gate operator's product manual.	Sequenced or interlocked gate inputs. Another use for this input is connection to a device that regulates the open timing.
13	SENSOR 1	Edge Sensor	Refer to <i>Table 6: Installer Menu</i> on page 54.	Connection to external entrapment protection sensors.
14	Sensor COM	Photo Eye Power - 24 Volts Common	All devices used for entrapment protection that require monitoring must be connected (wired) to SENSOR COM.	Device common power
15	Sensor COM	Photo Eye Power - 24 Volts Common	Refer to <i>How Software Handles Monitoring External Entrapment Protection Sensors</i> on page 38 and <i>Wiring HySecurity Sensors: Smart Touch</i> on page 129.	Connect external entrapment protection sensors to these terminals. The sensors energize only when the gate operator receives a run command. Use these terminals to preserve battery power. NOTE: For pre-2016 gate operators, inputs are labeled as Photo Eye Power and 24 Volts Common.
16	DO NOT USE	DO NOT USE		
17	SENSOR 2	Photo Eye Open direction	Refer to <i>How Software Handles Monitoring External Entrapment Protection Sensors</i> on page 38.	Connection to external entrapment protection sensors.
18	DO NOT USE	DO NOT USE		
19	SENSOR 3	Photo Eye Close direction	Refer to <i>How Software Handles Monitoring External Entrapment Protection Sensors</i> on page 38.	Connection to external entrapment protection sensors.
20	DO NOT USE	DO NOT USE		
21	Charger AC Loss	Charger AC Loss	Connection from battery cabinet.	DC battery type operators only.
22	Lock Interlock	Lock Interlock	Refer to user relay option 23.	Locking mechanisms.
23	Emergency Close	Emergency Close	Activate with +24. Refer to OC setting in the <i>Table 6: Installer Menu</i> on page 54.	Installer menu enabled and input +24V to trigger. Requires constant hold or supervised input. Overrides photo eyes, gates edges & vehicle detectors.
24	Fire Dept Open	Fire Dept Open	Jumper to +24. See the <i>Table 6: Installer Menu</i> on page 54.	Installer menu FO enabled and input +24V to trigger. Overrides photo eyes and gates edges.

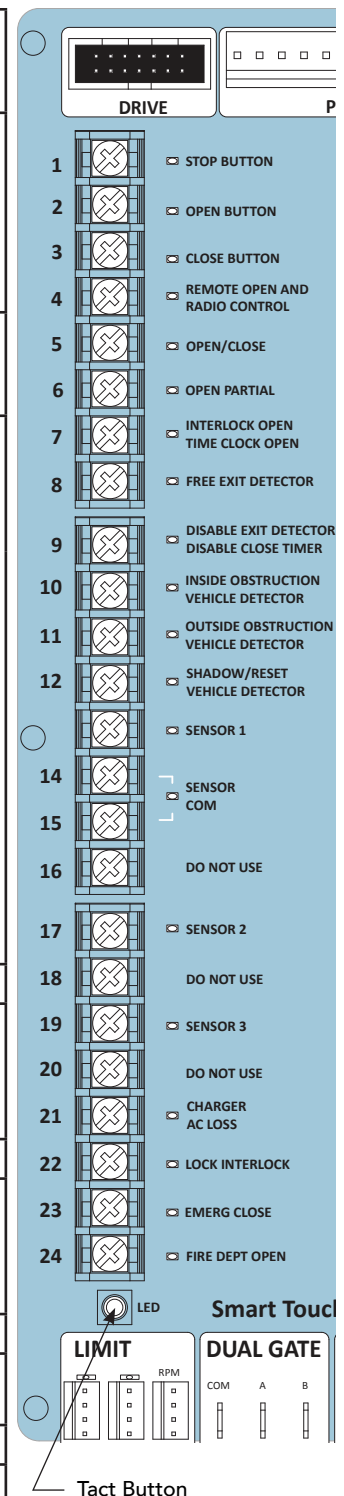

STC Inputs

CONNECTING ACCESSORY DEVICES

Sensors, such as gate edges and photoelectric beams, protect against potential entrapment. These external entrapment protection sensors must be monitored for the gate installation to be in compliance with the 2018 revision to UL 325 Standard of Safety.

NOTE: Always check your local area codes and comply with all regulations.

Other types of accessory connections are shown in the following illustration. All accessories require a minimum of two connections:

- a device input
- a Common Bus Terminal (COM)

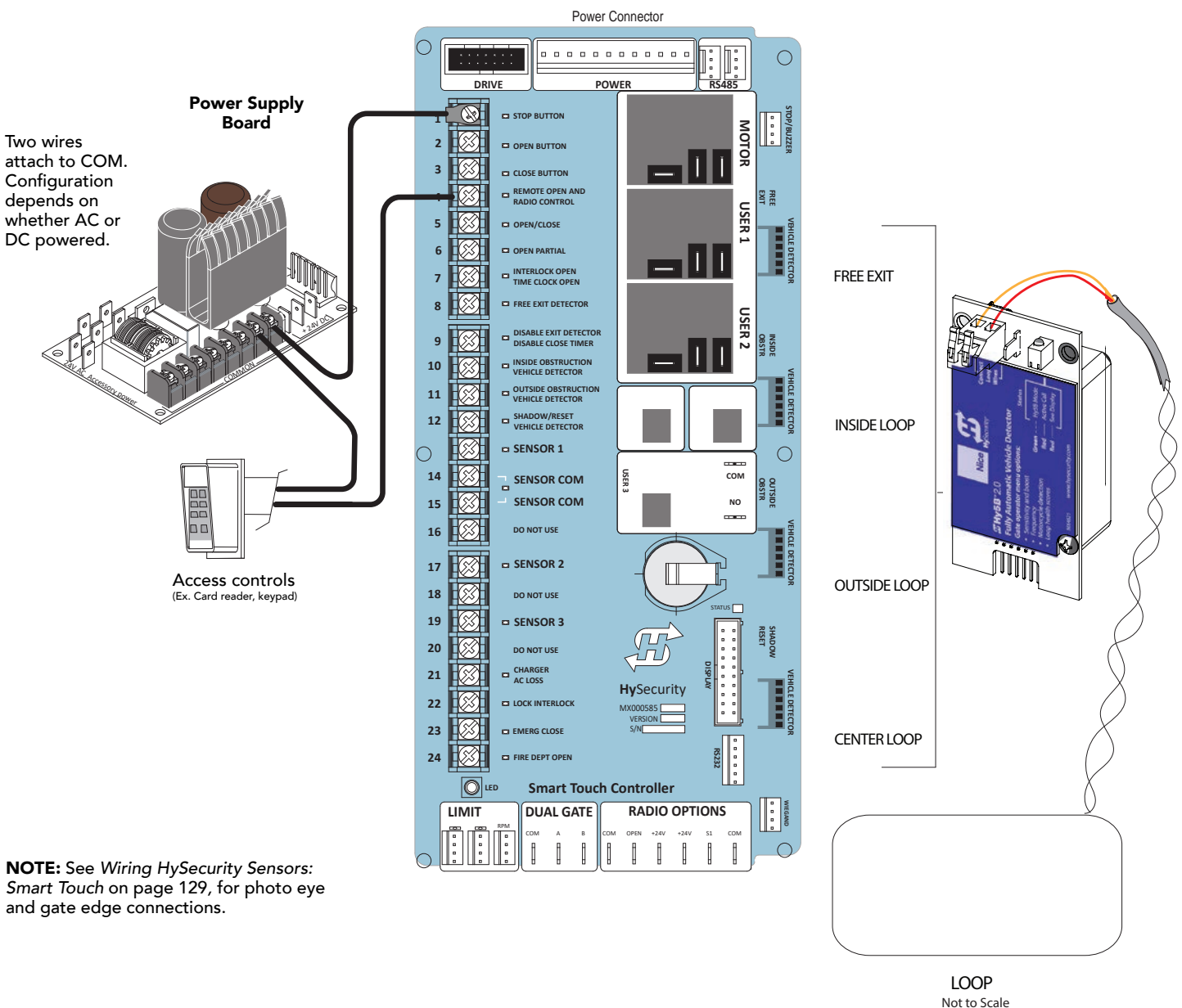

NOTE: See *Wiring HySecurity Sensors: Smart Touch* on page 129, for photo eye and gate edge connections.

USER RELAYS – PROGRAMMING PROCEDURE

The Smart Touch Controller is able to interface with many types of external devices through the use of three user programmable output relays: two mechanical relays (User Relay 1 and User Relay 2), and one solid state relay (User 3) which is used most often for connection to flashing devices.

All of the user relay functions identified and described in the table below are accessible in the Installer Menu (R1 x, R2 x, R3 x) selections.

NOTE: A setting of zero disables a User Relay. The User Relays will operate normally to 18VDC. Below 18VDC, alert notification occurs. On Crash products User 3 relay is unavailable. It is pre-wired for the LED lights.

Use the STC buttons to program the user relays according to the following steps:

1. Select the relay you wish to use through the Installer Menu. See "Table 6: Installer Menu" on page 54. For example: R1 13 (RELAY LOGIC 1) or R2 15 (RELAY LOGIC 2).
2. Select the appropriate function (1 through 33) by changing the display to the associated number listed in the table. Use the Select, Next and Previous buttons to make your selection. Refer to *Menu Mode Navigation* on page 47.

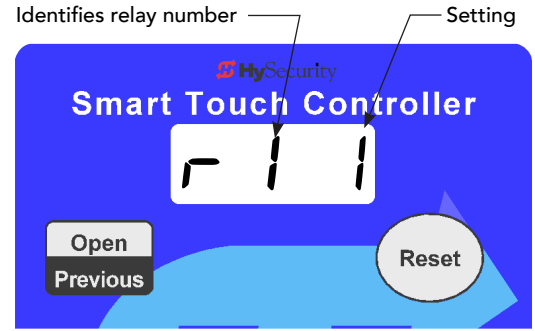

STC display (7-segment)

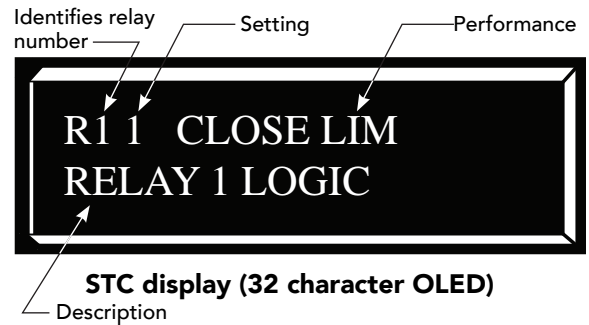

STC display (32 character OLED)

Table 7: Programmable User Relays

Setting	Performance	Description	Wire Connection
1	Close limit output	Creates an interlock signal to another operator's interlock input, or simply to indicate that gate is secure or not. Relay is released when fully-closed limit switch is tripped. Relay is energized when fully-closed limit is released. (Any open command energizes relay.)	Relay 1, 2 or 3
2	Close limit pulse output	Used in a sequenced system to command a second machine to close. Generates a brief pulsed output that occurs when close limit is triggered.	Relay 1, 2 or 3
3	Open limit output	Indicates gate is at full-open position. Output becomes active when an open-limit is triggered and deactivates when open-limit is released or a close command is received. Use this output for a traffic light.	Relay 1, 2 or 3
4	Open limit pulse output	Triggers a sequenced barrier arm gate operator to open. Generates a brief pulsed-output when open-limit is triggered. An additional pulse is also generated with any new open command even when gate is already fully-opened.	Relay 1, 2 or 3
5	Warn before/during operate output	Controls an external warning device. This output is active whenever internal warn before operate buzzer is sounding but the relay output is constant on. Activation timing of this relay is controlled by setting User Menu for Warn Before Operate [bF].	Relay 1, 2 or 3
6	Gate Lock output	Controls external solenoid locks or magnetic locks. In both directions of travel, this output is activated about 7/10ths of a second before operator starts moving the gate.	Relay 1, 2 or 3
7	Gate forced open output	Activated if gate is forced off closed limit switch and operator is not able to restore gate to full closed position within four seconds. The buzzer resets itself in 30 seconds but relay stays active until gate receives a run command.	Relay 1, 2 or 3
8	Gate open too long output	Activates when gate is open longer than the user-selected period of time. Adjustable from a 0 second to 135 seconds delay in 15-second increments. NOTE: TL - Open TIME ALERT adjustments can be made in the Installer Menu.	Relay 1, 2 or 3
9	Safety Mode Alert output	Activated when system is in Safety Mode or Entrapment Mode. Safety Mode occurs upon an impact with an obstruction. Entrapment Mode means gate is stopped and occurs if inherent entrapment sensor triggers while system is in Safety Mode.	Relay 1, 2 or 3
10	Entrapment Mode Alert output	Activated only when system is in Entrapment Mode.	Relay 1, 2 or 3
11	Unauthorized Vehicle Entry output (Tailgate alert)	Activated when a second vehicle enters from outside without a valid input from an access control device. The OOLD and IOLD loops must be capable of being triggered at the same time for this relay to ever activate. This output releases when an access control input signals open or gate reaches the close limit position.	Relay 1, 2 or 3
12	Outside Obstruction Vehicle Detector output	This output is active whenever Outside Obstruction Loop Detector is tripped. Interlocks an entry device to prevent pedestrian use.	Relay 1, 2 or 3

Setting	Performance	Description	Wire Connection
13	Loitering Alert	Indicates vehicle is loitering on Outside Obstruction Loop with the gate closed. Adjustable from a 0 second to 135 second delay in 15-second intervals. NOTE: LT - LOITERING ALERT adjustments can be made in Installer Menu	Relay 1, 2 or 3
14	Gate nearing full travel output (Nearing Limit)	Activated when gate is approaching full open or full closed. Relay activates three feet from where software expects limit switch to be triggered whether moving toward full open, full close, or in a reverse travel mode.	Relay 1, 2 or 3
15	Gate failure output (Fault mode alert)	Activated to report occurrence of problem. Indicates the system is in an Error, Fault, Alert, or Entrapment Mode. If active, gate is disabled.	Relay 1, 2 or 3
16	Motor Running output	Active when motor is running and gate is in motion.	Relay 1, 2 or 3
17	AC Power Failure output	This relay is normally energized and drops with loss of AC power.	Relay 1, 2 or 3
18	DC Power Failure output (Low battery alert)	Activated when battery power is very low, but output ceases when battery is dead (18 volts). Relay is triggered when battery is less than 21 volts.	Relay 1, 2 or 3
19	Flasher Relay	Controls flashing lights to pulse once per second. Relay is constantly pulsing except when open limit switch is triggered. Recommended to use User Relay 3 since it is an electronic relay	Relay 1 or 2* (Relay 3)
20	Free Exit Loop Vehicle Detector output	Active whenever Exit Loop is tripped.	Relay 1, 2 or 3
21	Inside Obstruction Vehicle Detector output	Active when the Inside Obstruction loops is tripped.	Relay 1, 2 or 3
22	Center Loop Detector output	Active when the Reset/Center/Shadow loop detector is tripped.	Relay 1, 2 or 3
23	External Latching gate Lock Output (Prison Lock)	Activates when the Lock Interlock Input (Terminal No. 22) is active at the start of an Open cycle and remains on until the Lock Interlock releases or 10 seconds elapse, whichever happens sooner. Also, activates a Close cycle and releases 1 second after reaching the Close limit.	Relay 1, 2 or 3
24	Gate at Partial Open Position	Active when partial open position is reached or exceeded.	Relay 1, 2 or 3
25	DC Power OK Alert Battery OK Alert	Active when on AC power or the battery voltage is above 21V. When used with User Relay 2, this option can shed electrical loads to conserve battery energy.	Relay 3
26	Free Exit Vehicle Detector Pulse	Outputs a 250ms pulse when the free exit vehicle detector is tripped.	Relay 1, 2 or 3
27	Not Open (requires AC power)	Activated when gate is not on open limit and AC power is present. Deactivated when AC power fails or gate is on open limit.	Relay 1, 2 or 3
28	Flasher (requires AC power)	Output identical to relay #19 and pulses relay 500 ms/sec when gate not on open limit and AC power is present. Deactivated when AC power fails or gate is on open limit.	Relay 1, 2 or 3
41	Test Open Pulse	Output pulses five seconds after close limit is activated. Typically used for cycle testing.	N/A
42	Break-Away Switch Output	Activates when arm break-away switch is tripped.	N/A
43	Warn Before	Combination of relays #5 and #16.	N/A

Setting	Performance	Description	Wire Connection
44	Partial Open Limit Pulse	Pulses for 250ms when gate, commanded with Partial Open input, reaches Partial Open Limit, or, gate is past Partial Open Limit and Partial Open input is activated.	N/A
45	Outside Obstruction/Arming Loop Detector	Activated when OOLD/OALD detector input tripped and gate closed. Used for testing purposes.	N/A

Hy8RELAY MODULE OPTION

The Hy8Relay (extended relay module) provides 8 numbered mechanical relays. R 4, RELAY 4 LOGIC through RB, RELAY 11 LOGIC can be accessed through the Installer Menu. Set the number for the relay based on the information found in *Table 7: Programmable User Relays*.

Wire communication cable connections between the DUAL GATE ports, at the base of the STC, and the extended mechanical relay module. Refer to instructions that accompany the Hy8Relay Module.

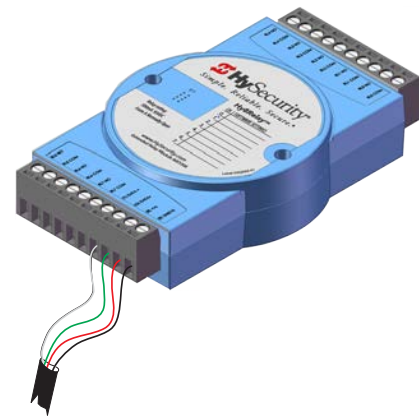

Bi-Parting & Dual Gate Systems

Configuring two operators to be a Primary and Secondary pair is easy with the Smart Touch Controller (STC). There is no need to order a special model or any adapters. The area of the board marked Dual Gate employs a 3-wire, RS-485 serial port for communication between primary and secondary operators.

NOTE: RS-485 communication is available for networked security systems. For additional information, refer to *Connecting Sequenced Gates on page 79*. The HydraSwing Twin is comprised of two gates run with one motor and one Smart Touch Controller. HydraSwing Twin models are categorized as singular systems, not dual gate systems.

CONNECTING AN INTERLOCKED PAIR (DUAL GATE)

The Smart Touch Controller provides dual gate connections (two swing gates run by two separate HydraSupply control units). The STC programming features connect a pair of gate operators in a Primary/Secondary or interlocked Sally Port configuration. The software establishes the communication protocols when wiring the two separate gate operators. A Primary/Secondary pair of operators can be set for different open/close timing sequences (leaf delay feature) and Sally Port gates are often used at correctional facilities. In Sally Port configurations, one operator cannot open unless the other is fully closed. To learn how to connect the wiring between operators, review the wiring diagram on the next page.

NOTE: Both HydraSwing gate systems need to have compatible software versions installed on their Smart Touch Controllers.



HydraSwing 80F Dual Gate Systems

Dual Gate Wiring Connections

To connect an interlocked pair of gate operators, simply follow the steps below.

1. As shown in the Wire Diagram, connect a shielded communications cable to the DUAL GATE inputs in each operator. The inputs are located near the base of the Smart Touch Controller. Be sure to connect the wires in pairs to the same terminal ports (A-A, B-B, COM-COM) on both operators.
2. Attach a ring terminal to the shield wire and connect it to the Smart Touch Controller's convenient ground screw.



Connect the ground shield wire to only one operator, not both. Use only 18-20 gauge twisted and shielded wire. Dual Gate wiring requires 3 wires. HySecurity recommends using a 2-pair, twisted, shielded cable with one pair of wires used to connect A-A and B-B terminals between the two boards. The other pair will connect the Common terminals. The shield should then be grounded on one end to one of the operators. To operate properly, both Smart Touch Controllers must be using the same software version.

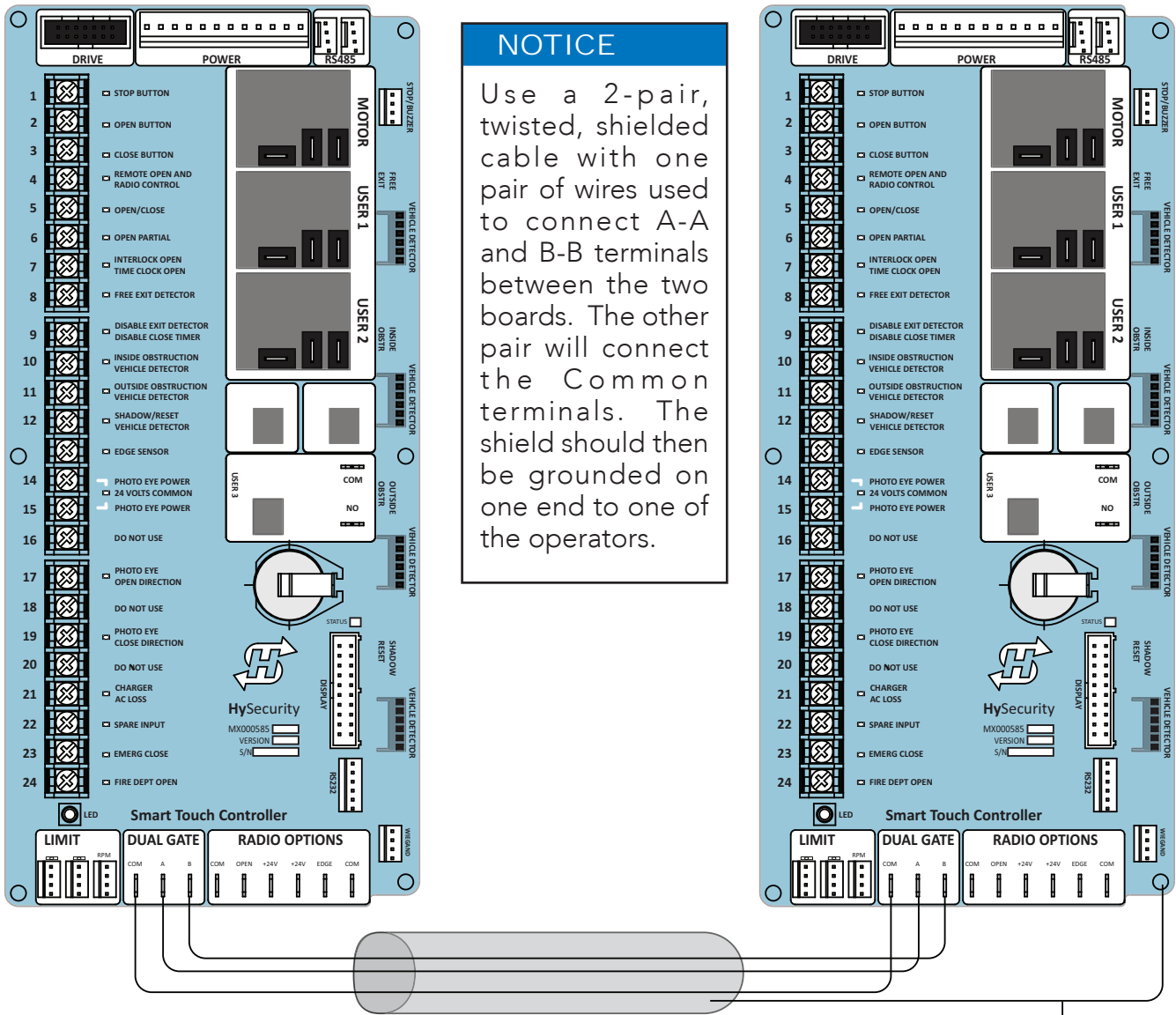

Wire Diagram: Interlocked Pair of Operators wired to DUAL GATE Inputs

Dual or Sequenced Gates: Power, Software & Accessory Requirements

When installing an interlocked pair, the following must be adhered to:

- An electrical conduit for interconnecting wires must span between the two operators. The interlock (dual gate) communication wires and any low voltage control wires must be installed in a conduit that is separate from the high voltage power cables.
- Complete the installation of both operators as separate machines and verify that their basic functions are correct as solo operators before interconnecting them.
- Be sure both operators are running the same software. The software version can be viewed on the display by pressing the RESET button.
- For up-to-date features, keep the most current software loaded on both gate operators. Software downloads are available at www.hysecurity.com. Make it part of your maintenance routine to check for and install software updates on a regular basis.
- External control inputs (vehicle detectors and external entrapment protection sensors) may be connected to either gate operator in a Primary/Secondary configuration, but in a Sally Port configuration, the external control inputs must be connected to each controller as only one gate is allowed to be off the open limit at a time.
- Both operators can not be connected to the same 20A circuit breaker in the main panel. The wire size affects operator performance. Use the following chart as a guideline to size wire for the given distance from the power source to BOTH operators.

NOTE: If using the Hy8Relay, connect it to the dual gate spades on the Primary controller.

Programming a Dual Gate (Interlocked Pair)

Both gate operators must be programmed so they know what function they are to perform as Primary and Secondary or Sally Port A and Sally Port B. (Sally Port A being the first gate to open for incoming traffic.) The Installer Menu provides the Dual Gate (DG) menu item that sets up the functionality of the gate operators. Access this menu item by taking the following steps:

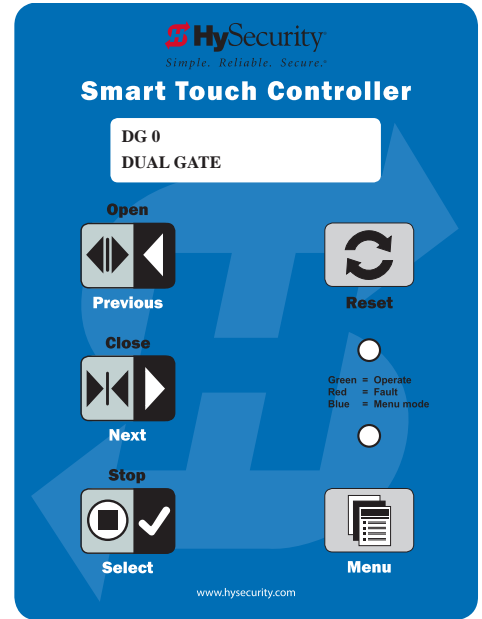
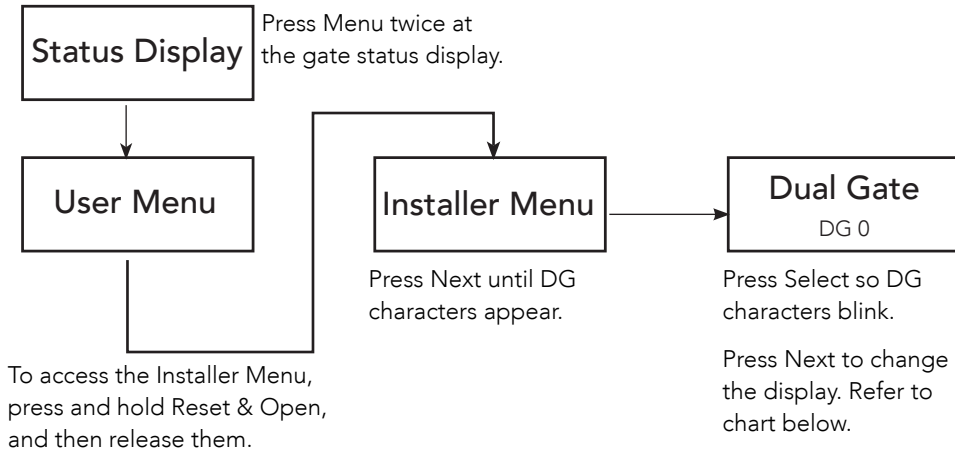

Refer to the chart below to set the operator's functionality.**

**Interlocked Gate type	Operator 1 (Primary)	Operator 2 (Secondary)
Sally Port	<ol style="list-style-type: none"> 1. Press Next until DG 3 appears on the display. 2. Press Select to establish the operator as Sally Port A. 	<ol style="list-style-type: none"> 1. Press Next until DG 4 appears on the display. 2. Press Select to establish the operator as Sally Port B.
Primary / Secondary	<ol style="list-style-type: none"> 1. Press Next until DG 2 appears on the display. 2. Press Select to establish the operator as Primary. 	<ol style="list-style-type: none"> 1. Press Next until DG 1 appears on the display. 2. Press Select to establish the operator as Secondary.

CONNECTING SEQUENCED GATES

Sequenced gates are slightly different than dual or interlocked gates. When two gate operators are connected as sequenced gates, a faster “Traffic Control Gate” operator (i.e. barrier arm or crash wedge) and a slower “Security Gate” operator (slide, swing, or vertical lift gate) operate in sequence to help prevent tailgating or unauthorized entry. Both operators open (Security Gate first followed by the Traffic Control Gate) and allow a vehicle through, but the faster moving Traffic Control Gate closes quickly once its reset/center loop and all obstruction loops are cleared. Upon reaching its closed limit, the Traffic Control Gate signals the Security Gate to close. Note that all shared vehicle detector loops must be cleared before the Security Gate closes.

NOTE: An emergency open or close overrides the gate sequencing and acts upon both gates simultaneously.

The Smart Touch Controller (STC) provides the sequenced gate connections and programming features, and the STC software establishes the communication protocols when wiring the sequenced gate operators. To learn how to connect the wiring between operators, review the Wire Diagram below.



The operators do not have to be of the same type, but both need to have identical software versions installed on the Smart Touch Controller. For example, a StrongArmCrash M30 can be sequenced with a security gate to provide both personnel security and crash provisions. The inherent STC software integrates seamlessly between operators and software protocols and allows RS-485 communication for networked security systems. Refer to *Integrating with Security Systems and HyNet™ Gateway* on page 67 for additional information.

To connect a sequenced pair of gate operators, follow the steps on the next page.

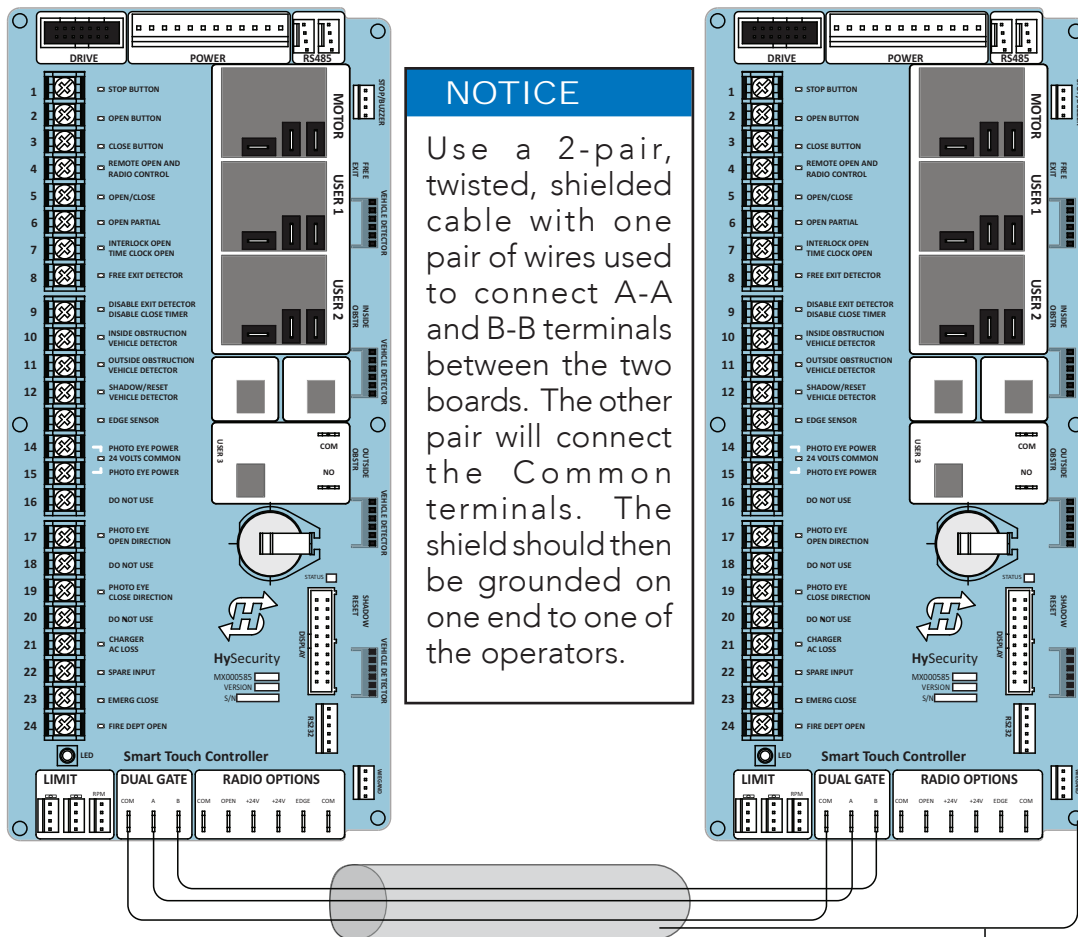

Wire Diagram: Sequenced Pair of Operators wired to DUAL GATE Inputs

1. As shown in the wire diagram on page 79, connect a shielded communications cable to the DUAL GATE inputs in each operator. The inputs are located near the base of the Smart Touch Controller. Be sure to connect the wires in pairs to the same terminal ports (A-A, B-B, COM-COM) on both operators.
2. Attach a ring terminal to the shield wire and connect it to the Smart Touch Controller's convenient ground screw.

NOTE: Connect the ground shield wire to only one operator, not both. Use only 18-20 gauge twisted and shielded wire. Dual Gate wiring requires 3 wires. HySecurity recommends using a 2-pair, twisted, shielded cable with one pair of wires used to connect A-A and B-B terminals between the two boards. The other pair will connect the Common terminals. The shield should then be grounded on one end to one of the operators.

Sequenced gates are very similar to dual gates (interlocked pair) in their Power, Software, and Accessory Requirements. To review the installation site requirements, refer to *Bi-Parting & Dual Gate Systems* on page 75.

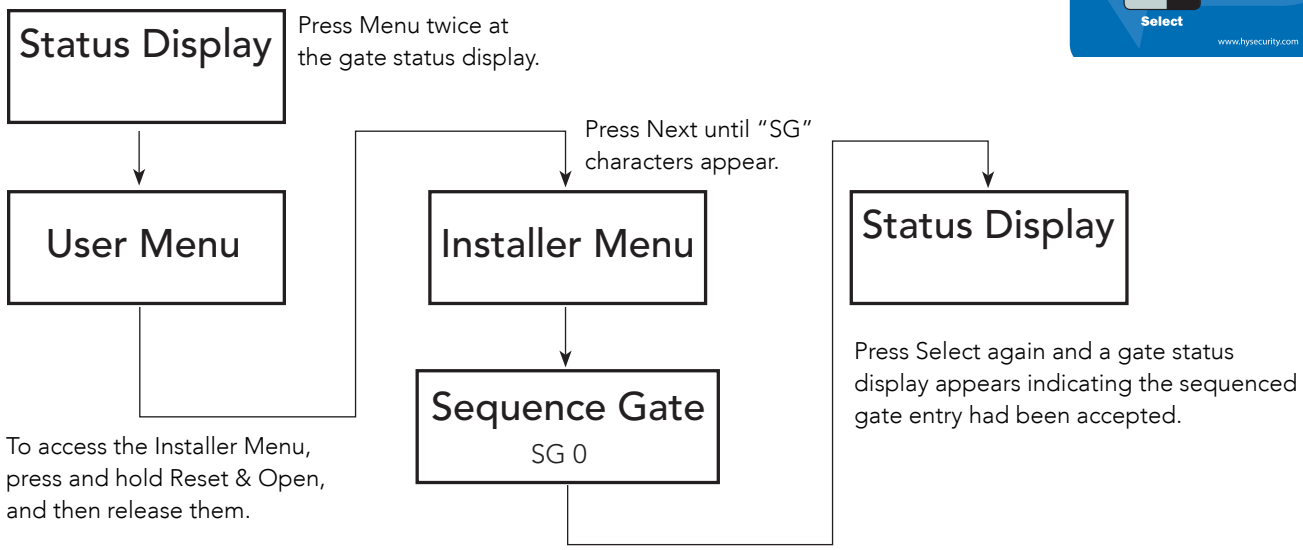
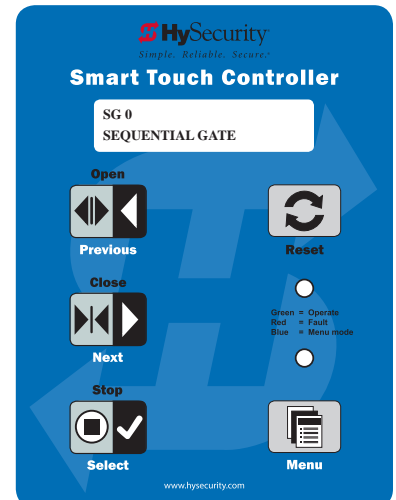

Press Select so "SG" characters blink.

Press Next to change the display:

SG 1 = Sequenced Gate #1 configuration

SG 2 = Sequenced Gate #2 configuration

SG 3 = Sequenced Gate #3 configuration (only used with HydraSupply XL)

SG 4 = Sequenced Gate #4 configuration (only used with HydraSupply XL)

Press Select again and a gate status display appears indicating the sequenced gate entry had been accepted.

NOTE: Set gate operators on the site to the uniquely paired number. Refer to the site designs on the following pages.

DUAL GATE SYNCHRONIZATION

CYLINDER FULL EXTENSION AT CLOSE:

- It is recommended the actuator be tack welded or bolted initially in order to allow easier remounting if required during installation
- The actuator must be installed so that both cylinders are fully extended at the close limit. The position and measurement can be checked by hand pumping the gate closed until the cylinder stops.
- When fully extended, the shiny chrome part of the actuator cylinder should be extended 14" on both gates. See The dimensions in the installation instructions for reference.
- Small adjustments may be made by loosening the clevis on the cylinder, by either threading or unthreading to change the gate position. The intended adjustment is +/- .25". If more adjustment is needed, then the actuator must be remounted.
- After above conditions have been met, ensure the actuator is affixed for operation in a secure manner.

BRAKE VALVES:

There are two brake valves on each actuator. Adjust as follows:

1. The initial adjustment is two (2) turns counterclockwise on all except the furthest close brake valve (or the close brake without a sensor). In rare cases, the sensor cylinder is on the far side, and then the brakes need to be the same or the near side needs to be adjusted for less brake.
2. The furthest close brake valve is set to 1.75 turns counterclockwise. This is done by loosening the 9/16" lock nut and gently turning the 5/32 hex key all the way clockwise, then next turning counterclockwise while counting the turns. The goal is to make the gate furthest from the HydraSupply slightly faster.
3. If a tighter break (more turns counterclockwise) is required to hold against windy conditions, then adjust all brake valves out an equal amount.
4. The furthest close brake is adjusted slightly ¼ turns less than the others. This adjustment can vary depending on hose length.

BLEEDING AIR TRAPPED IN LINES OR CYLINDER:



SECURE THE AREA TO PREVENT A CAR OR PERSON FROM GETTING STRUCK BY THE GATE! THE GATE MUST BE OBSERVED AT ALL TIMES DURING THIS PROCEDURE.

Air can enter the system if the manual release is used and the gate is moved too fast, which is far more likely to happen when pushed closed (extended). It can be done by hand pumping, but this is a slow process. This is also problem when purchasing uncharged hoses, or if the pump pack runs too low on fluid. To bleed air trapped in lines or cylinder, proceed as follows:

1. Run the gate to the full closed position. .
2. Engage the manual release on both operators.
3. Use the installer menu learn limit to reset limits. Use push and hold to drive the gate in the close direction. It should not move, but it will recirculate fluid through the hoses. It will take resetting the error code several times to achieve 30 to 60 seconds of run time.
4. Disengage the manual release levers and run the gate open and close. This can be done in Learn Limit mode.
5. If the gate moves without much manual effort, then repeat the process.
6. Set the limits for open and close, then return to operation.
7. Run the gate 10-20 times to observe normal operation.

TWIN HYDRASWINGS

A hydraulic splitter is used in twin HydraSwing models since only one HydraSupply controls two gates.

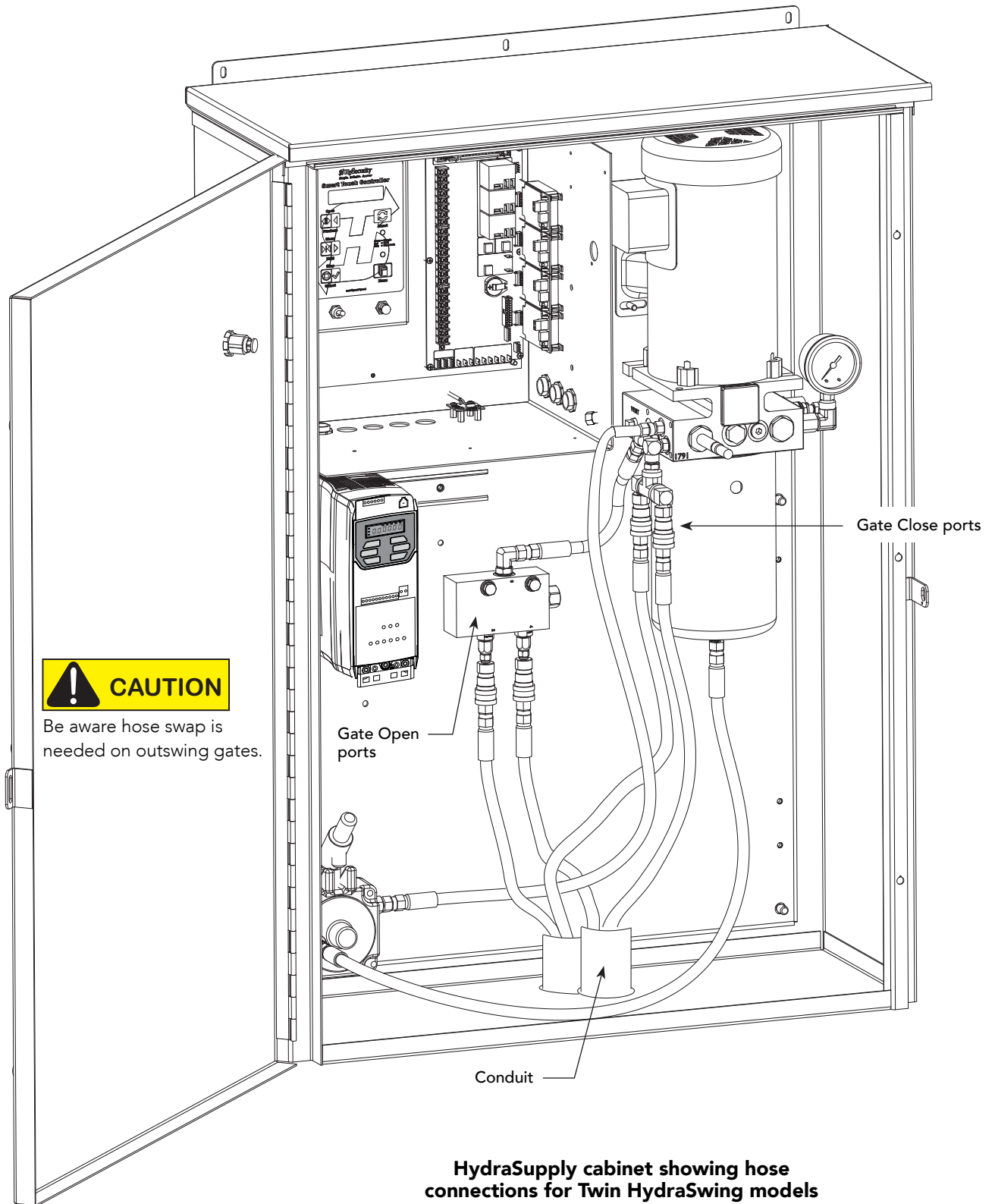

SEQUENCED GATE: CONFIGURATION #1

Vehicle Loop Layout

HydraSwing with StrongArm M30

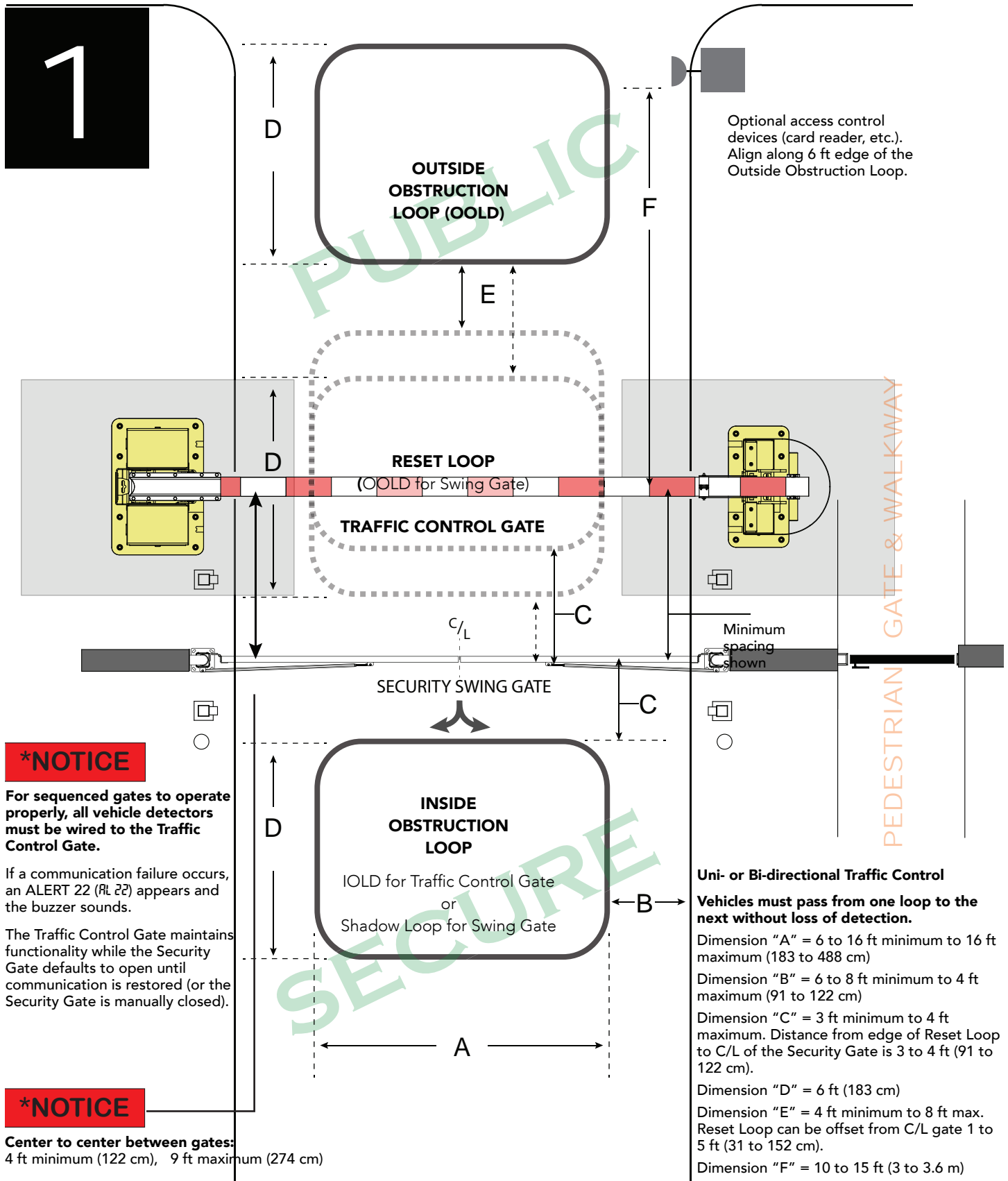

Optional access control devices (card reader, etc.). Align along 6 ft edge of the Outside Obstruction Loop.

PEDESTRIAN GATE & WALKWAY

***NOTICE**

For sequenced gates to operate properly, all vehicle detectors must be wired to the Traffic Control Gate.

If a communication failure occurs, an ALERT 22 (AL 22) appears and the buzzer sounds.

The Traffic Control Gate maintains functionality while the Security Gate defaults to open until communication is restored (or the Security Gate is manually closed).

***NOTICE**

Center to center between gates: 4 ft minimum (122 cm), 9 ft maximum (274 cm)

Uni- or Bi-directional Traffic Control
Vehicles must pass from one loop to the next without loss of detection.
 Dimension "A" = 6 to 16 ft minimum to 16 ft maximum (183 to 488 cm)
 Dimension "B" = 6 to 8 ft minimum to 4 ft maximum (91 to 122 cm)
 Dimension "C" = 3 ft minimum to 4 ft maximum. Distance from edge of Reset Loop to C/L of the Security Gate is 3 to 4 ft (91 to 122 cm).
 Dimension "D" = 6 ft (183 cm)
 Dimension "E" = 4 ft minimum to 8 ft max. Reset Loop can be offset from C/L gate 1 to 5 ft (31 to 152 cm).
 Dimension "F" = 10 to 15 ft (3 to 3.6 m)

SEQUENCED GATE: CONFIGURATION #2

Vehicle Loop Layout

HydraSwing with StrongArm M30

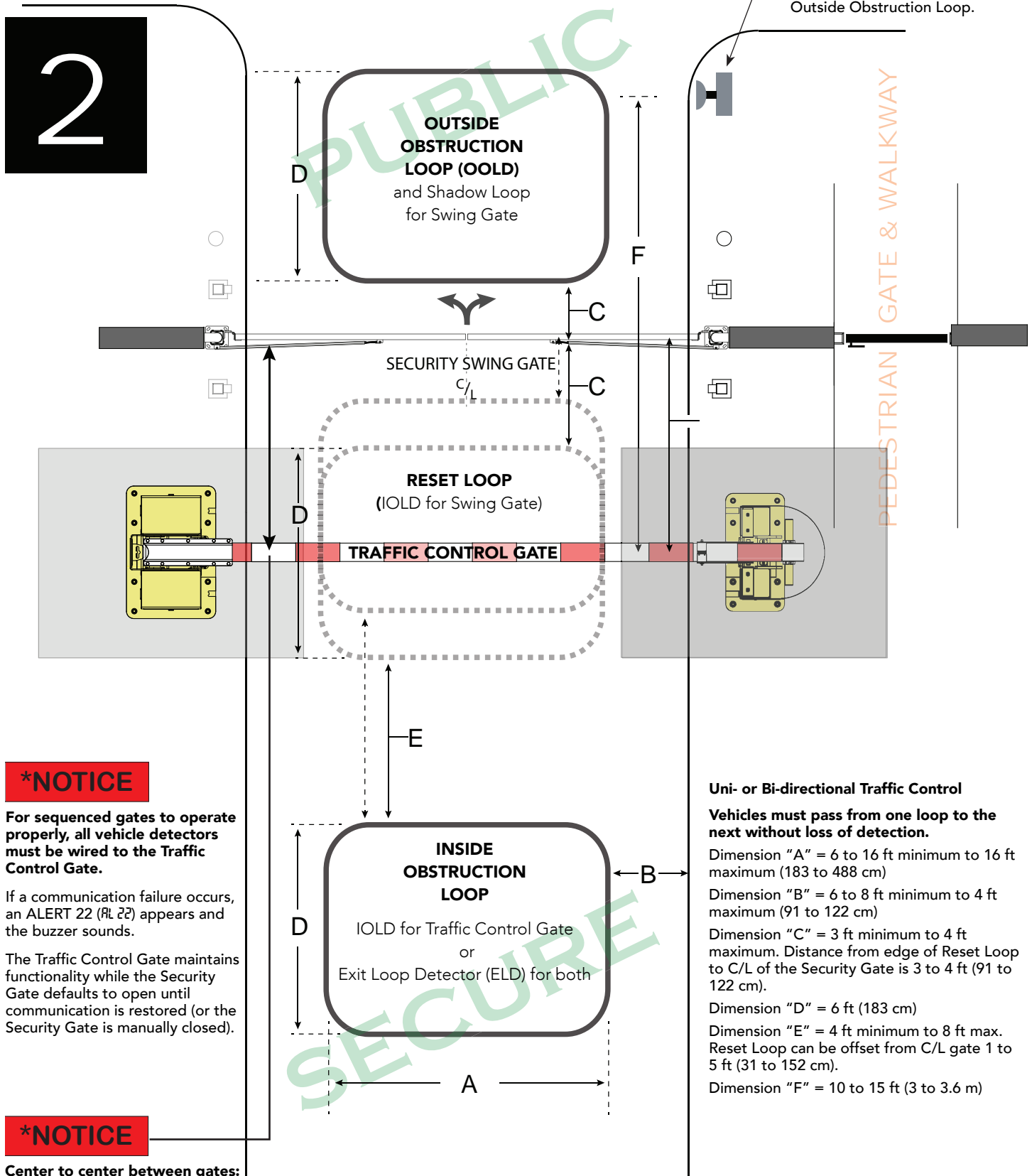

Optional access control devices (card reader, etc.). Align along 6 ft edge of the Outside Obstruction Loop.

2

***NOTICE**

For sequenced gates to operate properly, all vehicle detectors must be wired to the Traffic Control Gate.

If a communication failure occurs, an ALERT 22 (RL 22) appears and the buzzer sounds.

The Traffic Control Gate maintains functionality while the Security Gate defaults to open until communication is restored (or the Security Gate is manually closed).

***NOTICE**

Center to center between gates:
4 ft minimum (122 cm), 9 ft maximum (274 cm)

Uni- or Bi-directional Traffic Control

Vehicles must pass from one loop to the next without loss of detection.

Dimension "A" = 6 to 16 ft minimum to 16 ft maximum (183 to 488 cm)

Dimension "B" = 6 to 8 ft minimum to 4 ft maximum (91 to 122 cm)

Dimension "C" = 3 ft minimum to 4 ft maximum. Distance from edge of Reset Loop to C/L of the Security Gate is 3 to 4 ft (91 to 122 cm).

Dimension "D" = 6 ft (183 cm)

Dimension "E" = 4 ft minimum to 8 ft max. Reset Loop can be offset from C/L gate 1 to 5 ft (31 to 152 cm).

Dimension "F" = 10 to 15 ft (3 to 3.6 m)

Drawings not to scale.

Vehicle Detector Installation and Loop Layouts

HySecurity recommends that vehicle detectors be used for free exit and obstruction sensing logic only. The exception is in parking or barrier arm applications where detectors may also be used to close the gate. In applications employing our swing, vertical lift, or sliding gate operators, closing logic cannot be used except when the anti-tailgate logic is employed.

Vehicle detector functions (OR, IR, HD, DL) are configurable through the *Table 6: Installer Menu* on page 46.

NOTE: For in-depth information regarding Hy5B vehicle detectors, click [Tech Support on the HySecurity website](#) and follow the link to [Installation Manuals](#).

Anti-TailGate Mode (Closing Logic)

The Detector Logic (DL) installer menu item lets you set the anti-tailgate mode. This menu item works in conjunction with the Close Timer (CT) when the vehicle detector is triggered. If you plan to use the anti-tailgate feature, check the time delay aspect of the Close Timer (CL) setting.

The four selectable modes for DL are as follows:

Mode 1 (Default): An input from either the Free Exit, Outside Obstruction Loop (OOLD), Inside Obstruction Loop (IOLD), or the Center Loop (CLD/RESET/Shadow) will hold the gate open, reset the close timer, and ignore all close inputs. The close timer begins to count down only after all vehicle detectors are clear and no other open command is present.

Mode 2: The close timer does not wait for vehicle detectors to clear, but instead it starts counting down as soon as the open limit is reached.

Mode 3: When both inside and outside obstruction loops are simultaneously active, the gate will close immediately (unless another open command is present) once all vehicle detectors are no longer sensing active loops (i.e. vehicle loops are clear).

Mode 4: Full anti-tailgate logic includes Mode 3 functions. In addition, the gate will stop during the opening cycle when both OOLD & IOLD (reversing loops) are tripped simultaneously. When the OOLD & IOLD loops are cleared, the gate closes immediately. The OOLD & IOLD can be individually set so that, if tripped while closing, the gate may either, pause only or reverse to reopen. The free exit detector input is ignored while the gate is closing.

NOTICE: Using any vehicle detector logic mode other than Mode 1 (default) requires that all the loops be placed with the geometry and spacing as shown in the loop layout drawings. The detector Modes 3 and 4 require use of separate inner and outer obstruction detectors. Mode 4 is not available in HydraWedge SM50 or gate operators functioning with HydraSupply XL.

TailGate Alert

User Relay 11 is available for notification devices. If a vehicle is tailgating, and a flasher or audio device is connected to User Relay 11, the relay will be triggered by the tailgating vehicle crossing the loops. Refer to *User Relays – Programming Procedure* on page 63.

VEHICLE DETECTORS AND THE SMART TOUCH CONTROLLER

The Smart Touch Controller provides an interface for up to four different vehicle detector functions.

NOTE: Standard box type 11 pin (24 VDC or 24 VAC) vehicle detectors may be connected in the traditional manner to the controller, but HySecurity Hy5B mini-detector modules plug directly into the board, making field installation much faster and enhancing performance.

The Hy5B detector communicates with the Smart Touch Controller microprocessor to achieve the following benefits:

- **Automatic Sensitivity** – The Hy5B monitors vehicle traffic over the loop and automatically adjusts the loop sensitivity based on vehicle type and volume.
- **Automatic Gate Compensation** – The Hy5B discerns gate travel over the loop and automatically compensates for its effect. The compensation allows the Hy5B to operate with a higher sensitivity which provides better detection capability.
- **No Loop Crosstalk** – Exclusive use of Hy5B vehicle detectors in HySecurity gate operators, completely eliminates crosstalk and the need to set frequency levels.
- **Vehicle Counting** – Hy5B detects passenger vehicles and motorcycles.
- **Automatic Lightning Suppression** - Where lightning strikes occur often, connecting to the ground terminal minimizes the chance of activation or lock-up.
- **Health Scores for Loop** – Hy5B monitors the loop for changes that are indicative of possible problems. A score is accessible through the event log, LG menu item.
- **Automatic Hy5A emulation mode** for backward compatibility.

Hy5B Installation

To install an Hy5B vehicle detector, you will need to take the following steps:

- Test the vehicle loop
- To use all the features of Hy5B, update the software version on the gate operator to the latest version using S.T.A.R.T. and a PC laptop. Access free software updates from the HySecurity website: www.hysecurity.com
- Install the Hy5B vehicle detector
- Fully cycle the gate at least 2 times to allow the detector to adjust to the effects of the gate during travel. Drive a test vehicle over the loops.

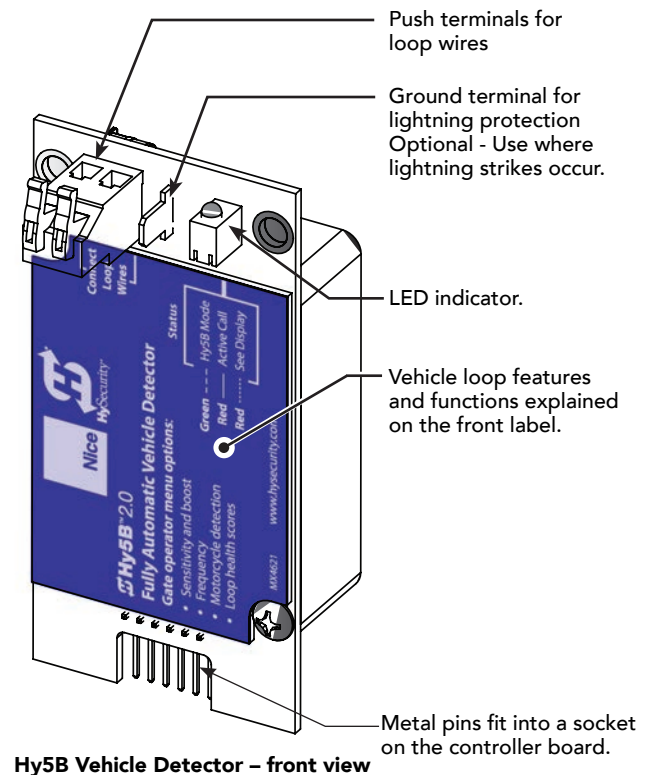

Hy5B Vehicle Detector – front view

Test the Vehicle Loop

Run diagnostic tests on the vehicle loops before installing Hy5B vehicle detectors to ensure the loops are in good working condition. The following tests cannot guarantee a functioning loop, but failure of either test means that the loop may be damaged or need to be replaced.

1. Test – Measure the resistance of the loop and lead-in wire. It should not exceed 4.0 ohms.
2. Test – Measure the resistance to earth ground with a Megohmmeter (Megger). It should be 100 Megohms or more. Below 50 mega-ohms, install a new loop.

NOTE: Loops may function at 100 Megohms or less, but will not be reliable (for example, when the ground is wet from rainfall). A low megohm reading on the resistance to earth ground usually occurs due to broken or moisture saturated insulation. Be sure to use wire with a direct burial jacket such as XLPE or XHHW wire. Do NOT use THHN wire.

Check the Version of Software

1. In the field, open the gate operator's Control Box.
2. To view the software version, press the RESET key. To use Hy5B features, the software version must be h4.55 or h5.56 (or later). Otherwise, the Hy5B reverts to Hy5A emulation mode.
3. If you wish to update the software, download the current S.T.A.R.T. software to your PC laptop, and then load the gate operator code to the controller board before installing Hy5B vehicle detectors. See www.hysecurity.com for updates.



NOTE: Hy5A emulation mode does not include all the features of Hy5B. If you are replacing Hy5A detectors and updating the gate operator software, be aware Build Year will need to be set. BY2 and BY3 requires monitoring of external entrapment protection sensors per UL 325 - 2016 Standard of Safety. If the gate operator was installed prior to 2016, BY1 may be used. For more information, refer to the gate operator's product manual.

Install Hy5B Vehicle Detectors

Install one Hy5B detector at a time. Each vehicle detector socket is labeled.

1. Turn power OFF in control box.
2. Insert the squared-off end of the plastic standoff through the hole in the Hy5B detector.

NOTE: The plastic standoff "squared-off end" does not fit into the mounting holes of the control box. Double check the orientation of squared-off ends.

3. To minimize excessive flexing, keep each Hy5B perpendicular to the control board as you plug it into the Hy5B socket.
4. Secure the Hy5B by inserting each plastic standoff into the chassis.
5. Place the two wires from the loop into the push terminals of the Hy5B. For ease of installation, the wire gauge should be 20 - 14 AWG. Refer to *Vehicle Loop Sets* on page 88.

NOTE: If you have more Hy5B detectors, repeat the steps 2 through 4 for each additional Hy5B detector.

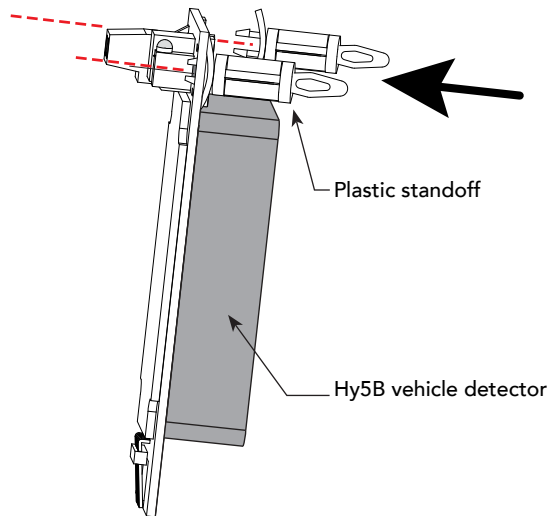
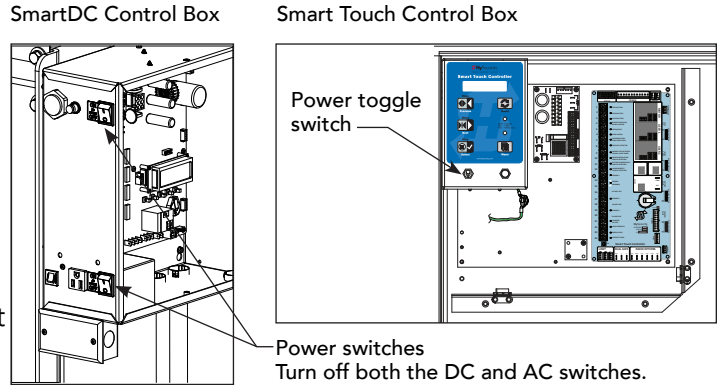

LED Display Status		
LED Activity	Indicates	Condition & Resolution
OFF	Hy5A mode	Emulation mode. Some Hy5B features are unavailable.
GREEN PULSING	Heart beat	Normal operation.
RED ON	Call Mode	Status indicates loop activation in process.
RED FLASHING	View display for more information: <i>Initializing or Faulty loop</i>	If initializing, wait until initialization is complete. If flashing during loop operation, take following steps: 1. Check loop wiring. Refer to <i>Test the Vehicle Loop</i> on page 87. 2. Replace loop. 3. If loop is not at issue, swap out Hy5B vehicle detector with a known operational Hy5B. 4. If necessary, replace Hy5B.

Vehicle Loop Sets				
Loop Type	Installer Menu	Loops Smart DC	Loops Smart Touch	Description
Exit Loop	ELD	EXIT LOOP	FREE EXIT	Opens a fully-closed gate.
Inside Reversing Loop	ILD	INSIDE OBSTRUCTION	INSIDE OBSTR	Connects to the inside reversing loop.
Outside Reversing Loop	OLD	OUTSIDE OBSTRUCTION	OUTSIDE OBSTR	Connects to the outside reversing loop.
Reset/Shadow/Center	SLD/CLD	CENTER LOOP	SHADOW / RESET	Prevents a gate from starting open or closed when a vehicle is in the path of the gate.

5. Turn power to the gate operator back ON.
6. The Hy5B indicator light flashes red and the following appears.

Smart Touch 7-segment Display	STC (OLED) and Smart DC Displays
in it	INITIALIZING

- When the LED on the Hy5B detector stops flashing red, it begins pulsing green which indicates **initialization is complete** and the detector is **ready for use**.

NOTE: If using Hy5A emulation mode, the LED does not flash green, it goes dark. Refer to *LED Display Status* on page 78.

- Press the Reset button. *
When you press Reset, the following occurs:

- Checks Hy5B loop connections and re-tunes Hy5B to prevent crosstalk
- Un-installs memory of vehicle detectors physically removed
- Clears alerts

NOTE: If the Hy5B is unplugged after it is initialized, an alert appears on the display, ALERT 10. If the issue is not resolved, ERROR 3 appears. When faults of this nature occur, the gate operator functions as if the Hy5B is triggered.

NOTE: * Best Practice: When "re-tuning" Hy5B vehicle detectors, verify that the loops are clear before pressing the Reset button.



Do not connect Free Exit loop wires to the same Hy5B detector containing obstruction loop wires (reversing loops). You cannot combine Free Exit vehicle detection with reversing loop detection. If you attempt to do so, vehicles crossing over the Free Exit will not be detected.

For more information, refer to the Hy5B User Guide and additional instructional material found online [HySecurity website / Tech Support](#).

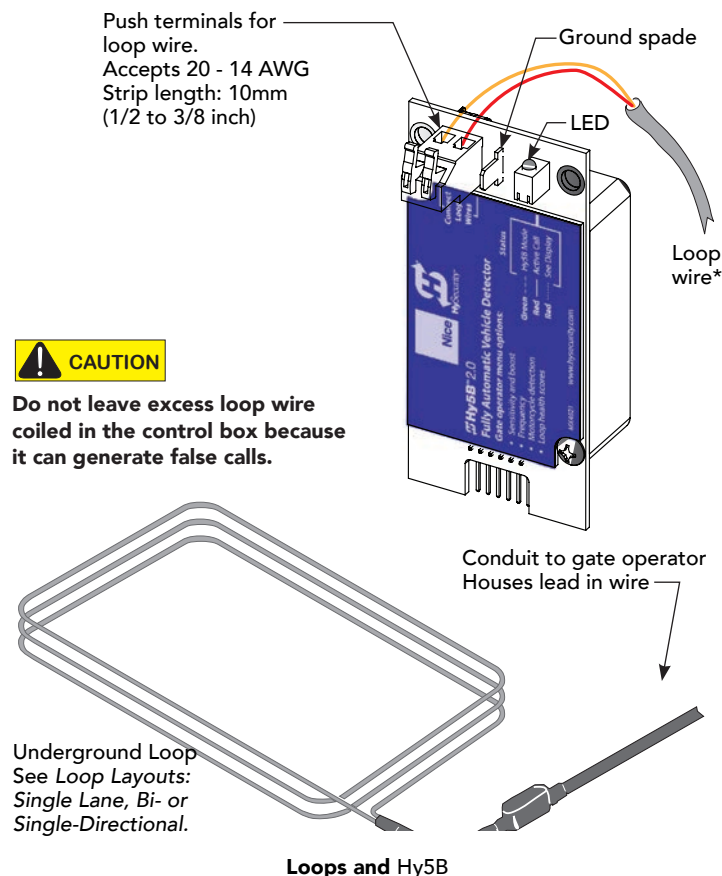

VEHICLE DETECTOR AND LOOP FAULT DIAGNOSTICS

If HySecurity HY-5B vehicle detector modules are used, the Smart DC Controller has the ability to store and report detector and loop fault information for performance diagnostics.

If the Smart DC Controller senses a loop or detector problem:

- The LCD display flashes the name of the affected detector or error and the appropriate alert code.
- The buzzer chirps continuously at regular intervals until the issue is resolved.

HY-5B Vehicle Detector Faults and Errors			
Alert or Error #	LCD Description	Advisory	Resolution
ALERT 7	FREQ SHIFT FAULT	HY-5B vehicle detector - Abnormal frequency change alert.	Alert indicates an unstable loop frequency. Check loop and lead in wires for problems. Replace them, if necessary.
ALERT 8	LOOP SHORTED	HY-5B vehicle detector - Loop is shorted.	Alert indicates that loop and lead in wires are shorting out. Check wires for problems. Replace them, if necessary.
ALERT 9	LOOP OPEN	HY-5B vehicle detector - Disconnected loop alert.	Alert indicates loop wires are loose or disconnected. Check wires for problems. Replace them, if necessary.
ALERT 10	I2C BUS ERROR	HY-5B vehicle detector - Communications alert.	Alert indicates detector is not communicating properly with Smart DC Controller. Alert occurs if detector is unplugged or connection is unstable. If communication is not reestablished within 30 seconds, controller will reset and message changes to ERROR 3.
ALERT 11	DETECTOR FAULT	HY-5B vehicle detector - Malfunction alert.	Display indicates HY-5B detector malfunction. Check detector for problems. Replace it, if necessary.
ALERT 12	ON TOO LONG	Detector input triggered too long - More than five minutes.	Display indicates HY-5B detector malfunction. It alert also works for any input connected to terminal strip for standard box detectors. Check that a vehicle is not parked on loop. Also, determine if loop is stable. An unstable loop can hold detector in a triggered state.
ERROR 3	DETECTOR FAILED	HY-5B vehicle detector - Communication failed. Smart DC Controller will behave as if detector is triggered, usually holding gate fully open.	Alert indicates detector is not communicating properly with Smart DC Controller. Alert occurs if detector is unplugged or detector has failed. To replace detector, press RESET button to clear error and re-seat detector or install a new one.

Even if the loop problem self heals, historical data about detector/loop performance and a log of Alerts, Faults and Errors can be retrieved from the Smart Touch Controller by downloading from the RS232 communications port or the USB port. HySecurity's free START software, a laptop computer, and a special download cable or USB cable are required to retrieve and read this data.

Loop Health:

The Hy5B monitors loop health which is comprised of loop noise, loop step changes and loop reference changes. Loop health readings accumulate throughout a 24 hour period and the accrued readings are posted to the Event Log each day at midnight. After midnight, the loop health baseline resets to its highest value of 777.

Example of an Event Log posting:

Event log:
02/09 EVENT - CLD Loop Health: noise 5, step 6, ref 7

Loop Presence:

Loop presence is dependent on “disturbance effect” of the entire vehicle. Presence determines how long to hold the “memory” of a stationary vehicle on a loop before it is forgotten and ignored. Set the presence of the loop:

- LONG (default) lasts about 20 hours dependent on call strength and sensitivity setting. The Hy5B tunes out the “disturbance effect” when a vehicle is stationary on a portion of the loop, but keeps the undisturbed (unaffected) portion of the loop operational.
- INFINITE never drops the call. The INFINITE setting requires a certain amount of signal strength. A “threshold” is maintained and it will hold the call forever. The loop connected to an Hy5B with this setting may become nonfunctioning.

Setting Loop Presence		
Sub-menu Item	Display	Example Site Scenario
PR 0	(LONG)	With sensitivity set to A (AUTO) and a large sedan stationary on loop, LONG presence may hold call for many hours before vehicle’s presence is tuned out. Then, stationary vehicle is ignored and unaffected portion of loop becomes operational. In contrast, with sensitivity set to M (MOTORCYCLE), default threshold only lasts about 1 hour before presence of motorcycle on loop is tuned out.
PR 1	(INFINITE)	A site where standing or parked vehicular traffic (on large area loops) is a daily or consistent basis , INFINITE presence setting is available option. When loop may have vehicles parked on it for more than several hours and it must hold the call, set presence to INFINITE.

NOTICE: Hy5B has ability to continue counting vehicles passing over loop even though a stationary vehicle may be on a portion of loop. Controller and Hy5B detector also exchange pertinent information, so if a power failure were to occur, controller can determine if a vehicle is on loop when power returns.

Frequency:

Knowing the exact frequency of a loop can be useful as a diagnostic tool, and verifying the stability of the loop frequency is valuable information. To view the actual loop frequency of a specific vehicle detector, go to the setting for that detector in the Installer Menu, switch the selection from 0 to 1, and press the Select button. The display will show the loop frequency. The frequency is usually between 20,000 to 80,000 Hertz.

Changing the Loop Frequency:

HY-5B detectors can never crosstalk. If for any reason, you want to manually change the loop frequency, change the Installer Menu option for the desired loop from 0 to 3, and then press the Select button. Each detector has a choice of four frequencies. Press the Select button when the desired frequency setting is found, and the controller will perform a reset and tune to the new frequency setting.

Call Strength Level:

Knowing the call strength of a detector is valuable because it provides information about how well the loop is actually "seeing" a specific vehicle. For example, it may be useful to check to see if the loop is easily detecting the middle of a high bed semi-truck. The strength of a detector call can be displayed in real time, on a scale of 0 to 7. As indicated in the table below, when the Installer Menu setting for a given detector is set to 2, and the Menu button is pressed, the LCD display will read Level 0 - 7 Call Level. If the call strength on the display appears as a level 4 or less, consider increasing the sensitivity level by adjusting the rotary switch on the HY-5B detector.

HY-5B Vehicle Detector Call Level Display			
Installer Menu	LCD Description	Setting Options (Bold = Factory Settings)	
ELD 0	EXIT LOOP SET	0 = Run mode	5 = Set Sensitivity
ILD 0	IN OBS LOOP SET	1 = Show frequency	6 = Show Inductance
OLD 0	OUT OBS LOOP SET	2 = Show call level 0-7	7 = Show Loop Health
CLD 0	CENTER LOOP SET (Can be used as an arming loop with User Relay 22.)	3 = Set Frequency	8 = Set Presence
		4 = Show Sensitivity	

INSTALLING STANDARD 11-PIN BOX TYPE VEHICLE DETECTORS

If standard 11-pin box type vehicle detectors are to be used, perform the following procedure.

If there is sufficient space, install the sockets in the control box; if not, then install them in a separate external housing. Carefully consider your peripheral connections. Any peripheral device required for safe gate operation should be attached to 24VDC in case of an AC power outage.

NOTE: Box detectors with relays require five times more power than Hy5x detectors. One Hy5x detector draws about 0.005A. Consider Hy5x vehicle detectors for DC and Solar powered sites.

1. Connect 24 Volt power to the detector. Connect Pin No. 1 to a 24VAC or 24VDC terminal and Pin No. 2 to common.
2. Connect output Pin No. 6 to the Common Bus and output Pin No. 5 to one of the four detector terminal inputs (depending upon the detector function required) on the Smart Touch Controller.

If multiple detectors are used, route the power wires and common wire from socket to socket (daisy-chaining) rather than individually running each wire to the same location. The only wires that are separate are the output wire to the Smart Touch Controller and the detector loop input wires.

Always keep the detector loop wires well twisted beyond the area of the loop. The lead in portion sealed in a saw cut does not need to be twisted so long as the wires are encapsulated in loop sealant and cannot move.

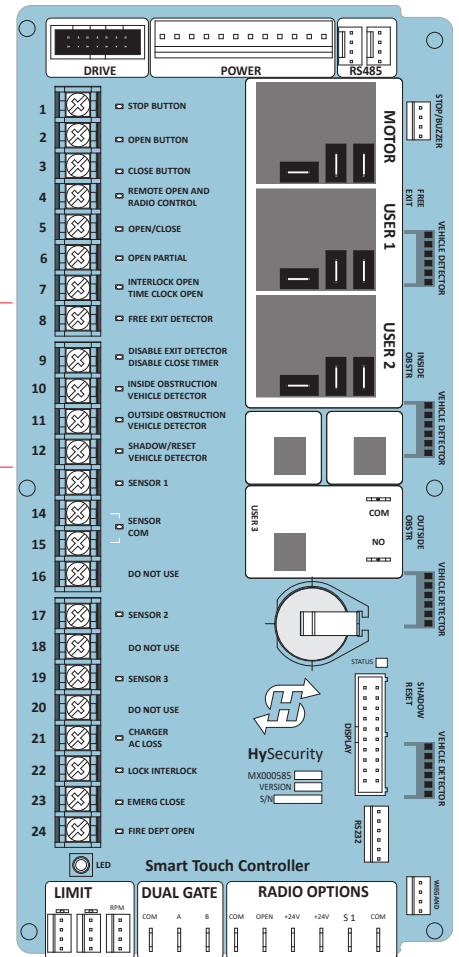
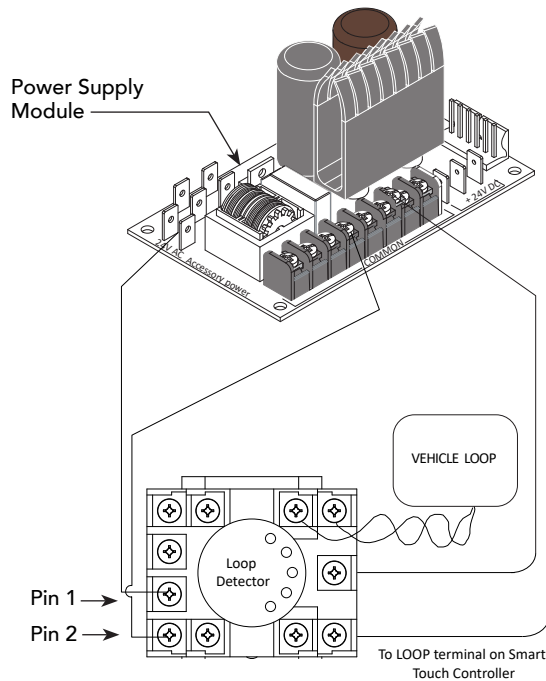

Match detector connection to its voltage rating (24VAC or 24VDC).

NOTE: Both 24 Volts AC and DC are available, so either detector voltage may be used. 24 VAC is not available if the Gate Operator is equipped with the UPS option. 24 VAC is available at the spade terminals on the lower left corner of our power supply (marked ACC); 24 VDC is available from the Common and the +24 V spade terminals.

LOOP LAYOUTS: SINGLE LANE, BI- OR SINGLE-DIRECTIONAL

For Openings less than 28 Feet

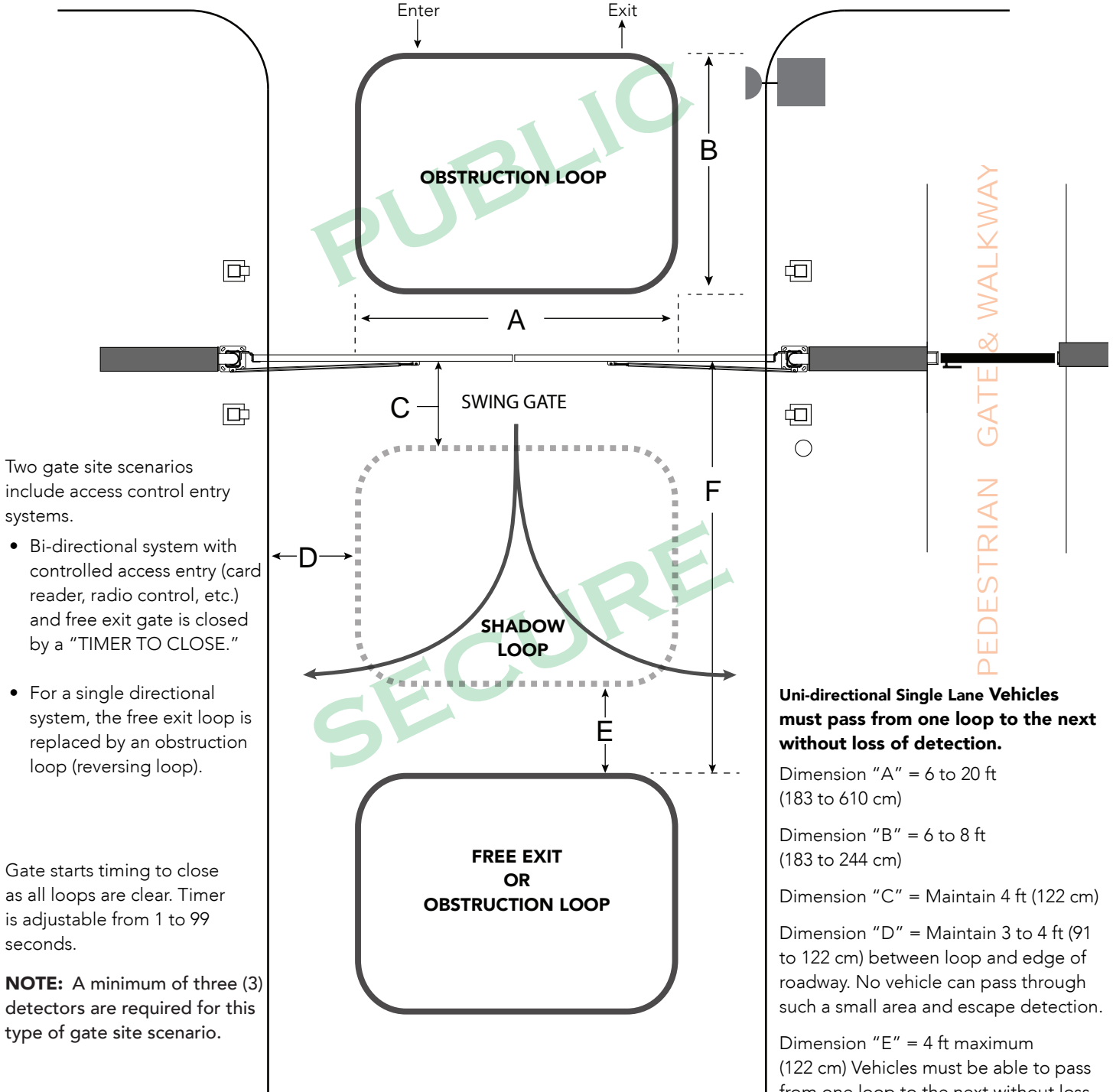

Two gate site scenarios include access control entry systems.

- Bi-directional system with controlled access entry (card reader, radio control, etc.) and free exit gate is closed by a "TIMER TO CLOSE."
- For a single directional system, the free exit loop is replaced by an obstruction loop (reversing loop).

Gate starts timing to close as all loops are clear. Timer is adjustable from 1 to 99 seconds.

NOTE: A minimum of three (3) detectors are required for this type of gate site scenario.

NOTE: A minimum of three (3) detectors are required for this type of gate site scenario.

Uni-directional Single Lane Vehicles must pass from one loop to the next without loss of detection.

Dimension "A" = 6 to 20 ft (183 to 610 cm)

Dimension "B" = 6 to 8 ft (183 to 244 cm)

Dimension "C" = Maintain 4 ft (122 cm)

Dimension "D" = Maintain 3 to 4 ft (91 to 122 cm) between loop and edge of roadway. No vehicle can pass through such a small area and escape detection.

Dimension "E" = 4 ft maximum (122 cm) Vehicles must be able to pass from one loop to the next without loss of detection.

Dimension "F" = Distance from gate to free exit loop is gate panel length plus 4 ft (122 cm)

LOOP LAYOUTS: TWO LANE, BI-DIRECTIONAL

For Openings greater than 28 Feet

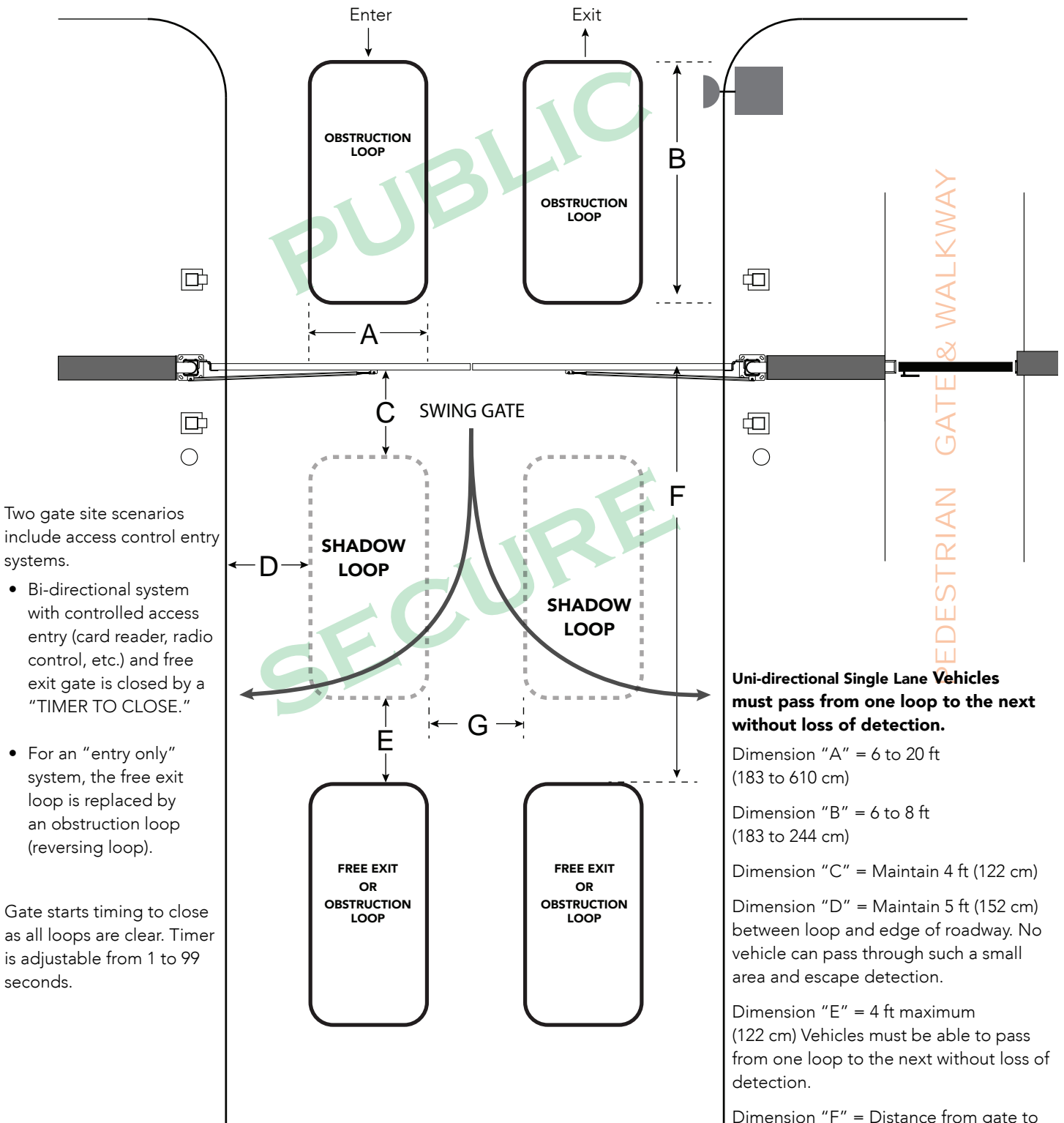

Two gate site scenarios include access control entry systems.

- Bi-directional system with controlled access entry (card reader, radio control, etc.) and free exit gate is closed by a "TIMER TO CLOSE."
- For an "entry only" system, the free exit loop is replaced by an obstruction loop (reversing loop).

Gate starts timing to close as all loops are clear. Timer is adjustable from 1 to 99 seconds.

Uni-directional Single Lane Vehicles must pass from one loop to the next without loss of detection.

Dimension "A" = 6 to 20 ft (183 to 610 cm)

Dimension "B" = 6 to 8 ft (183 to 244 cm)

Dimension "C" = Maintain 4 ft (122 cm)

Dimension "D" = Maintain 5 ft (152 cm) between loop and edge of roadway. No vehicle can pass through such a small area and escape detection.

Dimension "E" = 4 ft maximum (122 cm) Vehicles must be able to pass from one loop to the next without loss of detection.

Dimension "F" = Distance from gate to free exit loop is gate panel length plus 4 ft (122 cm)

Dimension "G" = 4 to 6 ft (122 to 183 cm)

NOTE: A minimum of three (3) detectors are required for this type of gate site scenario.

Photo Eye Installation

A monitored connection tests for the presence and correct operation of the photo eyes (and other monitored sensors) prior to each gate activation. The monitored connection prevents gate operation if an entrapment protection sensor is missing or any fault is present.

Sensors, such as gate edges and photoelectric beams, must be installed to protect against entrapment. These external entrapment protection sensors are required for the gate installation to be in compliance with the 2018, UL 325 Standard of Safety (7th Edition).

NOTICE: UL 325 Standard of Safety provides the MINIMUM safety standards. Site, gate hardware usage, and other conditions may dictate the use of additional safety designs/components. It is up to the gate system designer and installer to assess appropriate safety design and components above and beyond minimum UL 325 and ASTM F2200 Standard of Safety. Always check your local area codes and comply with all regulations.

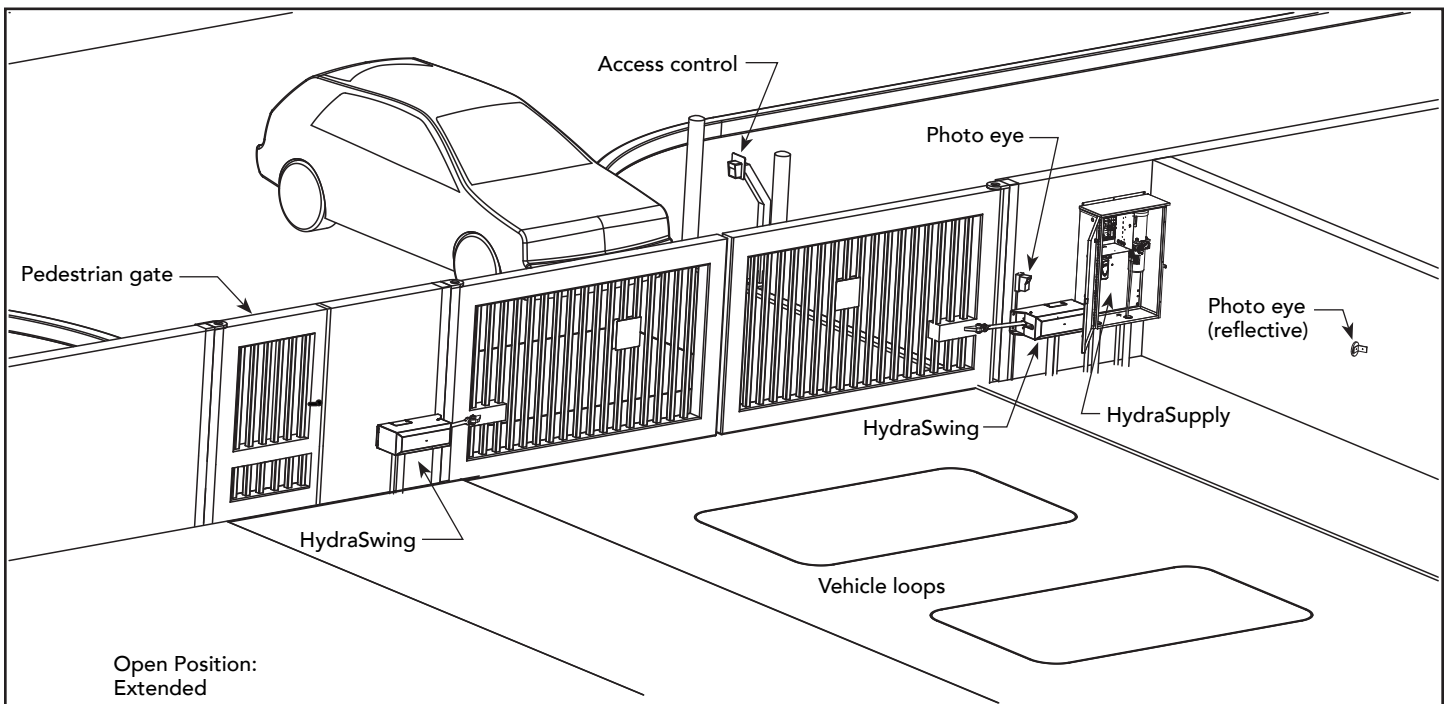

NOTE: To enable fully automatic operation, this gate operator requires a MINIMUM of one external entrapment protection sensor to monitor potential entrapment zones in either the open or close direction of travel. Visit www.hysecurity.com/gatesafety for more information on UL 325 standards and gate safety.

To learn more about external entrapment *protection* devices or to learn how to temporarily supply power to the sensors that are wired to the gate operator, review *External Entrapment Protection Sensors: What the Installer Needs to Do* on page 31 and *Supply Power to the Sensors* on page 34.

PHOTO EYES (NON-CONTACT) INSTALLATION

Plan to integrate photo eyes (photoelectric sensors) in your site plan. Photo eyes are wired to the Controller and require low voltage conduit to the operator and power supply. Review Table 1 under “IMPORTANT SAFETY INFORMATION” on page 19.

If there are no other external entrapment protection sensors (typically an edge sensor), then for slide gates, swing gates or any site that must comply with UL 325 monitored entrapment protection regulations, it is highly recommended that at least two photo eyes are installed to serve and reverse the gate in each direction of travel (Open and Close directions).

Underwriters Laboratories requires that any noncontact sensor used as an external entrapment protection device, must be tested to, and recognized by, the UL 325 Standard.

- There are two common types of photoelectric sensors, thru-beam and retro-reflective, and each has its advantages.
 - A thru-beam sensor is generally more powerful and able to function reliably with dirty optics and in poor weather.
 - A retro-reflective sensor does not require the installation and extra wiring of a separate emitter and receiver as is required in a thru-beam system, but retro-reflective eyes are generally more problematic in poor weather. Avoid using retro-reflective devices across outdoor distances greater than 24 ft (7.3m) because of performance and reliability issues.
 - For pedestrian detection, mount thru-beam type photo eyes approximately 15” to 30” (38 to 76cm) above the ground and as close to the gate as possible. A minimum of one photo eyes is required, but two is recommended, one photo eye to guard the open direction and the other for the close direction of travel, unless gate edges for entrapment protection are installed.
- Three wires to the receiver and two wires to the emitter are all that is required.
 - Depending on how the photo eyes are to be wired, +24VDC or +12VDC, power is provided via spades located just to the right of the COM terminal strip near the left side of the board.
 - The receiver and emitter common wires are connected to the SENSOR COM terminal at the bottom, left of the Smart Touch Controller.
 - The photo eye NO or NC output wires connect to the Smart DC Controller at the Appropriate Sensor Input (1, 2, or 3). The appropriate sensor input must be programmed for Eye Open or Eye Close based on whether it spans the road or the “catch” area of an opening gate.
- If tripped while in motion, the standard function is to stop the gate and automatically restart again if the photo eye is clear within five seconds. An optional setting in the Installer Menu will cause a two second reversal of travel, or, if closing, can be programmed to reverse to full open.

NOTICE: Sensor COM & +24V is the recommended way to connect monitored photo eyes to Smart DC Controller.

NOTICE: If photo eyes are to be used for vehicle detection and logically function the same as a vehicle detector, connect the common wires to the COM terminals on the left side of the board and wire the NO output contact to the appropriate vehicle detector input: EXIT LOOP, IN OBS LOOP, and OUT OBS LOOP.

Compatibility

The UL 325 standard requires that an edge sensor be laboratory tested and “recognized” under UL 325. In order to be compatible with all HySecurity operators, a edge sensor must be rated to function from 24 VDC source power.

A list of tested and approved external entrapment protection sensors (normally closed contacts) that are compatible with HySecurity gate operators can be found online at the following public site: [Gate Safety for HySecurity Gate Operators](#).

Installation

Install photo eyes according to the following steps.

1. Locate the photo eye in line of sight to the receiver or reflector that is mounted to protect zones of potential entrapment. Refer to site layout on page 96.
2. Mount the receivers on the left or right side of the gate operator.
3. Mount the emitters just beyond the travel of the gate.

NOTE: The installation locations are intended for pedestrian detection. If photo eyes are also to be used for vehicular detection, consider (in addition to the low elevation photo eye for cars) installing another photo eye at a height of about 55 inches (140 cm) to detect semi (tractor- trailer) trucks.

Configuration

Configure photo eyes attached to gate operators manufactured in 2016 or beyond according to *Wiring HySecurity Sensors: Smart Touch* on page 111.

NOTE: HySecurity gate operators, manufactured with 2016 (or later) in the serial number, require Normally Closed output sensors. Some manufacturers label an output as N.O. (normally open), when it is actually an N.C. (normally closed) contact. Review Table 1 under “IMPORTANT SAFETY INFORMATION” on page 19.

If your gate operator is manufactured prior to 2016 and your gate operator is set to Build Year 1, consider the following:

NOTE: To check the Build Year for your gate operator, press the Menu button. The gate status scroll reveals the Build Year. “Build Year Pre-2016” means the gate operator is configured for Build Year 1.

1. If the photo eye has an internal switch for setting Light Operate versus Dark Operate, select Light Operate.
2. If the photo eye has a relay output and has both N.O. and N.C. terminals, some experimentation may be required to determine the proper connection because, when its in the Light Operate mode, the output relay is normally energized and releases when the beam is blocked.
3. If the photo eye has a solid-state output, you must choose a sinking-type connection.



Photo Eye Connections: Smart Touch & Smart DC Controllers



All external entrapment protection sensors must be NC sensor outputs and wired to the SENSOR COM terminal for monitoring and powering purposes. The sensor becomes actively powered when the gate operator's motor runs.

Connect the four wires to the receiver and two wires to the emitter according to the following procedure.

A. Supply power to the sensor.

1. Obtain the +24 Volt source power at one of the three spade-terminals on the STC Power Supply Board.
2. Obtain the 24 Volt Common from SENSOR COM on the Controller.

B. Wire connection so the controller recognizes the sensor device.

3. Obtain the COM from the STC Power Supply Board.
4. Connect the N.C. output to SENSOR 1, 2, or 3.
5. Configure the Installer Menu according to your site sensor set up. Refer to *Table 4: Installer Menu Options for SENSOR Inputs* on page 33.

NOTE: Jumper between terminals on Photo Eye sensor so you don't need to pull a fourth wire to the Controller terminal. For examples of wiring diagrams, refer to *page 129*. To test Photo Eye, refer to *Supply Power to the Sensors* on page 34.

Photo Eye Function

A tripped photo eye will prevent the gate from starting in either direction if the gate is stationary. If tripped while in motion, the standard function is to stop the gate motion and then automatically restart again if the photo eye is clear within five seconds. An optional setting in the Installer Menu will cause a two second reversal of travel. Refer to Eye Close Logic and Eye Open Logic (EC and EO) in the *Table 6: Installer Menu* on page 46 for more information.

Alignment:

Most photo eyes require careful optical alignment in order to aim the emitter beam to the center of the receiver or reflector. In order to avoid false triggering, it is important to carefully align the system, especially with retroreflective photo eyes. The best way to assure true centering of the beam is with some trial testing where the emitter is shifted to move the beam left and right and up and down until the range of the invisible cone of the infrared beam is known. Photo eyes usually provide alignment aid LED's for this setup, but they can be hard to see. HySecurity has provided a unique feature that turns power on to the photo eyes and causes the buzzer to chirp when the photo eyes enter and exit alignment. See "Table 9. Smart DC Controller - User Menu Functions" on page 53 to enable this feature. Set the menu item PE - PHOTO EYE ALIGN from a 0 to a 1. The buzzer chirps once when the emitter and photo eye receiver are not aligned. When the emitter and receiver are aligned, the buzzer chirps twice. If they go out of alignment again, the buzzer will chirp once. This "alignment mode" will automatically reset to 0 the next time the Close Limit Switch is triggered or the RESET key is pressed.

RETRO-REFLECTIVE PHOTO EYE SYSTEMS

Correct installation and alignment of a retro-reflective photo eye and its reflector is important for trouble free performance. Any system operating at a range greater than 16 feet is more prone to false triggering due to dirty optics, condensation or poor weather. If care is taken in the initial mounting and alignment of the 3-inch reflector, the chance of problems is greatly reduced. Use only through beam photo eyes for a distances greater than 24 feet because the function of a retro-reflective photo eye will be too unreliable.

Taking steps to protect the photo eye and the reflector from being exposed to fog and being absolutely certain the photo eye is perfectly aligned will greatly reduce any false triggering of the system. The ideal mounting of a retro-reflective photo eye is inside an enclosure.

The ideal reflector mounting suspends it inside a 12-inch long piece of 3-inch PVC conduit. Cut the opening of the PVC conduit at a 45-degree angle to act as a drip shield. Hold the reflector against the backside of the PVC conduit by attaching a 3-inch male connector. Do not cement the connector. This would prevent the reflector from being reached for future cleaning. To create a mounting base, attach a 3-inch aluminum flange (electric meter hub) to the connector. This whole package can be mounted to any flat surface. Locate the reflector in the center of the invisible beam of infrared light to achieve the most sensitive alignment.

Locate the reflector in the center of the invisible beam of infrared light to achieve the most sensitive alignment. The beam center is determined by the following test: while holding the reflector in your hand, slowly raise it until the beam is no longer returned and the photo eye trips. Mark this maximum height. Now lower your hand and determine the lower limit of the infrared beam by watching for the trip point. Mark this position as well. Repeat the same procedure for left and right at the center elevation of the beam, as determined by the previous test. Once the four limits have been determined, either mount the reflector in the center of the area outlined or realign the eye for the position of the reflector. If photo eye is realigned, be sure to perform centering test again to verify that the reflector is truly in the center.

USING PHOTO EYE SENSORS INSTEAD OF VEHICLE LOOPS

Some site conditions (for example, dirt or gravel roads) may warrant use of photo eye sensors for vehicle detection. In this type of application, the photo eye pair is connected to vehicle loop terminals on the Controller.

NOTE: A pair of photo eye sensors, used in place of vehicle loops and wired to vehicle loop terminals on the Controller, does not satisfy UL 325 Standard of Safety for "monitored" external entrapment protection. To understand external entrapment protection and how HySecurity equipment monitors sensors, refer to the section titled *Entrapment Protection* on page 29.

Smart Touch Controller

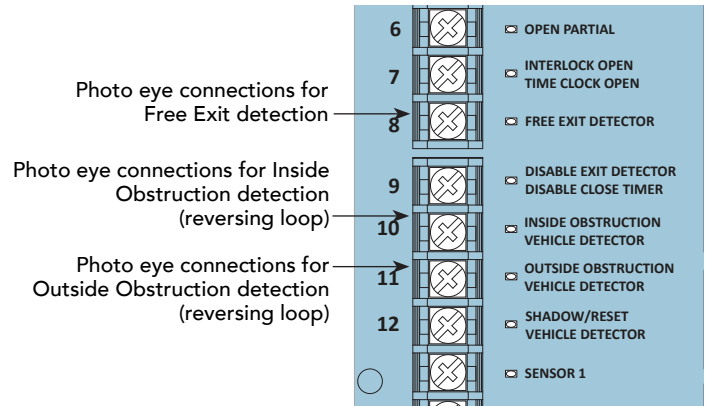

Photo Eye sensor terminal connections when PE sensors used in place of vehicle loops

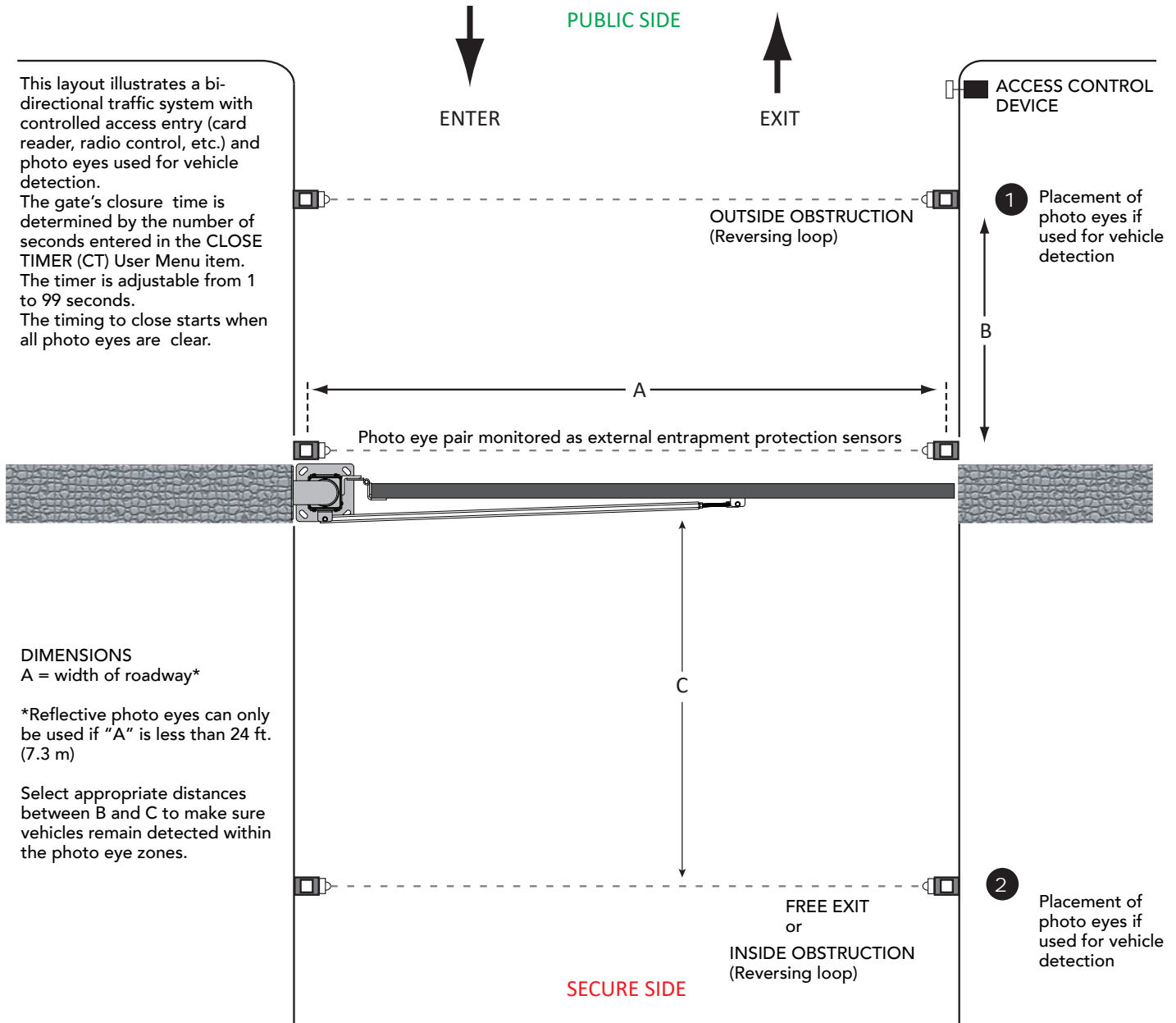
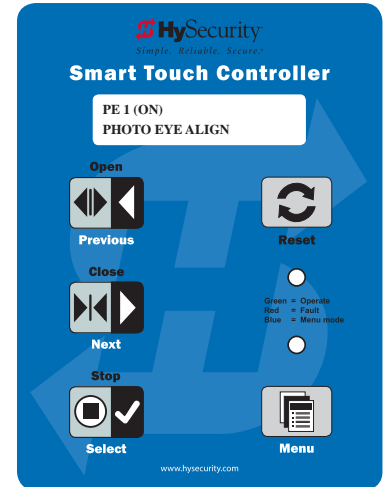

PHOTO EYE ALIGNMENT FEATURE

Most photo eyes require careful optical alignment in order to aim the emitter beam to the center of the receiver or reflector. In order to avoid false triggering, it is important to carefully align the system.

Align the photo eyes using this feature by taking the following steps:

1. Access the User Menu and select PE.
To access the User Menu, press the Menu button twice. For a refresher on using the Menu Mode navigational buttons, refer to the chart below.
2. Press NEXT and continue to press NEXT until PE 0 (OFF) appears.
3. Press SELECT.
PE characters begin blinking.
4. To turn ON photo eye alignment and temporarily power the sensors, press NEXT so PE 1 (ON) appears.
5. Press SELECT.
PE stops blinking.
6. Move the photo eyes (up/down, side to side) to align the emitter beam.



Audible Chirp	Beam Aligned ??
One	No
Two	Yes

7. When the buzzer chirps twice, indicating the photo eyes are aligned, set the next photo eye (if the site has one) and continue the process until all photo eyes are aligned.
8. Press MENU to exit Menu Mode and return to Run Mode.
9. Move the gate with an open or close command. When a limit is triggered, the User Menu item PE resets to zero (OFF).

NOTE: To cover the potential entrapment areas, mount photo eyes preferably within 5 inches (13 cm) of the gate face. Refer to *Installation* on page 98. To learn how to temporarily power external entrapment protection sensors using the PE User Menu item, refer to *Supply Power to the Sensors* on page 34.

Smart Touch Controller: Menu Mode Navigation Buttons

To access Menu mode	To change menu item appearing in the display	To navigate through the menu item selections	To choose what item appears on the display	To navigate between menu items
Press the Menu button twice.	Press Select. Two left characters blink.	Press Next or Previous. Continue pressing Next to view all selections.	Press Select. Blinking characters become static.	Press Next or Previous. Advance - press Next Previous - press Previous

Installing Gate Edge Sensors

A monitored connection tests for the presence and correct operation of the gate edge sensors (and other monitored sensors) prior to gate activation. The monitored connection prevents gate operation if a sensor is missing or any fault is present.

Sensors, such as gate edges and photoelectric beams, must be installed to protect against entrapment. These external entrapment protection sensors are required for the gate installation to be in compliance with the 2018, UL 325 Standard of Safety (7th Edition).

NOTICE: UL 325 Standard of Safety provides the MINIMUM safety standards. Site, gate hardware usage, and other conditions may dictate the use of additional safety designs/components. It is up to the gate system designer and installer to assess appropriate safety design and components above and beyond minimum UL 325 and ASTM F2200 Standard of Safety. Always check your local area codes and comply with all regulations.

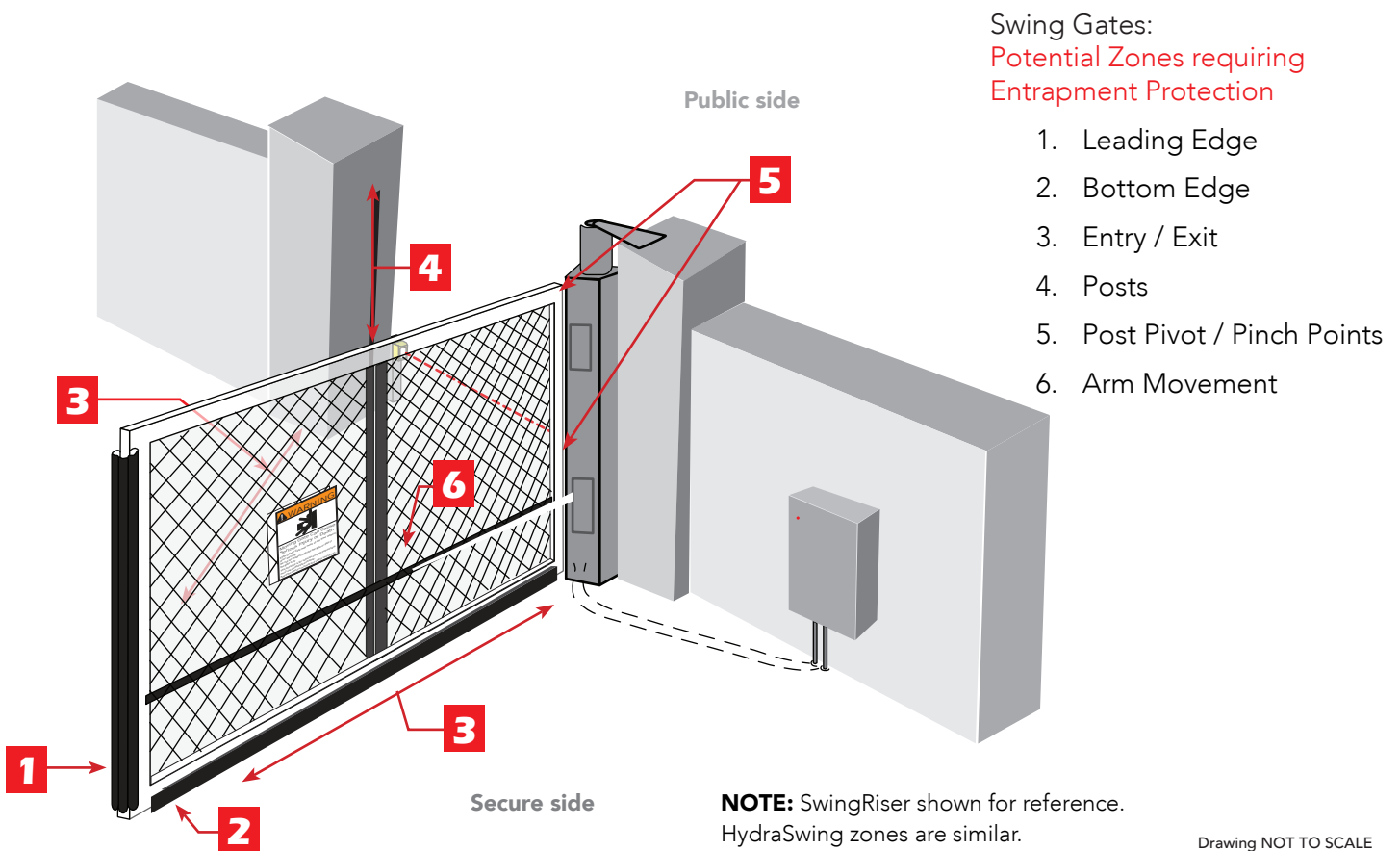

Assess your gate site for the most appropriate placement of edge sensors. Plan to integrate contact (gate edge) and non-contact (photo eyes) sensors in your site plan. Sensors are wired to the Controller and require low voltage conduit to the operator and power supply. Review Table 1 under "IMPORTANT SAFETY INFORMATION" on page 19.

To enable fully automatic operation, this gate operator requires a MINIMUM of one external entrapment protection sensor to monitor potential entrapment zones in either the open or close direction of travel. Visit www.hysecurity.com/gatesafety for more information on UL 325 standards and gate safety.

Compatibility

The UL 325 Standard of Safety requires that a photoelectric sensor be laboratory tested and “recognized” under UL 325. In order to be compatible with all HySecurity gate operators, a photo eye must be rated to function from 24 VDC source power.

A list of tested and approved external entrapment protection sensors (normally closed contacts) that are compatible with HySecurity gate operators can be found online at the following public site: [Gate Safety for HySecurity Gate Operators](#).

Installation

NOTE: Follow the manufacturer’s installation and assembly instructions to properly mount the sensor. Wiring diagrams for several sensor devices are found in *Wiring HySecurity Sensors: Smart Touch on page 111*.

HySecurity gates monitor normally closed (NC) sensors. Wire the NC sensors to SENSOR input terminals (SENSOR 1, SENSOR 2, or SENSOR 3) on the Smart Touch Controller and set the Installer Menu item S1, S2, or S3 to the appropriate setting for the area being monitored.

When using wired edge sensors, the wired edge must be connected to an interface module with an NC output. ASO® has UL 325 - 2018 compliant edge sensors. These edge sensors have a 10k Ω resistor that connects to an interface module. The interface module provides the NC output for monitoring purposes. Refer to *Wiring HySecurity Sensors: Smart Touch on page 111*.

For wireless edge sensors, no interface module is required. Wireless edge sensors need the wireless gate links which include a transmitter and receiver. HySecurity has created kits for all-inclusive shipment.

NOTE: The installation locations are intended for pedestrian detection and safety. The potential zones requiring entrapment protection are areas that need to be protected for pedestrian safety.

Edge Sensor Installation Tips

- If edge sensors are used sliding gates, one or more contact sensors (edge sensors) must be located at the leading edge, trailing edge and post-mounted both inside and outside of the sliding gate.
 - Three-sided detectors are ideal for slide gates.
 - If the clearance of the gate is 4” (10cm) or more above the road, then an edge sensor must be mounted on the bottom edge.
 - If gate is sliding open to a wall with less than 16” (41cm) of clearance, mount an edge sensor to wall that aligns with gate in open position.
 - Always route leads from edge sensors to gate operator so that they are protected from physical damage.
 - Underwriters Laboratories requires that any contact sensor used as an external entrapment protection device, must be laboratory tested to, and recognized to the UL 325 Standard.
- To enable monitoring of edge sensors, there must be a terminating resistor in the embedded in the edge. This resistor is typically 8.2K or 10K and always has a small current draw to confirm that it is installed.
- HySecurity gate operators must see a NC contact for monitoring purposes, therefore any edge sensor with a terminating resistor will need an interfacing device to convert the resistor output into a NC contact.
 - Types of devices that will convert the resistor output to NC output include the Hy2NC and the WEL-200.
 - Hy2NC enables the Edge Sensor to be hard wired to the board.
 - The WEL-200 is a wireless transmitter/receiver kit that communicates the state of the Edge Sensor wirelessly from the gate mounted transmitter to the operator mounted receiver.

- Hard-wired edge sensor adaptors (like Hy2NC) have inputs for up to two resistor terminated edges and up to two NC contact outputs.
 - HySecurity suggests the use of hard-wired edge sensor adaptors with an edge mounted to lead fence post to protect draw-in entrapment zone when the gate is running.
- Wireless transmitters are always monitoring for presence of resistor terminated edge(s) connected to it. Status of edge is then continuously communicated back to receiver which determines when to switch NC contact to NO and tell board edge is tripped or missing.
 - Receiver can only give a NC (edge not tripped) signal or a NO (edge tripped or missing) signal to control board.
 - If edge is tripped, missing, or resistor value is too low, transmitter will communicate this information to receiver which will indicate this to control board as a tripped edge (NC contact opens).
 - Additionally, if communication between transmitter and receiver is ever lost or corrupted, due to too much RF "noise" in area, then the receiver will indicate to control board that the edge is tripped, even if edge is present and functioning normally with transmitter.
- When selecting a wireless edge as one of the external entrapment sensors, be aware of the environment around it and know that RF interference from outside sources can drastically diminish range and performance of wireless device.
 - Airports, police stations, fire departments, hospitals, and other sites with a lot of radio traffic have shown to have a lot of RF noise in frequencies that most transmitter/receiver kits function.
 - Install transmitter in a way that it is in direct line of site with receiver's antenna throughout gate motion.
 - Limit distance between transmitter(s) and receiver(s) to what is specified by manufacturer, and be aware that range may be greatly diminished when operating in a noisy RF environment.

Gate Edge Function

If the gate is stationary, a tripped gate edge sensor will prevent the gate from starting in either direction. If tripped while in motion, the standard function is to stop the gate movement and, if tripped while closing, automatically re-open fully. An optional setting in the Installer Menu will cause a 2 second reversal if triggered while closing. Refer to *Table 6: Installer Menu* on page 46 for more information.



Example: Wired gate edges used with 10K Ω (8.2K Ω) resistor



Example: Wireless gate link (transmitter & receiver) used with wireless gate edges

Troubleshooting

The Smart Touch Controller reports system malfunctions using three simultaneously occurring methods:

- Codes presented on its display (alert, fault or error)
- Activation of a buzzer which emits a series of chirps at defined intervals
- Stop gate travel (and/or reverse direction of travel)

Refer to *Table 8: Troubleshooting Codes* on page 107 for details concerning identification and description of Alerts, Faults and Errors.

Overriding a tripped sensor or fault condition on a HySecurity gate operator with monitored entrapment sensors requires a 2-step process:

- Press Open or Close momentarily. Audible beeps in quick succession indicate tripped sensors or fault conditions.
- Within 5 seconds of hearing the beeps, apply constant hold pressure to override the tripped sensor or fault. The gate operator runs while pressure is maintained to actuating device (examples include, Push button Open, Push button Close, Open Partial or Keypad Open/Close), or a limit is reached, or another sensor trips.



NOTE: A qualified technician may troubleshoot the operator with the aid of the information and procedures that follow. If it is necessary to call a distributor for assistance, be sure to have the model and serial numbers available. Other helpful information is the job name, approximate installation date, and service records of any recently-performed maintenance work.

TIP: On AC-powered gate operators, the active status of each input on the Smart Touch Controller is indicated by its associated lit LED. However, an exception exists in the case of external entrapment protection sensors. The LEDs next to the sensor connections will be lit when no power is being applied. For more information, refer to *Supply Power to the Sensors* on page 34.

SYSTEM DIAGNOSTIC MESSAGES

Code	Priority	How to clear
ALERT	Low	Enter new command such as Open or Close.
FAULT	Medium	Press the Stop or Reset button
ERROR	High Serious issue that may require technical service.	Errors can only be cleared by pushing the Reset button or cycling power.

NOTE: The green LED near the coin-sized battery on the Smart Touch Controller is the “heartbeat” of the processor. This LED flashes continuously and at a constant rate when the system is operating normally. When a fault, error, or alert occurs, it turns red.

The Smart Touch Controller maintains self-diagnostics. Specific codes appear on the display and the Audio Alert buzzer emits distinctive chirping sounds. Any Alert, Fault, or Error is logged into memory and stamped with the date and time. These diagnostic messages can be retrieved for analysis purposes via optional S.T.A.R.T. software and a PC laptop.

NOTE: S.T.A.R.T. configuration and diagnostic software is available at no charge from www.hysecurity.com.

Table 8: Troubleshooting Codes

Type	Alert/Fault/Error Display	Buzzer Chirp Sequence	Possible Cause &	Solutions
ALERT	Entrapment Mode Alert	2 chirps per second every 2s while control input is active	Occurs when IES is tripped when gate is already in Safe Mode. Operator will not function until it is reset, which can occur by: <ul style="list-style-type: none"> • An Open or Stop command from a push-button control • Pressing black button on operator side • Pressing RESET button below display With any one of these inputs, operator will return to Safe Mode. Gate binding or wind can cause a false alert.	<ol style="list-style-type: none"> 1. Remove obstruction. 2. Adjust IES sensitivity. 3. Correct gate hardware.
ALERT	Safe Mode Alert	2 chirps once when in Safe Mode	Occurs when either edge sensor or Inherent Entrapment Sensor (IES) has been tripped. In Safe Mode, automatic close timer is disabled, but any command will reset and/or start gate in motion. Safe Mode clears when full travel is reached or RESET button is pressed. Gate binding, wind, a faulty edge sensor, or worn motor brushes can cause a false alert.	<ol style="list-style-type: none"> 1. Remove obstruction. 2. Adjust IES sensitivity. 3. Correct gate hardware. 4. Correct faulty edge sensor. 5. Check for worn motor brushes and replace, if necessary.
ALERT	Low 24VDC DC BUSS < 21V	No chirps; LCD flashes for 1s every 5s	Only occurs in DC powered operators. Occurs when battery voltage has dropped to less than 22V. At this level, batteries are 80% depleted. Normal function until 21V.	<ol style="list-style-type: none"> 1. No AC Power. See above item. 2. Wiring / Connector problem - check all connections. Clean or repair as required. 3. Check battery condition. 4. Smart DC Controller or Smart Touch Controller charger failure - check charger voltage and replace Smart DC Controller. 5. Transformer failure - replace transformer.
ALERT	Critical Low Power	No chirps: LCD steady and controls disabled	DC power is below 14V – no control functions will be allowed at all.	<ol style="list-style-type: none"> 1. No AC Power. See above item. 2. Wiring / Connector problem - check all connections. Clean or repair as required. 3. Check battery condition.

Type	Alert/Fault/Error Display	Buzzer Chirp Sequence	Possible Cause &	Solutions
ALERT	Dead Battery DC BUSS < 21V	3 chirps upon any operating command entry	Occurs when battery voltage has dropped to less than 21V. At this level, batteries are 90% depleted. Gate will automatically open or close depending upon setting chosen. Refer to AP - AC LOSS "User Menu" on page XX. No additional automatic function is possible, but limited push button control is available to 18V.	<ol style="list-style-type: none"> 1. No AC Power. See above item. 2. Wiring / Connector problem - check all connections. Clean or repair as required. 3. Check battery condition. 4. Smart DC Controller or Smart Touch Controller charger failure - check charger voltage and replace Smart DC Controller. 5. Transformer failure - replace transformer.
ALERT	No AC POWER	Chirps once whenever the gate reaches the close limit	AC power is shut off at the source (breaker) or is not connected. The operator's AC power switch is turned off or the main circuit breaker has tripped.	<ol style="list-style-type: none"> 1. Turn AC power switch on or connect power to operator. 2. Reset operator circuit breaker or connect power to AC switch. 3. Reset circuit breaker at electrical panel. 4. Have a licensed electrician check wiring.
ALERT	!ACTION BLOCKED PHOTO EYE CLOSE PEC	5 chirps indicating that the command cannot be initiated	<p>Photo eye is not recognized as active.</p> <ul style="list-style-type: none"> • Clear photo eye path • Realign photo eye. Refer to "Photo Eye Alignment Feature" on page 102. • Replace photo eye battery • Check N.C. wiring (verify wires are not disconnected or shorted) • Review wiring diagrams. Especially path to SENSOR COM • Make sure SENSOR settings S1, S2, and S3 are correctly assigned. Refer to Refer to <i>External Entrapment Protection Sensors: What the Installer Needs to Do</i> on page 31. 	

Type	Alert/Fault/Error Display	Buzzer Chirp Sequence	Possible Cause &	Solutions
ALERT	!ACTION BLOCKED PHOTO EYE OPEN PEO	5 chirps indicating that the command cannot be initiated	Photo eye is not recognized as active. <ul style="list-style-type: none"> • Clear photo eye path • Realign photo eye. Refer to <i>Photo Eye Alignment Feature</i> on page 88. • Replace photo eye battery • Check N.C. wiring (verify wires are not disconnected or shorted) • Review wiring diagrams. Especially path to SENSOR COM • Make sure SENSOR settings S1, S2, and S3 are correctly assigned. Refer to <i>External Entrapment Protection Sensors: What the Installer Needs to Do</i> on page 31. 	
ALERT	!ACTION BLOCKED GATE EDGE (Open or Close) GEO	5 chirps indicating that the command cannot be initiated	Operator received command to run open, but movement is prevented. Gate edge blocked or disconnected and causes operator to enter SAFE mode. Gate edge is not recognized as active. <ul style="list-style-type: none"> • Replace sensor batteries • If using Miller Monitored Edge Link, be aware. Issues with radio interference cause false trips. Placing the antenna high and reducing environmental "noise" is critical to proper wireless transmission. Avoid placing the receiver sets within 100 feet of each other as crosstalk may occur. Use receivers & transmitters Version 1.02 or later. • Verify wired edges are using a gate edge converter-type module. Miller Edges must have a wire with blue tape. The blue tape indicates that a resistor is built in. • Check N.C. wiring (verify wires are not disconnected or shorted) • Review wiring diagrams. Especially path to SENSOR COM • Make sure SENSOR settings S1, S2, and S3 are correctly assigned. Refer to <i>External Entrapment Protection Sensors: What the Installer Needs to Do</i> on page 31. 	
ALERT	ALERT 1 Forced Open	2 pulses per second for 30s	Gate has been forced open from a full close limit and is being prevented from re-closing.	Will self-clear after an open or close input.
ALERT	ALERT 2 Drift Closed	2 pulses per second for 10 seconds	Gate has been forced open from a full close limit and is being prevented from re-closing.	Will self-clear after an open or close input.
ALERT	ALERT 3 EXCESS DRIFT	Gate drift in transit - Advisory only. The alert appears and is being prevented from re-opening.	Alert appears if gate drifts three times in a five minute period.	Check track to make sure it is level.

Type	Alert/Fault/Error Display	Buzzer Chirp Sequence	Possible Cause &	Solutions
ALERT	ALERT 4 THERMAL Overload	2 chirps per second every 15 seconds	Motor drive heat sink exceeds 195°F. Alert will temporarily disable operator, but will automatically reset itself when it cools down. May also occur if the heatsink temperature is 70°F. higher than ambient temperature.	Check gate hardware, weight/length of gate. Alert automatically clears when temperature drops below threshold.
ALERT	ALERT 5 Both Lim ACTIVE	2 chirps per second every 15 seconds	The STC is seeing both limits tripped at the same time. Check for a stuck limit switch or debris caught in limit switch area and repair any wiring issues. On electromechanical gate operators and StrongArmCrash, reset the limits through the Installer Menu item, LL Learn Limits.	
ALERT	ALERT 6 Lim not released	2 chirps per second every 15 seconds	Is the pump developing pressure? Are the brake valves set properly? Is there hardware holding the gate? <ul style="list-style-type: none"> • Check fluid levels and brake valve settings. 	
ALERT	ALERT 7 Freq SHIFT FAULT	2 chirps per second every 15 seconds	Hy5x detector has detected a frequency change outside the normal range. Likely causes are poor integrity of loops or metallic objects within range. This message will also indicate which detector alert applies to: Exit Loop (ELD), Inside Obstruction Loop (IOLD), Outside Obstruction Loop (OOLD), or Center Loop (CLD) - (User Relay 22).	Loop lead in wires and road way should be checked for problems or replaced.
ALERT	ALERT 8 LOOP SHORTED	2 chirps per second every 15 seconds	Hy5x detector has detected a short circuit in the loop. Temporarily switch detector to be sure the loop is at fault and then repair it. Caused by inadequate insulation of loop wires.	Loop lead in wires and road way should be checked for problems or replaced.
ALERT	ALERT 9 LOOP OPEN	2 chirps per second every 15 seconds	Hy5x detector has sensed that the loop has become an open circuit. Check all connections and/or use an ohmmeter to find out where the break is. Caused by broken loop wire or wire has come unplugged from detector.	Loop and lead in wires should be checked for problems or replaced.
ALERT	ALERT 10 I2C BUS ERROR	2 chirps per second every 15 seconds	Communication issue between the Hy5x and the Smart Touch Controller; reset and try again. Replace the Hy5x if the problem continues. Caused by removal of HY-5B or lack of integrity of socket connection. This message will also indicate which detector alert applies to: Exit Loop (ELD), Inside Obstruction Loop (IOLD), Outside Obstruction Loop (OOLD), or Center Loop (CLD) - (User Relay 22).	Remove and re-install the HY-5B and press RESET. Replace HY-5B, if necessary.

Type	Alert/Fault/Error Display	Buzzer Chirp Sequence	Possible Cause &	Solutions
ALERT	ALERT 11 DETECTOR FAULT	2 chirps per second every 15 seconds	Unknown fault; perform the megaohm test and fix the loop if necessary. Caused by a fault within HY-5B. This message will also indicate which detector alert applies to: Exit Loop (ELD), Inside Obstruction Loop (IOLD), Outside Obstruction Loop (OOLD), or Center Loop (CLD) - (User Relay 22).	Remove and re-install the HY-5B and press RESET. Replace HY-5B, if necessary.
ALERT	ALERT 12 ON TOO LONG	2 chirps per second every 15 seconds	Caused when Smart DC Controller sees an active loop for more than 5 minutes. "Active" loop can be actual or false. This message will also indicate which detector alert applies to: Exit Loop (ELD), Inside Obstruction Loop (IOLD), Outside Obstruction Loop (OOLD), or Center Loop (CLD) - (User Relay 22).	Check traffic patterns at site. Loop and lead in wires should be checked for problems or replaced.
ALERT	ALERT 13 STIFF GATE	2 chirps per second every 15 seconds	The STC detects a gate that, over time, is requiring more power to move it. Caused by degrading gate hardware or debris in track. This alert appears in history log. It does not have any effect with regard to opening or closing gate.	Check and correct gate hardware as required.
ALERT	ALERT 14 STUCK GATE	2 chirps per second every 15 seconds	The STC detects that it cannot move the gate because of possible broken gate hardware or ice/snow buildup.	Check and correct gate hardware as required.
ALERT	ALERT 15 NO TARGET		Target magnet on the chain is missing or has not been detected. Target magnet fell off or target sensor wires are damaged.	<ol style="list-style-type: none"> 1. Make sure target is properly fastened to chain. 2. Check target sensor to make sure it is reading magnet. Change sensor if it or its wires are damaged.
ALERT	ALERT 16 COM BUS ERROR		Smart Touch Controller has detected an internal communications error. <ul style="list-style-type: none"> • Excessive electrical noise. • Lack of earth grounding. • Internal problem on Smart Touch Controller. 	<ol style="list-style-type: none"> 1. Determine and remedy source of electrical noise. 2. Install a ground rod. 3. Replace Smart Touch Controller.
ALERT	ALERT 17 BAD COIN BATTERY	2 chirps per second every 15 seconds	Small battery on Smart Touch Controller is loose or needs replacing. Use a CR2032 coin battery.	<ol style="list-style-type: none"> 1. Verify that battery is properly seated. 2. Replace coin battery. 3. Restore power. 4. Press RESET button.
ALERT	ALERT 18 CHANGE BATTERY	1 chirp a minute	Batteries are not taking a charge. The STC has detected that the 24VDC UPS batteries need to be replaced.	The buzzer will chirp every minute until the UPS batteries are replaced.

Type	Alert/Fault/Error Display	Buzzer Chirp Sequence	Possible Cause &	Solutions
ALERT	ALERT 19 FALSE SLOWDOWN	2 chirps per second every 15 seconds	Appears only on gate operators with VFD. Slowdown switch tripped and released (less than 1 second) in middle of run. Check for loose wires, limits and misaligned rails or limit ramps.	
ALERT	ALERT 20 EXT LOCK FAILED	2 chirps per second every 15 seconds	An interlock contact is closed, indicating that the gate latch (lock) is engaged, preventing the operator from starting. Check the interlock terminal and wiring.	
ALERT	ALERT 21 DRIVE TRIP	2 chirps per second every 15 seconds	Gate travel will not occur until the alert is cleared. Any open or close command resets the alert and starts the gate moving, unless the VFD is experiencing a fatal error. If you cannot clear the error alert by pressing the open or close button, contact HySecurity.	
ALERT	ALERT 22 INTLOCK FAILURE	2 chirps per second every 3 seconds	Appears when the RS-485 communication connection is lost for more than 5s between interlocked (dual gate) or sequenced gate operators.	<ol style="list-style-type: none"> 1. Check cable connections and wiring. Make sure both operators are working properly and have compatible software versions. The alert auto clears when communication between the two operators is restored. 2. If the operator on site is a singular gate and the display code ALERT 22 appears, access the Installer Menu. Verify the Installer Menu items: DG (Dual gate) and SG (Sequential gate) are both set to zero.
ALERT	ALERT 24 EXT RELAY FAULT	2 chirps per second every 15 seconds	<p>The Hy8Relay (extended relay module) is not being recognized. Alert noted in diagnostic log. Check the wiring:</p> <ul style="list-style-type: none"> • Make sure the slide switch on the side of the extended relay module is set at "Normal." • (Y) Data + is connected to "A" DUAL GATE. • (G) DATA - is connected to "B" DUAL GATE. • Connector cable (4-pin) attaches to RS-485. <p>If Hy8Relay module is not connected, access the Installer Menu. Check that the extended user relays are set to zero. STC = R4 to RB (7-segment display) SDC = R3 to R9 (32 character display) STC = R4 to R11 (32 character display)</p>	
ALERT	ALERT 25	N/A	HyNet Only. The HyNet coin battery is dying. Turn off AC power to the HyNet and replace the existing coin battery with a CR1220 coin battery. Turn On power to the HyNet. The ALERT should reset and disappear from the display.	

Type	Alert/Fault/Error Display	Buzzer Chirp Sequence	Possible Cause &	Solutions
ALERT	ALERT 26	2 chirps per second every 15 seconds	<p>Only appears in HydraSupply XL. When valve closures or IES trips do not detect limit switch triggers or, if the appropriate limit switch is not reached within 10s of receiving an operate command and the pressure switch is open, then Alert 26 – Lim Not Reached will be declared.</p> <p>If the barrier moves by pressing an operate command, the display resets and the ALERT 26 timer rearms.</p>	
ALERT	ALERT 27	2 chirps per second every 15 seconds	<p>Only appears in HydraSupply XL. The fluid level in the accumulator is low. An EFO may not trigger properly.</p> <p>Have service personnel check the HydraSupply XL. Cycle the barrier and watch the pressure gauge. If the pressure is low, the blocking plate does not rise or the motor times out, check hoses for leaks. If necessary, recharge the accumulator.</p> <p>While ALERT 27 appears on the display, a renewed close command will attempt to run the barrier, but the alert will not clear unless the close limit is reached or a reset is pressed.</p>	
ELD OOLD IOLD SLD RLD	<ul style="list-style-type: none"> • “Vehicle Loop Detectors” 		<p>Appears in sequence with another display code which pertains to the loop issue. Refer to the other display code for more information. ELD = Exit Loop Detector OOLD = Outside Obstruction Loop Detector IOLD = Inside Obstruction Loop Detector SLD = Shadow Loop Detector RLD = Reset Loop Detector</p>	
FAULT	<ul style="list-style-type: none"> • FAULT 1 • MOTOR RUN TIME 	<ul style="list-style-type: none"> • 1 chirp once every • 15 seconds 	<p>The STC has detected the motor is on longer than the maximum run time selected.</p> <p>Check and replace drive belt on applicable gate operators.</p> <p>Increase Max Run Timer in the Installer Menu.</p>	

Type	Alert/Fault/Error Display	Buzzer Chirp Sequence	Possible Cause &	Solutions
FAULT	FAULT 2 PHOTO EYE	2 chirps per second once per minute	<p>"Monitored" means the Controller must see the photo eye N.C. contact change from open to close after receiving the command to run, but before starting the motor. FAULT 2 indicates the controller did not see this sequence when the gate received a run command.</p> <p>Check the wiring. Refer to the wiring diagram associated with the attached sensor. See <i>Wiring HySecurity Sensors: Smart Touch</i> on page 111.</p>	Be sure the eye "common" wire is wired properly to the SENSOR COM terminal.
FAULT	FAULT 3 LOW VOLTAGE SAG	2 chirps per second once per minute	<p>The 24V control voltage is monitored in lieu of line voltage. Low incoming line voltage will cause low control voltage. Verify that the control transformer is connected properly, (white – not used, red for 208V, orange for 230V and blue for 460V). Check the line voltage as the motor starts with a meter that has min/max hold capability. If the line voltage drops more than 10% below nominal (187 on 208VAC, 207 on 230VAC, or 416 on 460VAC) the voltage is dropping too low and must be corrected. This condition is often caused by loose connections or the wire size being too small. If the wire is too small, it must be replaced.</p>	
FAULT	FAULT 4 GATE NO LOAD		<p>Smart Touch Controller has detected there is no load on operator. Gate is non-operational while this fault is triggered.</p> <ul style="list-style-type: none"> • Motor wires disconnected. • DC switch off. 	<ol style="list-style-type: none"> 1. Check DC motor wires. 2. Turn DC power switch on. 3. Press RESET to clear fault.
FAULT	FAULT 5 LIMIT FAILED	2 chirps per second once per minute	<p>50VF series only. Not applicable for StrongArm M30/M50. Slow down to stop limit took too long. Possible bad limit switch.</p> <ul style="list-style-type: none"> • Verify limits and placement of slow down limit ramps. • With drive wheels clamped, test Open (GATE OPENING appears on display). Test Close (GATE CLOSING appears on display). 	
FAULT	FAULT 14 STUCK GATE	2 chirps per second once per minute	<p>The STC has tried 3 times to overcome a stuck gate. The gate is non-operational while this fault is triggered. Caused by broken gate hardware or ice/snow buildup.</p>	<ol style="list-style-type: none"> 1. Check and correct gate hardware as required. 2. Press RESET to clear fault.

Type	Alert/Fault/Error Display	Buzzer Chirp Sequence	Possible Cause &	Solutions
ERROR	ERROR 1 Direction Error	3 chirps per second once per minute	Smart DC Controller detects operator ran in wrong direction. Close Limit tripped after running Open or Open Limit tripped after running Closed. Assess cables and wire connections. <ul style="list-style-type: none"> • Motor wiring. • Make sure wires are connected to the proper terminals. Make sure gate handing (if applicable) is appropriate. • Swap connections of hydraulic hoses, if necessary. 	<ol style="list-style-type: none"> 1. Check and correct gate hardware as required. 2. Press RESET to clear fault.
ERROR	ERROR 2 IES Disconnect	3 chirps per second once per minute	<ul style="list-style-type: none"> • The IES sensor could be bad, check to see that the NC contact is intact. • Check that you have the most current sensor; visit our website and view the technical bulletins in the Tech Support area. The sensor wire could be loose; you may want to tighten the female connectors with some pliers. • Verify the version of the software by pressing the Reset button. The software version appears on the display. Make a note of it. The software version should be h4.50 or h5.50 (or later). • If necessary, update the software using a PC laptop and S.T.A.R.T. Register and login in at www.hysecurity.com 	
ERROR	ERROR 3 HY5 COMM ERROR	3 chirps per second once per minute	Smart DC Controller detects communication error with a HY-5B vehicle detector. Caused by HY-5B removal or lack socket connection integrity. Message indicates which detector alert applies to: Exit Loop (ELD), Inside Obstruction Loop (IOLD), Outside Obstruction Loop (OOLD), or Center Loop (CLD).	Remove detectors, reset the controller, and re-install detectors one at a time until faulty detector or loop is found.

Type	Alert/Fault/Error Display	Buzzer Chirp Sequence	Possible Cause &	Solutions
ERROR	ERROR 4 PRIMARY / SECONDARY COM	3 chirps per second once per minute	Smart DC Controller has detected a communication error between primary and secondary in a dual gate installation. <ul style="list-style-type: none"> • Primary/Secondary communication cable has not been installed correctly. See Primary and Secondary Wiring Connections. • Primary/Secondary not configured properly through Installer Menu. • Operator not properly grounded. Operator not properly earth grounded. • Primary/Secondary communication cable installed in same conduit as high-voltage AC power. • One operator does not have power applied to it. • One operator may have a different software version. 	<ol style="list-style-type: none"> 1. Correct communication cable. 2. Verify each operator is configured properly via Installer Menu. Set one operator as Primary, one as Secondary. 3. Install ground rod per NEC/NFPA standard. 4. Install separate communication cables conduit. 5. Ensure AC power is present at both operators and all power switches are ON. 6. Check software version currently loaded in operator by pressing RESET. Make sure both operators are running same software version.
ERROR	ERROR 5 NO DISPLAY		Display provides no indication of this error, but it can appear in START log and means that Smart DC Controller has detected a serious internal error. Internal software/hardware error. Report any instance of this error to HySecurity Technical Support.	<ol style="list-style-type: none"> 1. Turn both switches off to reset software. 2. Update to latest software version using START. 3. Replace Smart Touch Controller.
ERROR	ERROR 6 STC-VFD COMM ERR	3 chirps per second once per minute	Internal error between the STC board and the VFD. Check cable connections and wiring. Make sure both units are working properly.	
ERROR	ERROR 7 MENU CHECKSUM ERR7	3 chirps per second once per minute	Software issue exists that may require factory reset. Corrupt software or data.	Call HySecurity Technical Support for assistance.
ERROR	ERROR 8 RPM SENSOR	3 chirps per second once per minute	RPM sensor disconnected.	Check wiring from the hydraulic cylinder to the STC.
ERROR	ERROR 9 BATT DISCONNECT	3 chirps per second once per minute	Only applies to DC Power Supply connection. Smart Touch Controller detects no battery connected. Batteries are disconnected, or a wiring fault exists. Replaced by Alert 29 in h5.57 software version.	<ol style="list-style-type: none"> 1. Ensure red wire in upper left corner of control box is connected to switch. 2. Correct any issues with battery wiring. 3. Check 35 amp fuse on circuit board.

Type	Alert/Fault/Error Display	Buzzer Chirp Sequence	Possible Cause &	Solutions
ERROR	ERROR 10 SLOWDOWN SWITCH	3 chirps per second once per minute	VFD only. The operator tripped the fully Open or Close limit before the Slowdown limit tripped. Check: Slowdown limit wiring and adjustment Adjustment of the limit ramps to verify that the limit switch is being tripped. Manually trip the slowdown limit. OPEN SLOWDOWN or CLOSE SLOWDOWN should appear on the display which indicates that it is working properly.	
FAIL	FAIL Program Data Err FAIL	3 chirps per second once per minute	Try turning off the power to the operator and having the customer re-seat all of the various connectors and cables. Upload the latest software release. If the fail does not go away, contact Technical Support.	

ACCESS THE EVENT LOG THROUGH THE USER MENU

NOTE: While you are viewing the event log, the gate operator is in Menu mode and cannot run open or close.

- To enter the User Menu, press the Menu key twice.
- Press Next and scroll until "LG 0 (OFF)" appears in the display.
- Press Select. LG blinks.
- Press Next to change the number to 1,
LG 1 (ON)
VIEW EVENT LOG
- Press Select. The most recent event recorded in the log appears.
- To scroll through the event log, press Next or Prev.

NOTE: Hold down Next or Prev to scroll quickly toward the top or bottom of the event log.

- To exit, press Menu. The display resets to LG 0 (OFF).
- Press Menu again to exit the User Menu and return to Run/Program mode.

Month / Day	Time (HH:MM)	Event Type
03/17	15:27	ALE5
Description: ALERT 5: BOTH LIMITS TRIPPED		

NOTE: Over 300 events can be recorded before the software begins overwriting the existing log history.

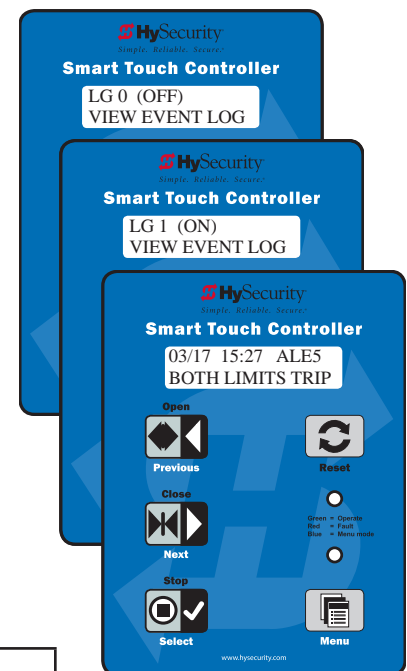

The event log is also accessible through S.T.A.R.T. software with the use of a PC laptop and interface cable. Refer to the [S.T.A.R.T. User Guide](#).

ELECTRICAL ISSUES

A general set of troubleshooting procedures are provided in the following paragraphs. Use a voltmeter to take the measurements described in the steps. If at any point in the process, a result different than what's expected occurs, stop and identify the problem.

AC-Powered Gate Operators

PROBLEM 1: Pushed the OPEN and CLOSE button, but the motor is not running.

1. Verify the incoming voltage and phase at the incoming power terminals matches the voltage and phase on the nameplate of the motor. They must match!
2. Verify the 24VAC transformer has the proper connection to the incoming power (the black wire is always connected); White – 115VAC*, Red = 208VAC, Orange = 230VAC, Blue = 480VAC.
3. Verify the primary tap wires match line voltage connected to operator. Measure the line voltage carefully to distinguish between 208V and 230V branch circuits or between 390V and 460V branch circuits. A label on top of the transformer identifies the various voltage taps. This connection must match the voltage on the operator nameplate.

NOTE: Primary taps do not exist on battery operators.

4. Verify the 24VAC is present at the Red and Green wires from the control transformer to the Power Supply Board by measuring the bottom of the power supply board at the -ACC+ connectors.
5. Verify that the main power wires are at least the minimum wire size specified in “Wire Sizing and Runs” on page 24. Be certain that the branch circuit wire size versus the distance of the run from the main panel is large enough to avoid excess voltage drop.
6. Verify 24VDC power is present on the Power Supply Board between the +24VDC terminals above the terminal strip and any screw connection on the terminal strip.
7. Be sure a 20A circuit (protected with a 20A inverse time breaker) is provided.
8. Check and make sure the operator is electrically grounded per NEC Article 250 and local codes.
9. Verify the 24VDC is present at the +24VDC and common terminals located along the lower edge of the Smart Touch Controller board. (RADIO OPTIONS, etc.)
10. Verify that the “Heart Beat” LED is blinking green.
11. Verify the display is operational on the LCD and VFD display.
12. With the knowledge that the power is correct and the electric motor runs, check the STC display. If an error, alert or fault code appears, refer to *Table 8: Troubleshooting Codes* on page 107 to determine possible resolutions.

(This page intentionally blank)

MECHANICAL ISSUES

Gates that run smoothly and operate well significantly improve the life of the gate operator's motor and component parts. Refer to *Mechanical Maintenance* on page 105.

On site gate movement issues can usually be resolved in the short term by manually moving the gate open and close. Refer to *Manual Release Option* on page 9.

HYDRAULIC ISSUES

The speed at which the operator moves the gate is determined by the size of the hydraulic pump and software settings.



Attempting to slow gate speed by changing a valve setting will cause inefficiency and increased heating of the hydraulic system, which will degrade system performance and also may result in premature system failure.

NOTE: If the gate speed must be changed, contact your HySecurity distributor or HySecurity Tech Support.

Extremely cold weather is unlikely to seriously affect the gate speed because HySecurity employs a special grade of hydraulic fluid (Uniflow), which maintains a linear viscosity over a broad temperature range. This high quality fluid, combined with other design considerations, allows HySecurity to rate its operators for service in ambient temperatures of -40°F to 158°F (-40°C to 70°C).

If the gate speed of your operator has been affected by cold weather, perform the following:

1. Verify the gate hardware is not impaired by ice.
2. Verify that the reservoir is filled with Uniflow fluid.

NOTE: Consider adding a heater in extreme cold weather regions. A biodegradable fluid option does exist, but it does not have the same fluid viscosity at extremely low temperatures. The biodegradable fluid option has a temperature rating between -10°F and 158°F (-23°C and 70°C).

TYPICAL PROBLEMS AND TROUBLESHOOTING PROCEDURES

A few typical problems and their associated troubleshooting procedures are provided to facilitate identification and resolution.

PROBLEM 1: Pressing the Open and Close buttons produce no response (nothing happens).

1. Verify the line voltage is present and matches the operator's input voltage requirement + 10%.
2. Verify the control voltage is present at the Power Supply Common and 24VDC terminals. It may be necessary to reset the circuit breaker (black button) on the transformer.
3. If an external Stop button is not used, verify a jumper wire connects Common to Stop.
4. Verify there are no Faults or Errors being reported on the LCD display.
5. Jump COM to the OPEN or CLOSE INPUT and verify that the LED lights on the STC board which indicates that the input is active and working properly. To help in diagnosing the problem, take note of what other inputs light up and check the display for codes.
6. Verify there are no active safety device inputs.

PROBLEM 2: Hydraulic pump is running and the hydraulic pressure is between 0 - 1200 PSI, but the gate is not moving. The Smart Touch Controller reports system malfunctions on its LCD display and the buzzer will emit a series of chirps at defined intervals. Review the table of Alerts, Faults and Errors listed in *System Diagnostic Messages* on page 106. To check the status of all inputs on the terminal strip, the LED tact button must be pushed. If the power is three-phase, verify counter-clockwise electric motor rotation. To reverse rotational direction, switch any two AC lines.

NOTE: The VFD Motor Controller displays trip and fault codes. Check to see if any error codes appear on the VFD display. Most VFD issues are resolved through the STC software and modbus interface.

1. Check the hydraulic fluid level by removing the plug in the pump reservoir. If necessary, add fluid at this location until the level is about ½ inch below the filler hole.
2. Unplug the hydraulic hoses and run the pump; if the pressure is low, adjust the Pressure Relief Valve.
3. If the Pressure Gauge does not respond to adjustment of the Pressure Relief Valve, you may need to completely remove the valve, depress the plunger at the nose end with a blunt tool (e.g., a hex key) and blow on it to remove any debris. Contact HySecurity Technical Support first (see page 2) before performing this procedure.

PROBLEM 3: The gate only opens or only closes.

1. Verify that no external device is commanding the gate to open or close by watching the LEDs associated with each input.
2. If the gate only opens, rotate manual override to release open valve, and then check valve for debris or damage.
3. If the gate only closes, the Solenoid Coil may not be energizing or it may be defective.
4. Carefully, replace the valve.

PROBLEM 4: A run command causes PEC to appear on display.

1. Check that the photo eye is not blocked. If it is, remove the blockage and realign the photo eye. Refer to *Photo Eye Alignment Feature* on page 88.
2. If you have a battery-powered photo eye, check that the batteries are viable and fresh.
3. If needed, realign the photo eye.

PROBLEM 5: A run command causes PEC to appear on display.

1. Check that the photo eye is not blocked. If it is, remove the blockage and realign the photo eye. Refer to *Photo Eye Alignment Feature* on page 88.
2. If you have a battery-powered photo eye, check that the batteries are viable and fresh.
3. If needed, realign the photo eye.

PROBLEM 6: I have a bi-parting gate system or twin models and the gate panels won't synchronize.

1. Follow steps on page 29. Verify the *Open Position and Hydraulic Hose Swap*.
2. Air trapped in the hydraulic system hoses can cause slow or jerky movement and prevent the panels from synchronizing.

PROBLEM 7: The gate panels move very slowly and seem to shudder throughout gate travel.

1. Follow steps on page 29. Verify the *Open Position and Hydraulic Hose Swap*.
2. Verify settings *Adjusting the Pressure Relief Valve* on page 31.

PROBLEM 8: Gate speed in extremely cold weather

Extremely cold weather is unlikely to seriously affect the speed of the gate, because HySecurity employs a special grade of hydraulic oil which maintains a very linear viscosity over a broad range of temperatures. Because of this high quality oil and other design considerations, we rate our operators for service in ambient temperatures of - 40°F to 158°F (- 40°C to 70°C). If the speed of your operator has been affected by cold weather, verify that the gate hardware is not impaired by ice and verify that the reservoir it is filled with UNIFLOW oil.

General Maintenance

SMART TOUCH ANALYZE AND RETRIEVE TOOL (S.T.A.R.T.)

HySecurity provides Smart Touch Analyze and Retrieve Tool (S.T.A.R.T.) software to help HySecurity gate operator users and installers conduct the following field service activities:

- Configure installer and user menu settings
- View the operator history (event) log
- Display monitored inputs for operator diagnostics
- Load Smart Touch Controller (STC) software



With S.T.A.R.T. software loaded on your laptop computer, you have an invaluable management tool for all HySecurity operators. The RS-232 serial port (found on the Smart Touch Controller), allows you to download system diagnostics and upload system configurations using the S.T.A.R.T. software. The free S.T.A.R.T. software is conveniently located at www.hysecurity.com. Instructions for downloading S.T.A.R.T. are on the website.

What You Need

HySecurity Serial RS-232 communication cable with USB adapter and current USB driver.

- Standard USB 2.0 A-B communications cable. If you are using the HySecurity RS-232 to USB adapter, be sure to install the USB driver in your laptop.
- Laptop computer with Windows PC operating system (XP, Vista, Win7/8/8.1/10)
- Minimum 128MB of RAM
- Minimum 5MB of hard drive disk space
- VGA graphics card (minimum resolution of 800 x 600)

Installing S.T.A.R.T. Software

Read the [S.T.A.R.T. User Manual](#), and then take the following steps to download S.T.A.R.T. software:



The latest version of S.T.A.R.T. is encrypted. An error message will appear stating that the file is corrupt if you try to load new operator code using out-dated S.T.A.R.T. software. Be sure to “uninstall” any outdated versions of S.T.A.R.T. from your laptop and install the latest version from www.hysecurity.com.

1. Bring up your web browser and type <https://www.hysecurity.com> in the command line.
2. Click Technical Support (left column) on the HySecurity home page.
3. Click Download: Smart Touch software.
4. Enter your user name and password. If you do not have a user name, register as an online member.
5. Click S.T.A.R.T. Software for Smart Touch and SmartDC to begin the software download.

6. Read the End User License Agreement and, if you agree to the terms, click, "**I accept**" (bottom of page).
7. Save the START< >_setup.exe file to your desktop.
8. Double-click the file to begin the installation.
9. Click RUN. A setup window appears.
10. Follow the step-by-step instructions to complete the installation.*
11. When the download is complete, log off the HySecurity website. Shortcuts for the S.T.A.R.T. and STC History Logs should appear on your laptop's desktop.*

***NOTE:** Confirm you have administrative rights by clicking the following on your computer screen: Windows start ->Control Panel ->User Accounts ->User Accounts. See if your name appears as an administrator. If you are the only user of a computer, you are by default the administrator. If not, you may need to consult with your company's system administrator prior to downloading the HySecurity S.T.A.R.T. program.

SOFTWARE MAINTENANCE

STC board software is constantly being enhanced with new features that create an easier install and improve on board diagnostic tools. Check the HySecurity website for a test version of software before heading out for field maintenance.

Use S.T.A.R.T. software to download latest software version to a PC laptop and upload it to gate operator in the field.

NOTE: If site includes a bi-parting gate system, make sure software version used in Primary and Secondary operators is identical.

ELECTRICAL CONTROLS

NOTICE: Before servicing, turn off all power switches.

No routine maintenance is needed for the electrical system or controls. If the environment is very sandy or dusty, or has many insects, be certain to seal all holes in the electrical enclosure. Blow the dust out of the electric panel with compressed air. Use the *Table 8: Troubleshooting Codes* on page 92 to assess and fix error, alert, and fault codes. If it is necessary to call a distributor for assistance, be sure to have your model and serial number ready. Other helpful information includes the name of the job, approximate date of installation, and the service record of the operator, especially if any work has been done recently.

Clock Battery Replacement

A lithium coin battery supports the clock, so the date and time is retained even when the main power is turned off. Replace the battery about every five years (or as needed) with a DL 2025, DL 2032, or CR 2025, or CR 2032 battery.

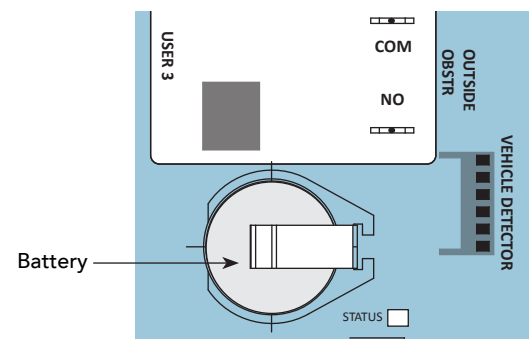

MECHANICAL MAINTENANCE

NOTICE: Before checking the internal mechanisms of the operator, turn off all power switches.

The mechanical maintenance for the HydraSwing is not in depth or difficult, but should be performed on a routine basis.

Schedule regular maintenance:

- ✓ Check condition of hydraulic hoses and fittings, check for abrasion and cracking..
- ✓ Check for signs of rust. The operator chassis is zinc plated which is corrosion-resistant, but some environments may increase the rate of corrosion. If any areas of rust are found, reduce the spread of corrosion by treating the areas with a rust inhibitor.
- ✓ Grease the large cylinder (80/150 models) or small cylinder (40/40F/Twin models) per the chart on page 126. Use NLGI #2 Grade Moly EP (Extreme Pressure) lithium base grease only and apply it with a standard grease gun.
- ✓ Replace worn-out batteries.
- ✓ Maintain gate hardware in good-working order.

HYDRAULIC SYSTEM MAINTENANCE

Fluid Level: Under normal conditions, hydraulic systems do not consume fluid. Check the system thoroughly for leaks, before adding any fluid. If fluid needs to be added:

1. Move the gate so the cylinder is retracted.
2. Remove the metal plug from the tank.
3. Use HySecurity Uniflow hydraulic fluid; part number MX000970. Gallon sold through distributors.
4. Fill to within ½ inch of the plug level, and then replace plug.

NOTICE: Never use brake fluid. It will severely damage the hydraulic system. Use of any fluid other than fluid recommended by HySecurity may void the operator warranty.

Look for leaks: Occasionally there may be slight seeping at the fittings after some usage. Tightening of the fittings usually corrects the problem. If leaking persists, replace "O" rings, fittings or hoses, if required. No further leaks should occur.

To Change Fluid: Unlike a gas engine, the fluid inside a hydraulic system does not foul, so fluid changes do not need to occur often. HySecurity recommends draining the reservoir and replacing the fluid at five-year intervals. Fluid breakdown caused by heat is the main concern. If the unit is subjected to high use, or you are using the HySecurity biodegradable fluid option (especially in a warm climate), change the fluid more frequently.

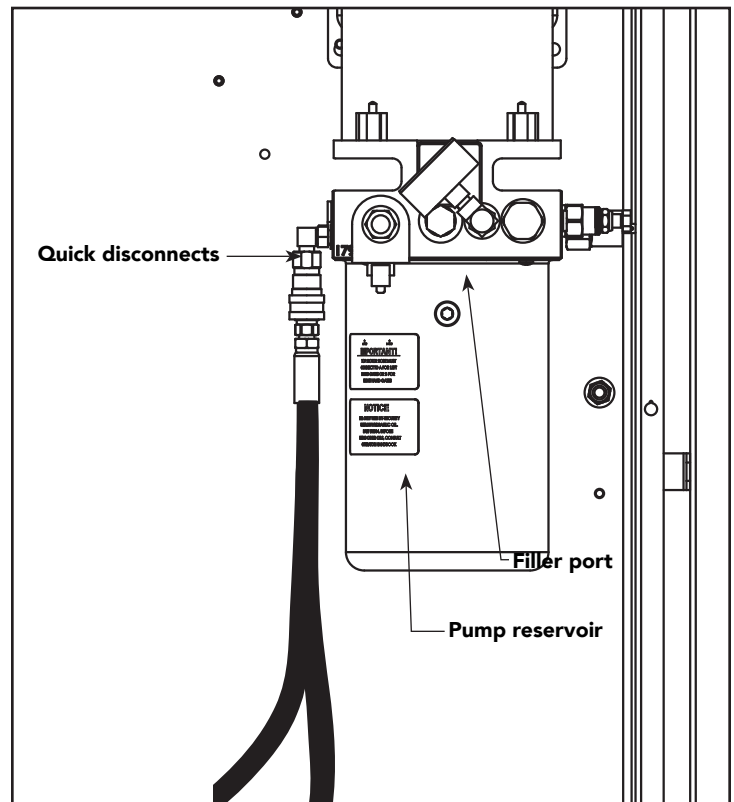

To change the hydraulic fluid,

1. Position the gate so the cylinder is fully retracted.
2. Remove the reservoir from the pump pack.
3. Completely empty it.
4. Wipe the reservoir clean and clean the debris screen.
5. Re-assemble the pump unit and refill it with new Uniflow hydraulic fluid.
6. To avoid overfilling, slowly pour the fluid through the filler port near the reservoir's top until the fluid is within ½ inch of the port's opening.
7. Replace the plug and wipe up any spilled fluid. Spilled fluid dries to a sticky and messy consistency.

Cold Weather Issues:

1. Check that your reservoir is filled with our Uniflow high performance fluid.
2. Excessive ice buildup can partially or totally jam gate operation. Operate the gate manually, while clearing the ice buildup.
3. If the operator is located in an area of extreme snow conditions, regular maintenance to dig the operator out may be required. A heater option may help.

NOTE: A biodegradable fluid option does exist, but it does not have the same fluid viscosity at extremely low temperatures. Uniflow fluid temperature rating is between -40°F and 158°F (-40°C and 70°C). The biodegradable fluid has a temperature rating between -10°F and 158°F (-23°C and 70°C).

Brake Valve Adjustments



The contents of the hydraulic cylinder are under pressure. Close the gate prior to making any brake adjustments or disassembly to the manifold connected to the hydraulic cylinder. Failure to close the gate may result in personal injury.

Proper adjustment of the brake valves is important for smooth operation of the gate.

Adjustment of the brake valves, one for each direction of travel, will determine how quickly the gate actually stops. Heavy, long gates will need more brake adjustments than smaller, lighter gates. If adjustment is needed, loosen the ¼-inch lock nut on the top of the brake valve and make ¼-inch incremental turns on the adjustment stem with a 5/32 hex key.

The adjustment is counter-intuitive.

If the gate passes its learned limit point, a counter-clockwise adjustment stops the gate more rapidly. If the adjustment is set too tight, the system pressure will increase, the gate speed may decrease, the gate will jerk to a stop, and the IES may trip.

Brake valves are factory-set to midpoint, two turns. This should be sufficient for most applications. When the adjustment is complete, re-tighten the ¼-inch lock nut to hold the setting.

Brake valve adjustment instructions are on the following page.

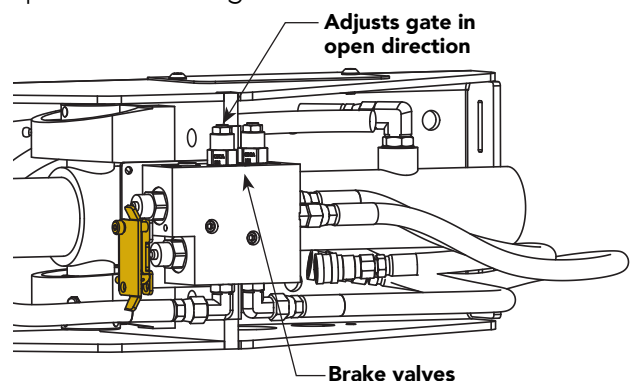

BRAKE VALVE ADJUSTMENT INSTRUCTIONS:

There are two brake valves on each actuator. Adjust as follows:

1. The initial adjustment is 2 turns counterclockwise on all except the furthest close brake valve.
2. The furthest close brake valve is set to 1.75 turns counterclockwise. This is done by loosening the 9/16" lock nut and gently turning the 5/32 hex key all the way clockwise, then next turning counterclockwise while counting the turns. The goal is to make the gate furthest from the HydraSupply slightly faster.
3. If a tighter break (more turns counterclockwise) is required to hold against windy conditions, then adjust all brake valves out an equal amount.
4. The furthest close brake is adjusted slightly ¼ turns less than the others. This adjustment can vary depending on hose length.

Pressure Relief Valve Adjustments

The Pressure Relief Valve governs the maximum system hydraulic pressure. It is located on the backside of the pump. The pressure relief valve is factory set and may need to be adjusted depending on the gate weight.

Pressure relief valve adjustments establish the threshold for the inherent entrapment sensor (IES). The optimal pressure setting produces uniform gate travel and trips the IES when the gate encounters an obstruction.

Refer to *Adjusting the Pressure Relief Valve* on page 25 and follow the instructions.

For HySecurity Technical Support contact: 800-321-9947.

Open Valve

The open valve is solenoid operated and, when energized, directs the hydraulic flow to open the gate. No adjustment of this valve is possible or necessary. The black solenoid coil mounts on its valve stem.

HydraSwing Hydraulic Cylinder Maintenance

The hydraulic cylinder requires little maintenance other than applying NLGI #2 Grade Moly EP (Extreme Pressure) lithium base grease to zerk fittings at the intervals shown in the table on the following page.

NOTE: To apply grease, the gate must be in the Open position.

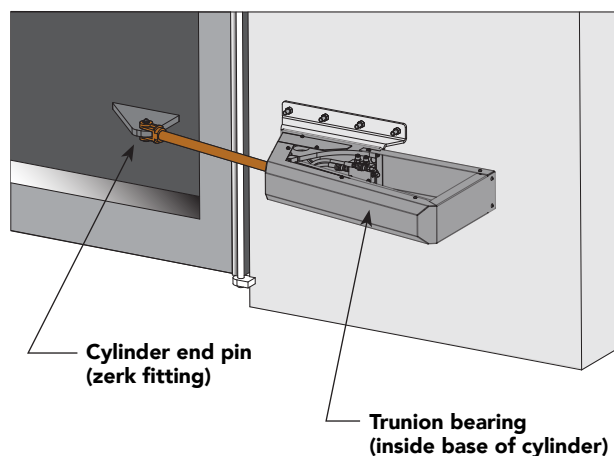
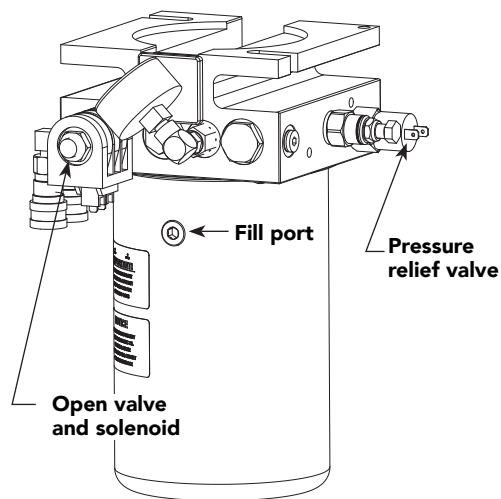

HYDRASWING OPERATOR MAINTENANCE SCHEDULE

Name of part	What to do	Weekly	Check at these recommended monthly intervals				
			1	3	6	12	24
Gate and hardware	Check for damage and wear *1	X	X				
Anchor bolts & fasteners	Check and tighten, if loose. If fasteners are worn, replace. *2	X			X		
Cylinder	Apply grease to zerk fittings *2				X		
Large Hydraulic cylinder	Grease end pin (50,000 cycles) *3					X	
Hydraulic cylinder (inside)	Grease ball bearings (100,000 cycles) *4					X	

Special Notes:

- *1. Your gate and gate hardware requires maintenance. A damaged gate or worn hardware may cause slow or erratic operation and will result in excess drive wheel wear. Lubricate gate hardware more frequently and check for smooth operation by opening the toggle clamping mechanism and then pushing the gate manually. One person should easily be able to push all but the largest of gates. Damaged or warped gate panels should be straightened or replaced.
- *2. Grease the hydraulic cylinder zerk fittings every 50,000 cycles. Use NLGI #2 Grade Moly EP lithium base grease only and apply with a standard grease gun.
- *3. Grease the large hydraulic cylinder end pin as regular maintenance every 50,000 cycles or 1 year (whichever comes first).
- *4. Grease the two zerk fittings on the hydraulic cylinder trunion bearing (inside, near base of the cylinder) regularly, every 100,000 cycles or 1 year (whichever come first).

HYDRASUPPLY MAINTENANCE SCHEDULE

Name of part	What to do	Weekly	Check at these recommended monthly intervals				
			1	3	6	12	24
Inspect power unit	Cycle test several times. Listen for unusual sounds or vibrations.		X				
Bolts & fasteners	Check and tighten, if loose. If fasteners are worn, replace.	X					
Fluid level	Remove fill plug and check for loss of fluid. *5		X			X	
Fluid leaks	Check all hose connections *6		X				
Hydraulic fluid	Drain and replace fluid (500,000 cycles, or as needed)		X				
Hoses	Check condition and QDs		X				
Pressure gauge	Verify normal pressure		X				
Inspect Control Box	Visually look inside Control Box. Check for worn wires. Repair wires, remove debris.				X		
Clock Battery	Replace *7						X
Motor Brushes (DC Only)	Replace *8						X
Sensors and IES	Check photo eye or edge function and verify the IES (Inherent Entrapment System) functions correctly. See page 37.						

Special Notes:

- *5. Fluid Level – Check fluid level weekly. Drain and re-fill reservoir at least once a year or as cycle count dictates.
- *6. Fluid leaks – Check for signs of fluid leaks at cylinder and connections inside the HydraSupply. Loss of fluid is not normal and indicates a leak that must be located and repaired.
- *7. Replace the Smart Touch Controller coin battery with DL 2025 / DL 2032 or CR 2025 / CR 2032.
- *8. Check the motor. DC motors contain carbon brushes which wear over time and must be replaced. Failure to replace the brushes will result in damage to the DC motor. Brushes should be inspected every year in high usage applications or every 100,000 cycles and replaced as needed.

Wiring HySecurity Sensors: Smart Touch

Wiring diagrams are provided on the following pages. The diagrams illustrate how to connect sensors and program the gate operator. HySecurity Smart Touch gate operators can monitor entrapment protection sensors per UL 325 - 2016 Standard of Safety using software version h4.50 (or later).

The site designer or installer must determine which external entrapment protection sensors will be installed with the gate operator to create a UL 325 compliant installation site. For additional information, review [Gate Safety on the HySecurity website](#).

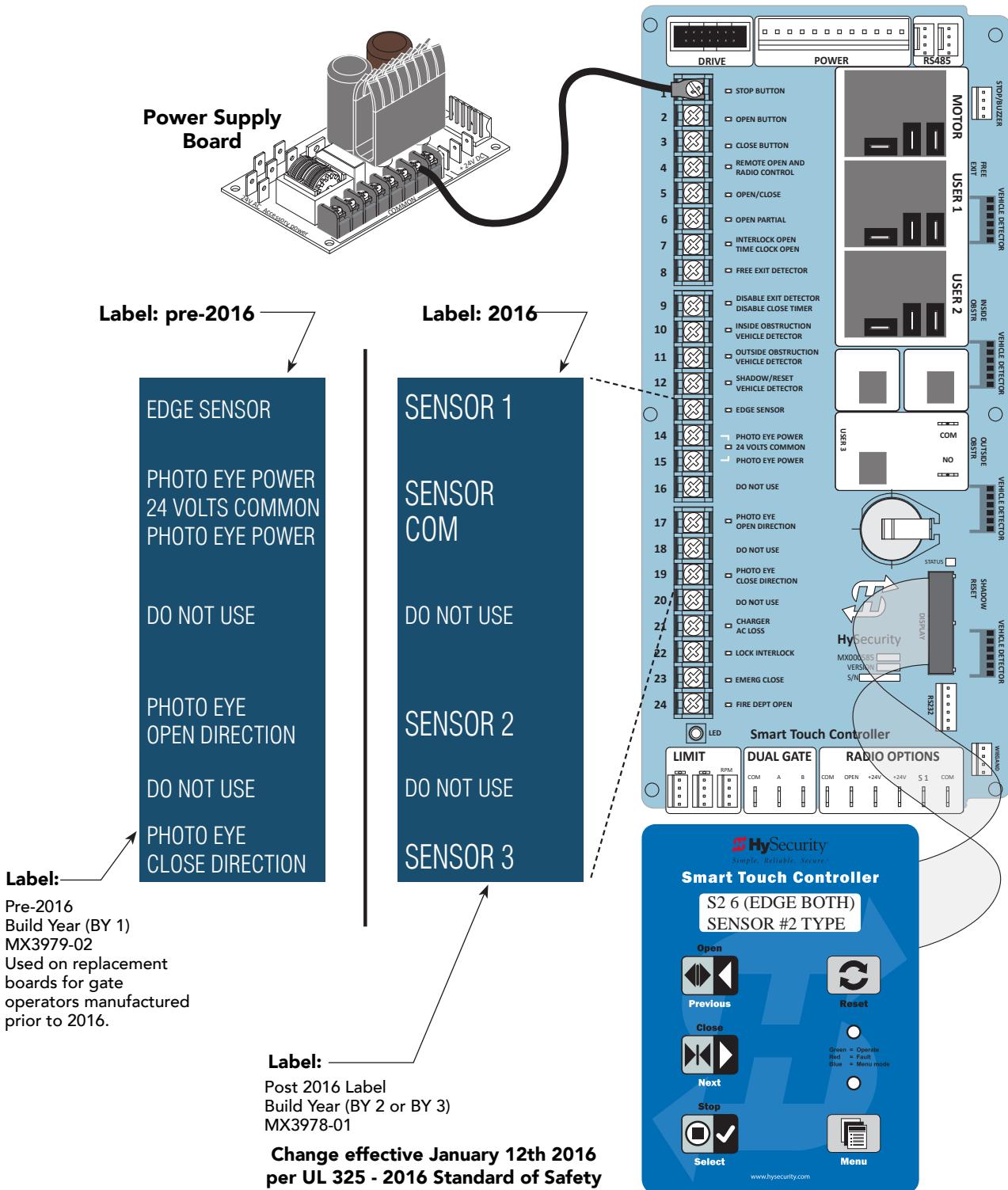

WIRING TIPS FOR SENSOR COM TERMINAL: SMART TOUCH

Two SENSOR COM terminals exist (Terminal 14 and Terminal 15). If using multiple sensor devices, use a wire nut as a junction and pigtail to SENSOR COM. Or, install a separate terminal block and jumper outputs to one lead for either SENSOR COM terminal.



All external entrapment protection sensors must be NC sensor outputs and wired to the SENSOR COM terminal for monitoring and powering purposes. The sensor becomes actively powered when the gate operator receives a run command.

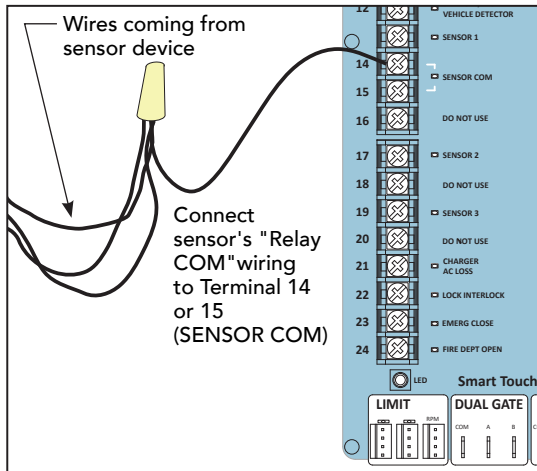

Wire nut and pigtail to SENSOR COM

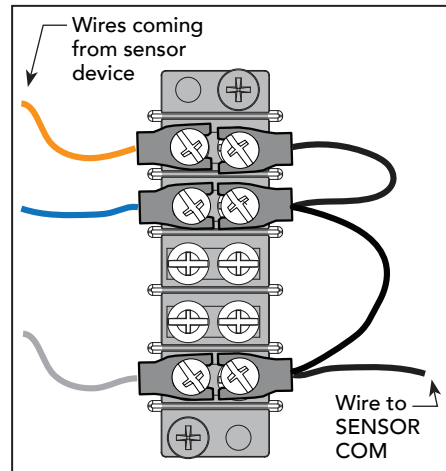

Add terminal block

NOTE: LEDs next to the sensor connections will be lit when NO POWER is being applied. To temporarily supply power to the sensors. Refer to *Photo Eye Alignment Feature* on page 88. When PE is turned ON, the LEDs turn off. If they do not turn off, check for wiring issues such as a short or misapplied relay COM connections. Refer to *Supply Power to the Sensors* on page 34.

MENU MODE NAVIGATIONAL TIPS

Press the Menu button twice to access Menu mode. The gate will not run while in Menu mode. The buttons on the display keypad perform certain functions while in Menu Mode. Refer to the chart.

To change data appearing in the display	To navigate through the Selections	To choose what appears on the display	To navigate between menu items
Press Select . Two left characters blink.	Press Next or Previous . Continue pressing Next to view all selections.	Press Select . Blinking characters become static.	Press Next or Previous . Advance - press Next Previous - press Previous

SMART TOUCH: 2 CH WIRED EDGE WITH HY2NC

The wiring diagram illustrates a WIRED edge receiver connected to the STC controller via the 2 channel Wired Edge Sensor N/C adapter Hy2NC™.

NOTE: Turn OFF AC power before connecting sensor wires to the Smart Touch Controller.



Connect all contact and non-contact sensors to same power source. Example, Do NOT connect photo eyes to +24VDC and gate edges to +12VDC. Incompatible electricity flow. A FAULT 2 will appear.



All external entrapment protection sensors must be NC sensor outputs and wired to the SENSOR COM terminal for monitoring and powering purposes. The sensor becomes actively powered when the gate operator receives a run command.

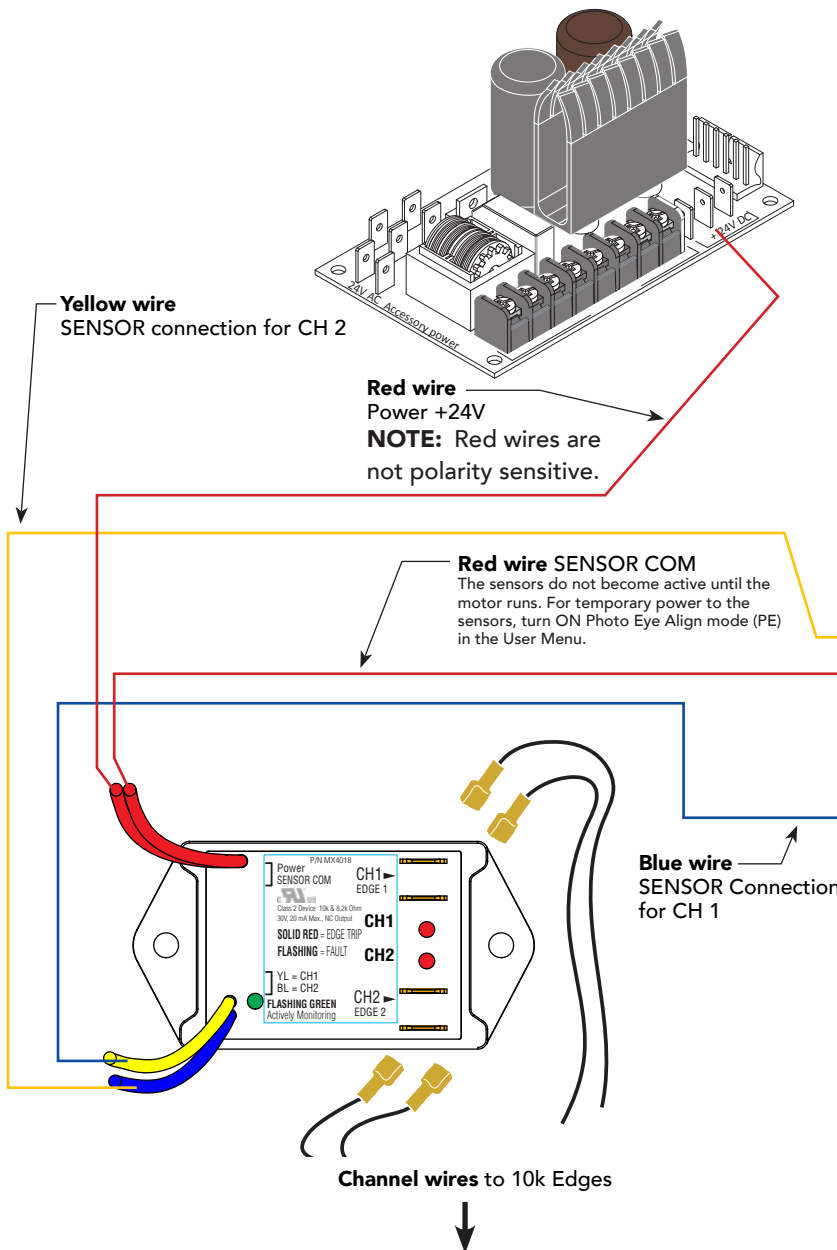

Sample: Installer Menu Settings

Smart Touch Controller
S1 0
SENSOR #1 TYPE

Open

Smart Touch Controller
S1 6 (EDGE BOTH)
SENSOR #1 TYPE

Open

Smart Touch Controller
S2 0
SENSOR #2 TYPE

Open

Smart Touch Controller
S2 3 (EDGE CLOS)
SENSOR #2 TYPE

Open

SMART TOUCH: PHOTO EYE THRU BEAM (EMX IRB MON)

1. Connect photo eye wiring.

NOTE: Run a jumper between photo eye -24V (POWER INPUT) and COM terminals on the Receiver.

2. Turn ON power.
3. Access the Installer Menu and configure SENSOR setting according to the entrapment area that the photo eye is monitoring. Refer to table on page 40.

***NOTE:** Make sure whichever wired input used (SENSOR 1, 2, or 3) is the same Sensor # configured through the Installer Menu.

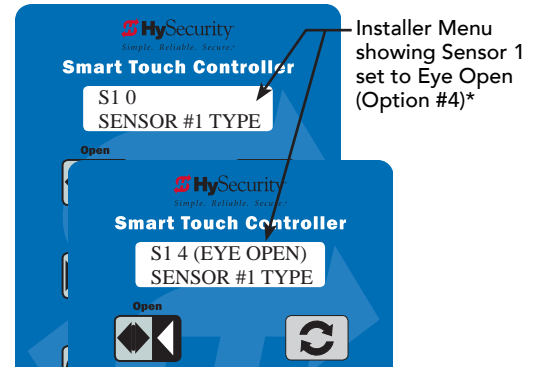

EMX IRB MON Photo Eye Transmitter

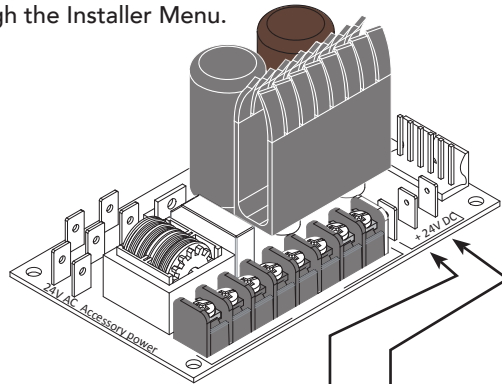

Power Supply Board

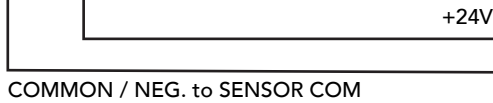

EMX IRB MON Photo Eye Receiver



CAUTION
Set DIP Switches
1 = OFF
2 = OFF
3 = OFF
4 = ON

Jumper POWER INPUT - 24V to COM

COMMON / NEG. to SENSOR COM

NC Relay

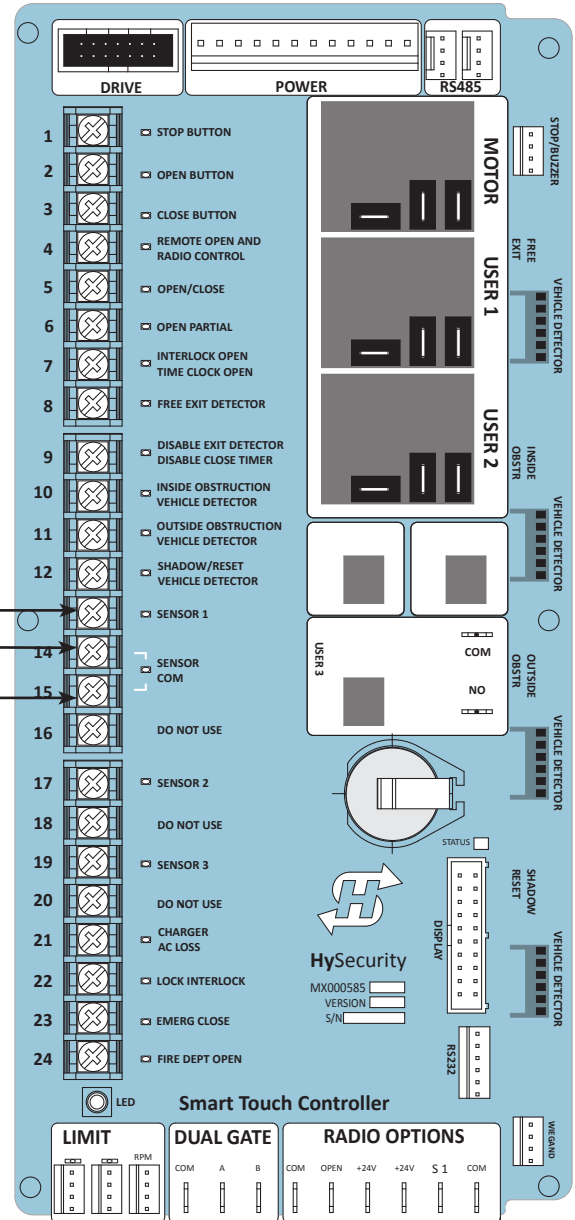

CAUTION

DIP switches must be set as shown otherwise the photo eye will not operate correctly. If you receive an Alert, "!ACTION BLOCKED" "Photo Eye Open" PEO or "Photo Eye Close" PEC, take steps to align the photo eye. Refer to *Photo Eye Alignment Feature* on page 88.

SMART TOUCH: PHOTO EYE / REFLECTIVE (E3K R10K4)

1. Set Photo Eye switch to LIGHT ON. See NOTE.
 2. Connect photo eye wiring.
- NOTE:** Run a jumper between photo eye -24V and Relay COM (C2) terminals. See photo.
3. Turn ON power.
 4. Access the Installer Menu and configure SENSOR setting according to the entrapment area that the photo eye is monitoring. Refer to table on page 40.

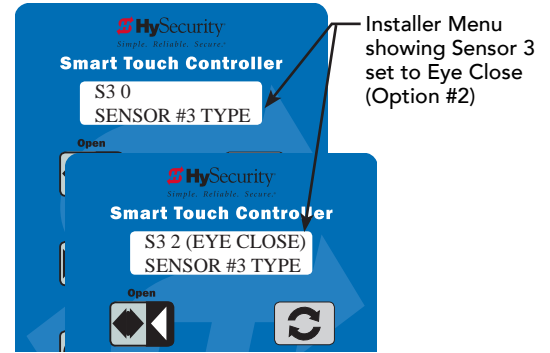

CAUTION

All external entrapment protection sensors must be NC sensor outputs and wired to the SENSOR COM terminal for monitoring and powering purposes. The sensor becomes actively powered when the gate operator's motor runs.

Power Supply Board

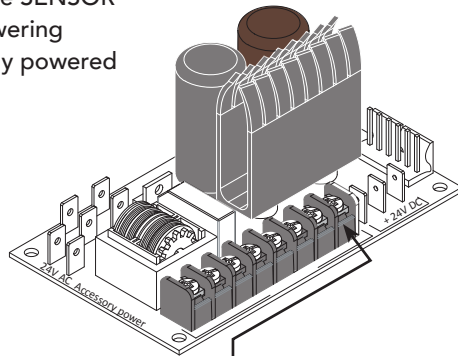

Omron (E3K R10K4) Reflective Photo Eye

NOTE: Light/Dark switch must be set to LIGHT ON.



CAUTION

Do NOT connect the 10K resistor to HySecurity gate operators. Follow the instructions on this sheet to avoid FAULT 2.

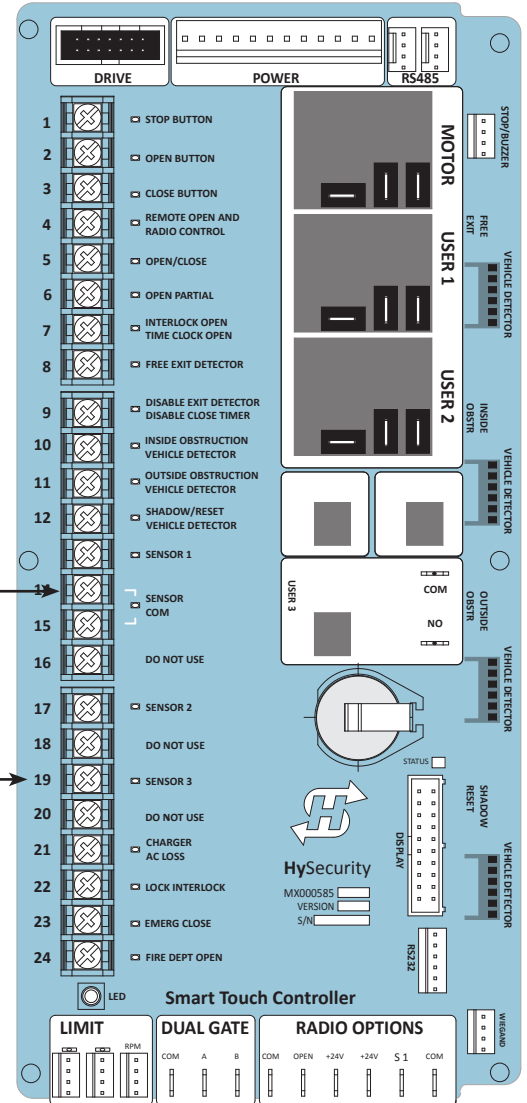
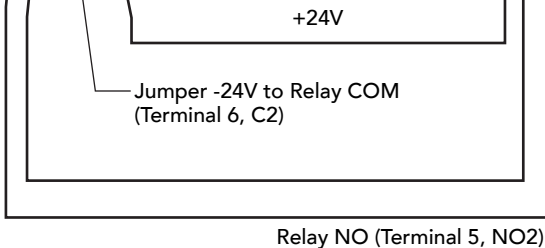

NOTE: If you receive an Alert, "!ACTION BLOCKED" "Photo Eye Open" PEO or "Photo Eye Close" PEC, take steps to align the photo eye. Refer to *Photo Eye Alignment Feature* on page 88.

SMART TOUCH: THE SOLUTION, MIM-62 (MULTI-INPUT MODULE)

1. Turn OFF AC power.
2. Input channels 1 and 2 must be used and are always assigned to OUTPUT A.
3. All other input channels may be configured to either A or B.
NOTE: If different sensor types are connected to the same output, then program the Controller SENSOR type for EDGE options.
4. Turn ON power.
5. Access the Installer Menu. Configure SENSOR setting according to the types of sensors wired to the Smart Touch Controller.

Power Supply Board

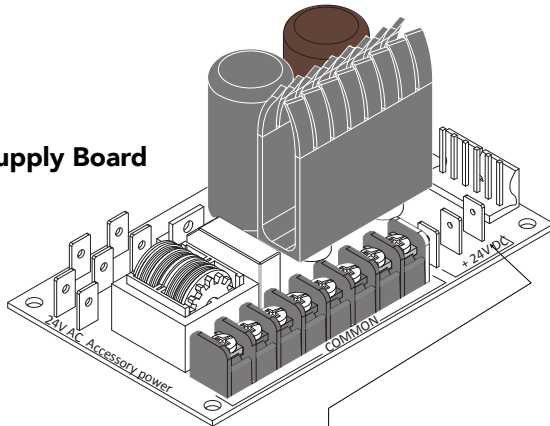

Connect either output (P/NC wire) to SENSOR 1, 2, or 3.

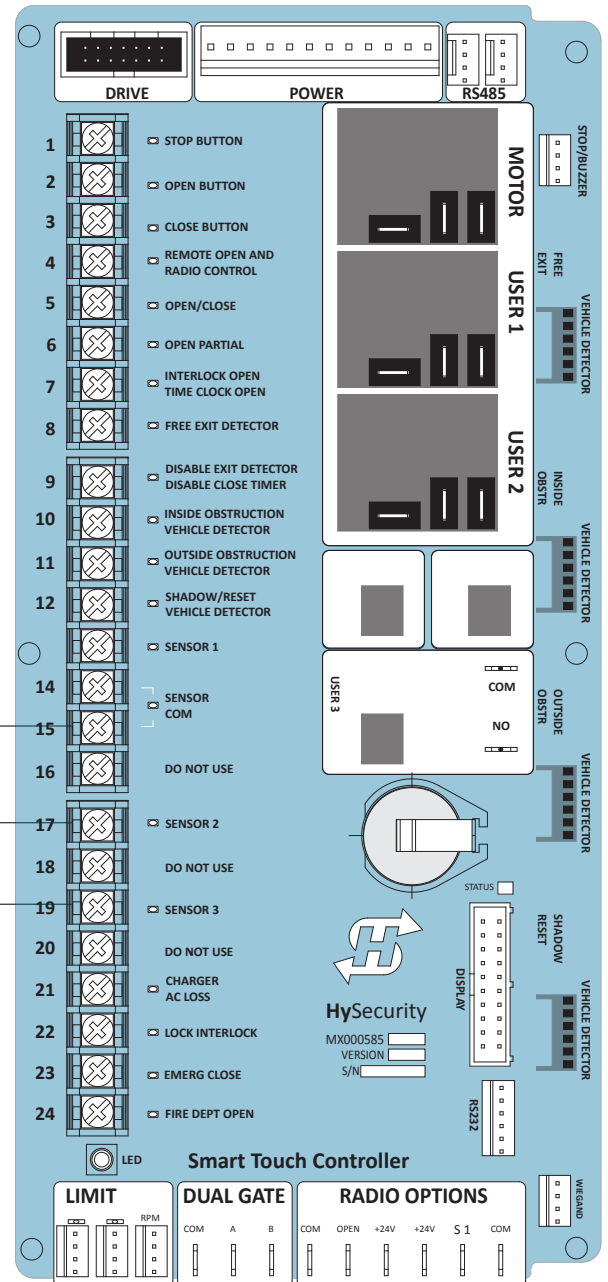
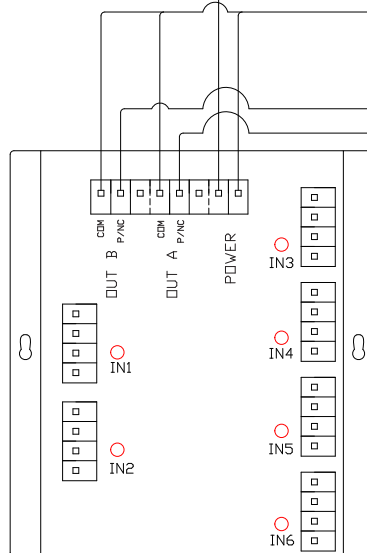

All external entrapment protection sensors must be NC sensor outputs and wired to the SENSOR COM terminal for monitoring and powering purposes. The sensor becomes actively powered when the gate operator's motor runs.

SMART TOUCH: WIRELESS EDGE, WIRELESS GATE LINK

A transmitter (MGL-TX20) and receiver (MGLRX20) are required.

Installer Menu showing SENSOR 2 set to EDGE OPEN (Option #5) and SENSOR 3 set to **EDGE CLOSE (Option #3)**

1. Turn OFF power.
2. Connect the wiring per the diagram shown.
3. Turn ON power and access the Installer Menu.
4. Configure SENSOR setting accordingly (i.e. Edge Open, Edge Close, or Edge Both). Refer to table on page 40.

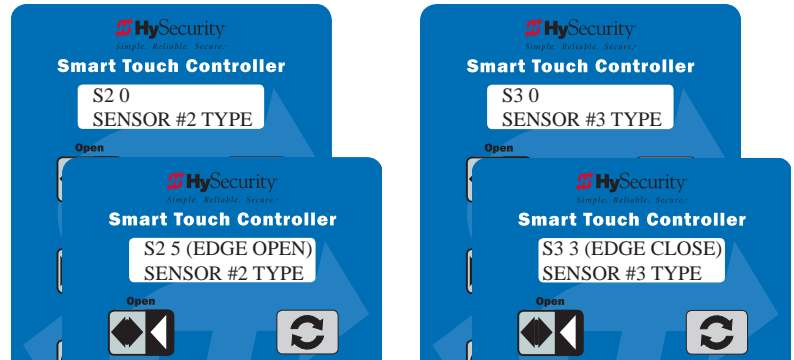

Power Supply Board

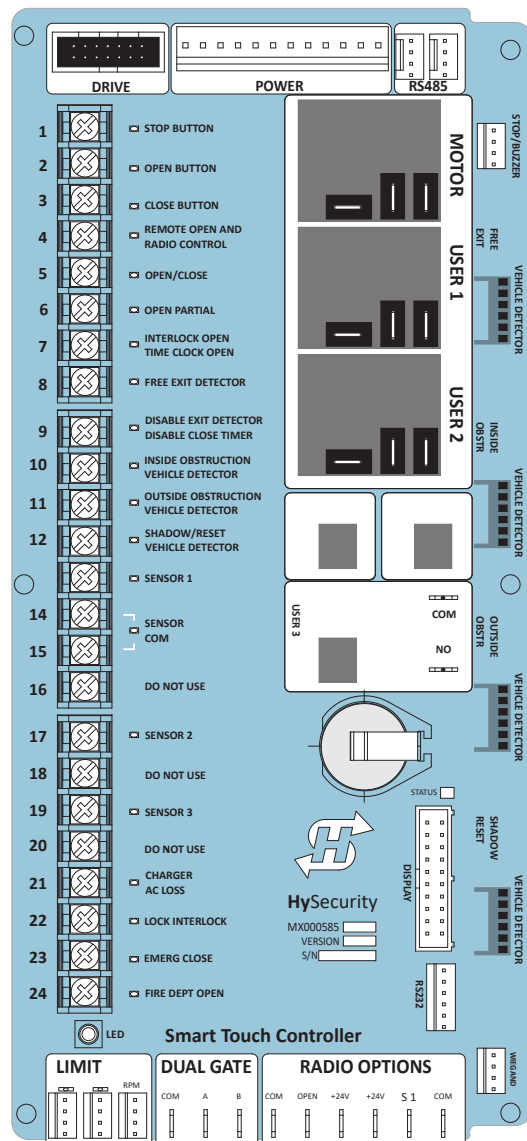
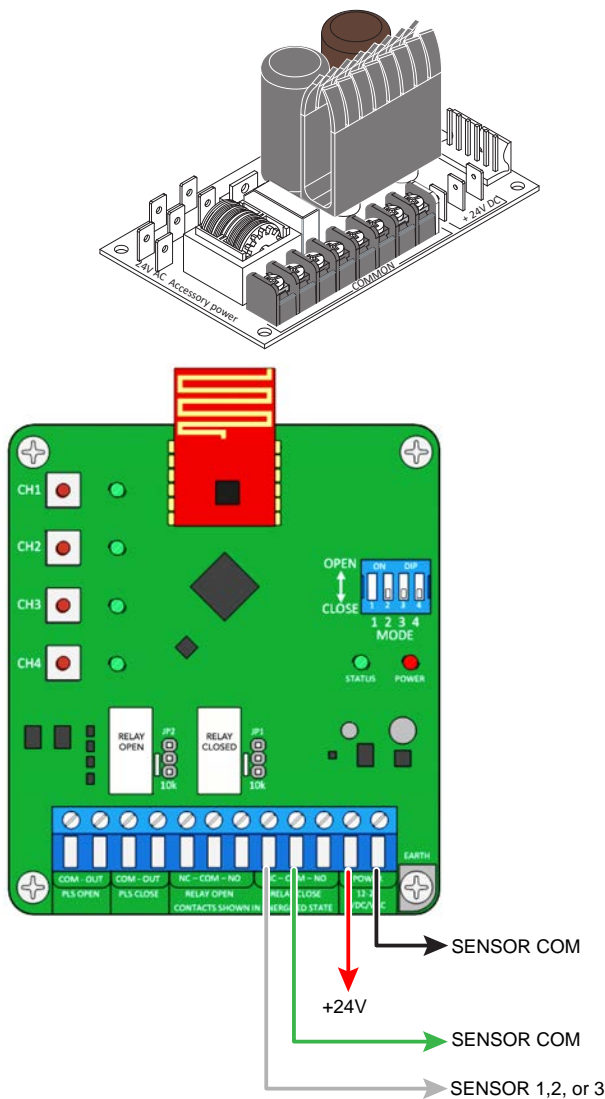

Appendix A - French Translations

FRENCH TRANSLATIONS

The following French translations provided below are found in the Safety Section located at the beginning of the manual.

English	French
<p>IMPORTANT SAFETY INSTRUCTIONS WARNING – To reduce the risk of injury or death:</p>	<p>INSTRUCTIONS DE SÉCURITÉ IMPORTANTES AVERTISSEMENT – Pour réduire les risques de blessures et de mort :</p>
1. READ AND FOLLOW ALL INSTRUCTIONS.	1. LISEZ CETTE NOTICE ET CONFORMEZ-VOUS AUX MISES EN GARDE
2. Never let children operate or play with gate controls. Keep the remote control away from children.	2. Ne laissez jamais les enfants manoeuvrer les commandes de la barrière ou jouer avec celles-ci. Laissez la télécommande hors de la portée des enfants.
3. Always keep people and objects away from the gate. NO ONE SHOULD CROSS THE PATH OF THE MOVING GATE.	3. Tenez toujours à l'écart de la barrière toute personne ou tout objet avoisinant. IL NE FAUT JAMAIS PASSER DANS LA TRAJECTOIRE D'UNE BARRIÈRE EN MOUVEMENT.
4. Test the gate operator monthly. The gate MUST reverse on contact with a rigid object or stop when an object activates the non-contact sensors. After adjusting the force or the limit of travel, retest the gate operator. Failure to adjust and retest the gate operator properly can increase the risk of injury or death.	4. Vérifiez le fonctionnement de l'ouvre-barrière une fois par mois. Le sens de la course DOIT s'inverser lorsque la barrière entre en contact avec un objet dur ou la barrière DOIT s'arrêter lorsqu'un objet active les capteurs sans contact. Vérifiez à nouveau l'ouvre-barrière après tout réglage de la force de déclenchement ou du seuil de fin de course. Un réglage incorrect de l'ouvre-barrière ou l'omission de vérifier à nouveau le fonctionnement de l'ouvre-barrière peut causer des blessures, voire la mort.
5. Use the emergency release only when the gate is not moving.	5. Ne déclenchez le dispositif de désaccouplement d'urgence que lorsque la barrière ne bouge pas.
6. KEEP GATES PROPERLY MAINTAINED. Read the user's manual. Have a qualified service person make repairs to gate hardware.	6. ASSUREZ-VOUS QUE LA BARRIÈRE EST CORRECTEMENT ENTRETENUE. Lisez le manuel de l'utilisateur. Confiez la réparation du matériel de la barrière à un technicien qualifié.
7. The entrance is for vehicles only. Pedestrians must use separate entrance.	7. La voie d'accès est réservée aux véhicules seulement. Les piétons doivent utiliser une voie d'accès différente.
8. SAVE THESE INSTRUCTIONS.	8. CONSERVEZ CES INSTRUCTIONS.

English	French
2.3 Install the gate operator only when:	2.3 N'installez l'ouvre-barrière que si :
a. The operator is appropriate for the construction of the gate and the usage Class of the gate,	a. l'ouvre-barrière est approprié pour la structure et la classe d'utilisation de la barrière;
b. All openings of a horizontal slide gate are guarded or screened from the bottom of the gate to a minimum of 1.83 m (6 ft) above the ground to prevent a 57.2 mm (2-1/4 inch) diameter sphere from passing through the openings anywhere in the gate, and in that portion of the adjacent fence that the gate covers in the open position,	toutes les ouvertures de la barrière coulissante sont protégées ou grillagées du bas de la porte jusqu'à un minimum de 1,83 m (6 pi) du sol si bien qu'une sphère de 57,2 mm (2 1/4 po) de diamètre ne peut passer par une ouverture au niveau de la barrière et de la portion de la clôture adjacente que la barrière couvre en position ouverte;
c. All exposed pinch points are eliminated or guarded, and	c. tous les points de pincement sont éliminés ou protégés;
d. Guarding is supplied for exposed rollers.	d. des protections sont fournies pour les galets exposés.
2.4 The operator is intended for installation only on gates used for vehicles. Pedestrians must be supplied with a separate access opening. The pedestrian access opening shall be designed to promote pedestrian usage. Locate the gate such that persons will not come in contact with the vehicular gate during the entire path of travel of the vehicular gate.	2.4 L'ouvre-barrière est destiné à n'être installé que sur des barrières utilisées pour les véhicules. Il faut fournir une autre voie d'accès aux piétons. La voie d'accès pour les piétons doit être conçue pour favoriser le passage des piétons. Placez la barrière de sorte que personne ne puisse entrer en contact avec la barrière pour les véhicules sur l'ensemble de sa trajectoire
2.5 The gate must be installed in a location so that enough clearance is supplied between the gate and adjacent structures when opening and closing to reduce the risk of entrapment. Swinging gates shall not open into public access areas.	c) Pour réduire les risques de coincement lors de l'ouverture et de la fermeture, la barrière doit être installée dans un endroit où la barrière et les structures avoisinantes sont suffisamment éloignées l'une de l'autre. Les barrières battantes ne doivent pas ouvrir dans une zone d'accès public.

English	French
<p>2.6 The gate must be properly installed and work freely in both directions prior to the installation of the gate operator. Do not over-tighten the operator clutch or pressure relief valve to compensate for a damaged gate.</p>	<p>2.6 La barrière doit être bien installée et fonctionner librement dans les deux directions avant d'entreprendre l'installation de l'ouvre-barrière. Ne serrez pas trop l'embrayage ou la soupape de surpression de l'ouvre-barrière pour compenser une barrière endommagée.</p>
<p>2.7 Controls intended for user activation must be located at least 1.83 m (6 ft) away from any moving part of the gate and where the user is prevented from reaching over, under, around or through the gate to operate the controls. Exception: Emergency access controls only accessible by authorized personnel (e.g. fire, police, EMS) may be placed at any location in the line-of-sight of the gate.</p>	<p>2.7 Les commandes destinées à l'activation par l'utilisateur doivent être situées à au moins 1,83 m (6 pi) des pièces mobiles de la barrière et à un endroit où l'utilisateur ne peut pas atteindre les commandes par le dessus, par le dessous, par les côtés et au travers de la barrière. Exception : Les commandes d'accès d'urgence accessibles au personnel autorisé seulement (p. ex. pompier, policier, SMU) peuvent être placées à tout endroit dans le champ de visibilité de la barrière.</p>
<p>2.8 The Stop and/or Reset button must be located in the line of-sight of the gate. Activation of the reset control shall not cause the operator to start.</p>	<p>2.8 Le bouton d'arrêt, le bouton de réenclenchement ou ces deux boutons doivent être situés dans le champ de visibilité de la barrière. L'activation des commandes de réenclenchement ne doit pas mettre en marche l'ouvrebarrière.</p>
<p>2.9 A minimum of two (2) WARNING SIGNS shall be installed, in the area of the gate. Each placard is to be visible by persons located on the side of the gate on which the placard is installed.</p>	<p>2.9 Au moins deux panneaux de mise en garde doivent être installés dans la zone de la barrière. Chaque étiquette doit être visible des personnes situées de chaque côté de la barrière sur laquelle l'étiquette est installée.</p>
<p>2.10 For gate operators utilizing a non-contact sensor</p>	<p>2.10 Pour les ouvre-barrières qui fonctionnent avec des capteurs</p>
<p>a. See instructions on the placement of non-contact sensors for each Type of application,</p>	<p>a. Voir les instructions sur le positionnement des capteurs sans contact pour chaque type d'utilisation.</p>
<p>b. Care shall be exercised to reduce the risk of nuisance tripping, such as when a vehicle, trips the sensor while the gate is still moving, and</p>	<p>b. Des précautions doivent être prises pour réduire les risques de déclenchement inutile, comme lorsqu'un véhicule déclenche le capteur alors que la barrière est encore en mouvement.</p>
<p>c. One or more non-contact sensors shall be located where the risk of entrapment or obstruction exists, such as the perimeter reachable by a moving gate or barrier.</p>	<p>c. Un capteur sans contact ou plus doit être situé où il existe un risque de coincement ou d'obstruction, comme dans l'espace que peut occuper la barrière lorsqu'elle est en mouvement.</p>
<p>2.11 For a gate operator utilizing a contact sensor</p>	<p>2.11 Pour les ouvre-barrières qui fonctionnent avec des capteurs</p>

English	French
<p>a. One or more contact sensors shall be located where the risk of entrapment or obstruction exists, such as at the leading edge, trailing edge, and postmounted both inside and outside of a vehicular horizontal slide gate.</p>	<p>a. Au moins un capteur de contact doit être situé où il existe un risque de coincement ou d'obstruction, comme sur le bord d'ouverture, sur le bord de fermeture et sur les poteaux montés sur l'intérieur ou l'extérieur d'une barrière coulissante pour véhicules.</p>
<p>b. A hardwired contact sensor shall be located and its wiring arranged so that the communication between the sensor and the gate operator is not subjected to mechanical damage.</p>	<p>b. Un capteur de contact doit être installé et câblé de sorte à éviter que la communication entre le capteur et l'ouvrebarrière soit gênée par des dommages mécaniques.</p>
<p>c. A wireless device such as one that transmits radio frequency (RF) signals to the gate operator for entrapment protection functions shall be located where the transmission of the signals are not obstructed or impeded by building structures, natural landscaping or similar obstruction. A wireless device shall function under the intended end-use conditions.</p>	<p>c. Un dispositif sans fil, comme un appareil qui transmet des signaux de radiofréquence (RF) à l'ouvre-barrière pour prévenir le coincement, doit être situé à un endroit où la transmission des signaux ne sera pas obstruée ou gênée par des structures, des arbres ou d'autres obstacles similaires. Un dispositif sans fil doit fonctionner selon les conditions d'utilisation finale prévues.</p>
<p>d. One or more contact sensors shall be located on the inside and outside leading edge of a swing gate. Additionally, if the bottom edge of a swing gate is greater than 152 mm (6 inches) but less than 406 mm (16 inches) above the ground at any point in its arc of travel, one or more contact sensors shall be located on the bottom edge.</p>	<p>d. Au moins un capteur de contact doit être situé sur les bords d'ouverture intérieur et extérieur d'une barrière battante. De plus, si le dessous d'une barrière battante est situé à plus de 152 mm (6 po) mais à moins de 406 mm (16 po) du sol à l'un des points de sa trajectoire, au moins un capteur de contact doit être situé sur le bord inférieur.</p>

WARRANTY

1. Warranty.

HySecurity Gate, Inc. ("HySecurity") warrants that at the time of sale each HySecurity-branded product that it sells will, in all material respects, conform to its then applicable specification and will be free from defects in material and manufacture.

The following additional durational warranties apply to HySecurity products, depending on whether (1) the product is purchased through an authorized HySecurity distributor and (2) whether a timely and complete product registration is submitted to HySecurity.

It is therefore important that you register your product with HySecurity, online at www.hysecurity.com/warranty, within the 60-day period described below.

1(a) HySecurity Products Purchased Through Authorized Distributors and Properly Registered

For any gate operator product that is purchased from an authorized HySecurity distributor (this excludes product purchased through internet resellers or any distributor not authorized by HySecurity), if the product registration is completed by the Dealer/Installer or End User within 60 days of the date of purchase, the following warranty terms will apply. HySecurity warrants that the product will remain serviceable for the following periods:

- Hydraulic industrial gate operator hydraulics, controls, and mechanical components: Five Years or 500,000 gate cycles (whichever occurs first) after the date of installation,
- Hydraulic wedge operator hydraulics and controls: Five Years or 500,000 cycles (whichever occurs first) after the date of installation. Wedge mechanical components: Two Years after the date of installation,
- Electromechanical pad-mounted Slide and Swing operators: Five Years or 500,000 cycles (whichever occurs first) after the date of installation, except single family residential usage, where the warranty term shall be Seven Years after the date the product was shipped from HySecurity,
- Electromechanical linear actuator Swing operators: Two Years after the date of installation,
- Electromechanical surface mount wedge operator electronics: Two Years or 500,000 gate cycles (whichever occurs first), after the date of installation,
- Electromechanical Barrier Arm Operators: Two years or 1,000,000 gate cycles (whichever occurs first) after the date of installation,

provided that the preceding Five Year warranty period in (a), (b), and (c) will not extend beyond seven years from the date that the product was shipped from HySecurity, and the Two Year warranty period in (b), (d), (e), and (f) will not extend beyond four years from the date that the product was shipped from HySecurity.

The preceding warranty durations do not apply to the products or components described below (g-j), which have a shorter warranty period:

- Hydraulic gate operator drive wheels, including XtremeDrive™ wheels and rack: Two Years from date of installation.
- AC and DC power supplies, chargers, and inverters and HyNet™ Gateway: Two Years from date of installation, except batteries.
- Batteries: One Year from date of shipment from HySecurity.
- Components subject to normal wear including, but not limited to, chains, belts, idler wheels, sprockets and fuses: One Year from date of installation.

1(b) HySecurity Products Not Purchased Through an Authorized Distributor or Not Properly Registered within 60 Days

For any product that is not purchased from an authorized HySecurity distributor or for which the product registration was not completed by the Dealer/Installer/End User within sixty (60) days of the date of purchase, the following warranty will apply: HySecurity warrants that the product will remain serviceable for the following periods, which begin on the date that the product was shipped from HySecurity:

- All gate operators: One Year or 100,000 gate cycles, whichever comes first.
- AC and DC power supplies, chargers, or inverters: One Year.
- HyNet™ Gateway: One Year.
- Hydraulic gate operator drive wheels: One Year.

1(c) Replacement Parts

HySecurity warrants that replacement parts (whether new or reconditioned) will remain serviceable for One Year from the date that the part was shipped from HySecurity or the remaining period of the Gate Operator warranty, whichever is longer.

1(d) Limitations and Exclusions Applicable to Each of the Preceding Warranties.

The preceding warranties shall not apply to equipment that has been (1) installed, maintained, or used improperly or contrary to instructions; (2) subjected to negligence, accident, vandalism, or damaged by severe weather, wind, flood, fire,

terrorism or war; or (3) damaged through improper operation, maintenance, storage or abnormal or extraordinary use or abuse. Any modification made to products will void the warranty unless the modifications are approved in writing by HySecurity in advance of the change (this exclusion does not apply to normal installation of approved accessories and/or protective devices or sensors). It is the responsibility of the Distributor, Dealer/Installer, or End User to ensure that the software version in the product is maintained to the latest revision level.

The preceding warranties do not extend to accessories when those items carry another manufacturer's name plate and they are not a part of the base model. HySecurity disclaims all warranties for such accessory components, which carry only the original warranty, if any, of their original manufacturer. HySecurity hereby assigns its rights under such manufacturer warranties—to the extent that such rights are assignable—to Buyer.

These warranties extend to HySecurity's Distributors, to the Dealer/Installer, and to the first End User of the product following installation. They do not extend to subsequent purchasers.

2. Exclusion of Other Warranties.

The warranties contained in Section 1 are the exclusive warranties given by HySecurity and supersede any prior, contrary or additional representations, whether oral or written. Any prior or extrinsic representations or agreements are discharged or nullified. HYSECURITY HEREBY DISCLAIMS AND EXCLUDES ALL OTHER WARRANTIES—WHETHER EXPRESS, IMPLIED, OR STATUTORY—INCLUDING ANY WARRANTY OF MERCHANTABILITY, ANY WARRANTY OF FITNESS FOR A PARTICULAR PURPOSE, ANY LIABILITY FOR INFRINGEMENT, AND ANY WARRANTIES OTHERWISE ARISING FROM COURSE OF DEALING, COURSE OF PERFORMANCE, OR USAGE OF TRADE.

3. Buyer's Exclusive Remedies for Any Nonconformity.

If a HySecurity product fails to conform to the warranties in Section 1, Buyer must notify and order replacement parts from the Distributor through which the product was purchased within a reasonable time and in no event more than thirty (30) days after the discovery of the nonconformity. HySecurity will investigate and, in the event of a breach, will provide, within a reasonable period of time, one of the following:

- repair or replacement of any nonconforming products or components or
- refund of the price upon return of the nonconforming items. HySecurity reserves the right to supply used or reconditioned material for all warranty claims. HySecurity will not be considered to be in breach of or default under this Warranty because of any failure to perform due to conditions beyond its reasonable control, including any force majeure. This warranty does not cover any incidental expenses, including fines or penalties, temporary security, labor, shipping, travel time or standby time that are incurred for inspection or replacement of any nonconforming items. As a condition of warranty coverage, warranty claims must be submitted in accordance with the procedures described on the HySecurity form, "RMA Procedures."

THE REMEDY SELECTED BY HYSECURITY IN ACCORDANCE WITH THIS PARAGRAPH SHALL BE THE EXCLUSIVE AND SOLE REMEDY OF BUYER FOR ANY BREACH OF WARRANTY.

4. Exclusion of Consequential and Incidental Damages.

HYSECURITY SHALL NOT BE LIABLE FOR ANY INCIDENTAL, SPECIAL, OR CONSEQUENTIAL DAMAGES, WHETHER RESULTING FROM NONDELIVERY OR FROM THE USE, MISUSE, OR INABILITY TO USE THE PRODUCT OR FROM DEFECTS IN THE PRODUCT OR FROM HYSECURITY'S OWN NEGLIGENCE. This exclusion applies regardless of whether such damages are sought for breach of warranty, breach of contract, negligence, or strict liability. This exclusion does not apply to claims for bodily injury or death.

5. Severability.

If any provision of this warranty is found to be invalid or unenforceable, then the remainder shall have full force and effect.

6. Proprietary Rights.

HySecurity retains and reserves all right, title, and interest in the intellectual property rights of its products, including any accompanying proprietary software. No ownership of any intellectual property rights in the products or accompanying software is transferred to Distributor, Dealer/Installer, or End User.

7. Applicable Law.

This warranty will be interpreted, construed, and enforced in all respects in accordance with the laws of the State of Washington, without reference to its choice of law principles. The U.N. Convention on Contracts for the International Sale of Goods will not apply to this warranty.

(This page intentionally blank)

Specifications

HydraSwing™ models

Model	HydraSwing 40	HydraSwing 40 Twin	HydraSwing 40F	HydraSwing 40F Twin	HydraSwing 80F	HydraSwing 150
Single or Twin	Single leaf	Twin (2 leaves)	Single leaf	Twin (2 leaves)	Single leaf	
Duty Cycle	Continuous					
Drive	Hydraulic					
Open/Close Time	15-20 seconds, field adjustable**		10-15 seconds, field adjustable**		15-25 seconds, field adjustable*	20-30 seconds, field adjustable**
Gate Length Max.	up to 24 ft (7.3 m)*	up to 16 ft (5 m) wide each leaf*	up to 16 ft (5 m) wide*	up to 16 ft (5 m) wide each leaf*	up to 30 ft (9 m) wide*	up to 40 ft (12 m) wide*
Gate Weight Max.	4,000 lb (1,814 kg)*	4,000 lb (1,814 kg) / leaf*	4,000 lb (1,814 kg)*	4,000 lb (1,814 kg) / leaf*	8,000 lb (3,629 kg)*	15,000 lb (6,804 kg)*
UPS Battery Backup Cycles	Optional 230V AC Power Supply w/ HyInverter AC™ ***	Optional 230V AC Power Supply w/HyInverter AC™***			Optional 230V AC Power Supply w/ HyInverter AC™ ***	
Temperature Rating	-40° to 158° F (-40° to 70° C)					
Input Voltage	115V or 208-230V 50/60Hz					
Single Phase Voltages	208-230V 50/60Hz, 208/230V 60/50Hz					
Three Phase Voltages	208-230V 50/60Hz or 380/460V 50/60Hz, 208-230V 50/60Hz or 380/460V 60/50Hz	208-230V 50/60Hz or 380/460V 50/60Hz, 208/230 60/50Hz or 380/460 60/50Hz	208-230V 50/60Hz or 380/460V 50/60Hz, 208-230V 50/60Hz or 380/460V 60/50Hz			
Communication	RS-232, RS-485					
User Controls	Smart Touch Controller with 70+ configurable settings. Smart Touch keypad and 32 character, OLED display or a PC using S.T.A.R.T. software.					
Relays	Three configurable user relays: one 30VDC, 3A solid state and two 250VAC, 10A electromechanical. Optional Hy8Relay™ for 8 additional relay outputs.					
Enclosure	Type 3R, 30w x 42h x 12d inch (76w x 107h x 30.5d cm)					
Finish	Zinc plated steel chassis with stainless steel cover				3/4 inch zinc plated steel chassis with black powder coated steel cover	
ETL Listed (UL 325)	Usage Class I, II, III, IV				Usage Class III, IV	
Warranty	5 year w/product registration					

* Gate length/weight specifications are dependent on height, percentage of open area on panel and anticipated wind speed.

** Actual open/close time dependent on gate weight/length, percentage of open area on panel and anticipated wind speed.

*** The operator's normal duty cycle and the actual number of gate cycles available from battery depends upon gate resistance to travel, cycle length, battery size, state of charge and health, ambient temperature, accessory power draw and frequency of gate cycles during power outage.